

Internet Engineering Task Force
Internet-Draft
Intended status: Standards Track
Expires: May 21, 2008

D. Harkins, Ed.
Aruba Networks
November 18, 2007

SIV Authenticated Encryption using AES
draft-dharkins-siv-aes-01

Status of this Memo

By submitting this Internet-Draft, each author represents that any applicable patent or other IPR claims of which he or she is aware have been or will be disclosed, and any of which he or she becomes aware will be disclosed, in accordance with [Section 6 of BCP 79](#).

Internet-Drafts are working documents of the Internet Engineering Task Force (IETF), its areas, and its working groups. Note that other groups may also distribute working documents as Internet-Drafts.

Internet-Drafts are draft documents valid for a maximum of six months and may be updated, replaced, or obsoleted by other documents at any time. It is inappropriate to use Internet-Drafts as reference material or to cite them other than as "work in progress."

The list of current Internet-Drafts can be accessed at <http://www.ietf.org/ietf/lid-abstracts.txt>.

The list of Internet-Draft Shadow Directories can be accessed at <http://www.ietf.org/shadow.html>.

This Internet-Draft will expire on May 21, 2008.

Copyright Notice

Copyright (C) The IETF Trust (2007).

Abstract

This memo describes SIV, a block cipher mode of operation. SIV takes a key, a plaintext, and multiple variable-length octet strings which will be authenticated but not encrypted. It produces a ciphertext having the same length as the plaintext and a synthetic initialization vector. Depending on how it is used, SIV achieves either the goal of deterministic authenticated-encryption or the goal of nonce-based, misuse-resistant authenticated-encryption.

Internet-Draft

SIV-AES

November 2007

Table of Contents

1.	Introduction	3
1.1.	Background	3
1.2.	Definitions	4
1.3.	Motivation	4
1.3.1.	Key Wrapping	4
1.3.2.	Resistance to Nonce Misuse/Reuse	4
1.3.3.	Key Derivation	5
1.3.4.	Robustness versus Performance	5
2.	Specification of SIV	6
2.1.	Notation	6
2.2.	Overview	7
2.3.	Doubling	7
2.4.	S2V	7
2.5.	CTR	10
2.6.	SIV Encrypt	10
2.7.	SIV Decrypt	12
3.	Nonce-based Authenticated Encryption with SIV	14
4.	Deterministic Authenticated Encryption with SIV	15
5.	Optimizations	15
6.	IANA Considerations	15
6.1.	AEAD_SIV_CMAC_256	16
6.2.	AEAD_SIV_CMAC_384	16
6.3.	AEAD_SIV_CMAC_512	17
7.	Security Considerations	17
8.	Acknowledgments	18
9.	References	18
9.1.	Normative References	18
9.2.	Informative References	19
Appendix A.	Test Vectors	20
A.1.	Deterministic Authenticated Encryption Example	20
A.2.	Nonce-based Authenticated Encryption Example	22
	Author's Address	24
	Intellectual Property and Copyright Statements	25

Internet-Draft

SIV-AES

November 2007

1. Introduction

1.1. Background

Various attacks have been described (e.g. [[BADESP](#)]) when data is merely privacy-protected and not additionally authenticated or integrity protected. Therefore combined modes of encryption and authentication have been developed ([[AEAD](#)], [[CCM](#)], [[GCM](#)], [[JUTLA](#)], [[OCB](#)]). These provide conventional authenticated-encryption when used with a nonce ("a number used once") and typically accept additional inputs that are authenticated but not encrypted, hereinafter referred to as "associated data" or AD.

A deterministic, nonce-less, form of authenticated-encryption has been used to protect the transportation of cryptographic keys (e.g. [[X9F1](#)], [[RFC3217](#)], [[RFC3394](#)]). This is generally referred to as "Key Wrapping".

This memo describes a new block cipher mode, SIV, that provides both nonce-based authenticated encryption as well as deterministic, nonce-less key wrapping. It contains a PRF construction called S2V and an encryption/decryption construction, called CTR. SIV was specified by Phillip Rogaway and Thomas Shrimpton in [[DAE](#)]. The underlying block cipher used herein for both S2V and CTR is AES with key lengths of 128 bits, 192 bits, or 256 bits. S2V uses AES in CMAC ([[CMAC](#)]) mode, CTR uses AES in counter ([[MODES](#)]) mode.

Associated data is data input to an authenticated-encryption mode that will be authenticated but not encrypted. [[AEAD](#)] says that associated data can include "addresses, ports, sequence numbers, protocol version numbers, and other fields that indicate how the plaintext or ciphertext should be handled, forwarded, or processed." These are multiple, distinct inputs and may not be contiguous. Other authenticated-encryption cipher modes allow only a single associated data input. Such a limitation may require implementation of a scatter/gather form of data marshalling to combine the multiple

components of the associated data into a single input or may require a pre-processing step where the associated data inputs are concatenated together. SIV accepts multiple variable-length octet strings (hereinafter referred to as a "vector of strings") as associated data inputs. This obviates the need for data marshalling or pre-processing of associated data to package it into a single input.

By allowing associated data to consist of a vector of strings SIV also obviates the requirement to encode the length of component fields of the associated data when those fields have variable length.

[1.2.](#) Definitions

The key words "MUST", "MUST NOT", "REQUIRED", "SHALL", "SHALL NOT", "SHOULD", "SHOULD NOT", "RECOMMENDED", "MAY", and "OPTIONAL" in this document are to be interpreted as described in [RFC 2119](#) [[RFC2119](#)].

[1.3.](#) Motivation

[1.3.1.](#) Key Wrapping

A key distribution protocol must protect keys it is distributing. This has not always been done right. For example RADIUS [[RFC2548](#)] uses MPPE to encrypt a key prior to transmission from server to client. It provides no integrity checking of the encrypted key. [[RADKEY](#)] specifies the use of [[RFC3394](#)] to wrap a key in a RADIUS [[RFC2865](#)] request but because of the inability to pass associated data an HMAC [[RFC2104](#)] is necessary to provide authentication of the entire request.

SIV can be used as a drop-in replacement for any specification that uses [[RFC3394](#)] or [[RFC3217](#)], including the aforementioned use. It is a more general purpose solution as it allows for associated data to be specified.

[1.3.2.](#) Resistance to Nonce Misuse/Reuse

The nonce-based authenticated encryption schemes described above are susceptible to reuse and/or misuse of the nonce. Depending on the specific scheme there are subtle and critical requirements placed on

the nonce (see [[SP800-38D](#)]). [[GCM](#)] states that it provides "excellent security" if its nonce is guaranteed to be distinct but provides "no security" otherwise. Confidentiality guarantees are voided if a counter in [[CCM](#)] is reused. In many cases guaranteeing no reuse of a nonce/counter/IV is not a problem but in others it will be.

For example, many applications obtain access to cryptographic functions via an application program interface to a cryptographic library. These libraries are typically not stateful and any nonce, initialization vector, or counter required by the cipher mode is passed to the cryptographic library by the application. Putting the construction of a security-critical datum outside the control of the encryption engine places an onerous burden on the application writer who may not provide the necessary cryptographic hygiene. Perhaps his random number generator is not too good or maybe an application fault causes a counter to be reset. The fragility of the cipher mode may result in its inadvertent misuse. Also, if one's environment is (knowingly or unknowingly) a virtual machine it may be possible to

roll back a virtual state machine and cause nonce reuse thereby gutting the security of the authenticated encryption scheme (see [[VIRT](#)]).

If the nonce is random a requirement that it never repeat will limit the amount of data that can be safely protected with a single key to a one block. More sensibly a random nonce is required to "almost always" be non-repeating but that will drastically limit the amount of data that can be safely protected.

SIV provides a level of resistance to nonce reuse and misuse. If the nonce is never reused then the usual notion of nonce-based security of an authenticated encryption mode is achieved. If, however, the nonce is reused authenticity is retained and confidentiality is only compromised to the extent that an attacker can determine that the same plaintext (and same associated data) was protected with the same nonce and key. See Security Considerations ([Section 7](#)).

[1.3.3](#). Key Derivation

A PRF is frequently used as a key derivation function (e.g. [[WLAN](#)]) by passing it a key and a single string. Typically this single

string is the concatenation of a series of smaller strings--for example, a label and some context to bind into the derived string.

These are usually multiple strings but are mapped to a single string because of the way PRFs are typically defined--two inputs: a key and data. Such a crude mapping is inefficient because additional data must be included--the length of variable-length inputs must be encoded separately--and, depending on the PRF, memory allocation and copying may be needed. Also, if only one or two of the inputs changed when deriving a new key it may still be necessary to process all of the other constants that preceded it every time the PRF is invoked.

When a PRF is used in this manner its input is a vector of strings and not a single string and the PRF should handle the data as such. The S2V ("string to vector") PRF construction accepts a vector of inputs and provides a more natural mapping of input that does not require additional lengths encodings and obviates the memory and processing overhead to marshall inputs and their encoded lengths into a single string. Constant inputs to the PRF need only be computed once.

[1.3.4.](#) Robustness versus Performance

SIV can not perform at the same high throughput rates that other authenticated encryption schemes can (e.g. [\[GCM\]](#) or [\[OCB\]](#)) due to the requirement for two passes of the data but for situations where

performance is not a limiting factor-- e.g. control plane applications-- it can provide a robust alternative, especially when considering its resistance to nonce re-use.

[2.](#) Specification of SIV

[2.1.](#) Notation

SIV and S2V use the following notation:

len(A)

returns the number of bits in A.

pad(X)

indicates padding of string X , $\text{len}(X) < 128$, out to 128 bits by the concatenation of a single bit of 1 followed by as many 0 bits as are necessary.

`leftmost(A,n)`
the n most significant bits of A .

`rightmost(A,n)`
the n least significant bits of A .

`chop(A, B)`
is reduction of string A , being at least B bits in length, to B bits.

`A || B`
means concatenation of string A with string B .

`A xor B`
is the exclusive OR operation on two equal length strings, A and B .

`A xorend B`
where $\text{len}(A) \geq \text{len}(B)$, means xoring a string B onto the end of string A -- i.e. `leftmost(A, len(A)-len(B)) || (rightmost(A, len(B)) xor B)`

`dbl(S)`
is the multiplication of S and $0\dots010$ in a finite field represented using the primitive polynomial $x^{128} + x^7 + x^2 + x + 1$. See Doubling ([Section 2.3](#))

`ab`
indicates a string that is " b " bits each having the value " a ".

`<zero>`
indicates a string that is 128 zero bits.

`<one>`
indicates a string that is 127 zero bits concatenated with a

single one bit, that is $0^{127} || 1^1$.

A/B

indicates the greatest integer less than or equal to the real-valued quotient of A and B.

E(K,X)

indicates AES encryption of string X using key K

[2.2.](#) Overview

SIV-AES uses AES in counter mode (CTR) and in CMAC mode (S2V). SIV-AES takes either a 256, 384, or 512 bit key (which is broken up into two equal-sized keys, one for CTR and the other for S2V), a variable length plaintext, and multiple variable length strings representing associated data. It's output is a ciphertext which comprises a synthetic initialization vector concatenated with the encrypted plaintext.

[2.3.](#) Doubling

The doubling operation on an input string is performed using a left-shift of the input followed by a conditional xor operation on the result with the constant:

00000000 00000000 00000000 00000087

The condition under which the xor operation is performed is when the bit being shifted off is one.

Note that this is the same operation used to generate sub-keys for CMAC-AES

[2.4.](#) S2V

The S2V operation consists of the doubling and xoring of the outputs of a pseudo-random function, CMAC, operating over individual strings in the input vector. It is bootstrapped by performing CMAC on a 128-bit string of zeros. If the length of the final string in the vector is greater than or equal to 128 bits the doubled and xored output is

xored onto the end of the final input string. That result is input

to a final CMAC operation to produce the output Z. If the length of the final string is less than 128 bits the doubled and xored output is doubled once more and it is xored with the final string padded using the padding function pad(X). That result is input to a final CMAC operation to produce the output Z.

S2V with key k on a vector of n inputs X1, X2, ..., Xn-1, Xn, and len(Xn) >= 128:

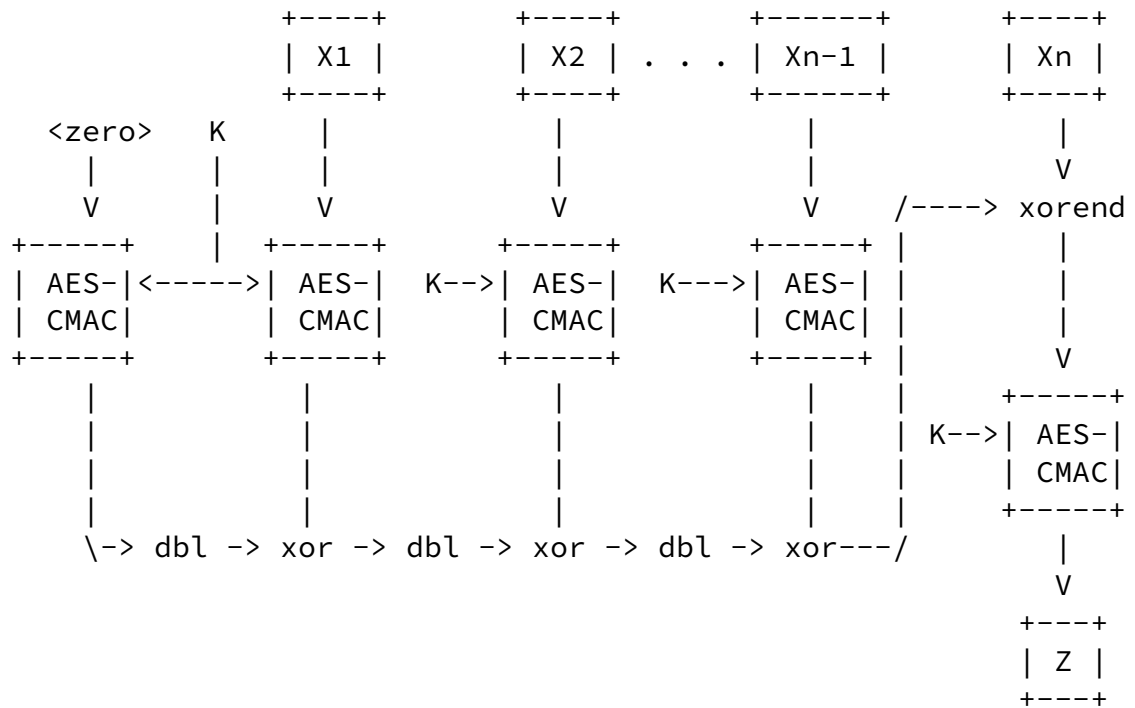

where 'dbl' is the double operation.

Figure 2

S2V with key k on a vector of n inputs $X_1, X_2, \dots, X_{n-1}, X_n$, and $\text{len}(X_n) < 128$:

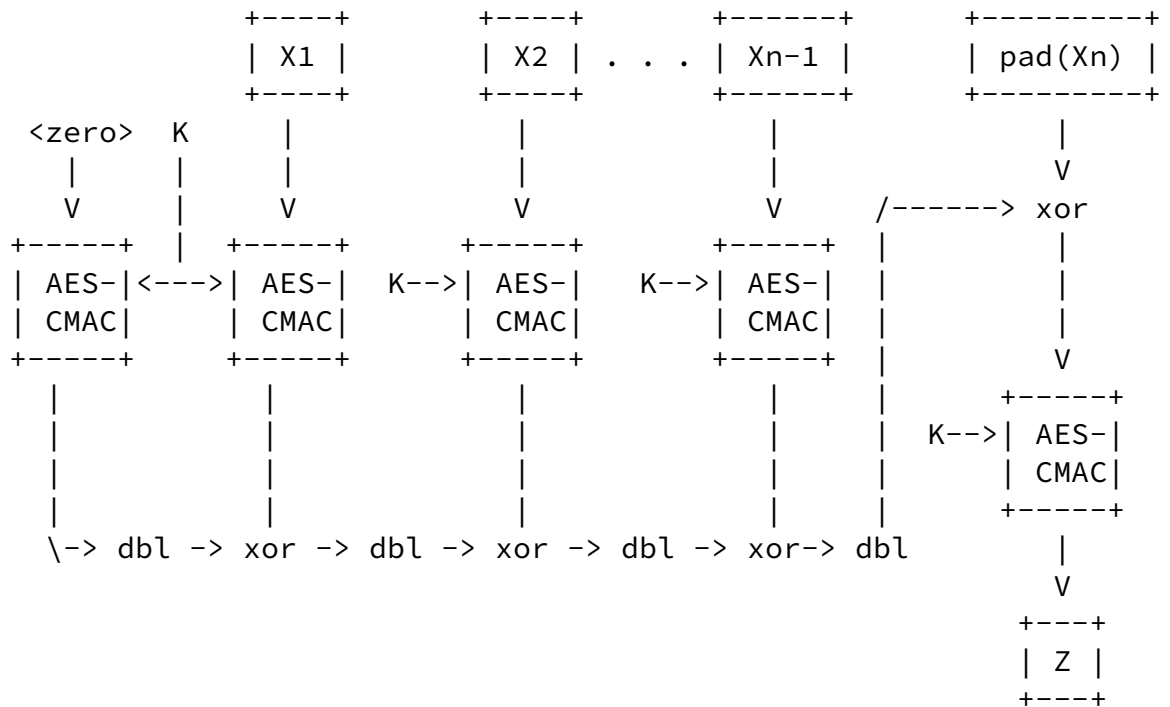

where 'dbl' is the double operation.

Figure 3

Algorithmically S2V can be described as:

```

S2V(K, X1, ..., Xn) {
  if n = 0 then
    return AES-CMAC(K, <one>)
  fi
  S = AES-CMAC(K, <zero>)
  for i = 1 to n-1 do
    S = dbl(S) xor AES-CMAC(K, Xi)
  done
  if len(Xn) >= 128 then
    T = Xn xorend S
  else
    T = dbl(S) xor pad(Xn)
  fi
  return Z = AES-CMAC(K, T)
}
    
```

[2.5.](#) CTR

CTR is a counter mode of AES. It takes as input a plaintext P of arbitrary length, a key K of length 128, 192 or 256 bits, and a counter X that is 128 bits in length, and outputs Z which represents a concatenation of a synthetic initialization vector V , and the ciphertext, C , which is the same length as the plaintext.

The ciphertext is produced by xoring the plaintext with the first $\text{len}(P)$ bits of the following string:

$$E(K, X) \parallel E(K, X+1) \parallel E(K, X+2) \parallel \dots$$

Before beginning counter mode the 32nd and 64th bits (where the rightmost bit is the 0th bit) of the counter are cleared. This enables implementations which support native 32 bit (64 bit) addition to increment the counter modulus 2^{32} (2^{64}). More formally, for 32 bit addition the counter is incremented as:

$$\text{SALT} = \text{leftmost}(X, 96)$$

$$n = \text{rightmost}(X, 32)$$

$$X+i = \text{SALT} \parallel (n + i \bmod 2^{32}).$$

For 64 bit addition the counter is incremented as:

$$\text{SALT} = \text{leftmost}(X, 64)$$

$$n = \text{rightmost}(X, 64)$$

$$X+i = \text{SALT} \parallel (n + i \bmod 2^{64}).$$

Performing 32 bit or 64 bit addition on the counter will limit the amount of plaintext that can be safely protected by SIV-AES to $2^{39} - 128$ bits or $2^{71} - 128$ bits, respectively.

[2.6.](#) SIV Encrypt

SIV-encrypt takes as input a key K of length 256, 384 or 512 bits, plaintext of arbitrary length, and a vector of associated data where the number of components in the vector is not greater than 126 (see [Section 7](#)). It produces output, Z , which is the concatenation a 128 bit synthetic initialization vector and ciphertext whose length is equal to the length of the plaintext.

The key is split into equal halves, $K_1 = \text{leftmost}(K, \text{len}(K)/2)$ and $K_2 = \text{rightmost}(K, \text{len}(K)/2)$. K_1 is used for S2V and K_2 is used for CTR.

In the encryption mode the associated data and plaintext represent the vector of inputs to S2V, with the plaintext being the last string in the vector. The output of S2V is a synthetic IV which represents the initial counter to CTR.

The encryption construction of SIV is as follows:

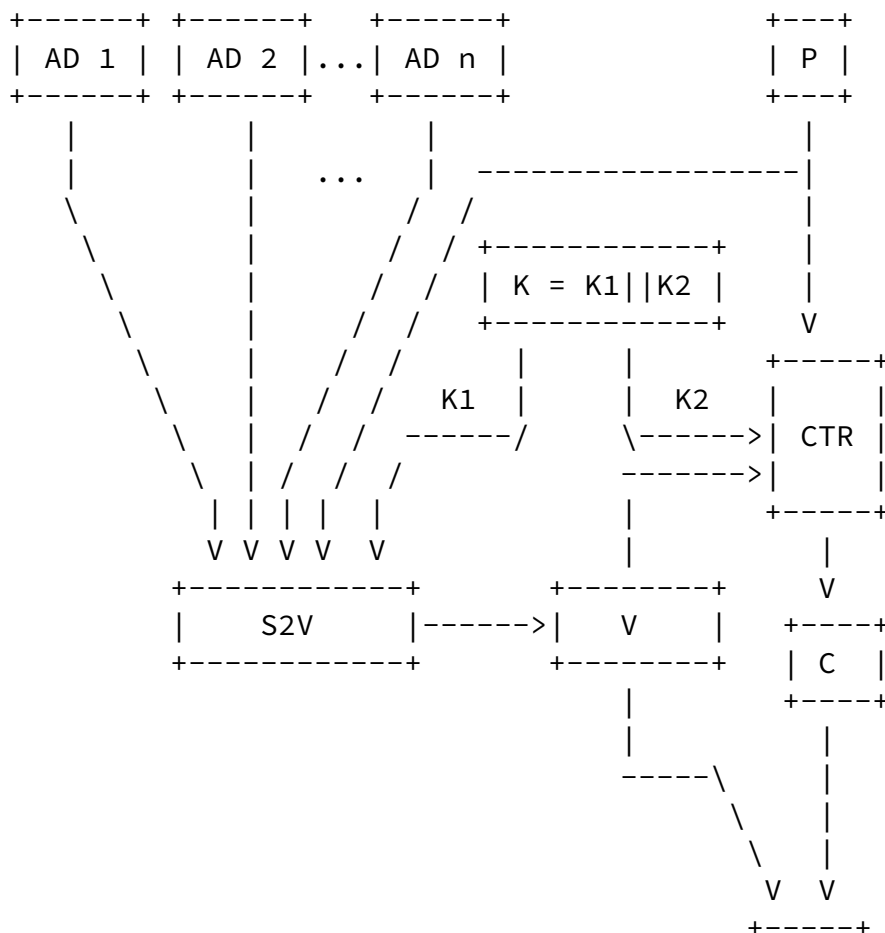

| Z |
+-----+

where the plaintext is P, the associated data is AD1 through ADn, V is the synthetic IV, the ciphertext is C, and Z is the output.

Figure 8

Algorithmically SIV Encrypt can be described as:

```
SIV-ENCRYPT(K, P, AD1, ..., ADn) {
  K1 = leftmost(K, len(K)/2)
  K2 = rightmost(K, len(K)/2)
  V = S2V(K1, AD1, ..., ADn, P)
  Q = V xor (1^64 || 0^1 || 1^31 || 0^1 || 1^31)
  m = (len(P) + 127)/128

  for i = 0 to m-1 do
    Xi = AES(K2, Q+i)
  done
  X = chop(X0 || ... || Xm-1, len(P))
  C = P xor X

  return V || C
}
```

where the key length used by AES in CTR and S2V is $\text{len}(K)/2$ and will each be either 128 bits, 192 bits, or 256 bits.

The 32nd and 64th bit (where the rightmost bit is the 0th) of the counter are zeroed out just prior to being used by CTR for optimization purposes, see [Section 5](#).

2.7. SIV Decrypt

SIV-decrypt takes as input a key K of length 256, 384 or 512 bits, Z which represents a synthetic initialization vector V concatenated with a ciphertext C , and a vector of associated data where the number of components in the vector is not greater than 126 (see [Section 7](#)). It produces either the original plaintext or the special symbol FAIL.

The key is split as specified in [Section 2.6](#)

The synthetic initialization vector acts as the initial counter to CTR to decrypt the ciphertext. The associated data and the output of CTR represents a vector of strings that is passed to S2V, with the CTR output being the last string in the vector. The output of S2V is then compared against the synthetic IV that accompanied the original ciphertext. If they match the output from CTR is returned as the decrypted and authenticated plaintext otherwise the special symbol FAIL is returned.

The decryption construction of SIV is as follows:

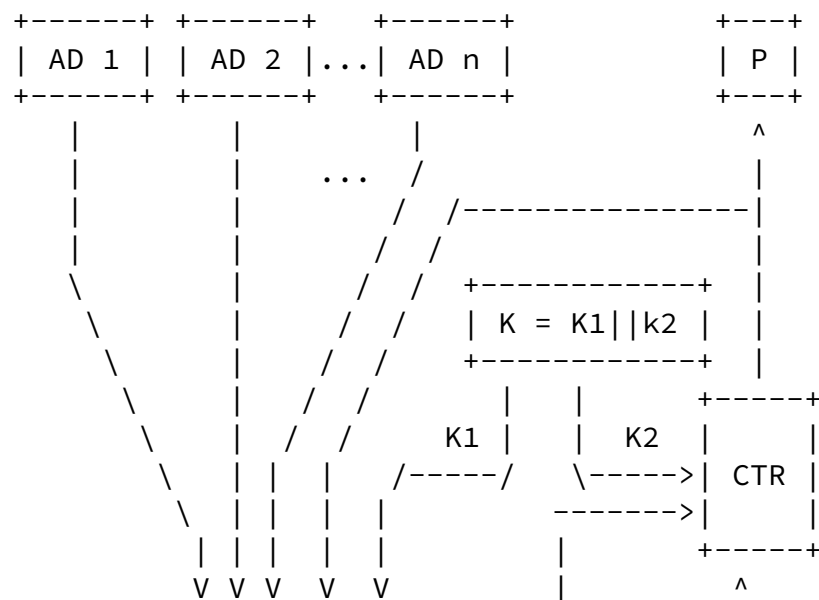

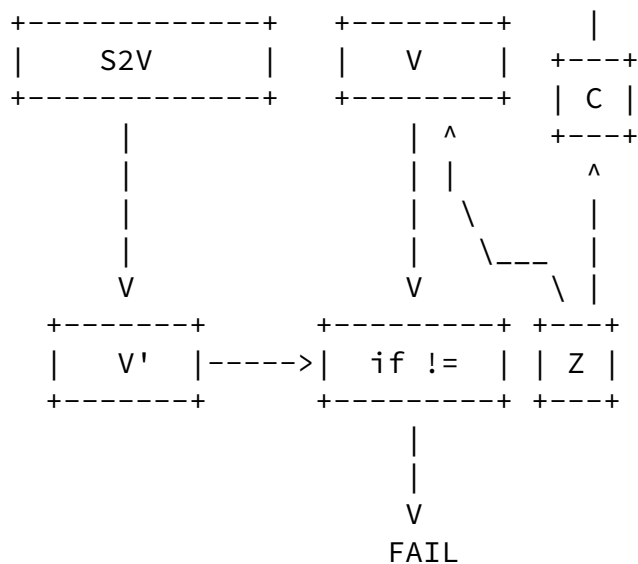

Figure 10

Algorithmically SIV-Decrypt can be described as:

```

SIV-DECRYPT(K, Z, AD1, ..., ADn) {
  V = leftmost(Z, 128)
  C = rightmost(Z, len(Z)-128)
  K1 = leftmost(K, len(K)/2)
  K2 = rightmost(K, len(K)/2)
  Q = V xor (1^64 || 0^1 || 1^31 || 0^1 || 1^31)

  m = (len(C) + 127)/128
  for i = 0 to m-1 do
  
```

```

    Xi = AES(K2, Q+i)
done
X = chop(X0 || ... || Xm-1, len(C))
P = C xor X
T = S2V(K1, AD1, ..., ADn, P)

if T = V then
    return P
else
    return FAIL
fi
}

```

where the key length used by AES in CTR and S2V is $\text{len}(K)/2$ and will each be either 128 bits, 192 bits, or 256 bits.

The 32nd and 64th bit (where the rightmost bit is the 0th) of the counter are zeroed out just prior to being used in CTR mode for optimization purposes, see [Section 5](#).

[3](#). Nonce-based Authenticated Encryption with SIV

SIV performs nonce-based authenticated encryption when a component of the associated data is a nonce. For purposes of interoperability the final component-- i.e. the string immediately preceding the plaintext in the vector input to S2V-- is used for the nonce. Other associated data are optional. It is up to the specific application of SIV to specify how the rest of the associated data are input.

If the nonce is random it SHOULD be at least 128 bits in length and be harvested from a pool having at least 128 bits of entropy. A non-random source MAY also be used, for instance a time stamp, or a counter. The definition of a nonce precludes reuse but SIV is resistant to nonce reuse. See [Section 1.3.2](#) for a discussion on the security implications of nonce reuse.

It MAY be necessary to transport this nonce with the output generated by S2V.

4. Deterministic Authenticated Encryption with SIV

When the plaintext to encrypt and authenticate contains data that is unpredictable to an adversary-- for example, a secret key-- SIV can be used in a deterministic mode to perform "key wrapping". Because SIV allows for associated data and imposes no unnatural size restrictions on the data it is protecting it is a more useful and general purpose solution than [RFC3394]. Protocols which use SIV for deterministic authenticated encryption (i.e. for more than just wrapping of keys) MAY define associated data inputs to SIV. It is not necessary to add a nonce component to the AD in this case.

5. Optimizations

Implementations which cannot or do not wish to support addition modulo 2^{128} can take advantage of the fact that the 32nd and 64th bits (where the rightmost bit is the 0th bit) in the counter are cleared before being used by CTR. This allows implementations which natively support 32 bit or 64 bit addition to increment the counter naturally. Of course in this case the amount of plaintext that can be safely protected by SIV is reduced by a commensurate amount-- addition modulo 2^{32} limits plaintext to $(2^{32} - 1)$ blocks, addition modulo 2^{64} limits plaintext to $(2^{64} - 1)$ blocks.

It is possible to optimize an implementation of SIV when it is being used as a key derivation function (KDF), for example in [WLAN]. This is because SIV operates on a vector of distinct strings and typically the data passed to a KDF contains constant strings. Depending on the location of the variant component of the input the CMAC'd output of intermediate and invariant components can be computed once and xor'd with the running sum or an intermediate value of the doubled and xor'd output up to the variant component can be computed once and cached.

6. IANA Considerations

[AEAD] defines a uniform interface to cipher modes which provide nonce-based authenticated encryption with associated data (AEAD). It does this via a registry of AEAD algorithms.

The Internet Assigned Numbers Authority (IANA) will assign three entries from the AEAD Registry for SIV-CMAC-256, SIV-CMAC-384, SIV-

CMAC-512 based upon the following AEAD algorithm definitions. [AEAD] defines operations in octets, not bits. Limits in this section will therefore be specified in octets. The security analysis for each of these algorithms is in [DAE].

Unfortunately [AEAD] restricts AD input to a single component and limits the benefit SIV offers for dealing in a natural fashion with AD consisting of multiple distinct components. Therefore when it is required to access SIV through the interface defined in [AEAD] it is necessary to marshall multiple AD inputs into a single string (see [Section 1.1](#)) prior to invoking SIV. Note that this requirement is not unique to SIV. All cipher modes using [AEAD] MUST similarly marshall multiple AD inputs into a single string and any technique used for any other AEAD mode (e.g. a scatter/gather technique) can be used with SIV.

[6.1.](#) AEAD_SIV_CMAC_256

The SIV-CMAC-256 AEAD algorithm works as specified in [Section 2.6](#) and [Section 2.7](#) using CMAC-AES in S2V. The input and output lengths for SIV-CMAC-256 as defined by [AEAD] are:

K_LEN is 32 octets.

P_MAX is unlimited.

A_MAX is unlimited.

N_MIN is 1 octet.

N_MAX is unlimited.

C_MAX is unlimited.

The security implications of nonce re-use and/or mis-use are described in [Section 1.3.2](#).

[6.2.](#) AEAD_SIV_CMAC_384

The SIV-CMAC-384 AEAD algorithm works as specified in [Section 2.6](#) and [Section 2.7](#) using CMAC-AES in S2V. The input and output lengths for SIV-CMAC-384 as defined by [AEAD] are:

K_LEN is 48 octets.

Internet-Draft

SIV-AES

November 2007

P_MAX is unlimited.

A_MAX is unlimited.

N_MIN is 1 octet.

N_MAX is unlimited.

C_MAX is unlimited.

The security implications of nonce re-use and/or mis-use are described in [Section 1.3.2](#).

[6.3](#). AEAD_SIV_CMAC_512

The SIV-CMAC-512 AEAD algorithm works as specified in [Section 2.6](#) and [Section 2.7](#) using CMAC-AES in S2V. The input and output lengths for SIV-CMAC-512 as defined by [\[AEAD\]](#) are:

K_LEN is 64 octets.

P_MAX is unlimited.

A_MAX is unlimited.

N_MIN is 1 octet.

N_MAX is unlimited.

C_MAX is unlimited.

The security implications of nonce re-use and/or mis-use are described in [Section 1.3.2](#).

[7](#). Security Considerations

SIV provides privacy in the sense that the output of SIV-Encrypt is indistinguishable from a random string of bits. It provides authenticity in the sense that an attacker is unable to construct

a string of bits that will return other than FAIL when input to SIV-Decrypt. A proof of the security of SIV with an "all in one" notion of security for an authenticated encryption scheme is provided in [\[DAE\]](#).

SIV provides deterministic "key wrapping" when the plaintext contains data that is unpredictable to an adversary (for instance, a cryptographic key). Even when this key is made available to an

attacker the output of SIV-Encrypt is indistinguishable from random bits. Similarly, even when this key is made available to an attacker she is unable to construct a string of bits that when input to SIV-Decrypt will anything other than FAIL.

When the nonce used in the nonce-based authenticated encryption mode of SIV-AES is treated with the care afforded a nonce or counter in other conventional nonce-based authenticated encryption schemes-- i.e. guarantee that it will never be used with the same key for two distinct invocations-- then SIV achieves the level of security described above. If, however, the nonce is reused SIV continues to provide the level of authenticity described above but with a slightly reduced amount of privacy (see [Section 1.3.2](#)).

If S2V is used as a key derivation function the secret input MUST be generated uniformly at random. S2V is a pseudo-random function and is not suitable for use as a random oracle as defined in [\[RANDORCL\]](#).

The security bound set by the proof of security of S2V in [\[DAE\]](#) depends on the number of vector-based queries made by an adversary and the total number of all components in those queries. The security is only proven when the number of components in each query is limited to $n-1$, where n is the blocksize of the underlying pseudo-random function. The underlying pseudo-random function used here is based on AES whose blocksize is 128 bits. Therefore S2V must not be passed more than 127 components. Since SIV includes the plaintext as a component to S2V that limits the number of components of associated data that can be safely passed to SIV to 126.

[8](#). Acknowledgments

Thanks to Phil Rogaway for patiently answering numerous questions on

SIV and S2V and for useful critiques of earlier versions of this paper. Thanks also to David McGrew for numerous helpful comments and suggestions for improving this paper. Thanks to Jouni Malinen for producing another independent implementation of S2V (using CMAC as the pseudo-random function) and thereby confirming the correctness of the test vectors.

[9.](#) References

[9.1.](#) Normative References

- [CMAC] Dworkin, M., "Recommendation for Block Cipher Modes of Operation: The CMAC Mode for Authentication", NIST Special Publication 800-38B.

Harkins

Expires May 21, 2008

[Page 18]

Internet-Draft

SIV-AES

November 2007

- [DAE] Rogaway, P. and T. Shrimpton, "Deterministic Authenticated Encryption, A Provable-Security Treatment of the Key-Wrap Problem", September 2006.
- [GCM] McGrew, D. and J. Viega, "The Galois/Counter Mode of Operation (GCM)".
- [MODES] Dworkin, M., "Recommendation for Block Cipher Modes of Operation: Methods and Techniques", NIST Special Publication 800-38A, 2001 edition.
- [RFC2119] Bradner, S., "Key words for use in RFCs to Indicate Requirement Levels", [BCP 14](#), [RFC 2119](#), March 1997.

[9.2.](#) Informative References

- [AEAD] McGrew, D., "An Interface and Algorithms for Authenticated Encryption", Internet-Draft: [draft-mcgrew-auth-enc-02.txt](#) (a work in progress), February 2007.
- [BADESP] Bellare, S., "Problem Areas for the IP Security Protocols", July 1996.
- [CCM] Whiting, D., Housley, R., and N. Ferguson, "Counter With CBC-MAC (CCM)", June 2002.

- [JUTLA] Jutla, C., "Encryption Modes With Almost Free Message Integrity", Proceedings of the International Conference on the Theory and Application of Cryptographic Techniques: Advances in Cryptography.
- [OCB] Korvetz, T. and P. Rogaway, "The OCB Authenticated Encryption Algorithm",
Internet-Draft: [draft-krovetz-ocb-00.txt](#) (a work in progress).
- [RADKEY] Zorn, G., "RADIUS Attributes for the Delivery of Keying Material",
Internet-Draft: [draft-zorn-radius-keywrap-13.txt](#) (a work in progress).
- [RANDORCL] Bellare, M. and P. Rogaway, "Random Oracles are Practicle: A Paradigm for Designing Efficient Protocols", Proceeding of the First ACM Conference on Computer and COmmunications Security ACM, November 1993.
- [RFC2104] Krawczyk, H., Bellare, M., and R. Canetti, "HMAC: Keyed-

- Hashing for Message Authentication", February 1997,
<<http://www.ietf.org/rfc/rfc2104.txt>>.
- [RFC2548] Zorn, G., "Microsoft Vendor-specific RADIUS Attributes",
March 1999, <<http://www.ietf.org/rfc/rfc2548.txt>>.
- [RFC2865] Rigney, C., Williams, S., Rubens, A., and W. Simpson,
"Remote Authentication Dial In User Service", June 2000,
<<http://www.ietf.org/rfc/rfc2865.txt>>.
- [RFC3217] Housley, R., "Triple-DES and RC2 Key Wrapping",
December 2001, <<http://www.ietf.org/rfc/rfc3217.txt>>.
- [RFC3394] Housley, R., "AES Key Wrap", February 2005,
<<http://www.ietf.org/rfc/rfc3394.txt>>.
- [SP800-38D] Dworkin, M., "Recommendations for Block Cipher Modes of
Operation: Galois Counter Mode (GCM) and GMAC", NIST

Special Publication 800-38D, June 2007.

- [VIRT] Garfinkel, T. and M. Rosenblum, "When Virtual is Harder than Real: Security Challenges in Virtual Machine Based Computing Environments".
- [WLAN] "Draft Standard for IEEE802.11: Wireless LAN Medium Access Control (MAC) and Physical Layer (PHY) Specification", 2007.
- [X9F1] Dworkin, M., "Wrapping of Keys and Associated Data", Request for review of key wrap algorithms. Cryptology ePrint report 2004/340, 2004. Contents are excerpts from a draft standard of the Accredited Standards Committee, X9, entitled ANS X9.102.

[Appendix A](#). Test Vectors

The following test vectors are for the mode defined in [Section 6.1](#).

[A.1](#). Deterministic Authenticated Encryption Example

Input:

Key:

fffefdfc fbfaf9f8 f7f6f5f4 f3f2f1f0
f0f1f2f3 f4f5f6f7 f8f9fafb fcfdfeff

Harkins

Expires May 21, 2008

[Page 20]

Internet-Draft

SIV-AES

November 2007

AD:

10111213 14151617 18191a1b 1c1d1e1f
20212223 24252627

Plaintext:

11223344 55667788 99aabbcc ddee

S2V-CMAC-AES

CMAC(zero):

0e04dfaf c1efbf04 01405828 59bf073a

```
double():
    1c09bf5f 83df7e08 0280b050 b37e0e74

CMAC(ad):
    f1f922b7 f5193ce6 4ff80cb4 7d93f23b

xor:
    edf09de8 76c642ee 4d78bce4 ceedfc4f

double():
    dbe13bd0 ed8c85dc 9af179c9 9ddb819

pad:
    11223344 55667788 99aabbcc ddee8000

xor:
    cac30894 b8eaf254 035bc205 40357819

CMAC(final):
    85632d07 c6e8f37f 950acd32 0a2ecc93

CTR-AES
-----
CTR:
    85632d07 c6e8f37f 150acd32 0a2ecc93

E(K,CTR):
    51e218d2 c5a2ab8c 4345c4a6 23b2f08f

ciphertext:
    40c02b96 90c4dc04 daef7f6a fe5c

output
-----
IV || C:
    85632d07 c6e8f37f 950acd32 0a2ecc93
```

40c02b96 90c4dc04 daef7f6a fe5c

[A.2.](#) Nonce-based Authenticated Encryption Example

Input:

Key:

7f7e7d7c 7b7a7978 77767574 73727170
40414243 44454647 48494a4b 4c4d4e4f

AD1:

00112233 44556677 8899aabb ccddeeff
deaddada deaddada ffeeddcc bbaa9988
77665544 33221100

AD2:

10203040 50607080 90a0

Nonce:

09f91102 9d74e35b d84156c5 635688c0

Plaintext:

74686973 20697320 74686520 706c6169
6e746578 7420746f 20656e63 72797074
20757369 6e672053 49562d41 4553

S2V-CMAC-AES

CMAC(zero):

c8b43b59 74960e7c e6a5dd85 231e591a

double():

916876b2 e92c1cf9 cd4bbb0a 463cb2b3

CMAC(ad1)

3c9b689a b41102e4 80954714 1dd0d15a

xor:

adf31e28 5d3d1e1d 4ddefc1e 5bec63e9

double():

5be63c50 ba7a3c3a 9bbdf83c b7d8c755

CMAC(ad2)

d98c9b0b e42cb2d7 aa98478e d11eda1b

xor:

826aa75b 5e568eed 3125bfb2 66c61d4e

double():
04d54eb6 bcad1dda 624b7f64 cd8c3a1b

CMAC(nonce)
128c62a1 ce3747a8 372c1c05 a538b96d

xor:
16592c17 729a5a72 55676361 68b48376

xorend:
74686973 20697320 736f6d65 20706c61
696e7465 78742074 6f20656e 63727966
2d0c6201 f3341575 342a3745 f5c625

CMAC(final)
7bdb6e3b 432667eb 06f4d14b ff2fbd0f

CTR-AES

CTR:
7bdb6e3b 432667eb 06f4d14b 7f2fbd0f

E(K,CTR):
bff8665c fdd73363 550f7400 e8f9d376

CTR+1:
7bdb6e3b 432667eb 06f4d14b 7f2fbd10

E(K,CTR+1):
b2c9088e 713b8617 d8839226 d9f88159

CTR+2
7bdb6e3b 432667eb 06f4d14b 7f2fbd11

E(K,CTR+2):
9e44d827 234949bc 1b12348e bc195ec7

ciphertext:
cb900f2f ddbbe4043 26601965 c889bf17
dba77ceb 094fa663 b7a3f748 ba8af829
ea64ad54 4a272e9c 485b62a3 fd5c0d

output

IV || C:
7bdb6e3b 432667eb 06f4d14b ff2fbd0f
cb900f2f ddbbe4043 26601965 c889bf17
dba77ceb 094fa663 b7a3f748 ba8af829

Internet-Draft

SIV-AES

November 2007

ea64ad54 4a272e9c 485b62a3 fd5c0d

Author's Address

Dan Harkins (editor)
Aruba Networks

Email: dharkins@arubanetworks.com

Internet-Draft

SIV-AES

November 2007

Full Copyright Statement

Copyright (C) The IETF Trust (2007).

This document is subject to the rights, licenses and restrictions contained in [BCP 78](#), and except as set forth therein, the authors retain all their rights.

This document and the information contained herein are provided on an "AS IS" basis and THE CONTRIBUTOR, THE ORGANIZATION HE/SHE REPRESENTS OR IS SPONSORED BY (IF ANY), THE INTERNET SOCIETY, THE IETF TRUST AND THE INTERNET ENGINEERING TASK FORCE DISCLAIM ALL WARRANTIES, EXPRESS OR IMPLIED, INCLUDING BUT NOT LIMITED TO ANY WARRANTY THAT THE USE OF THE INFORMATION HEREIN WILL NOT INFRINGE ANY RIGHTS OR ANY IMPLIED WARRANTIES OF MERCHANTABILITY OR FITNESS FOR A PARTICULAR PURPOSE.

Intellectual Property

The IETF takes no position regarding the validity or scope of any Intellectual Property Rights or other rights that might be claimed to pertain to the implementation or use of the technology described in this document or the extent to which any license under such rights might or might not be available; nor does it represent that it has made any independent effort to identify any such rights. Information on the procedures with respect to rights in RFC documents can be found in [BCP 78](#) and [BCP 79](#).

Copies of IPR disclosures made to the IETF Secretariat and any assurances of licenses to be made available, or the result of an attempt made to obtain a general license or permission for the use of such proprietary rights by implementers or users of this specification can be obtained from the IETF on-line IPR repository at <http://www.ietf.org/ipr>.

The IETF invites any interested party to bring to its attention any copyrights, patents or patent applications, or other proprietary rights that may cover technology that may be required to implement this standard. Please address the information to the IETF at ietf-ipr@ietf.org.

Acknowledgment

Funding for the RFC Editor function is provided by the IETF Administrative Support Activity (IASA).