

Internet Engineering Task Force
Internet-Draft
Intended status: Experimental
Expires: July 17, 2014

D. Farinacci
lispers.net
P. Lahiri
Juniper Networks
M. Kowal
cisco Systems
January 13, 2014

LISP Traffic Engineering Use-Cases
draft-farinacci-lisp-te-04

Abstract

This document describes how LISP reencapsulating tunnels can be used for Traffic Engineering purposes. The mechanisms described in this document require no LISP protocol changes but do introduce a new locator (RLOC) encoding. The Traffic Engineering features provided by these LISP mechanisms can span intra-domain, inter-domain, or combination of both.

Status of this Memo

This Internet-Draft is submitted in full conformance with the provisions of [BCP 78](#) and [BCP 79](#).

Internet-Drafts are working documents of the Internet Engineering Task Force (IETF). Note that other groups may also distribute working documents as Internet-Drafts. The list of current Internet-Drafts is at <http://datatracker.ietf.org/drafts/current/>.

Internet-Drafts are draft documents valid for a maximum of six months and may be updated, replaced, or obsoleted by other documents at any time. It is inappropriate to use Internet-Drafts as reference material or to cite them other than as "work in progress."

This Internet-Draft will expire on July 17, 2014.

Copyright Notice

Copyright (c) 2014 IETF Trust and the persons identified as the document authors. All rights reserved.

This document is subject to [BCP 78](#) and the IETF Trust's Legal Provisions Relating to IETF Documents (<http://trustee.ietf.org/license-info>) in effect on the date of publication of this document. Please review these documents carefully, as they describe your rights and restrictions with respect

to this document. Code Components extracted from this document must include Simplified BSD License text as described in Section 4.e of the Trust Legal Provisions and are provided without warranty as described in the Simplified BSD License.

Table of Contents

1.	Requirements Language	3
2.	Introduction	4
3.	Definition of Terms	5
4.	Overview	7
5.	Explicit Locator Paths	9
5.1.	ELP Re-optimization	10
5.2.	Using Recursion	10
5.3.	ELP Selection based on Class of Service	11
5.4.	Packet Loop Avoidance	12
6.	Service Chaining	13
7.	RLOC Probing by RTRs	14
8.	Interworking Considerations	15
9.	Multicast Considerations	16
10.	Security Considerations	18
11.	IANA Considerations	19
12.	References	20
12.1.	Normative References	20
12.2.	Informative References	20
Appendix A.	Acknowledgments	22
Appendix B.	Document Change Log	23
B.1.	Changes to draft-farinacci-lisp-te-04.txt	23
B.2.	Changes to draft-farinacci-lisp-te-03.txt	23
B.3.	Changes to draft-farinacci-lisp-te-02.txt	23
B.4.	Changes to draft-farinacci-lisp-te-01.txt	23
B.5.	Changes to draft-farinacci-lisp-te-00.txt	23
	Authors' Addresses	24

1. Requirements Language

The key words "MUST", "MUST NOT", "REQUIRED", "SHALL", "SHALL NOT", "SHOULD", "SHOULD NOT", "RECOMMENDED", "MAY", and "OPTIONAL" in this document are to be interpreted as described in [RFC 2119](#) [[RFC2119](#)].

[2.](#) Introduction

This document describes the Locator/Identifier Separation Protocol (LISP), which provides a set of functions for routers to exchange information used to map from non globally routeable Endpoint Identifiers (EIDs) to routeable Routing Locators (RLOCs). It also defines a mechanism for these LISP routers to encapsulate IP packets addressed with EIDs for transmission across the Internet that uses RLOCs for routing and forwarding.

When LISP routers encapsulate packets to other LISP routers, the path stretch is typically 1, meaning the packet travels on a direct path from the encapsulating ITR to the decapsulating ETR at the destination site. The direct path is determined by the underlying routing protocol and metrics it uses to find the shortest path.

This specification will examine how reencapsulating tunnels [[RFC6830](#)] can be used so a packet can take an administratively specified path, a congestion avoidance path, a failure recovery path, or multiple load-shared paths, as it travels from ITR to ETR. By introducing an Explicit Locator Path (ELP) locator encoding [[LISP-LCAF](#)], an ITR can encapsulate a packet to a Reencapsulating Tunnel Router (RTR) which decapsulates the packet, then encapsulates it to the next locator in the ELP.

3. Definition of Terms

Endpoint ID (EID): An EID is a 32-bit (for IPv4) or 128-bit (for IPv6) value used in the source and destination address fields of the first (most inner) LISP header of a packet. The host obtains a destination EID the same way it obtains an destination address today, for example through a Domain Name System (DNS) [[RFC1034](#)] lookup or Session Invitation Protocol (SIP) [[RFC3261](#)] exchange. The source EID is obtained via existing mechanisms used to set a host's "local" IP address. An EID used on the public Internet must have the same properties as any other IP address used in that manner; this means, among other things, that it must be globally unique. An EID is allocated to a host from an EID-prefix block associated with the site where the host is located. An EID can be used by a host to refer to other hosts. EIDs MUST NOT be used as LISP RLOCs. Note that EID blocks MAY be assigned in a hierarchical manner, independent of the network topology, to facilitate scaling of the mapping database. In addition, an EID block assigned to a site may have site-local structure (subnetting) for routing within the site; this structure is not visible to the global routing system. In theory, the bit string that represents an EID for one device can represent an RLOC for a

different device. As the architecture is realized, if a given bit string is both an RLOC and an EID, it must refer to the same entity in both cases. When used in discussions with other Locator/ID separation proposals, a LISP EID will be called a "LEID". Throughout this document, any references to "EID" refers to an LEID.

Routing Locator (RLOC): A RLOC is an IPv4 [[RFC0791](#)] or IPv6 [[RFC2460](#)] address of an egress tunnel router (ETR). A RLOC is the output of an EID-to-RLOC mapping lookup. An EID maps to one or more RLOCs. Typically, RLOCs are numbered from topologically-aggregatable blocks that are assigned to a site at each point to which it attaches to the global Internet; where the topology is defined by the connectivity of provider networks, RLOCs can be thought of as PA addresses. Multiple RLOCs can be assigned to the same ETR device or to multiple ETR devices at a site.

Reencapsulating Tunnel Router (RTR): An RTR is a router that acts as an ETR (or PETR) by decapsulating packets where the destination address in the "outer" IP header is one of its own RLOCs. Then acts as an ITR (or PITR) by making a decision where to encapsulate the packet based on the next locator in the ELP towards the final destination ETR.

Explicit Locator Path (ELP): The ELP is an explicit list of RLOCs for each RTR a packet must travel to along its path toward a final destination ETR (or PETR). The list is a strict ordering where each RLOC in the list is visited. However, the path from one RTR to another is determined by the underlying routing protocol and how the infrastructure assigns metrics and policies for the path.

Recursive Tunneling: Recursive tunneling occurs when a packet has more than one LISP IP header. Additional layers of tunneling MAY be employed to implement traffic engineering or other re-routing as needed. When this is done, an additional "outer" LISP header is added and the original RLOCs are preserved in the "inner" header. Any references to tunnels in this specification refers to dynamic encapsulating tunnels and they are never statically configured.

Reencapsulating Tunnels: Reencapsulating tunneling occurs when an ETR removes a LISP header, then acts as an ITR to prepend another LISP header. Doing this allows a packet to be re-routed by the reencapsulating router without adding the overhead of additional tunnel headers. Any references to tunnels in this specification refers to dynamic encapsulating tunnels and they are never statically configured. When using multiple mapping database systems, care must be taken to not create reencapsulation loops through misconfiguration.

[4.](#) Overview

Typically, a packet's path from source EID to destination EID travels through the locator core via the encapsulating ITR directly to the decapsulating ETR as the following diagram illustrates:

Legend:

seid: Packet is originated by source EID 'seid'.

deid: Packet is consumed by destination EID 'deid'.

A,B,C,D : Core routers in different ASes.

---> : The physical topological path between two routers.

==> : A multi-hop LISP dynamic tunnel between LISP routers.

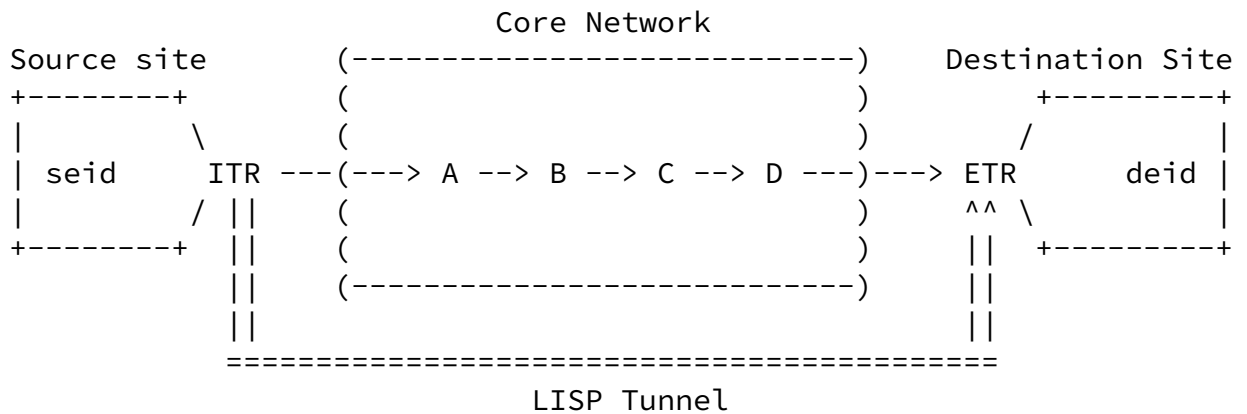

Typical Data Path from ITR to ETR

Let's introduce RTRs 'X' and 'Y' so that, for example, if it is desirable to route around the path from B to C, one could provide an ELP of (X,Y,etr):

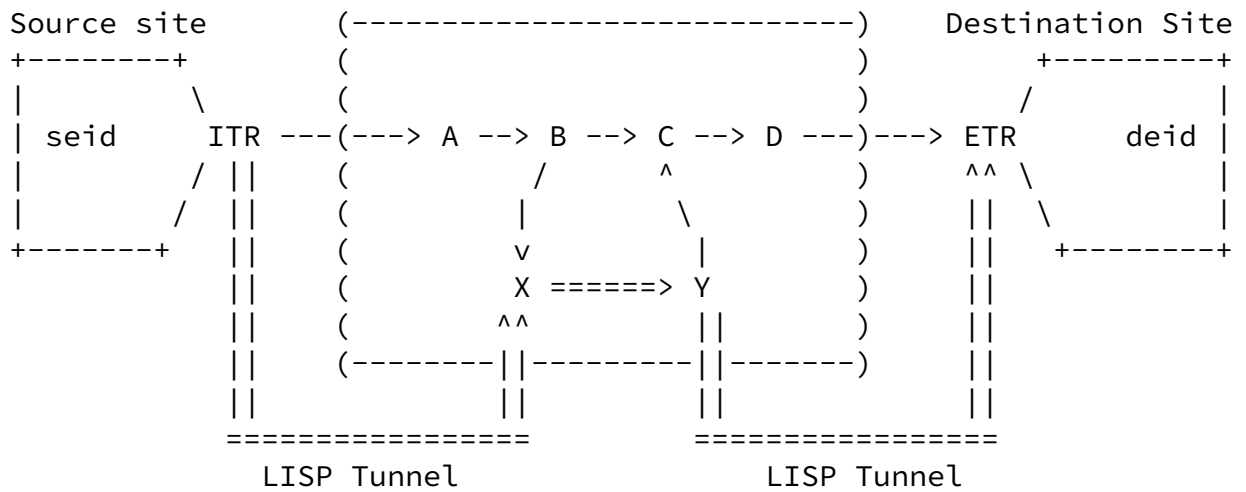

ELP tunnel path ITR ==> X, then X ==> Y, and then Y ==> ETR

There are various reasons why the path from 'seid' to 'deid' may want to avoid the path from B to C. To list a few:

- o There may not be sufficient capacity provided by the networks that connect B and C together.
- o There may be a policy reason to avoid the ASes that make up the path between B and C.
- o There may be a failure on the path between B and C which makes the path unreliable.
- o There may be monitoring or traffic inspection resources close to RTRs X and Y that do network accounting or measurement.
- o There may be a chain of services performed at RTRs X and Y regardless if the path from ITR to ETR is through B and C.

5. Explicit Locator Paths

The notation for a general formatted ELP is (x, y, etr) which represents the list of RTRs a packet SHOULD travel through to reach the final tunnel hop to the ETR.

The procedure for using an ELP at each tunnel hop is as follows:

1. The ITR will retrieve the ELP from the mapping database.
2. The ITR will encapsulate the packet to RLOC 'x'.
3. The RTR with RLOC 'x' will decapsulate the packet. It will use the decapsulated packet's destination address as a lookup into the mapping database to retrieve the ELP.
4. RTR 'x' will encapsulate the packet to RTR with RLOC 'y'.
5. The RTR with RLOC 'y' will decapsulate the packet. It will use the decapsulated packet's destination address as a lookup into the mapping database to retrieve the ELP.
6. RTR 'y' will encapsulate the packet on the final tunnel hop to ETR with RLOC 'etr'.
7. The ETR will decapsulate the packet and deliver the packet to the EID inside of its site.

The specific format for the ELP can be found in [[LISP-LCAF](#)]. It is defined that an ELP will appear as a single encoded locator in a locator-set. Say for instance, we have a mapping entry for EID-prefix 10.0.0.0/8 that is reachable via 4 locators. Two locators are being used as active/active and the other two are used as active/active if the first two go unreachable (as noted by the priority assignments below). This is what the mapping entry would look like:

```
EID-prefix: 10.0.0.0/8
Locator-set: ETR-A: priority 1, weight 50
             ETR-B: priority 1, weight 50
             ETR-C: priority 2, weight 50
             ETR-D: priority 2, weight 50
```

If an ELP is going to be used to have a policy path to ETR-A and possibly another policy path to ETR-B, the locator-set would be encoded as follows:

Internet-Draft

LISP Traffic Engineering Use-Cases

January 2014

```
EID-prefix: 10.0.0.0/8
Locator-set: (x, y, ETR-A): priority 1, weight 50
              (q, r, ETR-B): priority 1, weight 50
              ETR-C:          priority 2, weight 50
              ETR-D:          priority 2, weight 50
```

The mapping entry with ELP locators is registered to the mapping database system just like any other mapping entry would. The registration is typically performed by the ETR(s) that are assigned and own the EID-prefix. That is, the destination site makes the choice of the RTRs in the ELP. However, it may be common practice for a provisioning system to program the mapping database with ELPs.

Another case where a locator-set can be used for flow-based load-sharing across multiple paths to the same destination site:

```
EID-prefix: 10.0.0.0/8
Locator-set: (x, y, ETR-A): priority 1, weight 75
              (q, r, ETR-A): priority 1, weight 25
```

Using this mapping entry, an ITR would load split 75% of the EID flows on the (x, y, ETR-A) ELP path and 25% of the EID flows on the (q, r, ETR-A) ELP path. If any of the ELPs go down, then the other can take 100% of the load.

[5.1.](#) ELP Re-optimization

ELP re-optimization is a process of changing the RLOCs of an ELP due to underlying network change conditions. Just like when there is any locator change for a locator-set, the procedures from the main LISP specification [[RFC6830](#)] are followed.

When a RLOC from an ELP is changed, Map-Notify messages [[RFC6833](#)] can be used to inform the existing RTRs in the ELP so they can do a lookup to obtain the latest version of the ELP. Map-Notify messages can also be sent to new RTRs in an ELP so they can get the ELP in advance to receiving packets that will use the ELP. This can minimize packet loss during mapping database lookups in RTRs.

[5.2.](#) Using Recursion

In the previous examples, we showed how an ITR encapsulates using an ELP of (x, y, etr). When a packet is encapsulated from the ITR to RTR 'x', the RTR may want a policy path to RTR 'y' and run another level of reencapsulating tunnels for packets destined to RTR 'y'. In this case, RTR 'x' does not decapsulate packets from the ITR, but rather performs a mapping database lookup on the address 'y'. This

can be done when using a public or private mapping database. The decision to use address 'y' as an encapsulation address versus a lookup address is based on the L-bit setting for 'y' in the ELP entry. The decision and policy of ELP encodings are local to the entity which registers the EID-prefix associated with the ELP.

Another example of recursion is when the ITR uses the ELP (x, y, etr) to first prepend a header with a destination RLOC of the ETR and then prepend another header and encapsulate the packet to RTR 'x'. When RTR 'x' decapsulates the packet, rather than doing a mapping database lookup on RTR 'y' the last example showed, instead RTR 'x' does a mapping database lookup on ETR 'etr'. In this scenario, RTR 'x' can choose an ELP from the locator-set by considering the source RLOC address of the ITR versus considering the source EID.

This additional level of recursion also brings advantages for the provider of RTR 'x' to store less state. Since RTR 'x' does not need to look at the inner most header, it does not need to store EID state. It only stores an entry for RTR 'y' which many EID flows could share for scaling benefits. The locator-set for entry 'y' could either be a list of typical locators, a list of ELPs, or combination of both. Another advantage is that packet load-splitting can be accomplished by examining the source of a packet. If the source is an ITR versus the source being the last-hop of an ELP the last-hop selected, different forwarding paths can be used.

[5.3.](#) ELP Selection based on Class of Service

Paths to an ETR may want to be selected based on different classes of service. Packets from a set of sources that have premium service can use ELP paths that are less congested where normal sources use ELP paths that compete for less resources or use longer paths for best

effort service.

Using source/destination lookups into the mapping database can yield different ELPs. So for example, a premium service flow with (source=1.1.1.1, dest=10.1.1.1) can be described by using the following mapping entry:

```
EID-prefix: (1.0.0.0/8, 10.0.0.0/8)
Locator-set: (x, y, ETR-A): priority 1, weight 50
              (q, r, ETR-A): priority 1, weight 50
```

And all other best-effort sources would use different mapping entry described by:

```
EID-prefix: (0.0.0.0/0, 10.0.0.0/8)
Locator-set: (x, x', y, y', ETR-A): priority 1, weight 50
              (q, q', r, r', ETR-A): priority 1, weight 50
```

If the source/destination lookup is coupled with recursive lookups, then an ITR can encapsulate to the ETR, prepending a header that selects source address ITR-1 based on the premium class of service source, or selects source address ITR-2 for best-effort sources with normal class of service. The ITR then does another lookup in the mapping database on the prepended header using lookup key (source=ITR-1, dest=10.1.1.1) that returns the following mapping entry:

```
EID-prefix: (ITR-1, 10.0.0.0/8)
Locator-set: (x, y, ETR-A): priority 1, weight 50
              (q, r, ETR-A): priority 1, weight 50
```

And all other sources would use different mapping entry with a lookup key of (source=ITR-2, dest=10.1.1.1):

```
EID-prefix: (ITR-2, 10.0.0.0/8)
Locator-set: (x, x', y, y', ETR-A): priority 1, weight 50
              (q, q', r, r', ETR-A): priority 1, weight 50
```

This will scale the mapping system better by having fewer source/destination combinations. Refer to the Source/Dest LCAF type described in [[LISP-LCAF](#)] for encoding EIDs in Map-Request and Map-Register messages.

[5.4.](#) Packet Loop Avoidance

An ELP that is first used by an ITR must be inspected for encoding loops. If any RLOC appears twice in the ELP, it MUST not be used.

Since it is expected that multiple mapping systems will be used, there can be a loop across ELPs when registered in different mapping systems. The TTL copying procedures for reencapsulating tunnels and recursive tunnels in [[RFC6830](#)] MUST be followed.

[6.](#) Service Chaining

An ELP can be used to deploy services at each reencapsulation point in the network. One example is to implement a scrubber service when a destination EID is being DoS attacked. That is, when a DoS attack is recognized when the encapsulation path is between ITR and ETR, an ELP can be registered for a destination EID to the mapping database system. The ELP can include an RTR so the ITR can encapsulate packets to the RTR which will decapsulate and deliver packets to a scrubber service device. The scrubber could decide if the offending packets are dropped or allowed to be sent to the destination EID. In which case, the scrubber delivers packets back to the RTR which encapsulates to the ETR.

7. RLOC Probing by RTRs

Since an RTR knows the next tunnel hop to encapsulate to, it can monitor the reachability of the next-hop RTR RLOC by doing RLOC-probing according to the procedures in [[RFC6830](#)]. When the RLOC is determined unreachable by the RLOC-probing mechanisms, the RTR can use another locator in the locator-set. That could be the final ETR, a RLOC of another RTR, or an ELP where it must search for itself and use the next RLOC in the ELP list to encapsulate to.

RLOC-probing can also be used to measure delay on the path between

RTRs and when it is desirable switch to another lower delay ELP.

Farinacci, et al. Expires July 17, 2014 [Page 14]

Internet-Draft LISP Traffic Engineering Use-Cases January 2014

[8.](#) Interworking Considerations

[RFC6832] defines procedures for how non-LISP sites talk to LISP sites. The network elements defined in the Interworking

specification, the proxy ITR (PITR) and proxy ETR (PETR) (as well as their multicast counterparts defined in [[RFC6831](#)]) can participate in LISP-TE. That is, a PITR and a PETR can appear in an ELP list and act as an RTR.

Note when an RLOC appears in an ELP, it can be of any address-family. There can be a mix of IPv4 and IPv6 locators present in the same ELP. This can provide benefits where islands of one address-family or the other are supported and connectivity across them is necessary. For instance, an ELP can look like:

```
(x4, a46, b64, y4, etr)
```

Where an IPv4 ITR will encapsulate using an IPv4 RLOC 'x4' and 'x4' could reach an IPv4 RLOC 'a46', but RTR 'a46' encapsulates to an IPv6 RLOC 'b64' when the network between them is IPv6-only. Then RTR 'b64' encapsulates to IPv4 RLOC 'y4' if the network between them is dual-stack.

Note that RTRs can be used for NAT-traversal scenarios [[LISP-NATT](#)] as well to reduce the state in both an xTR that resides behind a NAT and the state the NAT needs to maintain. In this case, the xTR only needs a default map-cache entry pointing to the RTR for outbound traffic and all remote ITRs can reach EIDs through the xTR behind a NAT via a single RTR (or a small set RTRs for redundancy).

RTRs have some scaling features to reduce the number of locator-set changes, the amount of state, and control packet overhead:

- o When ITRs and PITRs are using a small set of RTRs for encapsulating to "orders of magnitude" more EID-prefixes, the probability of locator-set changes are limited to the RTR RLOC changes versus the RLOC changes for the ETRs associated with the EID-prefixes if the ITRs and PITRs were directly encapsulating to the ETRs. This comes at an expense in packet stretch, but depending on RTR placement, this expense can be mitigated.
- o When RTRs are on-path between many pairwise EID flows, ITRs and PITRs can store a small number of coarse EID-prefixes.
- o RTRs can be used to help scale RLOC-probing. Instead of ITRs RLOC-probing all ETRs for each destination site it has cached, the ITRs can probe a smaller set of RTRs which in turn, probe the destination sites.

9. Multicast Considerations

ELPs have application in multicast environments. Just like RTRs can be used to provide connectivity across different address family islands, RTRs can help concatenate a multicast region of the network to one that does not support native multicast.

Note there are various combinations of connectivity that can be accomplished with the deployment of RTRs and ELPs:

- o Providing multicast forwarding between IPv4-only-unicast regions and IPv4-multicast regions.
- o Providing multicast forwarding between IPv6-only-unicast regions and IPv6-multicast regions.
- o Providing multicast forwarding between IPv4-only-unicast regions and IPv6-multicast regions.
- o Providing multicast forwarding between IPv6-only-unicast regions and IPv4-multicast regions.
- o Providing multicast forwarding between IPv4-multicast regions and IPv6-multicast regions.

An ITR or PITR can do a (S-EID,G) lookup into the mapping database. What can be returned is a typical locator-set that could be made up of the various RLOC addresses:

```
Multicast EID key: (seid, G)
Locator-set:      ETR-A: priority 1, weight 25
                  ETR-B: priority 1, weight 25
                  g1:   priority 1, weight 25
                  g2:   priority 1, weight 25
```

An entry for host 'seid' sending to application group 'G'

The locator-set above can be used as a replication list. That is some RLOCs listed can be unicast RLOCs and some can be delivery group RLOCs. A unicast RLOC in this case is used to encapsulate a multicast packet originated by a multicast source EID into a unicast packet for unicast delivery on the underlying network. ETR-A could be a IPv4 unicast RLOC address and ETR-B could be a IPv6 unicast RLOC address.

A delivery group address is used when a multicast packet originated

by a multicast source EID is encapsulated in a multicast packet for

multicast delivery on the underlying network. Group address 'g1' could be a IPv4 delivery group RLOC and group address 'g2' could be an IPv6 delivery group RLOC.

Flexibility for these various types of connectivity combinations can be achieved and provided by the mapping database system. And the RTR placement allows the connectivity to occur where the differences in network functionality are located.

Extending this concept by allowing ELPs in locator-sets, one could have this locator-set registered in the mapping database for (seid, G). For example:

```
Multicast EID key: (seid, G)
Locator-set:      (x, y, ETR-A):  priority 1, weight 50
                  (a, g, b, ETR-B): priority 1, weight 50
```

Using ELPs for multicast flows

In the above situation, an ITR would encapsulate a multicast packet originated by a multicast source EID to the RTR with unicast RLOC 'x'. Then RTR 'x' would decapsulate and unicast encapsulate to RTR 'y' ('x' or 'y' could be either IPv4 or IPv6 unicast RLOCs), which would decapsulate and unicast encapsulate to the final RLOC 'ETR-A'. The ETR 'ETR-A' would decapsulate and deliver the multicast packet natively to all the receivers joined to application group 'G' inside the LISP site.

Let's look at the ITR using the ELP (a, g, b, ETR-B). Here the encapsulation path would be the ITR unicast encapsulates to unicast RLOC 'a'. RTR 'a' multicast encapsulates to delivery group 'g'. The packet gets to all ETRs that have joined delivery group 'g' so they can deliver the multicast packet to joined receivers of application group 'G' in their sites. RTR 'b' is also joined to delivery group 'g'. Since it is in the ELP, it will be the only RTR that unicast encapsulates the multicast packet to ETR 'ETR-B'. Lastly, 'ETR-B' decapsulates and delivers the multicast packet to joined receivers to application group 'G' in its LISP site.

As one can see there are all sorts of opportunities to provide multicast connectivity across a network with non-congruent support for multicast and different address-families. One can also see how using the mapping database can allow flexible forms of delivery policy, rerouting, and congestion control management in multicast environments.

[10.](#) Security Considerations

When an RTR receives a LISP encapsulated packet, it can look at the outer source address to verify that RLOC is the one listed as the previous hop in the ELP list. If the outer source RLOC address appears before the RLOC which matches the outer destination RLOC address, the decapsulating RTR (or ETR if last hop), MAY choose to drop the packet.

[11](#). IANA Considerations

At this time there are no requests for IANA.

[12.](#) References

[12.1.](#) Normative References

- [RFC0791] Postel, J., "Internet Protocol", STD 5, [RFC 791](#), September 1981.
- [RFC1034] Mockapetris, P., "Domain names - concepts and facilities", STD 13, [RFC 1034](#), November 1987.
- [RFC2119] Bradner, S., "Key words for use in RFCs to Indicate Requirement Levels", [BCP 14](#), [RFC 2119](#), March 1997.
- [RFC2460] Deering, S. and R. Hinden, "Internet Protocol, Version 6 (IPv6) Specification", [RFC 2460](#), December 1998.
- [RFC3261] Rosenberg, J., Schulzrinne, H., Camarillo, G., Johnston, A., Peterson, J., Sparks, R., Handley, M., and E. Schooler, "SIP: Session Initiation Protocol", [RFC 3261](#),

June 2002.

- [RFC6830] Farinacci, D., Fuller, V., Meyer, D., and D. Lewis, "The Locator/ID Separation Protocol (LISP)", [RFC 6830](#), January 2013.
- [RFC6831] Farinacci, D., Meyer, D., Zwiebel, J., and S. Venaas, "The Locator/ID Separation Protocol (LISP) for Multicast Environments", [RFC 6831](#), January 2013.
- [RFC6832] Lewis, D., Meyer, D., Farinacci, D., and V. Fuller, "Interworking between Locator/ID Separation Protocol (LISP) and Non-LISP Sites", [RFC 6832](#), January 2013.
- [RFC6833] Fuller, V. and D. Farinacci, "Locator/ID Separation Protocol (LISP) Map-Server Interface", [RFC 6833](#), January 2013.

12.2. Informative References

- [LISP-LCAF] Farinacci, D., Meyer, D., and J. Snijders, "LISP Canonical Address Format", [draft-ietf-lisp-lcaf-03.txt](#) (work in progress).
- [LISP-NATT] Ermagan, V., Farinacci, D., Lewis, D., Skriver, J., Maino, F., and C. White, "NAT traversal for LISP", [draft-ermagan-lisp-nat-traversal-04.txt](#) (work in progress).

[Appendix A](#). Acknowledgments

The authors would like to thank the following people for their ideas and comments. They are Albert Cabellos, Khalid Raza, and Vina Ermagan, and Gregg Schudel.

[Appendix B](#). Document Change Log

[B.1](#). Changes to [draft-farinacci-lisp-te-04.txt](#)

- o Resubmitted draft due to document timeout.
- o Updated Informative References section.

[B.2](#). Changes to [draft-farinacci-lisp-te-03.txt](#)

- o Update LISP references to their RFC pointers and document timer.

[B.3](#). Changes to [draft-farinacci-lisp-te-02.txt](#)

- o Update references and document timer.

[B.4](#). Changes to [draft-farinacci-lisp-te-01.txt](#)

- o Posted July 2012.
- o Add the Lookup bit to allow an ELP to be a list of encapsulation and/or mapping database lookup addresses.
- o Indicate that ELPs can be used for service chaining.
- o Add text to indicate that Map-Notify messages can be sent to new RTRs in a ELP so their map-caches can be pre-populated to avoid mapping database lookup packet loss.
- o Fixes to editorial comments from Gregg.

[B.5](#). Changes to [draft-farinacci-lisp-te-00.txt](#)

- o Initial draft posted March 2012.

Internet-Draft

LISP Traffic Engineering Use-Cases

January 2014

Authors' Addresses

Dino Farinacci
lispers.net
San Jose, California
USA

Phone: 408-718-2001
Email: farinacci@gmail.com

Parantap Lahiri
Juniper Networks
Sunnyvale, CA
USA

Email: parantap.lahiri@gmail.com

Michael Kowal
cisco Systems
111 Wood Avenue South
ISELIN, NJ
USA

Email: mikowal@cisco.com

