

Network Working Group
Internet Draft
Intended status: Standards Track

D. Fedyk
D. Beller
Lieven Levrau
Alcatel-Lucent
D. Ceccarelli
Ericsson
F. Zhang
Huawei Technologies
Y. Tochio
Fujitsu
X. Fu
ZTE

Expires: January 16, 2014

July 15, 2013

UNI Extensions for Diversity and Latency Support
draft-fedyk-ccamp-uni-extensions-02.txt

Status of this Memo

This Internet-Draft is submitted in full conformance with the provisions of [BCP 78](#) and [BCP 79](#).

Internet-Drafts are working documents of the Internet Engineering Task Force (IETF), its areas, and its working groups. Note that other groups may also distribute working documents as Internet-Drafts.

Internet-Drafts are draft documents valid for a maximum of six months and may be updated, replaced, or obsoleted by other documents at any time. It is inappropriate to use Internet-Drafts as reference material or to cite them other than as "work in progress."

The list of current Internet-Drafts can be accessed at <http://www.ietf.org/ietf/lid-abstracts.txt>

The list of Internet-Draft Shadow Directories can be accessed at <http://www.ietf.org/shadow.html>

Internet-Draft

[draft-fedyk-ccamp-uni-extensions](#)

July 2013

Copyright Notice

Copyright (c) 2013 IETF Trust and the persons identified as the document authors. All rights reserved.

This document is subject to [BCP 78](#) and the IETF Trust's Legal Provisions Relating to IETF Documents (<http://trustee.ietf.org/license-info>) in effect on the date of publication of this document. Please review these documents carefully, as they describe your rights and restrictions with respect to this document. Code Components extracted from this document must include Simplified BSD License text as described in Section 4.e of the Trust Legal Provisions and are provided without warranty as described in the Simplified BSD License.

Abstract

This document builds on the GMPLS overlay model [[RFC4208](#)] and defines extensions to the GMPLS User-Network Interface (UNI) to support route diversity within the core network for sets of LSPs initiated by edge nodes. A particular example where route diversity within the core network is desired, are dual-homed edge nodes. The document also defines GMPLS UNI extensions to deal with latency requirements for edge node initiated LSPs.

This document uses a VPN model that is based on the same premise as L1VPN framework [[RFC4847](#)] but may also be applied to other technologies. The extensions are applicable both to VPN and non VPN environments. These extensions move the UNI from basic connectivity to enhanced mode connectivity by including additional constraints while minimizing the exchange of CE to PE information. These extensions are applicable to the overlay extension service model. Route Diversity for customer LSPs are a common requirement applicable to L1VPNs. The UNI mechanisms described in this document are L1VPN compatible and can be applied to achieve diversity for sets of customer LSPs.

The UNI extensions in support of latency constraints can also be applied to the extended overlay service model in order for the customer LSPs to meet certain latency requirements.

Table of Contents

1.	Introduction	3
2.	Conventions used in this document	4
3.	Contributors	4
4.	LSP Diversity in the Overlay Extension Service Model	4
4.1.	LSP diversity for dual-homed customer edge (CE) devices	5
4.1.1.	Exchanging SRLG information between the PEs via the CE device	8
4.1.1.1.	Operational Procedures	8
4.1.1.2.	Error Handling Procedures	9
4.1.2.	Using Path Affinity Set Extension	10
4.1.2.1.	Operational Procedures	13
4.1.2.2.	Error Handling Procedures	13
4.1.2.3.	Distribution of the Path Affinity Set Information	14
5.	Latency Signaling Extensions	15
5.1.	RSVP-TE Extensions	16
5.2.	Operational Procedures	16
5.3.	Error Handling Procedures	16
6.	Security Considerations	16
7.	IANA Considerations	17
8.	References	17
8.1.	Normative References	17
8.2.	Informative References	17
	Authors' Addresses	19

[1.](#) Introduction

This document builds on the GMPLS overlay model [[RFC4208](#)] and defines extensions to the GMPLS User-Network Interface (UNI) to support route diversity within the core network for sets of LSPs initiated by edge nodes. In the following, the term customer edge (CE) device is used synonymously for the term edge node (EN) as in [[RFC4208](#)].

Moreover, the VPN terminology (CE and PE) [[RFC4026](#)] is used below when the core network is a VPN but is also applicable to UNI interfaces [[RFC4208](#)].

This document uses a VPN model that is based on the same premise as L1VPN framework [[RFC4847](#)] but may also be applied to other technologies. The extensions are applicable both to VPN and non VPN environments. These extensions move the UNI from basic connectivity to enhanced mode connectivity by including additional constraints while minimizing the exchange of CE to PE information. These extensions are applicable to the overlay extension service model.

The overlay model assumes a UNI interface between the edge nodes of the respective transport domains. Route diversity for LSPs from single homed CE and dual-home CEs is a common requirement in optical transport networks. This document describes two signaling variations that may be used for supporting LSP diversity within the overlay extension service model considering dual-homing. Dual-homing is typically used to avoid a single point of failure (UNI link, PE) or if two disjoint connections are forming a protection group in the CE device, e.g., 1+1 protection. While both methods are similar in that they utilize common mechanisms in the PE network to achieve diversity, they are distinguished according to whether the CE is permitted to retrieve provider SRLG diversity information for an LSP from a PE1 and pass it on to a PE2 (SRLG information is shared with the CE), or whether a new attribute is used that allows the PE2 that receives this attribute to derive the SRLG information for an LSP based on the attribute value. Figure 1 below is depicting the scenario.

The extended overlay service model can support other extensions for VPN signaling, for example, those related to latency. When requesting diverse LSPs, latency may also be an additional requirement.

2. Conventions used in this document

The key words "MUST", "MUST NOT", "REQUIRED", "SHALL", "SHALL NOT", "SHOULD", "SHOULD NOT", "RECOMMENDED", "MAY", and "OPTIONAL" in this document are to be interpreted as described in [RFC-2119](#) [[RFC2119](#)].

In this document, these words will appear with that interpretation

only when in ALL CAPS. Lower case uses of these words are not to be interpreted as carrying [RFC-2119](#) significance.

3. Contributors

The Authors would like to thank Eve Varma and Sergio Belotti for their review and contributions to this document.

4. LSP Diversity in the Overlay Extension Service Model

The L1VPN Framework [[RFC4847](#)] (Enhanced Mode) describes the overlay extension service model, which builds upon the UNI Overlay [[RFC4208](#)] serving as the interface between the CE edge node and the PE edge node. In this service model, a CE receives a list of CE-PE TE link addresses to which it can request a L1VPN connection (i.e., membership information) and may include additional information concerning these TE links. This document further builds on the overlay extension service model by adding shared constraint information for path diversity in the optical transport network.

While the L1VPN for optical transport is an example specific VPN technology the term VPN is used generically since the extensions can apply to GMPLS UNIs and VPNs for other technologies.

Two signaling variations are outlined here that may be used for supporting LSP diversity within the overlay extension service model considering dual-homing. While both methods utilize common mechanisms in the PE network to achieve diversity, they are distinguished according to whether the CE is permitted to retrieve provider SRLG diversity information for an LSP from a PE1 and pass it on to a PE2 (SRLG information is shared with the CE or whether a new attribute is used that allows the PE2 that receives this attribute to derive the SRLG information for an LSP based on this attribute value. The selection between these methods is governed by both PE-network specific policies and approaches taken (i.e., in terms of how the provider chooses to perform routing internal to their network).

The first method (see 3.1.1) assumes that provider Shared Resource Link Group (SRLG) Identifier information is both available and shareable (policy decision) with the CE. Since SRLG IDs can then be used (passed transparently between PEs via the dual-homed CE) as signaled information on a UNI message, a mechanism supporting LSP

diversity for the overlay extension service model can be provided via straightforward signaling extensions.

The second method (see 3.1.2) assumes that provider SRLG IDs are either not available or not shareable (based on provider network operator policy) with the CE. For this case, a mechanism is provided where information signaled to the PE on UNI messages does not require shared knowledge of provider SRLG IDs to support LSP diversity for the overlay extension model.

While both methods could be implemented in the same PE network, it is likely that a GMPLS VPN CE network would use only one mechanism at a time.

[4.1](#). LSP diversity for dual-homed customer edge (CE) devices

Single-homed CE devices are connected to a single PE device via a single UNI link (could be a bundle of parallel links which are typically using the same fiber cable). This single UNI link may constitute a single point of failure. Such a single point of failure can be avoided when the CE device is connected to two PE devices via two UNI interfaces as depicted for CE1 in Figure 1 below.

For the dual-homing case, it is possible to establish two connections from the source CE device to the same destination CE device where one connection is using one UNI link to, for example, PE1 and the other

connection is using the UNI link to PE2. In order to avoid single points of failure within the provider network, it is necessary to also ensure path (LSP) diversity within the provider network in order to achieve end-to-end diversity for the two LSPs between the two CE devices. This document describes how it is possible to enable such path diversity to be achieved within the provider network (which is subject to additional routing constraints). [\[RFC4202\]](#) defines SRLG information that can be used to allow GMPLS to provide path diversity in a GMPLS controlled transport network. As the two connections are entering the provider network at different PE devices, the PE device that receives the connection request for the second connection needs to be capable of determining the additional path computation constraints such that the path of the second LSP is disjoint with respect to the already established first connection entering the network at a different PE device. The methods described in this

document allow a PE device to determine the SRLG information for a connection in the provider network that is entering the network on a different PE device.

PE SRLG information can be used directly by a CE if the CE understands the context, and the CE view is limited to its VPN context. In this case, there is a dependency on the provider information and there is a need to be able to query the SRLG in the provider network.

It may, on the other hand, be preferable to avoid this dependency and to decouple the SRLG identifier space used in the provider network from the SRLG space used in the client network. This is possible with both methods detailed below. Even for the method where provider SRLG information is passing through the CE device (note the CE device does not need to process and decode this information) the two SRLG identifier spaces can remain fully decoupled and the operator of the client network is free to assign SRLG identifiers from the client SRLG identifier space to the CE to CE connection that is passing through the provider network.

Referring to Figure 1, the UNI signaling mechanism must support at least one of the two mechanisms described in this document for CE dual homing to achieve LSP diversity in the provider network.

The described mechanisms can also be applied to a scenario where two CE devices are connected to two different PE devices. In this case, the additional information that is exchanged across the UNI interfaces also needs to be exchanged between the two CE devices in order to achieve the desired diversity in the provider network.

This information may be configured or exchanged by some automated

mechanism not described in this document.

In the dual-homing example, CE1 can locally correlate the LSP requests. For the slightly more complicated example involving CE2 and CE3, both requiring a path that shall be diverse to a connection initiated by the other CE device, CE2 and CE3 need to have a common view of the SRLG information to be signaled. In this document, we detail the required diversity information and the signaling of this

diversity information; however, the means for distributing this information within the PE domain or the CE domain is out of scope.

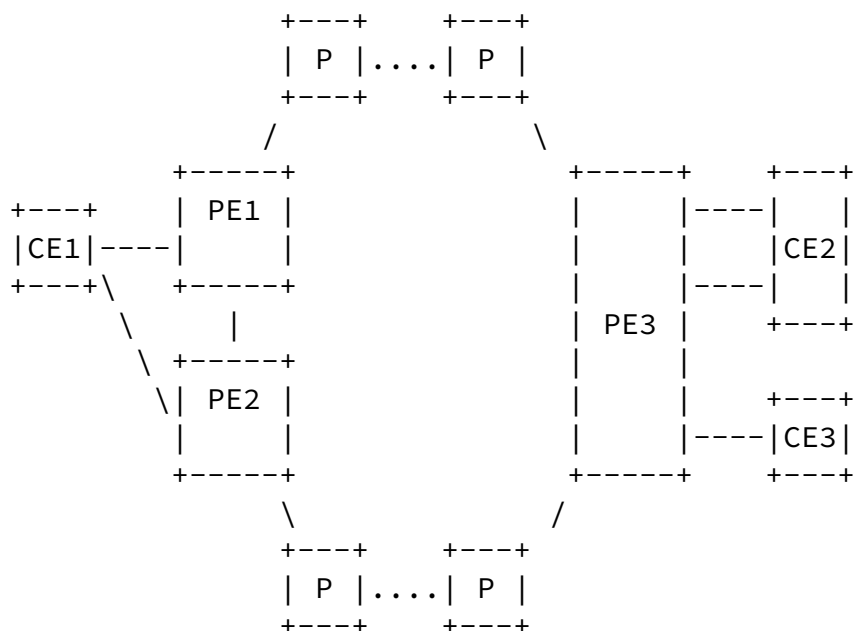

Figure 1 Overlay Reference Diagram

In an overlay model, the information exchanged between the CE and the PE is kept to a minimum.

How diversity is achieved, in terms of configuration, distribution and usage in each part of the transport networks should be kept independent and separate from how diversity is signaled at the UNI between the two transport networks.

Signaling parameters discussed in this document are:

- o SRLG information (see [[RFC4202](#)])
- o Path Affinity Set

SRLG information is defined in [[RFC4202](#)] and if the SRLG information of an LSP is known, it can be used to calculate a path for another LSP that is SRLG diverse with respect to an existing LSP. SRLG information is an unordered list of SRLGs. SRLG information is normally not shared between the transport network and the client network; i.e., not shared with the CEs of a VPN in the VPN context. However, this becomes more challenging when a CE is dual-homed. For example, CE1 in Figure 1 may have requested an LSP1 from CE1 to CE2 via PE1 and PE3. CE1 could subsequently request an LSP2 to CE2 via PE2 and PE3 with the requirement that it should be maximally SRLG disjoint with respect to LSP1. Since PE2 does not have any information about LSP1, PE2 would need to know the SRLG information associated with LSP1. If CE1 could request the SRLG information of LSP1 from PE1, it could then transparently pass this information to PE2 as part of the LSP2 setup request, and PE2 would now be capable of calculating a path for LSP2 that is SRLG disjoint with respect to LSP1.

The exchange of SRLG information is achieved on a per VPN LSP basis using the existing RSVP-TE signaling procedures. It can be exchanged in the PATH (exclusion information) or RESV message in the original request or it can be requested by the CE at any time the path is active.

It shall be noted that SRLG information is an unordered list of SRLG identifiers and the encoding of SRLG information for RSVP signaling is already defined in [[SRLG_info](#)]. Even if SRLG information is known for several LSPs it is not possible for the CEs to derive the provider network topology from this information.

[4.1.1.1](#). Operational Procedures

Retrieving SRLG information from a PE for an existing LSP:

When a dual-homed CE device intends to establish an LSP to the same destination CE device via another PE node, it can request the SRLG information for an already established LSP by setting the SRLG information flag in the LSP attributes sub-object of the RSVP PATH message (IANA to assign the new SRLG flag). As long as the SRLG information flag is set in the PATH message, the PE node inserts the

SRLG sub-object as defined in [[SRLG info](#)] into the RSVP RESV message that contains the current SRLG information for the LSP. If the provider network's policy has been configured so as not to share SRLG information with the client network, the SRLG sub-object is not inserted in the RESV message even if the SRLG information flag was set in the received PATH message. Note that the SRLG information is expected to be always up-to-date.

Establishment of a new LSP with SRLG diversity constraints:

When a dual-homed CE device sends an LSP setup requests to a PE device for a new LSP that is required to be SRLG diverse with respect to an existing LSP that is entering the network via another PE device, the CE device sets the SRLG diversity flag (note: IANA to assign the new SRLG diversity flag) in the LSP attributes sub-object of the PATH message that initiates the setup of this new LSP. When the PE device receives this request it calculates a path to the given destination and uses the received SRLG information as path computation constraints.

[4.1.1.2](#). Error Handling Procedures

When the CE device receives a RSVP PATH message with the SRLG information flag set and if the provider's network policy does not permit sharing of SRLG information, the PE device shall notify the CE device by sending a RSVP PathErr with a Notify error code (error code to be defined) "Retrieval of SRLG information not permitted". As described above, the PE device must not include the SRLG sub-object with the SRLG information for the LSP in the RSVP RESV message.

If the PE device receives a RSVP PATH message for a new LSP with the SRLG diversity flag set and SRLG information in the SRLG sub-object, the PE device tries to calculate a route to the given destination that is SRLG diverse with respect to the provided SRLG information. If no route can be found, a RSVP PathErr message with an error code (error code to be defined) "No SRLG diverse route available toward destination".

If the PE device receives a RSVP PATH message for a new LSP with the SRLG diversity flag set and SRLG information in the SRLG sub-object and if the PE device does not support the SRLG sub-object, the PE device shall send a PathErr message to the CE device, indicating an "Unknown object class".

Further error handling cases will be added in the next revision of

this document.

[4.1.2](#). Using Path Affinity Set Extension

The Path Affinity Set (PAS) is used to signal diversity in a pure CE context by abstracting SRLG information. There are two types of diversity information in the PAS. The first type of information is a single PAS identifier. The Second part is the optional PATH information, in the form of Source and Destination addresses of an exclude path or set of paths that MAY be specified. The motive behind the PAS information is to have as little exchange of diversity information as possible between the VPN CE and PE elements.

Rather than a detailed CE or PE SRLG list, the Path Affinity Set contains an abstract SRLG identifier that associates the given path as diverse. Logically the identifier is in a VPN context and therefore only unique with respect to a particular VPN.

How the CE determines the PAS identifier is a local matter for the CE administrator. A CE may signal the PAS identifier as a diversity object in the PATH message. This identifier is a suggested identifier and may be overridden by a PE under some conditions.

For example, a PAS identifier can be used with no prior exchange of PAS information between the CE and the PE. Upon reception of the PAS identifier information the PE can infer the CE's requirements. The actual PAS identifier used will be returned in the RESV message. Optionally an empty PAS identifier allows the PE to pick the PAS identifier.

Similar to the [section 4.1.1](#) on SRLG information, a PE can return PAS identifier as the response to a Query allowing flexibility.

A PE interprets the specific PAS identifier, for example, "123" as meaning to exclude the PE SRLG information (or equivalent) that has been allocated by LSPs associated with this Path Affinity Set identifier "123", for any LSPs associated with the resources assigned

to the VPN. For example, if a Path exists for the LSP with the identifier "123", the PE would use local knowledge of the PE SRLGs associated with the "123" LSPs and exclude those SRLGs in the path request. In other words, two LSPs that need to be diverse both signal "123" and the PEs interpret this as meaning not to use shared resources. Alternatively, a PE could use the PAS identifier to select from already established LSPs. Once the path is established it becomes the "123" identifier or optionally another PAS identifier for that VPN that replaces "123".

The optional PAS Source and Destination Address tuple represents one or more source addresses and destination addresses associated with the CE Path Affinity Set identifier. These associated address tuples represent paths that use resources that should be excluded for the establishment of the current LSP. The address tuple information gives both finer grain details on the path diversity request and serves as an alternative identifier in the case when the PAS identifier is not known by the PE. The address tuples used in signaling is within a CE context and its interpretation is local to a PE that receives a Path request from a CE. The PE can use the address information to relate to PE Addresses and PE SRLG information. When a PE satisfies a connection setup for a (SRLG) diverse signaled path, the PE may optionally record the PE SRLG information for that connection in terms of PE based parameters and associate that with the CE addresses in the Path message.

Specifically for L1VPNs, Port Information table (PIT) [[RFC5251](#)] can be leveraged to translate between CE based addresses and PE based addresses. The Path Affinity Set and associated PE addresses with PE SRLG information can be distributed via the IGP in the provider transport network (or by other means such as configuration); they can be utilized by other PEs when other CE Paths are setup that would require path/connection diversity. This information is distributed on a VPN basis and contains a PAS identifier, PE addresses and SRLG information.

If diversity is not signaled, the assumption is that no diversity is required and the Provider network is free to route the LSP to optimize traffic. No Path affinity set information needs to be recorded for these LSPs. If a diversity object is included in the connection request, the PE in the Provider Network should be able to look-up the existing Provider SRLG information from the provider

1. The Address Length field (8 bits) is the number of bytes for both the source address and destination address. The address may be in any format from 1 to 32 bytes but the key point is the customers can maintain their existing addresses. A value of zero indicates there are no addresses included.
2. The Number of Path Affinity (8 bits) sets is included in the object. This is typically 1. Addition of other sets is for further study.
3. The Path affinity Set identifier (4 bytes) is a single number that represents a summarized SRLG for this path. Paths with that same Path Affinity set should be set up with diverse paths and associated with the path affinity set. A value of all zeros allows the PE to pick a PAS identifier to return. A PAS identifier of an established path may be different than the requested path identifier.
4. The diversity Bit (D) (one Bit) indicates if the diversity must be satisfied when set as a one. If a PE finds an established path with a Path Affinity set matching the signaled Path Affinity Set or the signaled Address tuple it should attempt find a diverse path.

5. The Diverse Path Source address/destination address tuple is that of an established LSP in the PE network that belongs to the same Path Affinity Set identifier. If the path for these addresses is not established or cannot be determined by the PE edge processing the PATH request then the path is established only with the Path Affinity identifier. If the path(s) for these address tuples are known by the PE the PE uses the SRLG information associated with these addresses. If in any case a diverse path cannot be setup then the Diverse bit controls whether a path is established anyway. The PE must use the PIT to translate CE Addresses into provider addresses when correlating with provider SRLG information. How SRLG information and network address tuples are distributed is for future study.

[4.1.2.1](#). Operational Procedures

When a CE constructs a PATH message it may optionally specify and

insert a Path Affinity Set in the PATH message. This Path Affinity Set may optionally include the address of an LSP that that could belong to the same Path Affinity Set. The Path Affinity Set identifier is a value (0 through 2**32-255) that is independent of the mechanism the CE or the PE use for diversity. The Path Affinity Set is a single identifier that can be used to request diversity and associate diversity.

When processing a CE PATH message in a VPN Overlay, the PE first looks up the PE based addresses in the Provider Index Table (PIT). If the Path Affinity Set is included in the PATH message, the PE must look up the SRLG information (or equivalent) in the PE network that has been allocated by LSPs associated with a Path Affinity Set and exclude those resources from the path computation for this LSP if it is a new path. The PE may alternatively choose from an existing path with a disjoint set of resources. If a path that is disjoint cannot be found, the value of the PAS diversity bit determines whether a path should be setup anyway. If the PAS diversity bit is clear, one can still attempt to setup the LSP. A PE should still attempt to minimize shared resources but that is an implementation issue, and is outside the scope of this document.

Optionally the CE may use a value of all zeros in the PAS identifier allowing the PE to select an appropriate PAS identifier. Also the PE may to override the PAS identifier allowing the PE to re-assign the identifier if required. A CE should not assume that the PAS identifier used for setup is the actual PAS identifier.

[4.1.2.2](#). Error Handling Procedures

The PAS object must be understood by the PE device. Otherwise, the CE should not use the PAS object. Path Message processing of the PAS object SHOULD follow CTYPE 0. An Error code of IANA (TBD) indicates that the PAS object is not understood.

When a PAS identifier is not recognized by a PE it must assume this LSP defines that PAS identifier however the PE may override PAS identifier under certain conditions.

If the identifier is recognized but the Source Address-Destination address pair(s) are not recognized, this LSP must be set up using the

PAS identifier only.

If the identifier is recognized and the Source Address-Destination address pair(s) are also recognized, then the PE SHOULD use the PE SRLG information associated with the LSPs identified by the address pairs to select a disjoint path.

The Following are the additional error codes:

1. Route Blocked by Exclude Route Value IANA (TBA).

4.1.2.3. Distribution of the Path Affinity Set Information

Information about SRLG is already available in the IGP TE database. A PE network can be designed to have additional opaque records for Provider paths that distribute PE paths and SRLG on a VPN basis. When a PE path is setup, the following information allows a PE to lookup the PE diversity information:

- o L1 VPN Identifier 8 bytes
- o Path Affinity Set Identifier
- o Source PE Address
- o Destination PE Address
- o List of PE SRLG (variable)

The source PE address and destination PE address are the same addresses in the VPN PIT and correspond to the respective CE address identifiers.

Note that all of the information is local to the PE context and is not shared with the CE. The VPN Identifier is associated with a CE. The only value that is signaled from the CE is the Path Affinity Set and optionally the addresses of an existing LSP. The PE stores source

and destination PE addresses of the LSP in their native format along with the SRLG information. This information is internal to the PE network and is always known.

PE paths may be setup on demand or they may be pre-established. When paths are pre-established, the Path Affinity Set is set to unassigned 0x0000 and is ignored. When a CE uses a pre-established path the PE may set the Path SRLG Path Affinity Set value if the CE signals one otherwise the Path Affinity Set remains unassigned 0x0000.

5. Latency Signaling Extensions

Some network applications are sensitive to latency (sometimes also called delay) while other applications are sensitive to latency variation (sometimes also called delay variation). Specifically, real time applications typically do have certain latency requirements. It shall be noted that latency variation is typically not an issue for TDM networks including the WDM layer. For these technologies the latency is constant and there is no latency variation added. Latency variation is typically caused in packet networks or when packet based services are encapsulated into a constant bit rate server layer signal, which requires buffering of the arriving packets that may arrive in bursts. An example is an Ethernet VLAN service that is mapped into a constant bit rate server layer such as an ODUK or ODUFlex OTN signal.

The GMPLS UNI as defined in [[RFC4208](#)] does not support latency as a signaling parameter that would allow a CE device to signal to the PE device that latency and/or latency variation constraints need to be met when a path is calculated for the requested LSP. The path computation function does typically calculate a route to the given destination that has the least TE metric (least cost routing). However, if a CE device requests an LSP via the UNI interface for an application that is sensitive to latency/latency variation, it should be possible to signal to the PE device that the objective function should rather take latency into account instead of the TE metric.

In order to support latency/latency variation as path computation constraint, the network has to support latency/latency variation as TE metric extension as defined in [DRAFT OSPF TE METRIC EXT] - note that [DRAFT OSPF TE METRIC EXT] is using the terms delay/delay variation instead of latency/latency variation.

A latency requirement can be added to signaling in the form of a

constraint [DRAFT OBJECTIVE FUNCTION]. The constraint can take the form of:

- o Minimal latency
- o Maximum acceptable latency (upper bound)
- o Minimal latency variation
- o Maximum acceptable latency variation (upper bound), if applicable

While some systems may be able to compute routes based on delay metrics it is usual that minimizing the accumulated TE link metric (link cost) or the number of hops subject to bandwidth reservation are satisfied as the object function and delay is not considered. When considering diversity latency falls after diversity constraints have been satisfied.

Recording the latency of existing paths [DRAFT_TE_METRIC RECORD] to ensure they meet a maximum acceptable latency can be utilized to ensure latency constraint is met.

When a low latency path is required, the minimize latency subject to other constraints criteria should be signaled. A CE device can use the recorded latency to ensure that the maximum acceptable latency has been met.

[5.1.](#) RSVP-TE Extensions

At the UNI, the RSVP-TE extensions as defined in [DRAFT OBJECTIVE FUNCTION] SHALL be used for signaling the PE device whether a path with minimal latency is requested or whether certain latency/latency variation upper bound constraints shall be met for the end-to-end connection, i.e., from the source CE device to the destination CE device. The following objective function (OF) code point SHALL be used in the OF sub-object of the ERO to indicate that latency/latency variation constraints SHALL be taken into account when the path computation function that is invoked by the PE node that expands the route from the PE device to the destination CE device:

- o OF code value 8 (to be assigned by IANA) is for the Minimum Latency Path (MLP) OF
- o OF code value 9 (to be assigned by IANA) is for Minimum Latency Variation Path (MLVP) OF

Additionally, an optional OF metric-bound sub-object MAY be carried

within an ERO object of the RSVP-TE Path message. The two metric-

bound sub-objects defined in [DRAFT OBJECTIVE FUNCTION] that are corresponding to the two OFs above are:

- o metric bound sub-object of Type T=4: Cumulative Latency
- o metric bound sub-object of Type T=5: Cumulative Latency Variation

The metric-bound indicates an upper bound for the path metric that MUST NOT be exceeded for the ERO expending node to consider the computed path as acceptable. It shall be noted that the metric bound included in the RSVP-TE Path message at the UNI has end-to-end significance, which means that the upper bound metric constraint MUST be met for the path from the source CE device to the destination CE device.

[5.2.](#) Operational Procedures

The processing rules as defined in [DRAFT OBJECTIVE FUNCTION] for the OF sub-object and the optional OF metric-bound sub-object SHALL be applied at the ingress PE device when the source CE device requests an LSP (It shall be noted that [DRAFT OBJECTIVE FUNCTION] has a wider scope and may also apply to inter-domain interfaces, i.e., when the provider network is composed of multiple separate domains.).

[5.3.](#) Error Handling Procedures

The error handling rules as defined in [DRAFT OBJECTIVE FUNCTION] for the OF sub-object and the optional OF metric-bound sub-object SHALL be applied.

[6.](#) Security Considerations

Security for L1VPNs is covered in [[RFC4847](#)], [[RFC5251](#)] and [[RFC5253](#)]. In this document, the model follows a generic GMPLS VPN based on the L1VPN control plane model where CE addresses are completely distinct from the PE addresses.

The use of a private network assumes that entities outside the

network cannot spoof or modify control plane communications between CE and PE. Furthermore, all entities in the private network are assumed to be trusted. Thus, no security mechanisms are required by the protocol exchanges described in this document.

However, an operator that is concerned about the security of their private control plane network may use the authentication and

integrity functions available in RSVP-TE [[RFC3473](#)] or utilize IPsec ([[RFC4301](#)], [[RFC4302](#)], [[RFC4835](#)], [[RFC5996](#)], and [[RFC6071](#)]) for the point-to-point signaling between PE and CE. See [[RFC5920](#)] for a full discussion of the security options available for the GMPLS control plane.

[7](#). IANA Considerations

TBD

[8](#). References

[8.1](#). Normative References

- [RFC2119] Bradner, S., "Key words for use in RFCs to Indicate Requirement Levels", [BCP 14](#), [RFC 2119](#), March 1997.
- [RFC4202] Kompella, K., Rekhter, Y., "Routing Extensions in Support of Generalized Multi-Protocol Label Switching (GMPLS)", [RFC 4202](#), October 2005.
- [RFC4208] Swallow, G., Drake, J., Ishimatsu, H., and Y. Rekhter, "Generalized Multiprotocol Label Switching (GMPLS) User-Network Interface (UNI): Resource ReserVation Protocol-Traffic Engineering (RSVP-TE) Support for the Overlay Model", [RFC 4208](#), October 2005.

[RFC5251] Fedyk, D., Rekhter, Y., Editors "Layer 1 VPN Basic Mode", [RFC 5251](#), July 2008.

[SRLG_info] Zhang, F., Li, D., Gonzalez de Dios, O., Margaria, C., Hartley, M., "RSVP-TE Extensions for Collecting SRLG Information", [draft-ietf-ccamp-rsvp-te-srlg-collect-02.txt](#), February 2013.

[DRAFT OBJECTIVE FUNCTION] Ali, Z., Swallow, G., Filsfils, C., Fang, L., Kumaki, K., Kunze, R., "Resource ReserVation Protocol - Traffic Engineering (RSVP-TE) extension for signaling Objective Function and Metric Bound", [draft-ali-ccamp-rc-](#)

Fedyk et al.

Expires January 2014

[Page 18]

Internet-Draft

[draft-fedyk-ccamp-uni-extensions](#)

July 2013

[objective-function-metric-bound-02.txt](#), July 2012.

[8.2](#). Informative References

[RFC4026] Andersson, L. and T. Madsen, "Provider Provisioned Virtual Private Network (VPN) Terminology", [RFC 4026](#), March 2005.

[RFC6071] Frankel, S. and S. Krishnan, "IP Security (IPsec) and Internet Key Exchange (IKE) Document Roadmap", [RFC 6071](#), February 2011.

[RFC3473] Berger, L. (editor), "Generalized MPLS Signaling - RSVP-TE Extensions", [RFC 3473](#), January 2003.

[RFC4301] Kent, S. and K. Seo, "Security Architecture for the Internet Protocol", [RFC 4301](#), December 2005.

[RFC4302] Kent, S., "IP Authentication Header", [RFC 4302](#), December 2005.

- [RFC5996] Kaufman, C., Hoffman, P., Nir, Y., and P. Eronen, "Internet Key Exchange Protocol Version 2 (IKEv2)", [RFC 5996](#), September 2010.
- [RFC4835] Manral, V., "Cryptographic Algorithm Implementation Requirements for Encapsulating Security Payload (ESP) and Authentication Header (AH)", [RFC 4835](#), April 2007.
- [RFC4847] Takeda, T., Editor "Framework and Requirements for Layer Virtual Private Networks", [RFC 4847](#), April 2007.
- [RFC5253] Takeda, T., Ed., "Applicability Statement for Layer 1 Virtual Private Network (L1VPN) Basic Mode", [RFC 5253](#), July 2008.
- [RFC5920] Fang, L., Ed., "Security Framework for MPLS and GMPLS Networks", [RFC 5920](#), July 2010.

Fedyk et al.

Expires January 2014

[Page 19]

Internet-Draft

[draft-fedyk-ccamp-uni-extensions](#)

July 2013

[DRAFT_TE_METRIC RECORD] Ali, Z., Swallow, G., Filsfils, C., Hartley, M., Kumaki, K., Kunze, R., "Resource ReserVation Protocol-Traffic Engineering (RSVP-TE) extension for recording TE Metric of a Label Switched Path", [draft-ietf-ccamp-te-metric-recording-02.txt](#), July 2013.

[DRAFT_OSPF TE METRIC EXT] Giacalone, S., Ward, D., Drake, J., Atlas, A., Previdi, S., "OSPF Traffic Engineering (TE) Metric Extensions", [draft-ietf-ospf-te-metric-extensions-04.txt](#), June 2013.

Copyright (c) 2013 IETF Trust and the persons identified as authors of the code. All rights reserved.

Redistribution and use in source and binary forms, with or without

modification, is permitted pursuant to, and subject to the license terms contained in, the Simplified BSD License set forth in [Section 4.c](#) of the IETF Trust's Legal Provisions Relating to IETF Documents (<http://trustee.ietf.org/license-info>).

Authors' Addresses

Don Fedyk
Alcatel-Lucent
Groton, MA, 01450
Email: donald.fedyk@alcatel-lucent.com

Dieter Beller
Alcatel-Lucent
Email: Dieter.Beller@alcatel-lucent.com

Lieven Levrau
Alcatel-Lucent
Email: Lieven.Levrau@alcatel-lucent.com

Daniele Ceccarelli
Ericsson
Email: Daniele.Ceccarelli@ericsson.com

Fatai Zhang
Huawei Technologies
Email: zhangfatai@huawei.com

Fedyk et al.

Expires January 2014

[Page 20]

Internet-Draft

[draft-fedyk-ccamp-uni-extensions](#)

July 2013

Yuji Tochio
Fujitsu
Email: tochio@jp.fujitsu.com

Xihua Fu
ZTE
Email: fu.xihua@zte.com.cn

