

Workgroup: TEAS Working Group
Internet-Draft:
draft-gcdrb-teas-5g-network-slice-
application-02

Published: 8 March 2023

Intended Status: Informational

Expires: 9 September 2023

Authors: X. Geng L. Contreras R. Rokui
 Huawei Technologies Telefonica Ciena
 J. Dong I. Bykov
 Huawei Technologies Ribbon Communications

IETF Network Slice Application in 3GPP 5G End-to-End Network Slice

Abstract

Network Slicing is one of the core features in 5G, which provides different network service as independent logical networks. To provide 5G network slices service, an end-to-end network slice needs to consists of 3 major types of network segments: Radio Access Network (RAN), Mobile Core Network (CN) and Transport Network (TN). This document describes the application of IETF network slice in providing 5G end-to-end network slices, including the network slice identification mapping, network slice parameter mapping and 5G IETF Network Slice NBI.

Requirements Language

The key words "MUST", "MUST NOT", "REQUIRED", "SHALL", "SHALL NOT", "SHOULD", "SHOULD NOT", "RECOMMENDED", "MAY", and "OPTIONAL" in this document are to be interpreted as described in [RFC 2119](#) [[RFC2119](#)].

Status of This Memo

This Internet-Draft is submitted in full conformance with the provisions of BCP 78 and BCP 79.

Internet-Drafts are working documents of the Internet Engineering Task Force (IETF). Note that other groups may also distribute working documents as Internet-Drafts. The list of current Internet-Drafts is at <https://datatracker.ietf.org/drafts/current/>.

Internet-Drafts are draft documents valid for a maximum of six months and may be updated, replaced, or obsoleted by other documents at any time. It is inappropriate to use Internet-Drafts as reference material or to cite them other than as "work in progress."

This Internet-Draft will expire on 9 September 2023.

Copyright Notice

Copyright (c) 2023 IETF Trust and the persons identified as the document authors. All rights reserved.

This document is subject to BCP 78 and the IETF Trust's Legal Provisions Relating to IETF Documents (<https://trustee.ietf.org/license-info>) in effect on the date of publication of this document. Please review these documents carefully, as they describe your rights and restrictions with respect to this document. Code Components extracted from this document must include Revised BSD License text as described in Section 4.e of the Trust Legal Provisions and are provided without warranty as described in the Revised BSD License.

Table of Contents

- [1. Introduction](#)
- [2. Terminologies](#)
- [3. 5G End-to-End Network Slice](#)
 - [3.1. IETF Network Slices in Distributed RAN deployment](#)
 - [3.2. IETF Network Slices in Centralized RAN deployment](#)
 - [3.3. IETF Network Slices in Cloud RAN deployment \(C-RAN\)](#)
 - [3.4. Relationship between IETF network slice and 3GPP network slice](#)
- [4. Overview of the mapping between 3GPP and IETF network slices](#)
 - [4.1. VLAN Hand-off](#)
 - [4.2. SRv6 Label Hand-off](#)
 - [4.3. MPLS Label Hand-off](#)
 - [4.4. Policy based routing \(PBR\)](#)
 - [4.5. GTP Source Port-Based](#)
 - [4.6. Consideration of the Virtual Network Functions \(VNF\)](#)
- [5. 3GPP Network Slice Mapping Parameters](#)
- [6. 5G E2E Network Slice Mapping Procedure](#)
 - [6.1. 5G E2E Network Slice Mapping in Management Plane](#)
 - [6.1.1. Mapping EP transport to IETF NS CE endpoints](#)
 - [6.1.2. Mapping IETF NS CE to PE endpoints](#)
 - [6.2. 5G E2E Network Slice Mapping in Control Plane](#)
 - [6.3. 5G E2E Network Slice Mapping in Data Plane](#)
 - [6.3.1. Data Plane Mapping Considerations](#)
 - [6.3.2. Data Plane Mapping Options](#)
- [7. Example of IETF Network Slice request through IETF Network Slice NBI](#)
- [8. Gap Analysis](#)
- [9. IANA Considerations](#)
- [10. Security Considerations](#)
- [11. Acknowledgements](#)
- [12. Contributors](#)

[13. References](#)

[13.1. Normative References](#)

[13.2. Informative References](#)

[Appendix A. An Appendix](#)

[Authors' Addresses](#)

1. Introduction

Driven by the new applications of 5G, the concept of network slicing is defined to provide a logical network with specific capabilities and characteristics. Network slice contains a set of network functions and allocated resources (e.g. computation, storage and network resources).

The IETF Network Slice (NS) service is defined in [[I-D.ietf-teas-ietf-network-slices](#)] as a set of connections between a number of CEs, with that connections having specific Service Level Objectives (SLOs) and Service Level Expectations (SLEs) over a common underlay network, with the traffic of one customer being separated from another. The concept of IETF network slice is conceived as technology agnostic.

The IETF NS service is specified in terms of the set of endpoints (from CE perspective) connected to the slice, the type of connectivity among them, and a set of SLOs and SLEs for each connectivity construct.

In [[I-D.ietf-teas-ietf-network-slice-nbi-yang](#)], the endpoints are described by an identifier, with some metrics associated to the connections among them as well as certain policies (e.g., rate limits for incoming and outgoing traffic).

The 5G network slice as defined in [3GPP TS 23.501] does not take the transport network slice into consideration. This document introduces the concept of 5G end-to-end network slice, which is composed of three major types network segments: Radio Access Network (RAN), Transport Network (TN) and Mobile Core Network (CN). Transport network is supposed to provide the required connectivity between AN and CN or inside AN/CN, with specific performance commitment. For each end-to-end network slice, the topology and performance requirement for transport network can be very different, which requests transport network to have the capability of supporting multiple different transport network slices.

This document addresses the request of IETF Network Slice services for 3GPP 5G Network Slices. The realization of such requested slices is out of the scope of this document and addressed in other documents such as [[I-D.srld-teas-5g-slicing](#)].

2. Terminologies

The key words "MUST", "MUST NOT", "REQUIRED", "SHALL", "SHALL NOT", "SHOULD", "SHOULD NOT", "RECOMMENDED", "MAY", and "OPTIONAL" in this document are to be interpreted as described in [RFC2119].

Terminologies for IETF Network Slice go along with the definition in [[I-D.ietf-teas-ietf-network-slices](#)].

The following terms are used in this document:

NSC: IETF Network Slice Controller

NSI: Network Slice Instance

NSSI: Network Slice Subnet Instance

S-NSSAI: Single Network Slice Selection Assistance Information

RAN: Radio Access Network

TN: Transport Network

CN: Mobile Core Network

DSCP: Differentiated Services Code Point

CSMF: Communication Service Management Function

NSMF: Network Slice Management Function

NSSMF: Network Slice Subnet Management Function

IOC: Information Object Class model, defined in 3GPP

3. 5G End-to-End Network Slice

The scope of 5G End-to-End Network Slice discussed in this document is shown in [Figure 1](#). Transport network provides connectivity between and inside RAN and CN. To support fully automated enablement an assurance of 5G E2E network slices, multiple controllers are needed to manage 5G E2E network slices in RAN, Core and Transport domains. In addition, an E2E network slice orchestrator is needed to provide coordination and control of network slices from an E2E perspective.

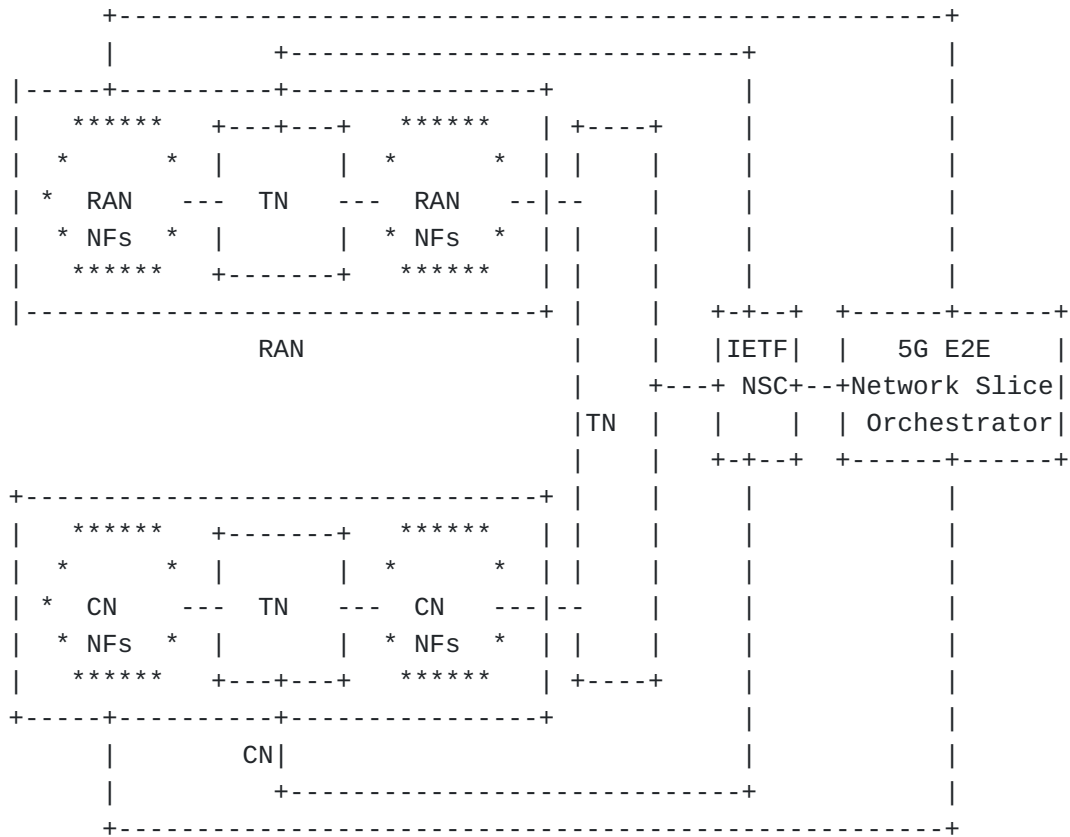

Figure 1: Scope of 5G End to End Network Slice

Depends on Radio Access Network (RAN) deployment, one or multiple IETF network slice might be needed in 3GPP network. In the details of various IETF network slices for following RAN deployment will be discussed:

- *Distributed RAN
- *Centralized RAN
- *Cloud RAN (C-RAN)

3.1. IETF Network Slices in Distributed RAN deployment

Distributed RAN is the most common deployment of 3GPP RAN networks as shown in [Figure 2](#). The radio access network (RAN) is connected to Core network (CN) using the IETF transport network (TN1).

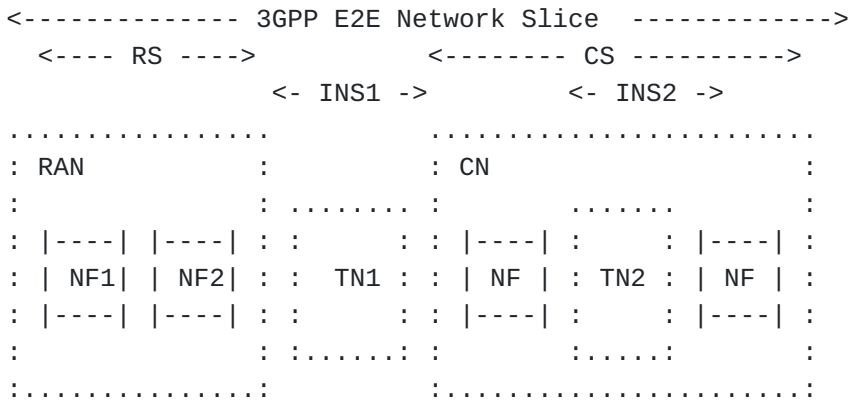

Legend

- INS: IETF Network Slice
- RS: RAN Slice
- CS: Core Slice
- TN: IETF network
- CN: Core Network
- RAN: Access Neetwork (Radio)

Figure 2: IETF network slices in distributed RAN deployment

3.2. IETF Network Slices in Centralized RAN deployment

In general the RAN network consists of network functions NF1 and MF2. NF1 processes the radio signal and is connected to the transport network and NF2 transmits and receives the carrier signal that is transmitted over the air to the end user equipment (UE). In Centralized RAN as depicted in [Figure 3](#), network functions NF1 and NF2 are separated by a network called fronthaul network (FH).

In this deployment a 3GPP E2E network slice contains of RAN and Core slices and IETF network slices INS1, INS2 and INS3. INS1 and INS2 are identical to [Figure 2](#) and INS3 is a new IETF network slice across access network between NF1 and NF2.

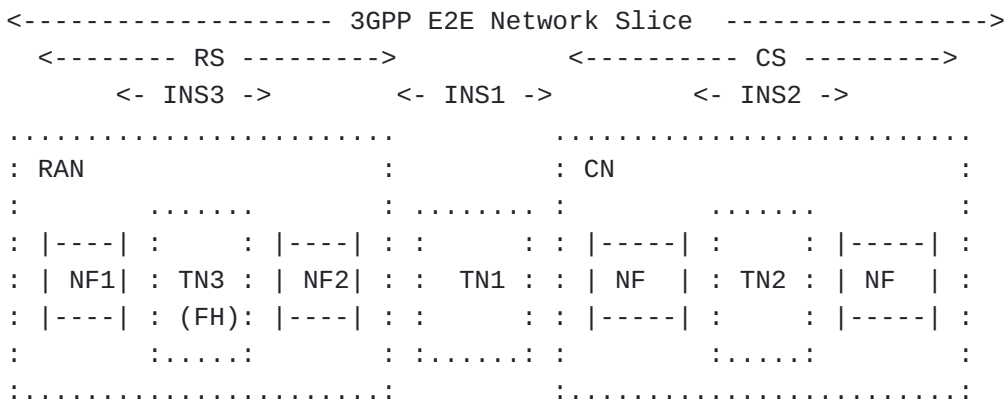

Legend

- INS: IETF Network Slice
- RS: RAN Slice
- CS: Core Slice
- FN: Fronthaul IETF network
- TN: IETF network
- CN: Core Network
- RAN: Access Network (Radio)

Figure 3: IETF network slices in centralized RAN deployment

3.3. IETF Network Slices in Cloud RAN deployment (C-RAN)

In Cloud RAN deployment, the network function NF2 is further disaggregated into real-time and non-real-time components. As shown in [Figure 4](#), these disaggregated components are called CU (Central Unit) and DU (Distributed Unit) where they are connected by a new network called Midhaul network (MH).

In this deployment a single 3GPP E2E network slice contains not only RAN and 5G Core slices but IETF network slices INS1, INS2, INS3 and INS4. IETF network slices INS1, INS2 and INS3 are identical to their counterparts in centralized RAN deployment case (Refer to [Figure 3](#)). In this deployment a new IETF network slice INS4 connects the DUs to CUs through F1 interfaces.

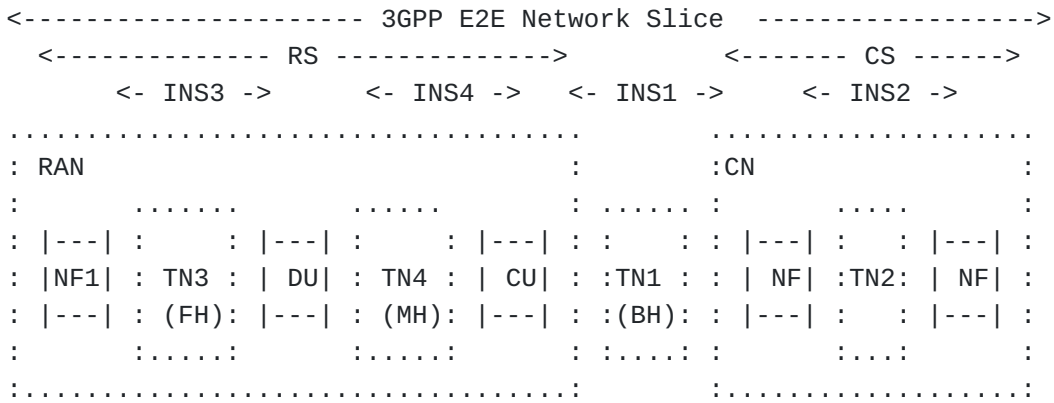

Legend

- INS: IETF Network Slice
- RS: RAN Slice
- CS: Core Slice
- FN: Fronthaul IETF network
- MN: Midhaul IETF bnetwork
- BH: Backhual IETF network
- TN: IETF network
- DU: Distributed Unit
- CU: Central Unit
- CN: Core Network
- RAN:Access Neetwork (Radio)

Figure 4: IETF network slices in cloud RAN deployment (C-RAN)

3.4. Relationship between IETF network slice and 3GPP network slice

For the sake of description, the descriptions below all take the TN slice between RAN and CN as an example, and the other cases are similar. [Figure 5](#) shows the correspondence between network entities in E2E 5G slices and IETF slices respectively

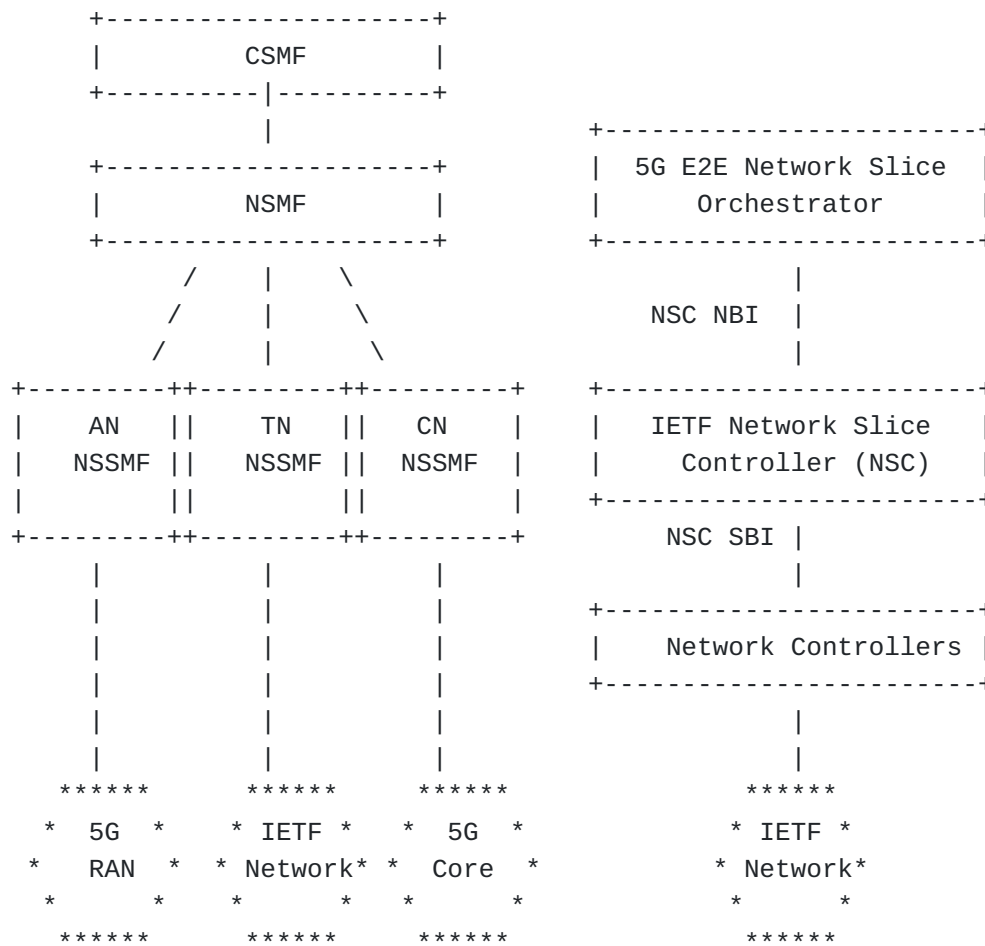

Legend

Figure 5: Relationship between 3GPP domain controllers and IETF Network Slice Controller

An example of 5G E2E Network Slice is showed in [Figure 6](#). Each e2e network slice contains AN slice, CN slice and one or more IETF network Slices. 3GPP identifies each e2e network slice using an integer called S-NSSAI. In Figure 4 there are three instances of e2e network slices which are identified by S-NSSAI 01111111, 02222222 and 02333333, respectively. Each instance of e2e network slice contains AN slice, CN Slice and one or more IETF network slices. For example, e2e network slice 01111111 has AN Slice instance 4, CN Slice instance 1 and IETF network slice 6. Note that 3GPP does not cover the IETF network slice. See [\[I-D.ietf-teas-ietf-network-slices\]](#) for details of IETF network slice.

Note that 3GPP uses the terms NSI and NSSI which are a set of network function and required resources (e.g. compute, storage and

networking resources) which corresponds to network slice Instance, whereas S-NSSAI is an integer that identifies the e2e network slice.

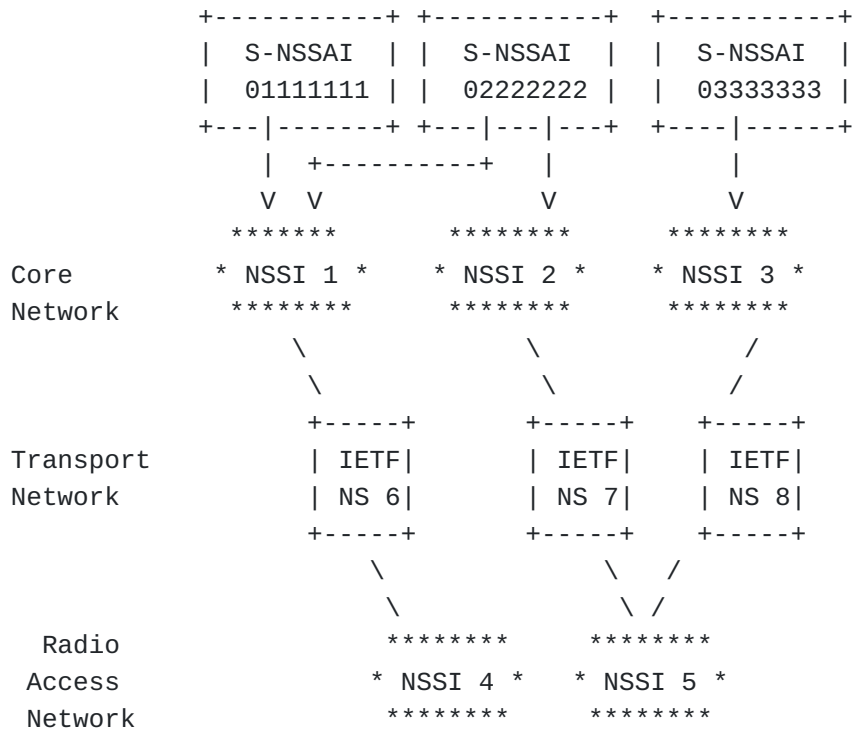

Legend

Figure 6: 5G End-to-End Network Slice and its components

The following network slice related identifiers in management plane, control plane and data(user) plane play an important role in end-to-end network slice mapping:

*Single Network Slice Selection Assistance Information(S-NSSAI):
The end-to-end network slice identifier, which is defined in [TS23501]; S-NSSAI is used during 3GPP network slice signalling process.

*IETF Network Slice Identifier: An identifier allocated by IETF Network Slice Controller (NSC) in management plane. In data plane, IETF Network Slice Identifier may be instantiated with existing data plane identifiers and doesn't necessarily require new encapsulation.

*IETF Network Slice Interworking Identifier: Data-plane network slice identifier which is used for mapping the end-to-end network slice traffic to specific IETF network slice. The IETF Network Slice Interworking Identifier is a new concept introduced by this

draft, which may be instantiated with existing data plane identifiers and doesn't necessarily require new encapsulation.

Note: the term "IETF Network Slice Interworking Identifier" is proposed but requires further discussion.

4. Overview of the mapping between 3GPP and IETF network slices

Referring to Figure 2-1, 2-2 and 2-3, a 3GPP network slice might have one or more IETF network slices. [Figure 7](#) is a representation of any of these networks where the IETF network slice provides the connectivity between NF1 and NF2 for specific SLO/SLE. For example, [Figure 7](#) could represent Figure 2-3 where the IETF network slice needed between network functions are CU and UPF or it could represent the Figure 2-3 where the IETF network slice is between network functions DU and CU.

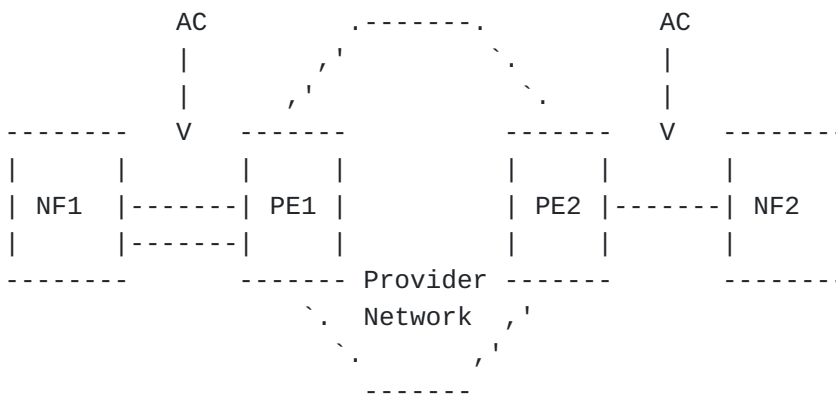
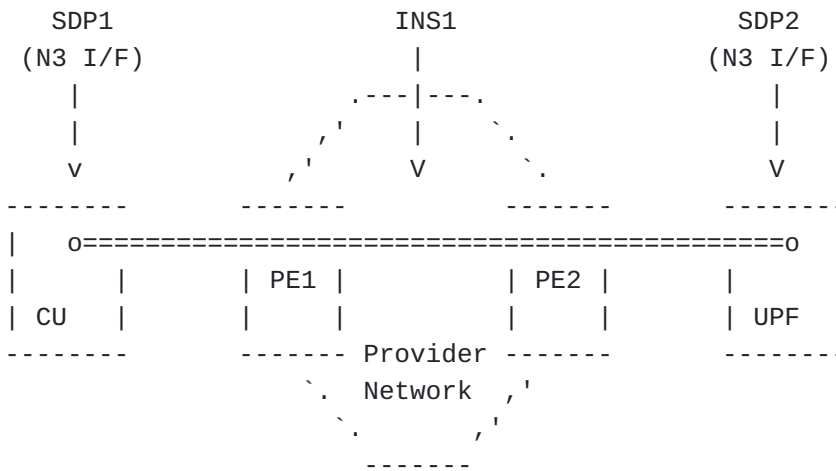
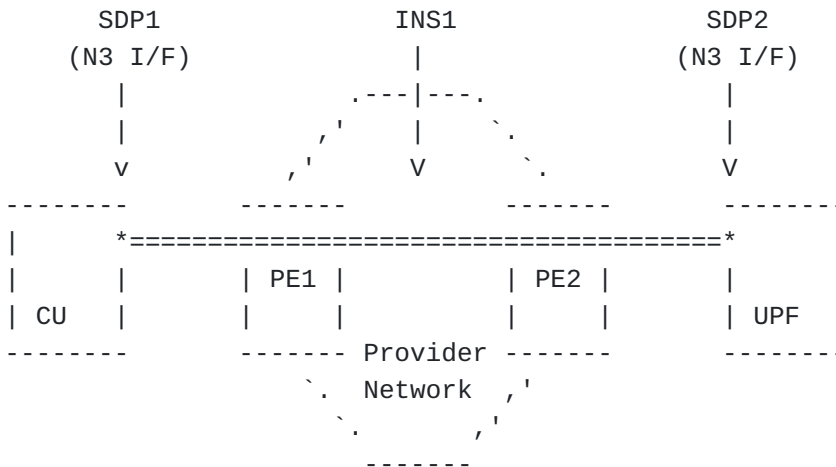

Figure 7: Typical IETF Network Slice in 3GPP Network

To provide an overview of various IETF network slice realization solutions, we focus on Figure 2-3 where the IETF network slice is INS1 and NF1 and NF2 are CU and UPF, respectively. [Figure 8](#) shows Although the realization methods described below is related to INS1, they are applicable to other IETF network slices of Figure 2-1, 2-2 and 2-3. The result is shown in Figure 5. Please note that the IETF network slice INS1 is between SDP1 and SPD2 which are the N3 interfaces on CU and UPF, respectively. As shown in [Figure 8\(A\)](#) and [Figure 8\(B\)](#), the SDPs could be the loopback interface or IP interface. For simplicity only case (A) is considered for the rest of the section although the various realization methods are applicable to both cases.



(A)



(B)

Legend:

- * SDP (N3 interface as CU IP interface)
- o SDP (N3 as CU loopback interface)

Figure 8: Representation of a Typical IETF Network Slice in 3GPP Network

To realize the INS1 shown in [Figure 8\(A\)](#), the IETF network slice controller (NSC) can use the following techniques:

- *VLAN handoff
- *MPLS label handoff
- *SRv6 label handoff
- *Policy Based Routing (PBR)

*GTP source port based

4.1. VLAN Hand-off

As shown in [Figure 9](#), the IETF Network slice INS1 is realized between network functions CU and UPF using the VLAN handoff. In this case the VLAN is hand-off ID from the 3GPP network slice to provider network. Refer to section 5 for details of this solution.

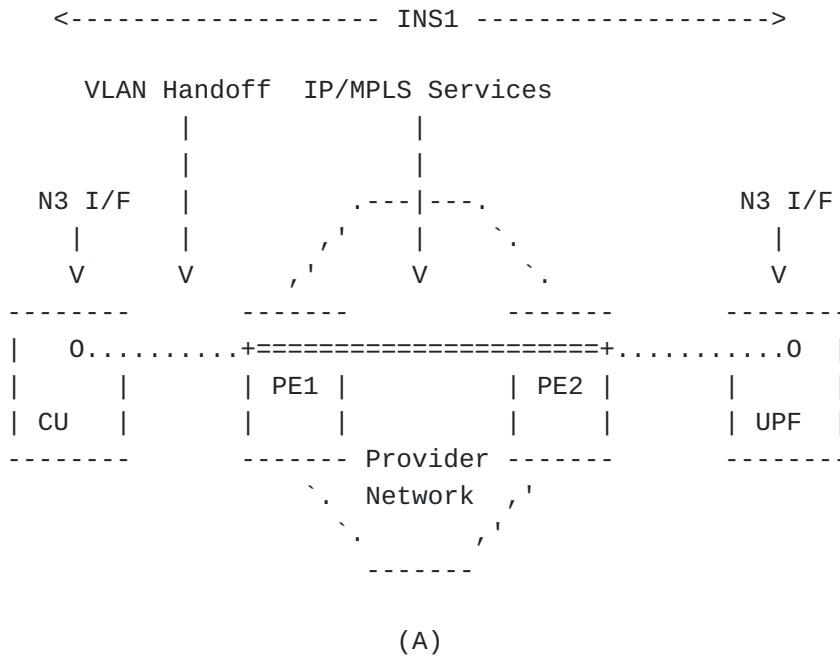

Legend:

- 0 SDP (N3 interface)
- + Access points to provider network
- ... VLAN hand-off
- === IP/MPLS transport service in provider network

Figure 9: VLAN hand-off based for IETF Network Slice Realization

4.2. SRv6 Label Hand-off

[Figure 10](#) depicts the realization of the IETF network slice INS1 using the SRv6 label handoff method. In this case, an SRv6 label which represents the 3GPP network slice is added by CU or UPF to IP traffic. In this case, network function CU and UPF are the endpoint of the realization of IETF network slice INS1 and PE nodes do not have any context of the IETF network.

In this solution the identification of the 3GPP network slice is embedded into IPv6 label where the 32-bit 3GPP network slice identification is mapped into 128 bit of IPV6 label. In this case

the SRv6 SID is hand-off ID from the 3GPP network slice to provider network. Refer to section 5 for details of this solution.

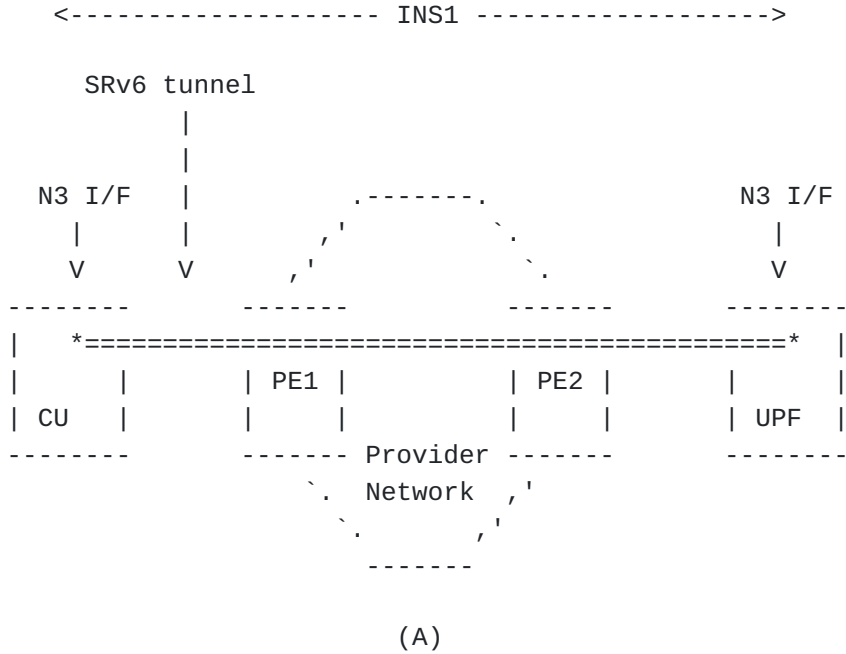

Legend:

* Access points to SRv6 Tunnel. Also the SDP (N3 interface)

=== Realization of the INS1 using SRv6 tunnel

Figure 10: SRv6 hand-off based for IETF Network Slice Realization

4.3. MPLS Lable Hand-off

Similar to section 2.4.2, the MPLS label based method uses an MPLS label as identification of the 3GPP network slice. [Figure 11](#) shows this solution where the IETF network slice INS1 is relalized by CU and UPF using the MPLS label. In this case, network function CU and UPF are the endpoint of the realization of IETF network slice INS1 and PE nodes do not have any context of the IETF network. In this case the MPLS is hand-off ID from the 3GPP network slice to provider network. Refer to section 5 for details of this solution.

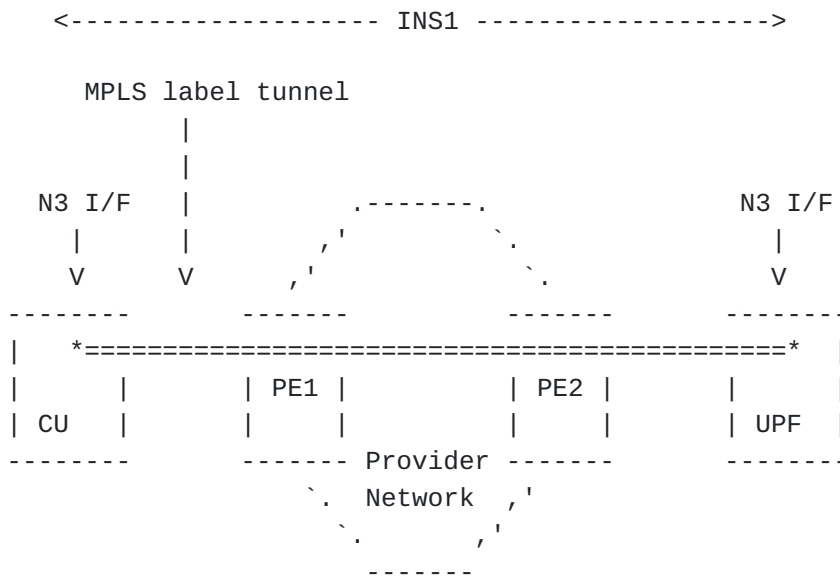

(A)

Legend:

- * Access points to MPLS Tunnel. Also the SDP (N3 interface)
- === Realization of the INS1 using MPLS lable

Figure 11: MPLS hand-off based for IETF Network Slice Realization

4.4. Policy based routing (PBR)

As shown in [Figure 12](#), in some deployments of the 3GPP network slices, it would be possible for provider edge (PE) nodes to infer the 3GPP network slice identification from the information in the IP packet. In these cases, the IETF network slice INS1 is identified by provider edger (PE) routers by a policy which might use any combination of the following attributes of the IP packet.

- *Source N3 IP address
- *Destination N3 IP address
- *Ingress interface
- *DSCP
- *Other information in IP packet

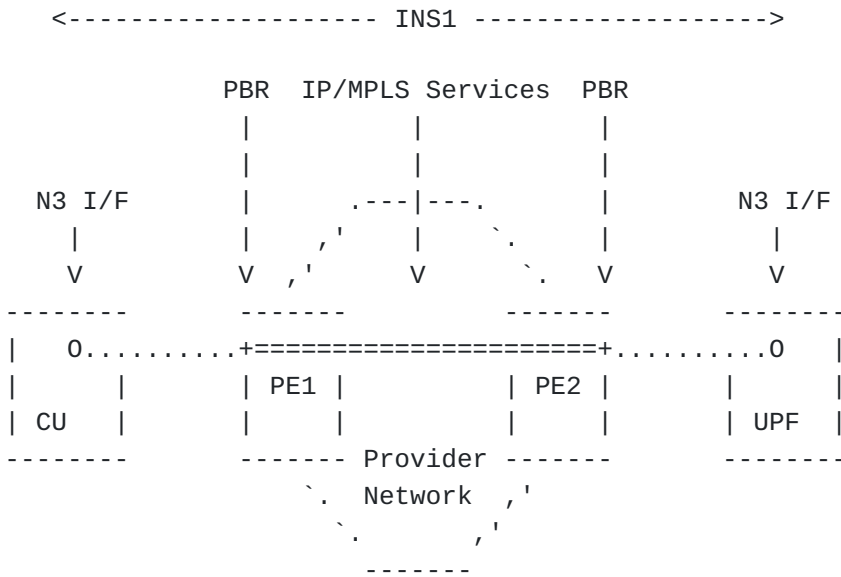

Legend:

- 0 SDP ((N3 interface)
- + Access points of IP/MPLS Services when PBR is applied
- === IP/MPLS service

Figure 12: Policy based routing (PBR) label hand-off based for IETF Network Slice Realization

4.5. GTP Source Port-Based

In some deployments of the 3GPP network slices, the IETF network slice INS1 might be realized by multiple GTP tunnels. As shown in [Figure 13](#), this solution uses the source UDP port of the GTP tunnel to carry the identification of 3GPP network slice. A mapping table between the 3GPP network slice and the source UDP port is needed in this solution and needs to be maintained by network functions CU, UPF and PE nodes. Refer to section 2.5 of [draft-ietf-dmm-tn-aware-mobility-04] for details of this solution.

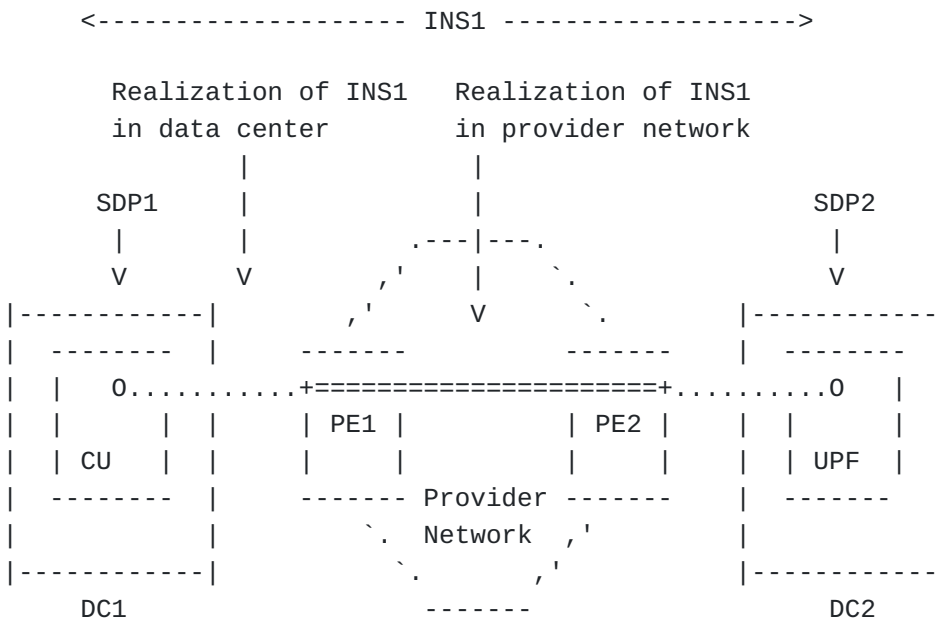

Legend:

- DC Data Center
- O SDP (N3 interfaces)
- === Realization of INS1 in Provider Networks
- ... Realization of INS1 in data centers

Figure 14: VNF Consideration for IETF Network Slice Realization

5. 3GPP Network Slice Mapping Parameters

The network slice concept was introduced in 3GPP specifications from the first 5G release, corresponding to Release 15. As captured in [TS23.501], a network slice represents a logical network providing specific network capabilities and network characteristics.

To make slicing a reality, every technical domain is split into one or more logical network partitions, each referred to as a network slice subnet. The definition of multiple slice subnets on a single domain allows each segment to provide differentiated behaviors, in terms of functionality and/or performance, tailored to some specific needs. The stitching of slice subnets across the RAN, CN and TN results in the definition of 5G network slices in 3GPP.

From a management viewpoint, the concept of network slice subnet represents an independently manageable yet composable portion of a network slice. The rules for the definition of network slice subnets and their composition into network slices are detailed in the 5G Network Resource Model (NRM) [TS28.541], specifically in the Network Slice NRM fragment. This fragment captures the information model of 5G network slicing, which specifies the relationships between different slicing related managed entities, which is represented as

Information Object Class (IOC). The IOC that have been defined including: NetworkSlice IOC, NetworkSliceSubnet IOC, ManagedFunction IOC and EP_Transport IOC.

Information Object Class EP_Transport [TS28.541 Clause 6.3.18] represents logical interface parameters of 3GPP subsystems, providing specific network capabilities and network characteristics. Relationships of Transport slicing-related 3GPP IOCs and IETF domain represented on the Figure X for NgU/N3 slices with traffic between 3GPP CU-UP (or ORAN) CU-UP and 3GPP UPF, while the Figure Y similarly represents F1-U slices with traffic between 3GPP (or ORAN) DU and 3GPP (or ORAN) CU-UP .

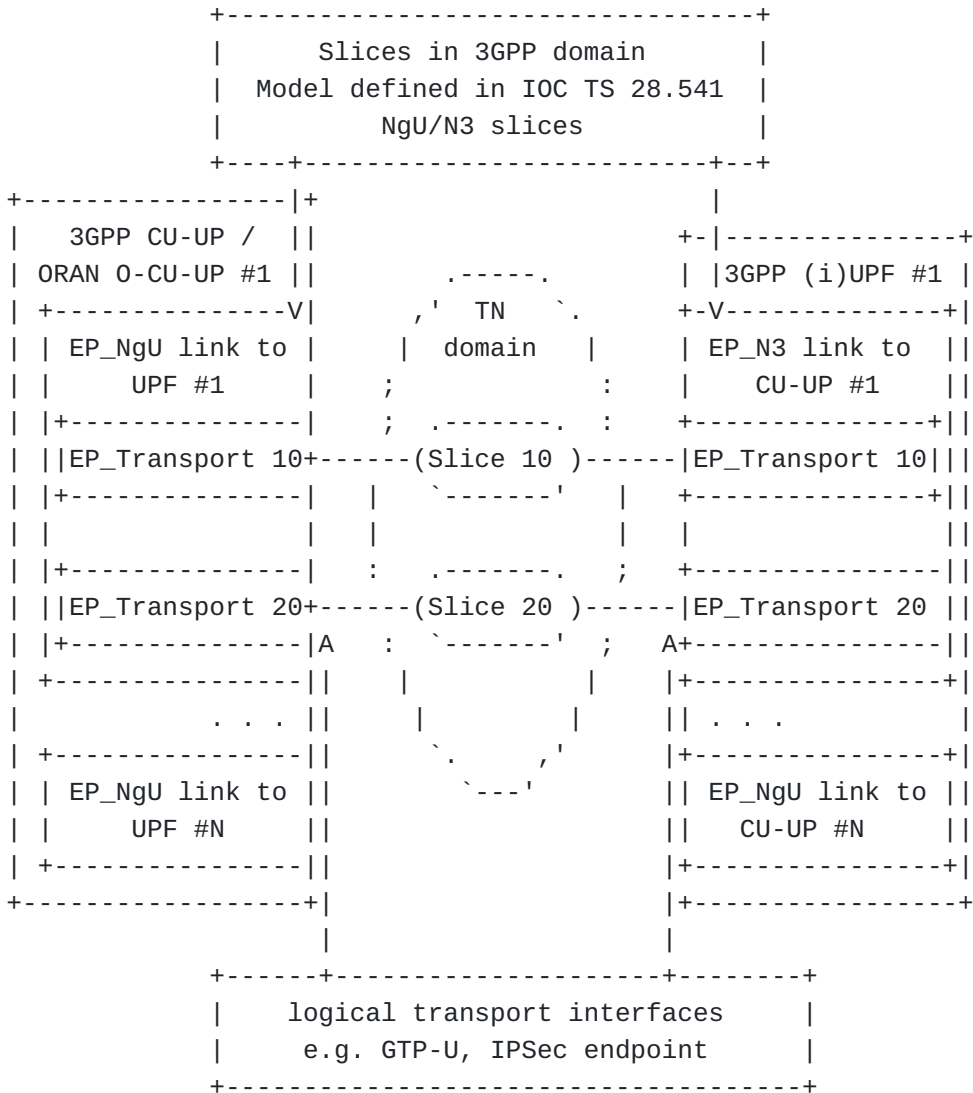

Figure 5-1 Slicing example on the NgU/N3 interface

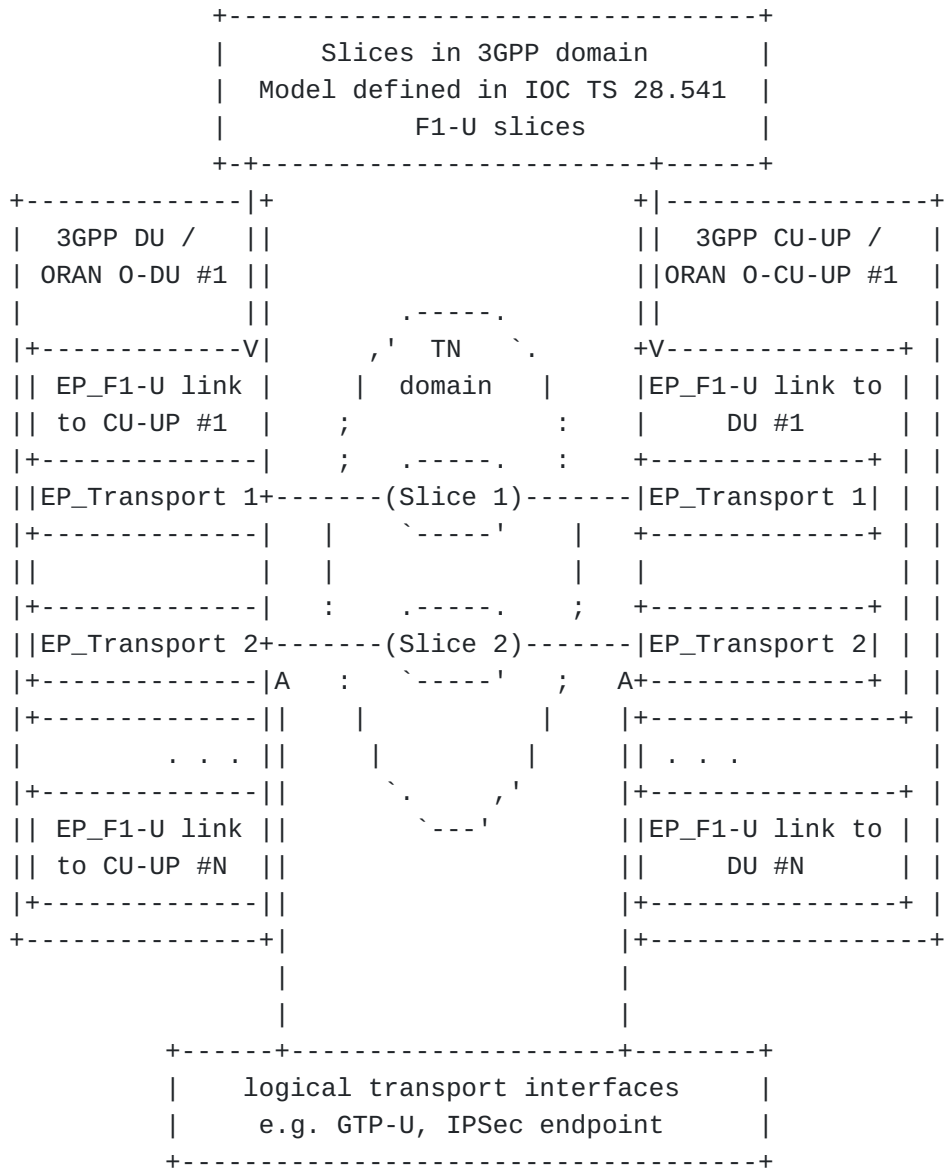

Figure 5-2 Slicing example on the F1-U interface

For the transport (i.e., connectivity) related part of a network slice, the key focus is on the EP_Transport IOC. Instances of this IOC serves to instantiate 3GPP interfaces (e.g., N3) which are needed to support Network Slicing and to define Network Slice transport resources within the 5G NRM. In a nutshell, the EP_Transport IOC permits to define additional logical interfaces for each slice instance of the 3GPP user plane.

According to [TS28.541], the EP_Transport construct on 3GPP side has the following attributes: ipAddress, logicaInterfaceInfo, nextHopInfo, qosProfile and epApplicationRef In which, nextHopInfo could be used for choosing PE node in transport network and LogicalInterfaceInfo could be used for Transport Network Slice mapping.

nextHopInfo (optional): identifies the ingress transport node. Each node can be identified by any combination of IP address of next-hop router of transport network, system name, port name and IP management addresses of transport nodes.

logicInterfaceInfo (mandatory): a set of parameters, which includes logicInterfaceType and logicInterfaceId. It specifies the type and identifier of a logical interface. It could be a VLAN ID, MPLS Tag or Segment ID. This is assigned uniquely per slice.

From the Transport Network domain side, these parameters assist on the definition of the CE transport interface configuration and shall be taken as an input to the transport service model to create coherent Network Slice transport service. Fig. Z illustrates how the EP_Transport parameters can relate to the IETF ones for determining the endpoint connectivity.

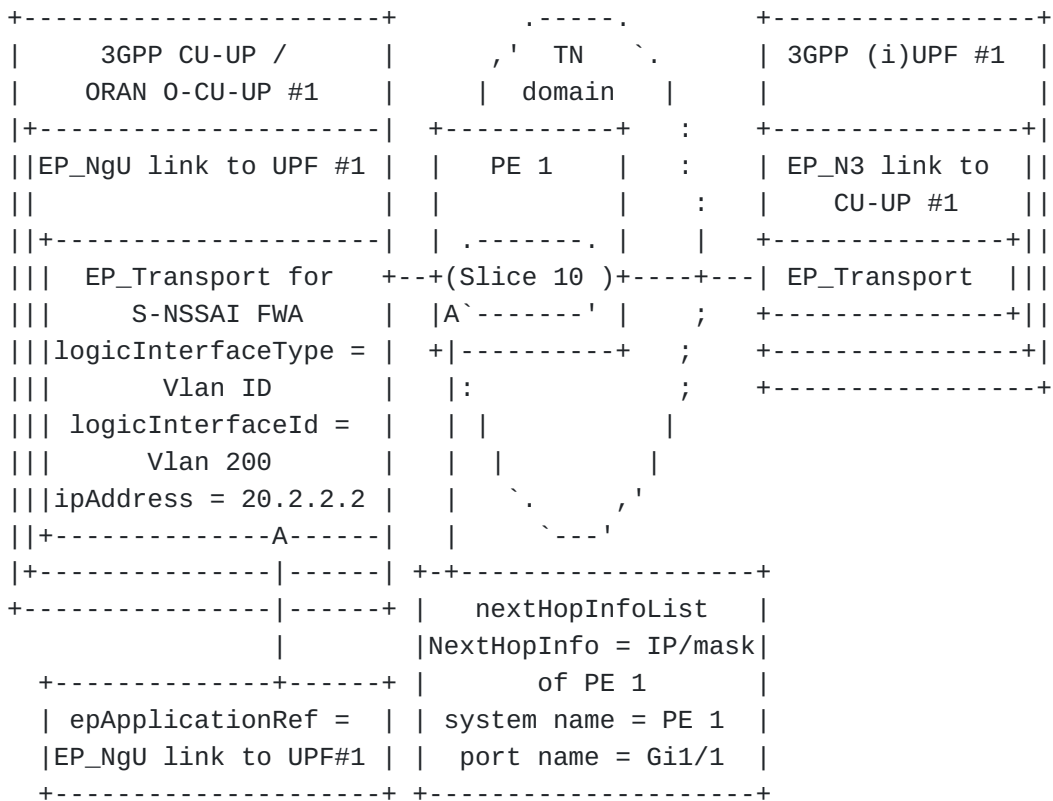

Figure 5-3 Example of 3GPP EP_Transport IOC TS28.541 parameters with correlation to IETF

Furthermore, that same parameters should be leveraged for constituting the connectivity construct allowing endpoint interconnection. That is, there is no additional information that could be leveraged at service level that the one provided by EP_Transport, which essentially reflects an endpoint view. Fig. W represents this relationship between 3GPP and IETF parameters.



Representation of connectivity:
 EP_NgU/N3, link between (0)-CU-UP and UPF
 F1-U, link between (0)-DU and (0)-CU-UP

Figure 5-4 Relationships of the 3GPP parameters with the IETF parameters

Leveraging on the EP_Transport information, the IETF NSC should be instructed through its NBI on performing the slice connection. Fig. Q graphically represents the slice connection (e.g., for Ng-U/N3) as expected by 3GPP by using connectivity constructs (of a IETF Network Slice service) to be configured by the IETF Network Slice Controller.

Slices in 3GPP domain
Model defined in IOC TS 28.541

Slices in 3GPP domain
Model defined in IOC TS 28.541

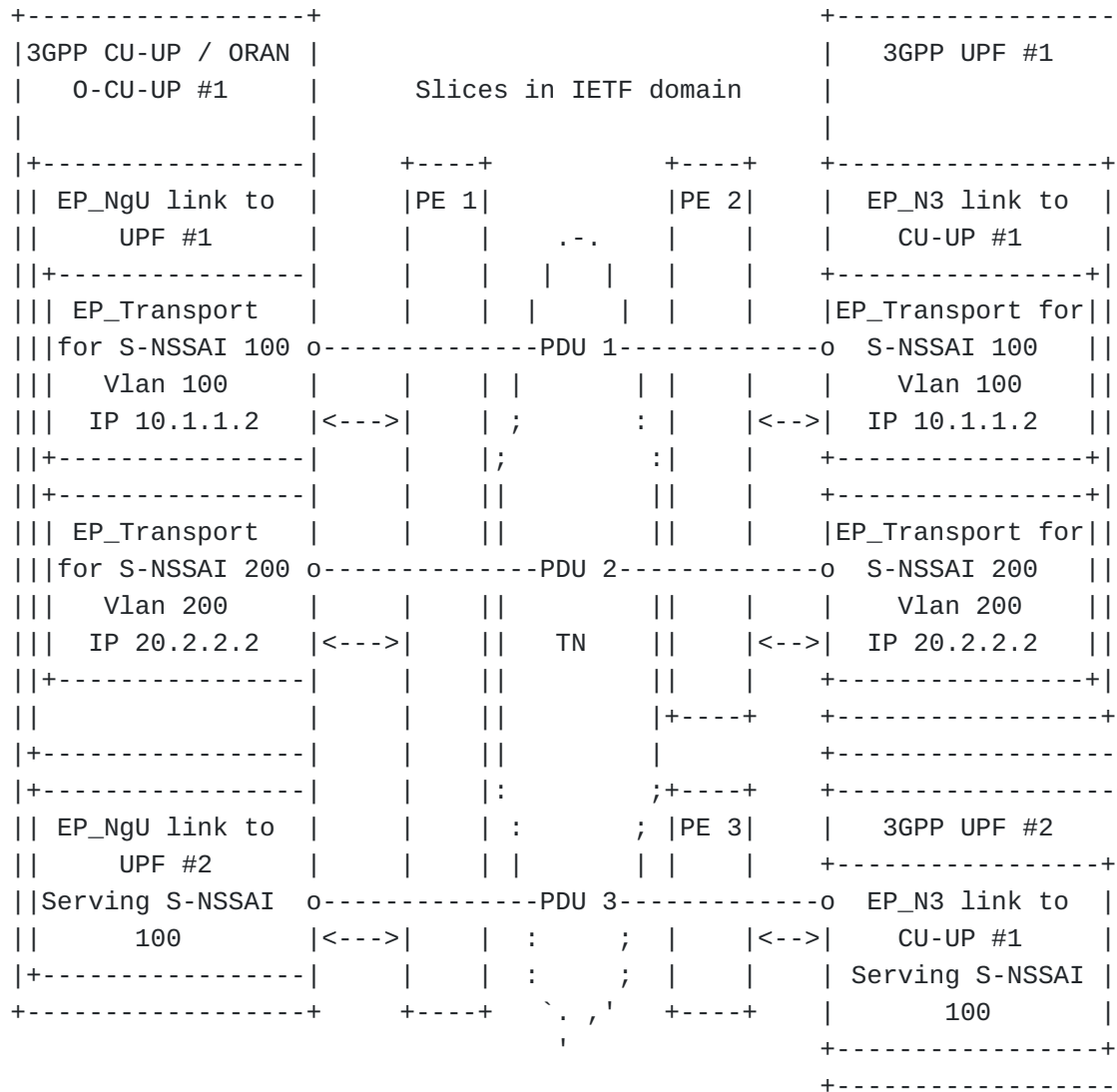

Figure 5-5 Example of CU-UP Slice in the 3GPP domain using an IETF Netwo

From the perspective of IETF Network Slice realization, some of these options could be realized in a straightforward manner while other could require of advanced features (e.g., PBR, SRv6, FlexE, etc). IETF Network Slice service may be a set of techniques and underlying technologies, so multiple models may be used to define slice.

According to the [TS28.541] attributes in the EP_Transport, the IETF Network Slice may be defined by the following combination of the parameters:

EP_Transport attribute name			
ipAddress	logicInterfaceId	nextHopInfo	qosProfile
	Different per slice		Same for all slices
Same for all slices		Different per slice	Same for all slices
Different per slice	Same for all slices	Different per slice	Same for all slices
	Same for all slices	Different per slice	Same for all slices
		Different per slice	
Same for all slices		Different per slice	

From the perspective of IETF Network Slice realization, some of these options could be realized in a straightforward manner while other could require of advanced features (e.g., PBR, SRv6, FlexE, etc).

IETF Network Slice service may be a set of techniques and underlying technologies, so multiple models may be used to define slice.

6. 5G E2E Network Slice Mapping Procedure

This section provides a general procedure of network slice mapping:

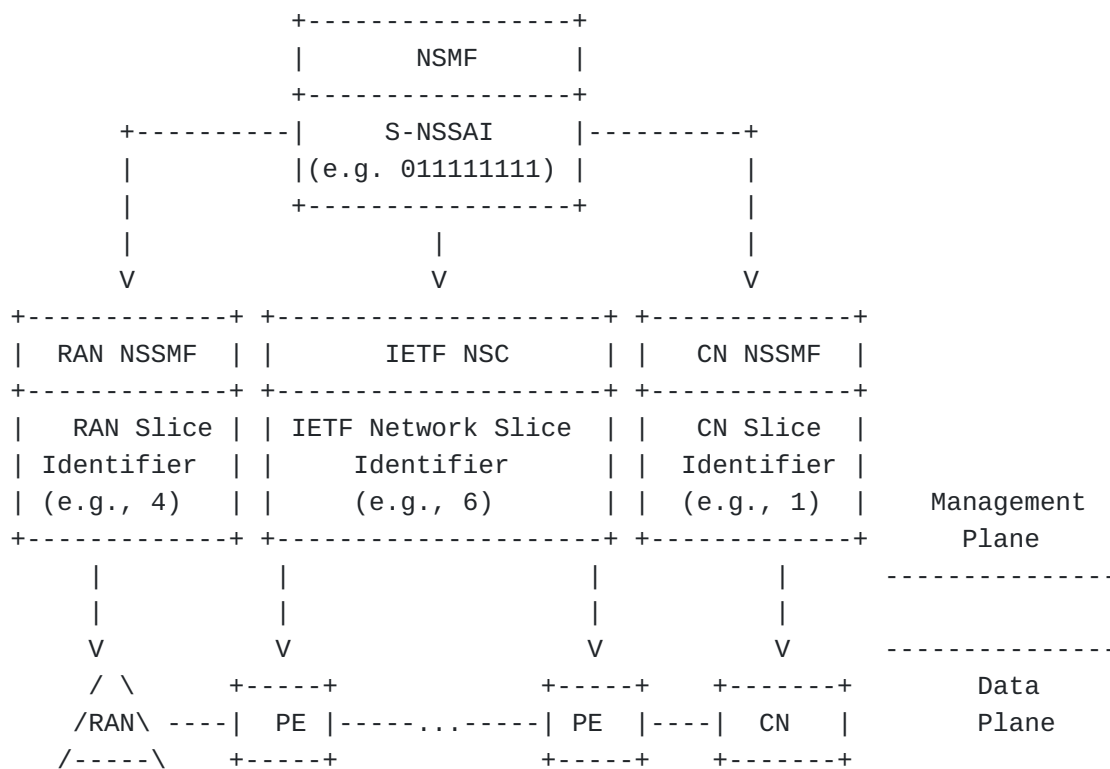

Figure-6 Relation between IETF and 3GPP Network Slice management

1. 3GPP NSMF receives the request from 3GPP CSMF for allocation of a network slice instance with certain characteristics.
2. Based on the service requirement, 3GPP NSMF acquires requirements for the end-to-end network slice instance, which is defined in Service Profile([TS28541] section 6.3.3).
3. Based on Service Profile, 3GPP NSMF identified the network function and the required resources in AN, CN and TN networks. It also assigns the unique ID S-NSSAI.
4. 3GPP NSMF sends a request to AN NSSMF for creation of AN Slice, out of the scope of this document.
5. 3GPP NSMF sends a request to CN NSSMF for creation of CN Slice, out of the scope of this document.
6. 3GPP NSMF sends a request to IETF Network Slice Controller (NSC) (acting as an NSSMF for transport connectivity, or TN NSSMF, from the perspective of the 3GPP Management System) for creation of IETF Network Slice. The request contains attributes such as endpoints (based on the information from EP_Transport IOC), required SLA/SLO along with other IETF network slice attributes. It also contains mapping information for IETF Network Slice Interworking Identifier.

Note: term "TN NSSMF" under discussion to ensure consistency with 3GPP specifications.

7. IETF NSC realizes the IETF network slice which satisfies the requirements of the IETF network slice service requested between the specified endpoints (RAN/ CN edge nodes). It may assign sliceID and send it to 3GPP NSMF.

Note: Consistency with the YANG NBI model should be ensured on parameters being passed between components

8. 3GPP NSMF maintains the mapping relationship between S-NSSAI and IETF Network Slice Service ID;

9. When the User Equipment (UE) appears, and during the 5G signaling, it requests to be connected to specific e2e network slice identified by S-NASSI. Then a GTP tunnel (which is UDP/IP-based) will be created.

10. UE starts sending traffic in context of e2e network slice for specific S-NASSI.

11. The endpoints of the 5G network slice in AN encapsulates the packet into a GTP tunnel, adds a Slice Interworking Identifier according to the selected S-NSSAI and send it to the transport network.

12. The transport network edge nodes parse the Slice Interworking identifier in the received packet and maps the packet to the corresponding IETF network slice. It may encapsulate the packet with slice specific identifiers for enforcing the SLA of IETF Network Slice service in the in transport network.

Note: steps 11 and 12 under discussion since they could depend on specific realization mechanisms.

6.1. 5G E2E Network Slice Mapping in Management Plane

The transport network management Plane maintains the interface between 3GPP NSMF and TN NSSMF, which 1) guarantees that IETF network slice could connect the AN and CN with specified characteristics that satisfy the requirements of communication; 2) builds up the mapping relationship between NSI identifier and any other identifier potentially used by the IETF NSC; 3) maintains the end-to-end slice relevant functions.

Service Profile defined in [\[TS28541\]](#) represents the requirement of end-to-end network slice instance in 5G network. Parameters defined in Service Profile include Latency, resource sharing level, availability and so on. How to decompose the end-to-end requirement

to the transport network requirement is one of the key issues in Network slice requirement mapping. GSMA (Global System for Mobile Communications Association) defines the [GST] to indicate the network slice requirement from the view of service provider. [I-D.ietf-teas-ietf-network-slice-use-cases] analyzes the parameters of GST and categorize the parameters into three classes, including the attributes with direct impact on the IETF network slice definition. It is a good start for selecting the transport network relevant parameters in order to define Network Slice Profile for Transport Network. Network slice requirement parameters are also necessary for the definition of transport network northbound interface.

Inside the IETF NSC (playing the role of TN NSSMF in 3GPP scope), it is supposed to be responsible of maintaining the attributes of the IETF network slice. If the attributes of an existing IETF Network Slice service could satisfy the requirement from the 3GPP Network Slice Profile, an existing IETF network slice could be selected and the mapping is then finished. In case there is no existing IETF Network Slice which could satisfy the requirement, a new IETF Network Slice is supposed to be created by the IETF NSC with the requested attributes.

IETF Network Slice resource reservation should be considered to avoid over allocation from multiple requests from 3GPP NSMF (but the detailed mechanism is out of scope of this draft)

3GPP TN NSSMF will request the IETF Network Slice service adding in the IETF Network Slice service request some slice identifier to the IETF NSC. The mapping relationship between NSI identifier and IETF Network Slice service identifier could be maintained in both 3GPP NSMF and IETF NSC.

Then, at the time of provisioning a 3GPP slice, it is required to provide slice connectivity constructs by means of IETF network slices. Then it is necessary to bind two different endpoints, as depicted in Figure 2:

*Mapping of EP_Transport (as defined by [TS28.541]) to the endpoint at the CE side of the IETF network slice. This is necessary because the IETF Network Slice Controller (NSC) will receive as input for the IETF network slice service the set of endpoints at CE side to be interconnected

*Mapping of the endpoints at both CE and PE side. The endpoint at PE side should be elicited by some means by the IETF NSC, in order to establish and set up the connectivity construct intended for the customer slice request, according to the SLOs and SLEs received from the higher level system.

3GPP concern

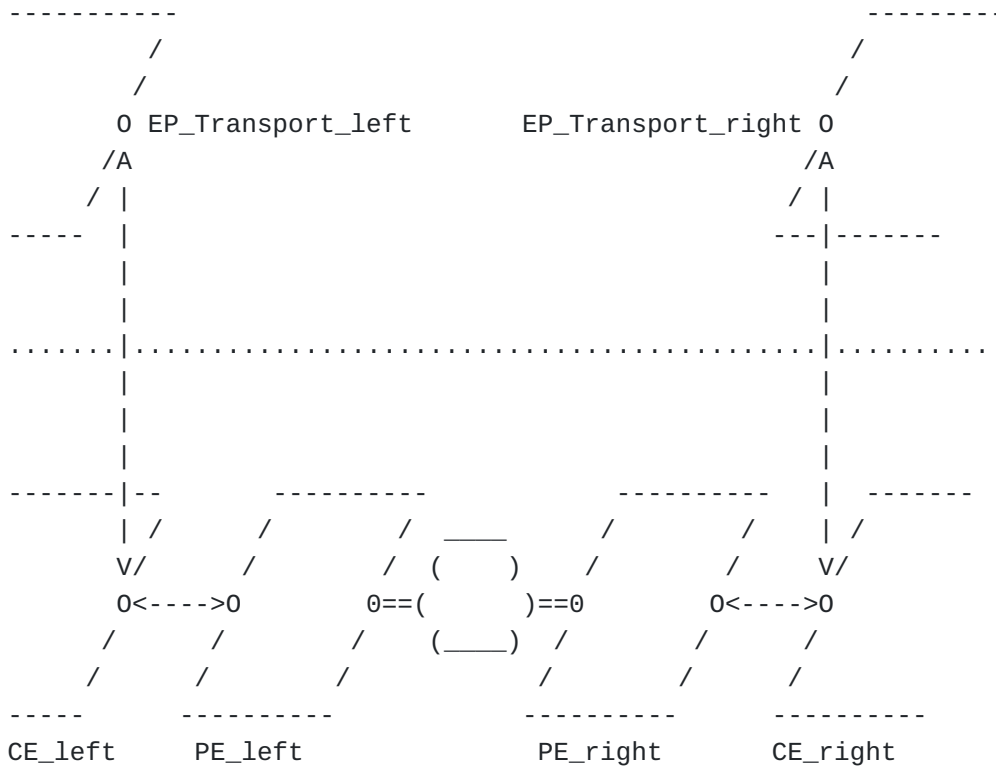

IETF concern

6.1.1. Mapping EP_transport to IETF NS CE endpoints

The 3GPP Management system provides the EP_Transport IOC to extend the slice awareness to the transport network. The EP_Transport IOC contains parameters as IP address, additional identifiers (i.e., vlan tag, MPLS label, etc), and associated QoS profile. This IOC is related to the endpoints of the 3GPP managed functions (detailed in the EP_Application IOC).

The information captured in the EP_Transport IOC (as part of the 3GPP concern) should be translated into the CE related parameters (as part of the IETF concern). There will be cases where such translation is straightforward, as for instance, when the 3GPP managed functions run on monolithic, purpose-specific network elements, in the way that the IP address attribute from the EP_Transport IOC directly corresponds to the IP address of an interface of such network element. In this case, the information on EP_Transport IOC can be directly passed to the IETF NSC through the NBI, even though some additional information could be yet required, not being defined yet on 3GPP specifications (e.g., the mask applicable to the IP address field on EP_Transport). Note that information gaps are further detailed in a summary section at the end of this document.

However, there could be other cases where such a relationship is not straightforward. This could be the case of virtualized 3GPP managed functions that could be instantiated on a general-purpose bare-metal server or in a data center. In these other cases it is necessary to define additional means for eliciting the endpoint at the CE side corresponding to the endpoint of the 3GPP-related function.

With solely EP_Transport characterization in 3GPP as today (i.e., according to 3GPP Release 16 specifications), we could expect the NS CE endpoint being identified by a combination of IP address and some additional information such as vlan tag, MPLS label or SR SID that could discriminate against a certain logical interface. The next hop router information is related to the next hop view from the perspective of the 3GPP entity part of the slice, then providing hints for determining the slice endpoint at the other side of the slice boundary. Finally, the QoS profile, if present, helps to determine configurations needed at the PE side to respect the SLOs in the connection between CEs slice endpoints.

6.1.2. Mapping IETF NS CE to PE endpoints

As described in [I-D.ietf-teas-ietf-network-slices], there are different potential endpoint positions for an IETF NS.

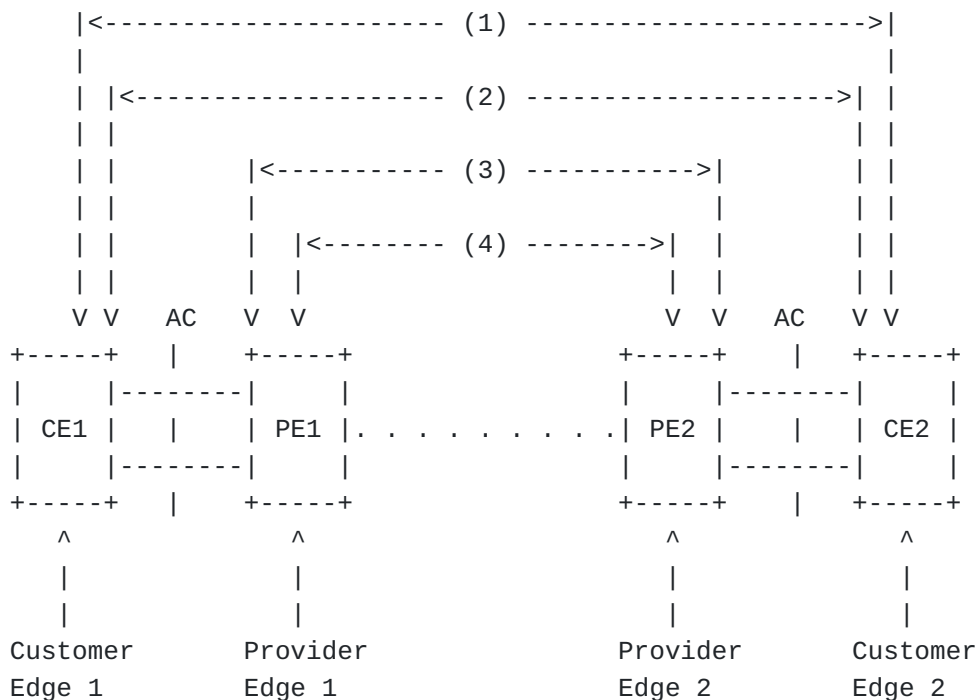

Figure 7: IETF Network Slice endpoints

The information that is passed to the IETF NSC in terms of endpoints is the information relative to the CE side, which is the one known

by the slice customer (i.e., the 3GPP Management system, that corresponds to the 3GPP managed functions). From that information, the IETF NSC needs to infer the corresponding endpoint at the PE side, in order to setup the desired connectivity constructs with the SLOs indicated in the request.

Being the IETF slice request a technology-agnostic procedure, the identification of the slice endpoints at the PE side should leverage on generic information passed through the NBI to the IETF NSC.

6.2. 5G E2E Network Slice Mapping in Control Plane

There is no explicit interaction between transport network and AN/CN in the control plane, but the S-NSSAI defined in [\[TS23501\]](#) is treated as the end-to-end network slice identifier in the control plane of AN and CN, which is used in UE registration and PDU session setup. In this draft, it is assumed that there is a correspondence between S-NSSAI and the IETF Network Slice service identifier in the management plane.

Note: to ensure consistency with NBI YANG model (i.e., service tag)

6.3. 5G E2E Network Slice Mapping in Data Plane

If multiple network slices are carried through one physical interface between AN/CN and TN, IETF Network Slice Interworking ID in the data plane needs to be defined. If different network slices are transported through different physical interfaces, Network Slices could be distinguished by the interface directly. Thus IETF Network Slice Interworking ID is not the only option for network slice mapping, while it may help in introducing new network slices.

6.3.1. Data Plane Mapping Considerations

The mapping relationship between AN or CN network slice and an IETF Network Slice will be based on a IETF Network Slice Interworking identifier based on the information provided by the EP_Transport IOC. When the packet of an uplink flow goes from AN to TN, the packet is delivered according to the information provided by the EP_Transport IOC (e.g., the information provided in the logicalInterface field); then the encapsulation is read by the edge node of transport network, which maps the packet to the corresponding IETF network slice.

6.3.2. Data Plane Mapping Options

The following picture shows the end-to-end network slice in data plane:

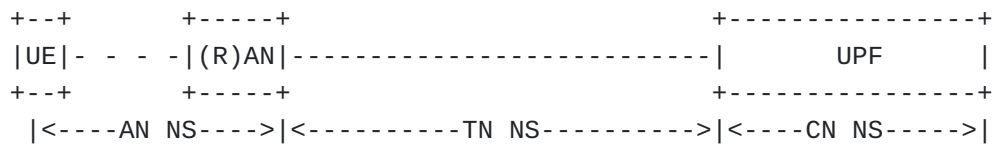

The mapping between 3GPP slice and transport slice in user plane could happens in:

(R)AN: User data goes from (radio) access network to transport network

UPF: User data goes from core network functions to transport network

Editor's Note: As figure 4.7.1. in [TS28530] describes, TN NS will not only exist between AN and CN but may also within AN NS and CN NS. However, here we just show the TN between AN and CN as an example to avoid unnecessary complexity.

The following picture shows the user plane protocol stack in end-to-end 5G system.

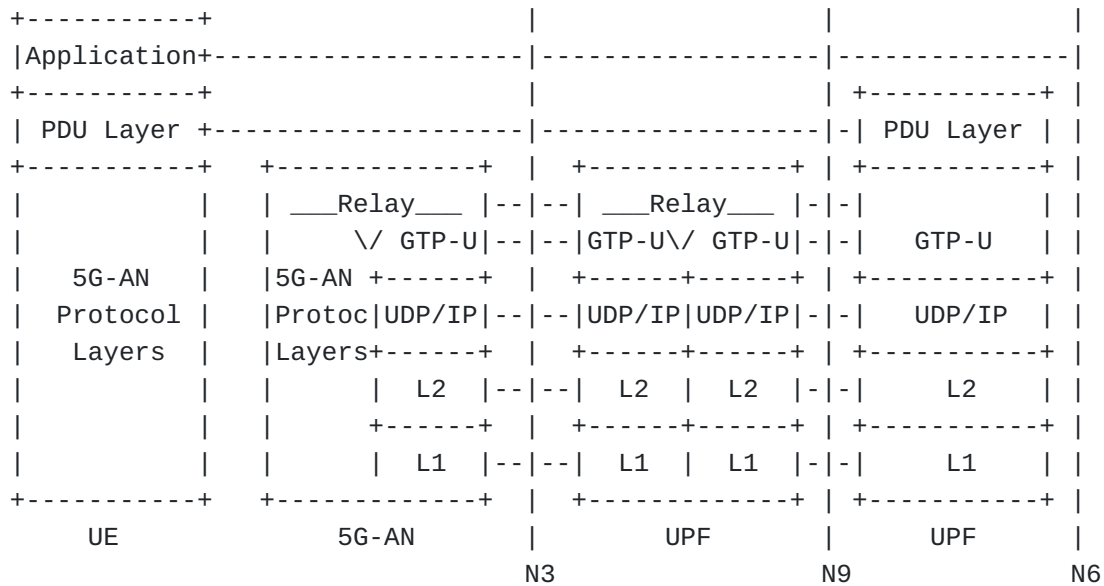

The following figure shows the typical encapsulation in N3 interface.

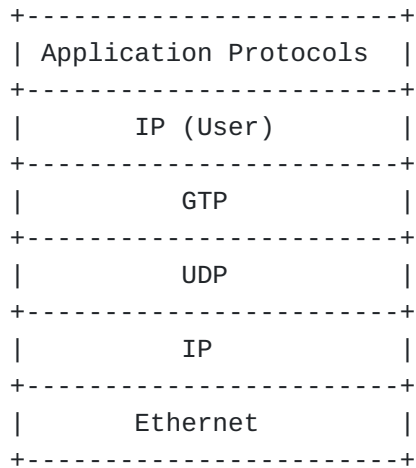

6.3.2.1. Layer 3 and Layer 2 Encapsulations

If the encapsulation above IP layer is not visible to Transport Network, it is not able to be used for network slice interworking with transport network. In this case, IP header and Ethernet header could be considered to provide information of network slice interworking from AN or CN to TN.

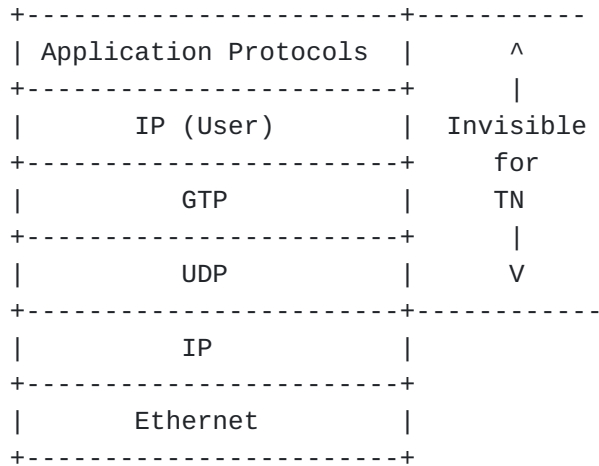

The following field in IP header and Ethernet header could be considered :

IP Header:

*DSCP: It is traditionally used for the mapping of QoS identifier between AN/CN and TN network. Although some values (e.g. The unassigned code points) may be borrowed for the network slice interworking, it may cause confusion between QoS mapping and network slicing mapping.;

*Destination Address: It is possible to allocate different IP addresses for entities in different network slice, then the

destination IP address could be used as the network slice interworking identifier. However, it brings additional requirement to IP address planning. In addition, in some cases some AN or CN network slices may use duplicated IP addresses.

*Option fields/headers: It requires that both AN and CN nodes can support the encapsulation and decapsulation of the options.

Ethernet header

*VLAN ID: It is widely used for the interconnection between AN/CN nodes and the edge nodes of transport network for the access to different VPNs. One possible problem is that the number of VLAN ID can be supported by AN nodes is typically limited, which effects the number of IETF network slices a AN node can attach to. Another problem is the total amount of VLAN ID (4K) may not provide a comparable space as the network slice identifiers of mobile networks.

Two or more options described above may also be used together as the IETF Network Slice Interworking ID, while it would make the mapping relationship more complex to maintain.

In some other case, when AN or CN could support more layer 3 encapsulations, more options are available as follows:

If the AN or CN could support MPLS, the protocol stack could be as follows:

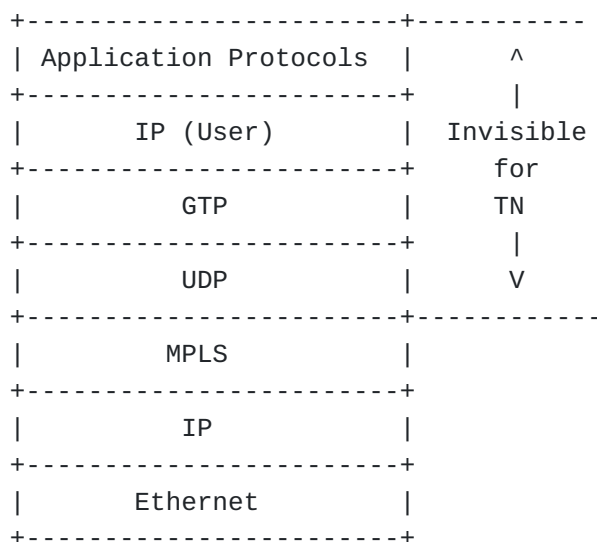

A specified MPLS label could be used to as a IETF Network Slice Interworking ID.

If the AN or CN could support SRv6, the protocol stack is as follows:

Application Protocols	^
IP (User)	Invisible
GTP	for
UDP	TN
SRH	
IPv6	
Ethernet	V

The following field could be considered to identify a network slice:

SRH:

*SRv6 functions: AN/CN is supposed to support the new function extension of SRv6.

*Optional TLV: AN/CN is supposed to support the extension of optional TLV of SRH.

6.3.2.2. Above Layer 3 Encapsulations

If the encapsulation above IP layer is visible to Transport Network, it is able to be used to identify a network slice. In this case, UDP and GTP-U could be considered to provide information of network slice interworking between AN or CN and TN.

Application Protocols	
IP (User)	Invisible
GTP	for
UDP	TN
IP	
Ethernet	

The following field in UDP header could be considered:

UDP Header:

*UDP Source port: The UDP source port is sometimes used for load balancing. Using it for network slice mapping would require to disable the load-balancing behavior.

A similar approach to this is followed in [\[I-D.ietf-dmm-tn-aware-mobility\]](#)

6.3.2.3. Summary

From all the options overviewed, it should be noted that current 3GPP Release 16 only supports through EP_Transport IOC the following slice handoff identifier: vlan tag. MPLS or SID labels. Thus, the consideration of more options as the ones here reported is a gap on 3GPP specifications.

7. Example of IETF Network Slice request through IETF Network Slice NBI

As discussed in [\[I-D.ietf-teas-ietf-network-slices\]](#), to fulfill IETF network slices and to perform monitoring on them, an entity called IETF Network Slice Controller (NSC) is required to take abstract requests for IETF network slices and realize them using suitable underlying technologies. An IETF Network Slice Controller is the key building block for control and management of the IETF network slice. It provides the creation/modification/deletion, monitoring and optimization of transport Slices in a multi-domain, a multi-technology and multi-vendor environment.

Figure 8 shows the NSC and its NBI interface for 5G. Draft [\[I-D.ietf-teas-ietf-network-slice-nbi-yang\]](#) addresses the service yang model of the NSC NBI interface for all network slicing use-cases.

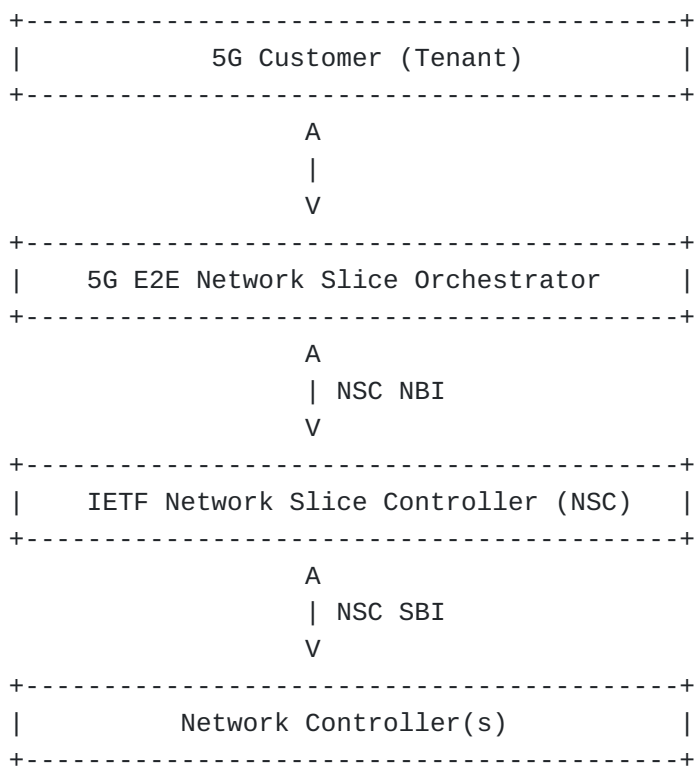

Figure 8: IETF Network Slice Controller NBI for 5G

As discussed in [[I-D.ietf-teas-ietf-network-slices](#)], the main task of the IETF Network Slice Controller is to map abstract IETF network slice requirements from NBI to concrete technologies on SBI and establish the required connectivity, and ensure that required resources are allocated to IETF network slice. There are a number of different technologies that can be used on SBI including physical connections, MPLS, TSN, Flex-E, PON etc. If the undelay technology is IP/MPLS/Optics, any IETF models can be used during the realization of IETF network slice.

There are no specific mapping requirements for 5G. The only difference is that in case of 5G, the NBI interface contains additional 5G specific attributes such as customer name, mobile service type, 5G E2E network slice ID (i.e. S-NSSAI) and so on (See Section 6). These 5G specific attributes can be employed by IETF Network Slice Controller during the realization of 5G IETF network slices on how to map NBI to SBI. They can also be used for assurance of 5G IETF network slices. Figure 9 shows the mapping between NBI to SBI for 5G IETF network slices.

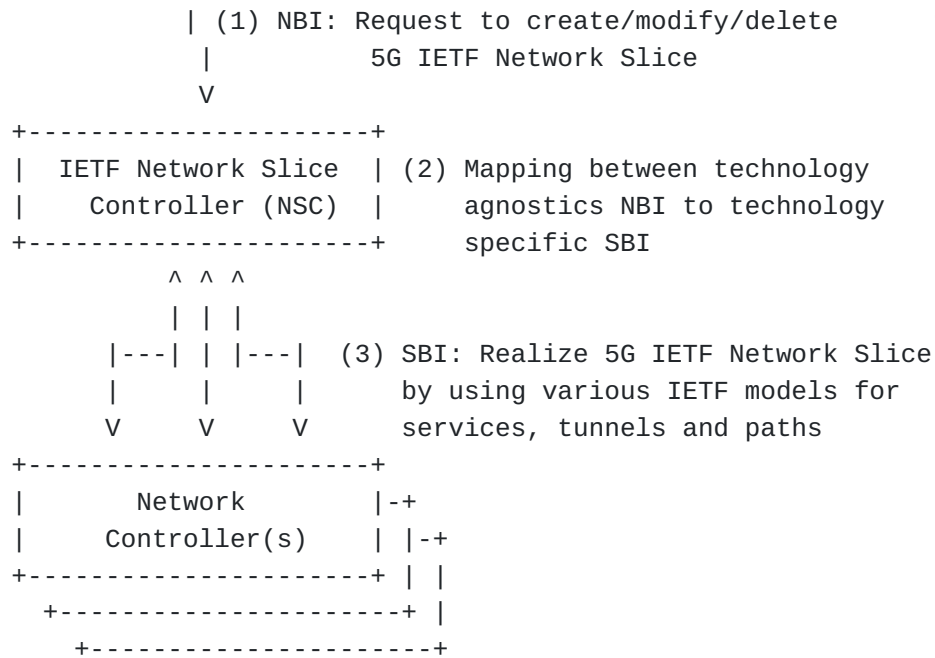

Figure 9: Relationship between transport slice interface and IETF Service/Tunnels/Path data models

8. Gap Analysis

The way in which 3GPP is characterizing the slice endpoint (i.e., EP_Transport) is based on Layer 3 information (e.g., the IP Address). However the information provided seems not to be sufficient for instructing the IETF Network Slice Controller for the realization of the IETF Network Slice. For instance, some basic information such as the mask associated to the IP address of the EP_Transport is not specified, as well as other kind of parameters like the connection MTU or the connectivity type (unicast, multicast, etc). More sophisticated information could be required as well, like the level of isolation or protection necessary for the intended slice.

In the case in which the 3GPP managed function runs on a purpose-specific network element, the IP address specified in the EP_Transport IOC serves as reference to identify the CE endpoint, assuming the endpoint of the CE has been configured with that IP address. With that information (together with the logical interface ID) should be sufficient for the IETF NSC to identify the counterpart endpoint at the PE side, and configuring it accordingly (e.g., with a compatible IP address) for setting up the slice end-to-end. Similarly, the next hop information in EP_Transport can help validate the end-to-end slice between PE endpoints.

In the case in which the 3GPP managed function is instantiated as a virtualized network function, the direct association between the IP address of EP_Transport and the actual endpoint mapped at the CE is not so clear. It could be the case, for instance when the virtualized network function is instantiated at the internal of a data center, that the CE facing the PE is far from the point where the function is deployed, being that connectivity extended through the internals of the data center (or by some internal configuration of a virtual switch in a server). In these situations additional information is needed for accomplishing the end-to-end connection.

At the same time, [TS28.541] IOC contains useful parameters to be used in IETF Network Slice creation mechanism and enreaching IETF Network Slice model. The following parameters may be suggested as a candidates to the correlation of the IETF Network Slice parameters and IETF Network Slice model enreachments:

*For the latency, dLThptPerSliceSubnet, uLThptPerSliceSubnet, reliability and delayTolerance attributes, the following NRM apply (with reference to the section in that specification):

- * -CNSliceSubnetProfile (section 6.3.22 in [TS28.541])
- RANSliceSubnetProfile (section 6.3.23 in [TS28.541])
- TopSliceSubnetProfile (section 6.3.24 in [TS28.541])

*For the qosProfile attribute, the NRM which applies is EP_Transport (detailed in section 6.3.17 in [TS28.541])

9. IANA Considerations

This document makes no request of IANA.

Note to RFC Editor: this section may be removed on publication as an RFC.

10. Security Considerations

11. Acknowledgements

The work of Luis M. Contreras has been partially funded by the European Commission under Horizon 2020 project Int5Gent (grant agreement 957403).

Thanks to Philip Eardley (philip.eardley@bt.com) for his contribution to this document.

12. Contributors

Jose Ordonez-Lucena

Telefonica

Ronda de la Comunicacion,

s/n Sur-3 building,

3rd floor Madrid 28050 Spain

Email: joseantonio.ordonezlucena@telefonica.com

Ran Pang

China Unicom

Email: pangran@chinaunicom.cn

Liuyan Han

China Mobile

Email: hanliuyan@chinamobile.com

Jaehwan Jin

LG U+

Email: daenam1@lguplus.co.kr

Jeff Tantsura

Microsoft

Email: jefftant.ietf@gmail.com

Shunsuke Homma

NTT 3-9-11,

Midori-cho Musashino-shi,

Tokyo 180-8585 Japan

Email: shunsuke.homma.ietf@gmail.com

Xavier de Foy

InterDigital Inc.

Canada

Email: Xavier.Defoy@InterDigital.com

Kiran Makhijani

Futurewei Networks

US

Email: kiranm@futurewei.com

Hannu Flinck

Nokia

Finland

Email: hannu.flinck@nokia-bell-labs.com

Rainer Schatzmayr

Deutsche Telekom

Germany

Email: rainer.schatzmayr@telekom.de

Ali Tizghadam

TELUS Communications Inc

Canada

Email: ali.tizghadam@telus.com

Christopher Janz

Huawei Canada

Canada

Email: christopher.janz@huawei.com

Henry Yu

Huawei Canada

Canada

Email: henry.yu1@huawei.com

13. References

13.1. Normative References

[GST] "Generic Network Slice Template", <<https://www.gsma.com/newsroom/all-documents/generic-network-slice-template-v2-0/>>.

[I-D.ietf-dmm-tn-aware-mobility]

Chunduri, U., Kaippallimalil, J., Bhaskaran, S., Tantsura, J., and P. Muley, "Mobility aware Transport Network Slicing for 5G", Work in Progress, Internet-Draft, draft-ietf-dmm-tn-aware-mobility-05, 19 October 2022, <<https://datatracker.ietf.org/doc/html/draft-ietf-dmm-tn-aware-mobility-05>>.

[I-D.ietf-teas-ietf-network-slice-definition]

Rokui, R., Homma, S., Makhijani, K., Contreras, L. M., and J. Tantsura, "Definition of IETF Network Slices", Work in Progress, Internet-Draft, draft-ietf-teas-ietf-network-slice-definition-01, 22 February 2021, <<https://datatracker.ietf.org/doc/html/draft-ietf-teas-ietf-network-slice-definition-01>>.

[I-D.ietf-teas-ietf-network-slice-nbi-yang]

Wu, B., Dhody, D., Rokui, R., Saad, T., Han, L., and J. Mollooly, "IETF Network Slice Service YANG Model", Work in Progress, Internet-Draft, draft-ietf-teas-ietf-network-slice-nbi-yang-03, 24 October 2022, <<https://datatracker.ietf.org/doc/html/draft-ietf-teas-ietf-network-slice-nbi-yang-03>>.

[I-D.ietf-teas-ietf-network-slice-use-cases]

Contreras, L. M., Homma, S., Ordonez-Lucena, J. A., Tantsura, J., and H. Nishihara, "IETF Network Slice Use Cases and Attributes for the Slice Service Interface of IETF Network Slice Controllers", Work in Progress, Internet-Draft, draft-ietf-teas-ietf-network-slice-use-cases-01, 24 October 2022, <<https://datatracker.ietf.org/doc/html/draft-ietf-teas-ietf-network-slice-use-cases-01>>.

[I-D.ietf-teas-ietf-network-slices]

Farrel, A., Drake, J., Rokui, R., Homma, S., Makhijani, K., Contreras, L. M., and J. Tantsura, "A Framework for IETF Network Slices", Work in Progress, Internet-Draft, draft-ietf-teas-ietf-network-slices-19, 21 January 2023, <<https://datatracker.ietf.org/doc/html/draft-ietf-teas-ietf-network-slices-19>>.

[I-D.srld-teas-5g-slicing]

Szarkowicz, K. G., Roberts, R., Lucek, J., Drake, J., Boucadair, M., Contreras, L. M., Bykov, I., Rokui, R., Jalil, L., Setyawan, B. D., Dhamija, A., and M. Amani, "A Realization of IETF Network Slices for 5G Networks Using Current IP/ MPLS Technologies", Work in Progress, Internet-Draft, draft-srld-teas-5g-slicing-05, 13 January 2023, <<https://datatracker.ietf.org/doc/html/draft-srld-teas-5g-slicing-05>>.

[RFC2119] Bradner, S., "Key words for use in RFCs to Indicate Requirement Levels", BCP 14, RFC 2119, DOI 10.17487/RFC2119, March 1997, <<https://www.rfc-editor.org/info/rfc2119>>.

[TS23501] "3GPP TS23.501", <<https://portal.3gpp.org/desktopmodules/Specifications/SpecificationDetails.aspx?specificationId=3144>>.

[TS28530] "3GPP TS28.530", <<https://portal.3gpp.org/desktopmodules/Specifications/SpecificationDetails.aspx?specificationId=3273>>.

[TS28531] "3GPP TS28.531", <<https://portal.3gpp.org/desktopmodules/Specifications/SpecificationDetails.aspx?specificationId=3274>>.

[TS28541] "3GPP TS 28.541", <<https://portal.3gpp.org/desktopmodules/Specifications/SpecificationDetails.aspx?specificationId=3400>>.

[ZSM003] "ETSI ZSM003", <<https://portal.3gpp.org/desktopmodules/Specifications/SpecificationDetails.aspx?specificationId=3144>>.

13.2. Informative References

[InfRef] "", 2004.

Appendix A. An Appendix

Authors' Addresses

Xuesong Geng
Huawei Technologies

Email: gengxuesong@huawei.com

Luis M. Contreras
Telefonica

Email: luismiguel.contrerasmurillo@telefonica.com

Reza Rokui
Ciena

Email: rrokui@ciena.com

Jie Dong
Huawei Technologies

Email: jie.dong@huawei.com

Ivan Bykov
Ribbon Communications

Email: Ivan.Bykov@rbbn.com