

61o  
Internet-Draft  
Updates: [6775](#), [8505](#) (if approved)  
Intended status: Standards Track  
Expires: August 8, 2019

P. Thubert, Ed.  
Cisco Systems  
C. Perkins  
Futurewei  
E. Levy-Abegnoli  
Cisco Systems  
February 4, 2019

**IPv6 Backbone Router**  
**draft-ietf-61o-backbone-router-11**

Abstract

This document updates [RFC 4861](#) and [RFC 8505](#) in order to enable proxy services for IPv6 Neighbor Discovery by Routing Registrars called Backbone Routers. Backbone Routers are placed along the wireless edge of a Backbone, and federate multiple wireless links to form a single MultiLink Subnet.

Status of This Memo

This Internet-Draft is submitted in full conformance with the provisions of [BCP 78](#) and [BCP 79](#).

Internet-Drafts are working documents of the Internet Engineering Task Force (IETF). Note that other groups may also distribute working documents as Internet-Drafts. The list of current Internet-Drafts is at <https://datatracker.ietf.org/drafts/current/>.

Internet-Drafts are draft documents valid for a maximum of six months and may be updated, replaced, or obsoleted by other documents at any time. It is inappropriate to use Internet-Drafts as reference material or to cite them other than as "work in progress."

This Internet-Draft will expire on August 8, 2019.

Copyright Notice

Copyright (c) 2019 IETF Trust and the persons identified as the document authors. All rights reserved.

This document is subject to [BCP 78](#) and the IETF Trust's Legal Provisions Relating to IETF Documents (<https://trustee.ietf.org/license-info>) in effect on the date of publication of this document. Please review these documents carefully, as they describe your rights and restrictions with respect to this document. Code Components extracted from this document must

include Simplified BSD License text as described in Section 4.e of the Trust Legal Provisions and are provided without warranty as described in the Simplified BSD License.

Table of Contents

- [1. Introduction](#) . . . . . [2](#)
- [2. Terminology](#) . . . . . [4](#)
  - [2.1. BCP 14](#) . . . . . [4](#)
  - [2.2. New Terms](#) . . . . . [5](#)
  - [2.3. Acronym Definitions](#) . . . . . [6](#)
  - [2.4. References](#) . . . . . [7](#)
- [3. Overview](#) . . . . . [7](#)
  - [3.1. Updating RFC 6775 and RFC 8505](#) . . . . . [9](#)
  - [3.2. Access Link](#) . . . . . [10](#)
  - [3.3. Route-Over Mesh](#) . . . . . [11](#)
  - [3.4. The Binding Table](#) . . . . . [12](#)
  - [3.5. Primary and Secondary 6BBRs](#) . . . . . [13](#)
  - [3.6. Using Optimistic DAD](#) . . . . . [14](#)
- [4. MultiLink Subnet Considerations](#) . . . . . [14](#)
- [5. Optional 6LBR serving the MultiLink Subnet](#) . . . . . [15](#)
- [6. Using IPv6 ND Over the Backbone Link](#) . . . . . [15](#)
- [7. Routing Proxy Operations](#) . . . . . [16](#)
- [8. Bridging Proxy Operations](#) . . . . . [17](#)
- [9. Creating and Maintaining a Binding](#) . . . . . [18](#)
  - [9.1. Operation on a Binding in Tentative State](#) . . . . . [19](#)
  - [9.2. Operation on a Binding in Reachable State](#) . . . . . [20](#)
  - [9.3. Operation on a Binding in Stale State](#) . . . . . [21](#)
- [10. Registering Node Considerations](#) . . . . . [22](#)
- [11. Security Considerations](#) . . . . . [23](#)
- [12. Protocol Constants](#) . . . . . [23](#)
- [13. IANA Considerations](#) . . . . . [23](#)
- [14. Acknowledgments](#) . . . . . [23](#)
- [15. References](#) . . . . . [24](#)
  - [15.1. Normative References](#) . . . . . [24](#)
  - [15.2. Informative References](#) . . . . . [25](#)
- [Appendix A. Possible Future Extensions](#) . . . . . [28](#)
- [Appendix B. Applicability and Requirements Served](#) . . . . . [28](#)
- [Authors' Addresses](#) . . . . . [30](#)

**1. Introduction**

IEEE STD. 802.1 [[IEEEstd8021](#)] Ethernet Bridging provides an efficient and reliable broadcast service for wired networks; applications and protocols have been built that heavily depend on that feature for their core operation. Unfortunately, Low-Power Lossy Networks (LLNs) and local wireless networks generally do not provide the broadcast capabilities of Ethernet Bridging in an economical fashion.



As a result, protocols designed for bridged networks that rely on multicast and broadcast often exhibit disappointing behaviours when employed unmodified on a local wireless medium (see [\[I-D.ietf-mboned-ieee802-mcast-problems\]](#)).

Wi-Fi [\[IEEEstd80211\]](#) Access Points (APs) deployed in an Extended Service Set (ESS) act as Ethernet Bridges [\[IEEEstd8021\]](#), with the property that the bridging state is established at the time of association. This ensures connectivity to the node (STA) and protects the wireless medium against broadcast-intensive Transparent Bridging reactive Lookups. In other words, the association process is used to register the MAC Address of the STA to the AP. The AP subsequently proxies the bridging operation and does not need to forward the broadcast Lookups over the radio.

Like Transparent Bridging, IPv6 [\[RFC8200\]](#) Neighbor Discovery [\[RFC4861\]](#) [\[RFC4862\]](#) Protocol (IPv6 ND) is a reactive protocol, based on multicast transmissions to locate an on-link correspondent and ensure the uniqueness of an IPv6 address. The mechanism for Duplicate Address Detection (DAD) [\[RFC4862\]](#) was designed for the efficient broadcast operation of Ethernet Bridging. Since broadcast can be unreliable over wireless media, DAD often fails to discover duplications [\[I-D.yourtchenko-6man-dad-issues\]](#). In practice, IPv6 addresses very rarely conflict because of the entropy of the 64-bit Interface IDs, not because address duplications are detected and resolved.

The IPv6 ND Neighbor Solicitation (NS) [\[RFC4861\]](#) message is used for DAD and address Lookup when a node moves, or wakes up and reconnects to the wireless network. The NS message is targeted to a Solicited-Node Multicast Address (SNMA) [\[RFC4291\]](#) and should in theory only reach a very small group of nodes. But in reality, IPv6 multicast messages are typically broadcast on the wireless medium, and so they are processed by most of the wireless nodes over the subnet (e.g., the ESS fabric) regardless of how few of the nodes are subscribed to the SNMA. As a result, IPv6 ND address Lookups and DADs over a large wireless and/or a LowPower Lossy Network (LLN) can consume enough bandwidth to cause a substantial degradation to the unicast traffic service.

Because IPv6 ND messages sent to the SNMA group are broadcasted at the radio MAC Layer, wireless nodes that do not belong to the SNMA group still have to keep their radio turned on to listen to multicast NS messages, which is a total waste of energy for them. In order to reduce their power consumption, certain battery-operated devices such as IoT sensors and smartphones ignore some of the broadcasts, making IPv6 ND operations even less reliable.



These problems can be alleviated by reducing the IPv6 ND broadcasts over wireless access links. This has been done by splitting the broadcast domains and routes between subnets, or even by assigning a /64 prefix to each wireless node (see [[RFC8273](#)]).

Another way is to proxy at the boundary of the wired and wireless domains the Layer-3 protocols that rely on MAC Layer broadcast operations. For instance, IEEE 802.11 [[IEEEstd80211](#)] situates proxy-ARP (IPv4) and proxy-ND (IPv6) functions at the Access Points (APs). The 6BBR provides a proxy-ND function and can be extended for proxy-ARP in a continuation specification.

IPv6 proxy-ND services can be obtained by snooping the IPv6 ND protocol (see [[I-D.bi-savi-wlan](#)]). Proprietary techniques for IPv6 ND and DHCP snooping have been used; although snooping does eliminate undesirable broadcast transmissions, it has been found to be unreliable. An IPv6 address may not be discovered immediately due to a packet loss, or if a "silent" node is not currently using one of its addresses. A change of state (e.g. due to movement) may be missed or misordered, leading to unreliable connectivity and incomplete knowledge of the state of the network.

This specification defines the 6BBR as a Routing Registrar [[RFC8505](#)] that provide proxy services for IPv6 Neighbor Discovery. Backbone Routers federate multiple LLNs over a Backbone Link to form a MultiLink Subnet (MLSN). Backbone Routers placed along the LLN edge of the Backbone handle IPv6 Neighbor Discovery, and forward packets on behalf of registered nodes.

An LLN node (6LN) registers all its IPv6 Addresses using an NS(EARO) as specified in [[RFC8505](#)] to the 6BBR. The 6BBR is also a Border Router that performs IPv6 Neighbor Discovery (IPv6 ND) operations on its Backbone interface on behalf of the 6LNs that have registered addresses on its LLN interfaces without the need of a broadcast over the wireless medium. Additional benefits are discussed in [Appendix B](#).

## **2. Terminology**

### **2.1. [BCP 14](#)**

The key words "MUST", "MUST NOT", "REQUIRED", "SHALL", "SHALL NOT", "SHOULD", "SHOULD NOT", "RECOMMENDED", "NOT RECOMMENDED", "MAY", and "OPTIONAL" in this document are to be interpreted as described in [BCP 14](#) [[RFC2119](#)] [[RFC8174](#)] when, and only when, they appear in all capitals, as shown here.



## [2.2.](#) New Terms

This document introduces the following terminology:

### Federated

A subnet that comprises a Backbone and one or more (wireless) access links, is said to be federated into one MultiLink Subnet. The proxy-ND operation of 6BBRs over the Backbone and the access links provides the appearance of a subnet for IPv6 ND.

### Sleeping Proxy

A 6BBR acts as a Sleeping Proxy if it answers ND Neighbor Solicitations over the Backbone on behalf of a Registered Node.

### Routing Proxy

A Routing Proxy provides IPv6 ND proxy functions and enables the MLSN operation over federated links that may not be compatible for bridging. The Routing Proxy advertises its own MAC Address as the TLLA in the proxied NAs over the Backbone, and routes at the Network Layer between the federated links.

### Bridging Proxy

A Bridging Proxy provides IPv6 ND proxy functions while preserving forwarding continuity at the MAC Layer. The Bridging Proxy advertises the MAC Address of the Registering Node as the TLLA in the proxied NAs over the Backbone. In that case, the MAC Address and the mobility of 6LN is still visible across the bridged Backbone, and the 6BR may be configured to proxy for Link Local Addresses.

### Binding Table

The Binding Table is an abstract database that is maintained by the 6BBR to store the state associated with its registrations.

### Binding

A Binding is an abstract state associated to one registration, in other words one entry in the Binding Table.





### **2.3. Acronym Definitions**

This document uses the following acronyms:

6BBR: 6LoWPAN Backbone Router

6LBR: 6LoWPAN Border Router

6LN: 6LoWPAN Node

6LR: 6LoWPAN Router

6CIO: Capability Indication Option

ARO: Address Registration Option

DAC: Duplicate Address Confirmation

DAD: Duplicate Address Detection

DAR: Duplicate Address Request

EDAC: Extended Duplicate Address Confirmation

EDAR: Extended Duplicate Address Request

DODAG: Destination-Oriented Directed Acyclic Graph

LLN: Low-Power and Lossy Network

NA: Neighbor Advertisement

NCE: Neighbor Cache Entry

ND: Neighbor Discovery

NDP: Neighbor Discovery Protocol

NS: Neighbor Solicitation

ROVR: Registration Ownership Verifier

RPL: IPv6 Routing Protocol for LLNs

RA: Router Advertisement

RS: Router Solicitation



TID: Transaction ID

**2.4. References**

In this document, readers will encounter terms and concepts that are discussed in the following documents:

- o "Neighbor Discovery for IP version 6" [[RFC4861](#)], "IPv6 Stateless Address Autoconfiguration" [[RFC4862](#)] and "Optimistic Duplicate Address Detection" [[RFC4429](#)],
- o "Neighbor Discovery Proxies (proxy-ND)" [[RFC4389](#)] and "MultiLink Subnet Issues" [[RFC4903](#)],
- o "Problem Statement and Requirements for IPv6 over Low-Power Wireless Personal Area Network (6LoWPAN) Routing" [[RFC6606](#)], and
- o Neighbor Discovery Optimization for Low-Power and Lossy Networks [[RFC6775](#)] and "Registration Extensions for 6LoWPAN Neighbor Discovery" [[RFC8505](#)].

**3. Overview**

Figure 1 illustrates backbone link federating a collection of LLNs as a single IPv6 Subnet, with a number of 6BBRs providing proxy-ND services to their attached LLNs.

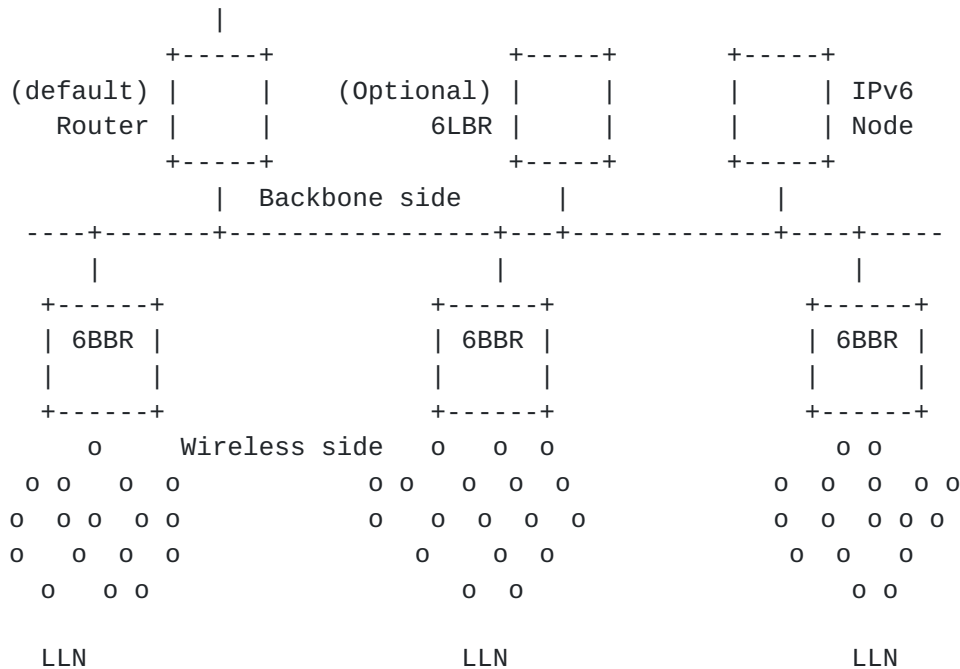

Figure 1: Backbone Link and Backbone Routers



The LLN may be a hub-and-spoke access link such as (Low-Power) IEEE STD. 802.11 (Wi-Fi) [[IEEEstd80211](#)] and IEEE STD. 802.15.1 (Bluetooth) [[IEEEstd802151](#)], or a Mesh-Under or a Route-Over network [[RFC8505](#)]. The proxy state can be distributed across multiple 6BBRs attached to the same Backbone.

The main features of a 6BBR are as follows:

- o Multilink-subnet functions (provided by the 6BBR on the backbone) performed on behalf of registered 6LNs, and
- o Routing registrar services that reduce multicast within the LLN:
  - \* Binding Table management
  - \* failover, e.g., due to mobility

Each Backbone Router (6BBR) maintains a data structure for its Registered Nodes called a Binding Table. The combined Binding Tables of all the 6BBRs on a backbone form a distributed database of 6LNs that reside in the LLNs or on the IPv6 Backbone.

Unless otherwise configured, a 6BBR does the following:

- o Create a new entry in a Binding Table for a new Registered Address and ensure that the Address is not duplicated over the Backbone
- o Defend a Registered Address over the Backbone using NA messages on behalf of the sleeping 6LN
- o Advertise a Registered Address over the Backbone using NA messages, asynchronously or as a response to a Neighbor Solicitation messages.
- o Deliver packets arriving from the LLN, using Neighbor Solicitation messages to look up the destination over the Backbone.
- o Forward or bridge packets between the LLN and the Backbone.
- o Verify liveness for a registration, when needed.

The first of these functions enables the 6BBR to fulfill its role as a Routing Registrar for each of its attached LLNs. The remaining functions fulfill the role of the 6BBRs as the border routers connecting the Multi-link IPv6 subnet to the Internet.

The proxy-ND operation can co-exist with IPv6 ND over the Backbone.



The 6BBR may co-exist with a proprietary snooping or a traditional bridging functionality in an Access Point, in order to support legacy nodes that do not support this specification. In the case, the co-existing function may turn multicasts into a series of unicast to the legacy nodes.

The registration to a proxy service uses an NS/NA(EARO) exchange. The 6BBR operation resembles that of a Mobile IPv6 (MIPv6) [[RFC6275](#)] Home Agent (HA). The combination of a 6BBR and a MIPv6 HA enables full mobility support for 6LNs, inside and outside the links that form the subnet.

The 6BBRs use the Extended Address Registration Option (EARO) defined in [[RFC8505](#)] as follows:

- o The EARO is used in the IPv6 ND exchanges over the Backbone between the 6BBRs to help distinguish duplication from movement. Extended Duplicate Address Messages (EDAR and EDAC) MAY also be used with a 6LBR, if one is present, and the 6BBR. Address duplication is detected using the ROVR field. Conflicting registrations to different 6BBRs for the same Registered Address are resolved using the TID field.
- o The Link Layer Address (LLA) that the 6BBR advertises for the Registered Address on behalf of the Registered Node over the Backbone can belong to the Registering Node; in that case, the 6BBR (acting as a Bridging Proxy (see [Section 8](#))) bridges the unicast packets. Alternatively, the LLA can be that of the 6BBR on the Backbone interface, in which case the 6BBR (acting as a Routing Proxy (see [Section 7](#))) receives the unicast packets at Layer-3 and routes over.

### **[3.1. Updating \[RFC 6775\]\(#\) and \[RFC 8505\]\(#\)](#)**

This specification adds the EARO as a possible option in RS, NS(DAD) and NA messages over the backbone. [[RFC8505](#)] requires that the registration NS(EARO) contains an SLLAO. This specification details the use of those messages over the backbone.

Note: [[RFC6775](#)] requires that the registration NS(EARO) contains an SLLAO and [[RFC4862](#)] that the NS(DAD) is sent from the unspecified address for which there cannot be a SLLAO. Consequently, an NS(DAD) cannot be confused with a registration.

This specification adds the capability to insert IPv6 ND options in the EDAR and EDAC messages. In particular, a 6BBR acting as a 6LR for the Registered Address can insert an SLLAO in the EDAR to the 6LBR in order to avoid a Lookup back. This enables the 6LBR to store





the MAC address associated to the Registered Address on a Link and to serve as a mapping server as described in [\[I-D.thubert-6lo-unicast-lookup\]](#).

### **3.2. Access Link**

Figure 2 illustrates a flow where 6LN forms an IPv6 Address and registers it to a 6BBR acting as a 6LR [\[RFC8505\]](#). The 6BBR applies ODAD (see [Section 3.6](#)) to the registered address to enable connectivity while the message flow is still in progress. In that example, a 6LBR is deployed on the backbone link to serve the whole subnet, and EDAR / EDAC messages are used in combination with DAD to enable coexistence with IPv6 ND over the backbone.



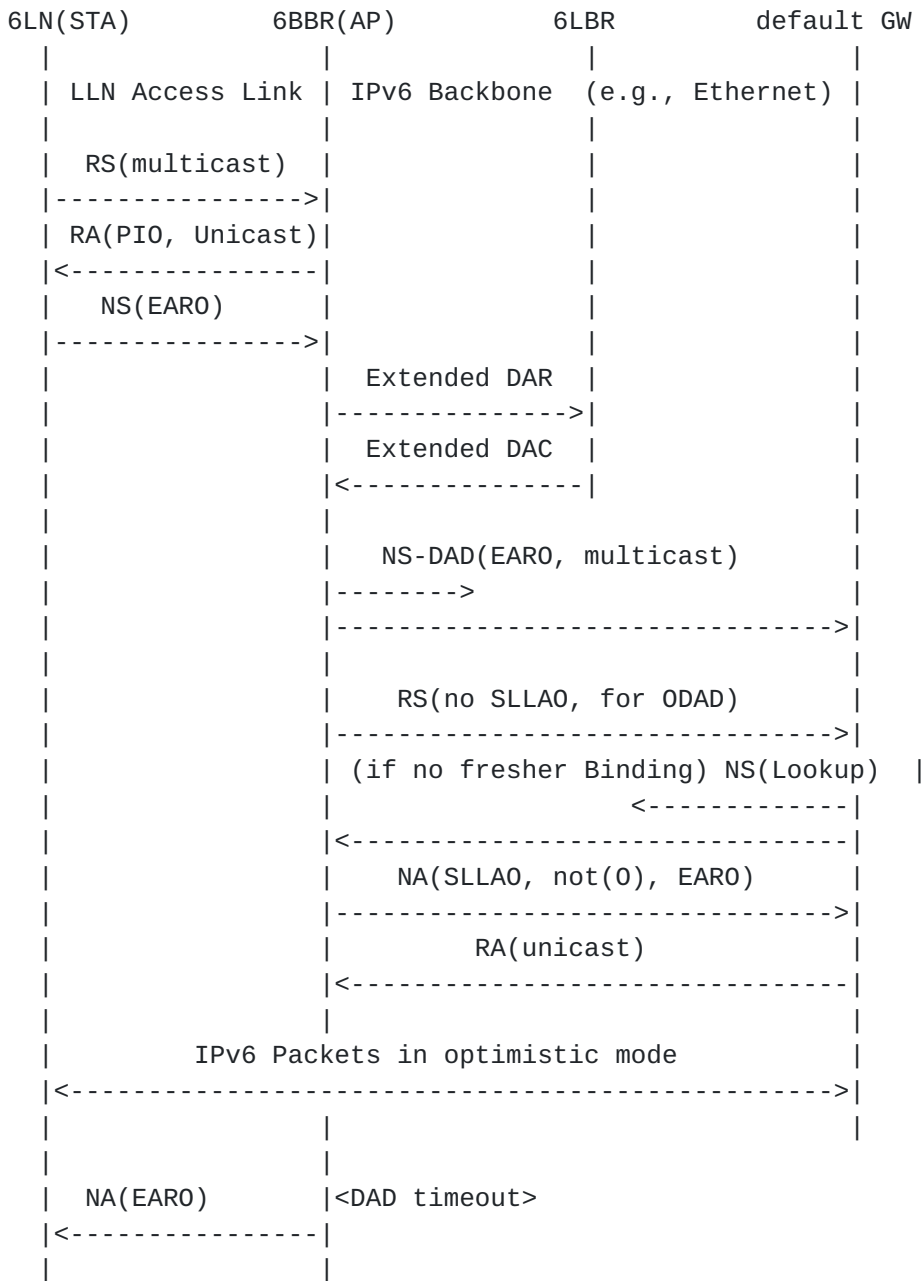

Figure 2: Initial Registration Flow to a 6BBR acting as Routing Proxy

### 3.3. Route-Over Mesh

Figure 3 illustrates IPv6 signaling that enables a 6LN to form a Global or a Unique-Local Address and register it to the 6LBR that serves its LLN using [RFC8505]. The 6LBR (acting as Registering Node) proxies the registration to the 6BBR, using [RFC8505] to register the addresses the 6LN (Registered Node) on its behalf to the 6BBR, and obtain proxy-ND services from the 6BBR.



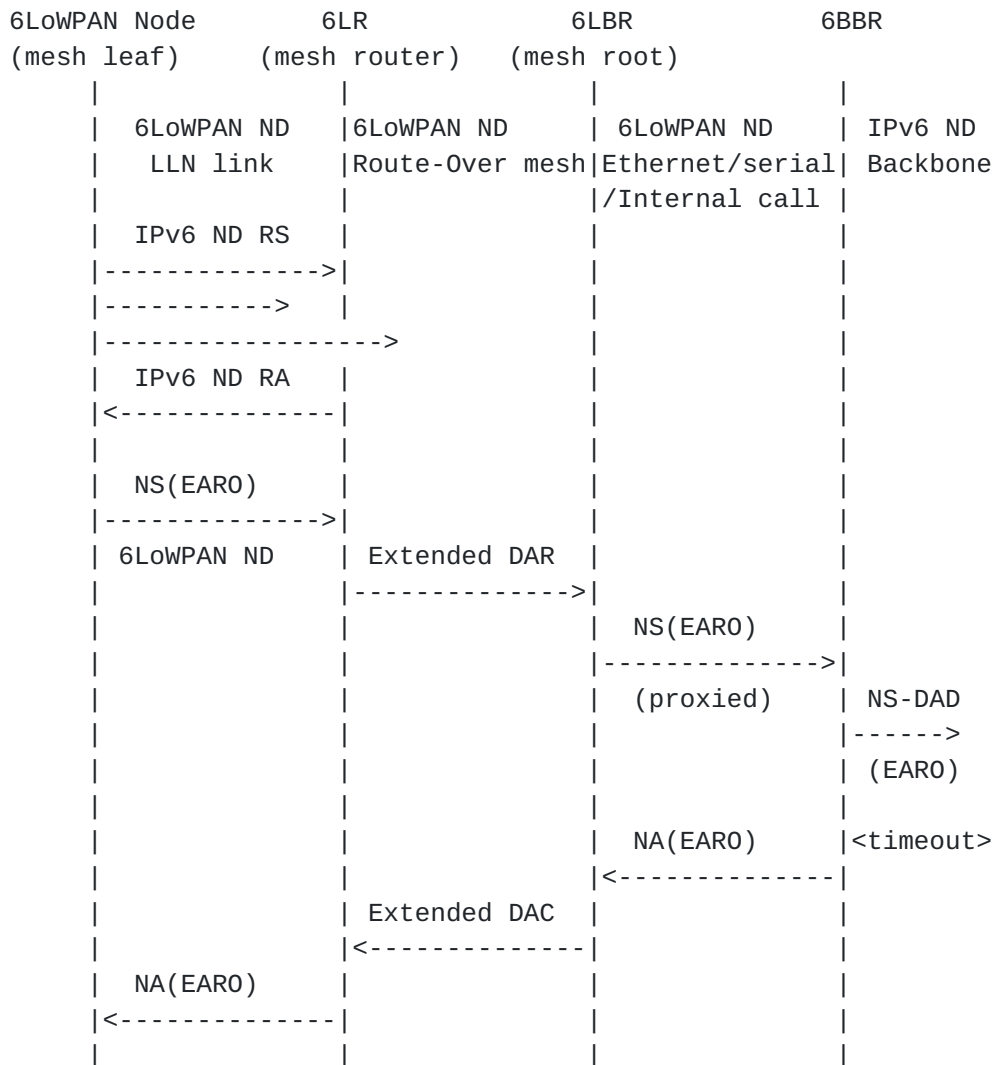

Figure 3: Initial Registration Flow over Route-Over Mesh

As a non-normative example of a Route-Over Mesh, the 6TiSCH architecture [I-D.ietf-6tisch-architecture] suggests using RPL [RFC6550] and collocating the RPL root with a 6LBR that serves the LLN, and is either collocated with or connected to the 6BBR over an IPv6 Link.

### 3.4. The Binding Table

Addresses in a LLN that are reachable from the Backbone by way of the 6BBR function must be registered to that 6BBR, using an NS(EARO) with the R flag set [RFC8505]. A 6BBR maintains a state for its active registrations in an abstract Binding Table.

An entry in the Binding Table is called a "Binding". A Binding may be in Tentative, Reachable or Stale state.



The 6BBR uses a combination of [[RFC8505](#)] and IPv6 ND over the Backbone to advertise the registration and avoid a duplication. Conflicting registrations are solved by the 6BBRs transparently to the Registering Nodes.

Only one 6LN may register a given Address, but the Address may be registered to Multiple 6BBRs for higher availability.

Over the LLN, Binding Table management is as follows:

- o De-registrations (newer TID, same ROVR, null Lifetime) are accepted with a status of 4 ("Removed"); the entry is deleted;
- o Newer registrations (newer TID, same ROVR, non-null Lifetime) are accepted with a status of 0 (Success); the Binding is updated with the new TID, the Registration Lifetime and the Registering Node; in Tentative state the EDAC response is held and may be overwritten; in other states the Registration Lifetime timer is restarted and the entry is placed in Reachable state.
- o Identical registrations (same TID, same ROVR) from a same Registering Node are accepted with a status of 0 (Success). In Tentative state, the response is held and may be overwritten, but the response MUST be eventually produced, carrying the result of the DAD process;
- o Older registrations (older TID, same ROVR) from the same Registering Node are discarded;
- o Identical and older registrations (not-newer TID, same ROVR) from a different Registering Node are rejected with a status of 3 (Moved); this may be rate limited to avoid undue interference;
- o Any registration for the same address but with a different ROVR is rejected with a status of 1 (Duplicate).

### **3.5. Primary and Secondary 6BBRs**

A same address may be successfully registered to more than one 6BBR, in which case the Registering Node uses the same EARO in all the parallel registrations. To allow for this, ND(DAD) and NA messages with an EARO that indicate an identical Binding in another 6BBR (same Registered address, same TID, same ROVR) as silently ignored.

A 6BBR MAY optionally be primary or secondary. The primary is the 6BBR that has the highest EUI-64 Address of all the 6BBRs that share a registration for the same Registered Address, with the same ROVR and same Transaction ID, the EUI-64 Address being considered as an





unsigned 64bit integer. A given 6BBR can be primary for a given Address and secondary for another Address, regardless of whether or not the Addresses belong to the same 6LN.

In the following sections, it is expected that an NA is sent over the backbone only if the node is primary or does not support the concept of primary. More than one 6BBR claiming or defending an address generates unwanted traffic but no reachability issue since all 6BBRs provide reachability from the Backbone to the 6LN.

### **3.6. Using Optimistic DAD**

Optimistic Duplicate Address Detection [[RFC4429](#)] (ODAD) specifies how an IPv6 Address can be used before completion of Duplicate Address Detection (DAD). ODAD guarantees that this behavior will not cause harm if the new Address is a duplicate.

Support for ODAD avoids delays in installing the Neighbor Cache Entry (NCE) in the 6BBRs and the default router, enabling immediate connectivity to the registered node. As shown in Figure 2, if the 6BBR is aware of the Link-Layer Address (LLA) of a router, then the 6BBR sends a Router Solicitation (RS), using the Registered Address as the IP Source Address, to the known router(s). The RS MUST be sent without a Source LLA Option (SLLAO), to avoid invalidating a preexisting NCE in the router.

Following ODAD, the router may then send a unicast RA to the Registered Address, and it may resolve that Address using an NS(Lookup) message. In response, the 6BBR sends an NA with an EARO and the Override (O) flag [[RFC4861](#)] that is not set. The router can then determine the freshest EARO in case of a conflicting NA(EARO) messages, using the method described in [section 5.2.1 of \[RFC8505\]](#). If the NA(EARO) is the freshest answer, the default router creates a Binding with the SLLAO of the 6BBR (in Routing Proxy mode) or that of the Registering Node (in Bridging Proxy mode) so that traffic from/to the Registered Address can flow immediately.

## **4. MultiLink Subnet Considerations**

The Backbone and the federated LLN Links are considered as different links in the MultiLink Subnet, even if multiple LLNs are attached to the same 6BBR. ND messages are link-scoped and are not forwarded by the 6BBR between the backbone and the LLNs though some packets may be reinjected in Bridging Proxy mode (see [Section 8](#)).

Nodes located inside the subnet do not perform the IPv6 Path MTU Discovery [[RFC8201](#)]. For that reason, the MTU must have a same value on the Backbone and all attached LLNs. To achieve this, the 6BBR



MUST use the same MTU value in RAs over the Backbone and in the RAs that it transmits towards the LLN links.

## **5. Optional 6LBR serving the MultiLink Subnet**

A 6LBR can be deployed to serve the whole MLSN. It may be attached to the backbone, in which case it can be discovered by its capability advertisement (see [section 4.3. of \[RFC8505\]](#)) in RA messages.

When a 6LBR is present, the 6BBR uses an EDAR/EDAC message exchange with the 6LBR to check for duplication or movement. This is done prior to the NS(DAD) process, which may be avoided if the 6LBR already maintains a conflicting state for the Registered Address.

This specification enables an address to be registered to more than one 6BBR. It results that a 6LBR MUST be capable to maintain a state for each of the 6BBR having registered with a same TID and same ROVR.

If this registration is duplicate or not the freshest, then the 6LBR replies with an EDAC message with a status code of 1 ("Duplicate Address") or 3 ("Moved"), respectively. If this registration is the freshest, then the 6LBR replies with a status code of 0. In that case, if this registration is fresher than an existing registration for another 6BBR, then the 6LBR also sends an asynchronous EDAC with a status of 4 ("Removed") to that other 6BBR.

The EDAC message SHOULD carry the SLLAO used in NS messages by the 6BBR for that Binding, and the EDAR message SHOULD carry the TLLAO associated with the currently accepted registration. This enables a 6BBR to locate the new position of a mobile 6LN in the case of a Routing Proxy operation, and opens the capability for the 6LBR to serve as a mapping server in the future.

Note that if Link Local addresses are registered, then the scope of uniqueness on which the address duplication is checked is the total collection of links that the 6LBR serves as opposed to the sole link on which the Link Local address is assigned.

## **6. Using IPv6 ND Over the Backbone Link**

On the Backbone side, the 6BBR MUST join the SNMA group corresponding to a Registered Address as soon as it creates a Binding for that Address, and maintain that SNMA membership as long as it maintains the registration.

The 6BBR uses either the SNMA or plain unicast to defend the Registered Addresses in its Binding Table over the Backbone (as specified in [\[RFC4862\]](#)).



The 6BBR advertises and defends the Registered Addresses over the Backbone Link using RS, NS(DAD) and NA messages with the Registered Address as the Source or Target address, respectively.

The 6BBR MUST place an EARO in the IPv6 ND messages that it generates on behalf of the Registered Node. Note that an NS(DAD) does not contain an SLLAO and cannot be confused with a proxy registration such as performed by a 6LBR.

An NA message generated in response to an NS(DAD) MUST have the Override flag set and a status of 1 (Duplicate) or 3 (Moved) in the EARO. An NA message generated in response to an NS(Lookup) or an NS(NUD) MUST NOT have the Override flag set.

This specification enables proxy operation for the IPv6 ND resolution of LLN devices and a prefix that is used across a MultiLink Subnet MAY be advertised as on-link over the Backbone. This is done for backward compatibility with existing IPv6 hosts by setting the L flag in the Prefix Information Option (PIO) of RA messages [[RFC4861](#)].

For movement involving a slow reattachment, the Neighbor Unreachability Detection (NUD) defined in [[RFC4861](#)] may time out too quickly. Nodes on the backbone SHOULD support [[RFC7048](#)] whenever possible.

## **7. Routing Proxy Operations**

A Routing Proxy provides IPv6 ND proxy functions for Global and Unique Local addresses between the LLN and the backbone, but not for Link-Local addresses. It operates as an IPv6 border router and provides a full Link-Layer isolation.

In this mode, it is not required that the MAC addresses of the 6LNs are visible at Layer-2 over the Backbone. It is thus useful when the messaging over the Backbone that is associated to wireless mobility becomes expensive, e.g., when the Layer-2 topology is virtualized over a wide area IP underlay.

This mode is definitely required when the LLN uses a MAC address format that is different from that on the Backbone (e.g., EUI-64 vs. EUI-48). Since a 6LN may not be able to resolve an arbitrary destination in the MLSN directly, the MLSN prefix MUST NOT be advertised as on-link in RA messages sent towards the LLN.

In order to maintain IP connectivity, the 6BBR installs a connected Host route to the Registered Address on the LLN interface, via the Registering Node as identified by the Source Address and the SLLA option in the NS(EARO) messages.



When operating as a Routing Proxy, the 6BBR MUST use its Layer-2 Address on its Backbone Interface in the SLLAO of the RS messages and the TLLAO of the NA messages that it generates to advertise the Registered Addresses.

For each Registered Address, multiple peers on the Backbone may have resolved the Address with the 6BBR MAC Address, maintaining that mapping in their Neighbor Cache. The 6BBR SHOULD maintain a list of the peers on the Backbone which have associated its MAC Address with the Registered Address. If that Registered Address moves to a new 6BBR, the previous 6BBR SHOULD unicast a gratuitous NA with the Override flag set to each such peer, to supply the LLA of the new 6BBR in the TLLA option for the Address. A 6BBR that does not maintain this list MAY multicast a gratuitous NA with the Override flag; this NA will possibly hit all the nodes on the Backbone, whether or not they maintain an NCE for the Registered Address.

If a correspondent fails to receive the gratuitous NA, it will keep sending traffic to a 6BBR to which the node was previously registered. Since the previous 6BBR removed its Host route to the Registered Address, it will look up the address over the backbone, resolve the address with the LLA of the new 6BBR, and forward the packet to the correct 6BBR. The previous 6BBR SHOULD also issue a redirect message [[RFC4861](#)] to update the cache of the correspondent.

## **8. Bridging Proxy Operations**

A Bridging Proxy provides IPV6 ND proxy functions between the LLN and the backbone while preserving the forwarding continuity at the MAC Layer. It acts as a Layer-2 Bridge for all types unicast packets including link-scoped, and appears as an IPV6 Host on the Backbone.

The Bridging Proxy registers any Binding including for a Link-Local address to the 6LBR (if present) and defends it over the backbone in IPV6 ND procedures.

To achieve this, the Bridging Proxy intercepts the IPV6 ND messages and may reinject them on the other side, respond directly or drop them. For instance, an ND(Lookup) from the backbone that matches a Binding can be responded directly, or turned into a unicast on the LLN side to let the 6LN respond.

As a Bridging Proxy, the 6BBR MUST use the Registering Node's Layer-2 Address in the SLLAO of the NS/RS messages and the TLLAO of the NA messages that it generates to advertise the Registered Addresses. The Registering Node's Layer-2 address is found in the SLLA of the registration NS(EARO), and maintained in the Binding Table.





The MultiLink Subnet prefix SHOULD NOT be advertised as on-link in RA messages sent towards the LLN. If a destination address is seen as on-link, then a 6LN may use NS(Lookup) messages to resolve that address. In that case, the 6BBR MUST either answer directly to the NS(Lookup) message or reinject the message on the backbone, either as a Layer-2 unicast or a multicast.

If the Registering Node owns the Registered Address, then its mobility does not impact existing NCEs over the Backbone. Otherwise, when the 6LN selects another Registering Node, the new Registering Node SHOULD send a multicast NA with the Override flag set to fix the existing NCEs across the Backbone. This method can fail if the multicast message is not received; one or more correspondent nodes on the Backbone might maintain a stale NCE, and packets to the Registered Address may be lost. When this condition happens, it is eventually discovered and resolved using Neighbor Unreachability Detection (NUD) as defined in [[RFC4861](#)].

## 9. Creating and Maintaining a Binding

Upon receiving a registration for a new Address (i.e., an NS(EARO) with the R flag set), the 6BBR creates a Binding and operates as a 6LR according to [[RFC8505](#)], interacting with the 6LBR if one is present.

An implementation of a Routing Proxy that creates a Binding MUST also create an associated Host route pointing on the registering node in the LLN interface from which the registration was received.

The 6LR operation is modified as follows:

- o EDAR and EDAC messages SHOULD carry a SLLAO and a TLLAO, respectively.
- o A Bridging Proxy MAY register Link Local addresses to the 6BBR and proxy ND for those addresses over the backbone.
- o An EDAC message with a status of 9 (6LBR Registry Saturated) is assimilated as a status of 0 if a following DAD process protects the address against duplication.

This specification enables nodes on a Backbone Link to co-exist along with nodes implementing IPv6 ND [[RFC4861](#)] as well as other non-normative specifications such as [[I-D.bi-savi-wlan](#)]. It is possible that not all IPv6 addresses on the Backbone are registered and known to the 6LBR, and an EDAR/EDAC exchange with the 6LBR might succeed even for a duplicate address. Consequently, and unless



administratively overridden, the 6BBR still needs to perform IPv6 ND DAD over the backbone after an EDAC with a status code of 0 or 9.

For the DAD operation, the Binding is placed in Tentative state for a duration of TENTATIVE\_DURATION, and an NS(DAD) message is sent as a multicast message over the Backbone to the SNMA associated with the registered Address [[RFC4862](#)]. The EARO from the registration MUST be placed unchanged in the NS(DAD) message.

If a registration is received for an existing Binding with a non-null Registration Lifetime and the registration is fresher (same ROVR, fresher TID), then the Binding is updated, with the new Registration Lifetime, TID, and possibly Registering Node. In Tentative state (see [Section 9.1](#)), the current DAD operation continues as it was. In other states (see [Section 9.2](#) and [Section 9.3](#)), the Binding is placed in Reachable state for the Registration Lifetime, and the 6BBR returns an NA(EARO) to the Registering Node with a status of 0 (Success).

Upon a registration that is identical (same ROVR, TID, and Registering Node), the 6BBR returns an NA(EARO) back to the Registering Node with a status of 0 (Success). A registration that is not as fresh (same ROVR, older TID) is ignored.

If a registration is received for an existing Binding and a registration Lifetime of zero, then the Binding is removed, and the 6BBR returns an NA(EARO) back to the Registering Node with a status of 0 (Success). An implementation of a Routing Proxy that removes a binding MUST remove the associated Host route pointing on the registering node. It MAY preserve a temporary state in order to forward packets in flight. The state may be a NCE formed based on a received NA message, or a Binding in Stale state and pointing at the new 6BBR on the backbone.

The implementation should also use REDIRECT messages as specified in [[RFC4861](#)] to update the correspondents for the Registered Address, pointing the new 6BBR.

### **[9.1](#). Operation on a Binding in Tentative State**

The Tentative state covers a DAD period over the backbone during which an address being registered is checked for duplication using procedures defined in [[RFC4862](#)].

For a Binding in Tentative state:

- o The Binding MUST be removed if an NA message is received over the Backbone for the Registered Address with no EARO, or containing an



EARO with a status of 1 (Duplicate) that indicates an existing registration owned by a different Registering Node. In that case, an NA MUST be sent back to the Registering Node with a status of 1 (Duplicate) in the EARO. This behavior might be overridden by policy, in particular if the registration is trusted, e.g., based on the validation of the ROVR field (see [[I-D.ietf-6lo-ap-nd](#)]).

- o An NS(DAD) with no EARO or with an EARO that indicates a duplicate registration (i.e. different ROVR) MUST be answered with an NA message containing an EARO with a status of 1 (Duplicate) and the Override flag not set. This behavior might be overridden by policy, in particular if the registration is not trusted.
- o The Binding MUST be removed if an NA message is received over the Backbone for the Registered Address containing an EARO with a status of 3 (Moved), or an NS(DAD) with an EARO that indicates a fresher registration ([\[RFC8505\]](#)) for the same Registered Node (i.e. same ROVR). A status of 3 is returned in the NA(EARO) back to the Registering Node.
- o NS(DAD) and NA messages containing an EARO that indicates a registration for the same Registered Node that is not as fresh as this SHOULD be answered with an NA message containing an EARO with a status of 3 (Moved) in order to clean up the situation immediately.
- o Other NS(DAD) and NA messages from the Backbone are ignored.
- o NS(Lookup) and NS(NUD) messages SHOULD be optimistically answered with an NA message containing an EARO with a status of 0 and the Override flag not set (see [Section 3.6](#)). If optimistic DAD is disabled, then they SHOULD be queued to be answered when the Binding goes to Reachable state.

When the TENTATIVE\_DURATION timer elapses, the Binding is placed in Reachable state for the Registration Lifetime, and the 6BBR returns an NA(EARO) to the Registering Node with a status of 0 (Success).

The 6BBR also attempts to take over any existing Binding from other 6BBRs and to update existing NCEs in backbone nodes. This is done by sending an NA message with an EARO and the Override flag set over the backbone (see [Section 7](#) and [Section 8](#)).

## **[9.2.](#) Operation on a Binding in Reachable State**

The Reachable state covers an active registration after a successful DAD process.



An NS(DAD) with no EARO or with an EARO that indicates a duplicate If the Registration Lifetime is of a long duration, an implementation might be configured to reassess the availability of the Registering Node at a lower period, using a NUD procedure as specified in [\[RFC7048\]](#). If the NUD procedure fails, the Binding SHOULD be placed in Stale state immediately.

For a Binding in Reachable state:

- o The Binding MUST be removed if an NA or an NS(DAD) message is received over the Backbone for the Registered Address containing an EARO that indicates a fresher registration ([\[RFC8505\]](#)) for the same Registered Node (i.e. same ROVR). A status of 4 (Removed) is returned in an asynchronous NA(EARO) to the Registering Node. Based on configuration, an implementation may delay this operation by a small timer in order to allow for a parallel registration to arrive to this node, in which case the NA might be ignored.
- o An NS(DAD) with no EARO or with an EARO that indicates a duplicate registration (i.e. different ROVR) MUST be answered with an NA message containing an EARO with a status of 1 (Duplicate) and the Override flag not set.
- o NS(DAD) and NA messages containing an EARO that indicates a registration for the same Registered Node that is not as fresh as this MUST be answered with an NA message containing an EARO with a status of 3 (Moved).
- o Other NS(DAD) and NA messages from the Backbone are ignored.
- o NS(Lookup) and NS(NUD) messages SHOULD be answered with an NA message containing an EARO with a status of 0 and the Override flag not set. The 6BBR MAY check whether the Registering Node is still available using a NUD procedure over the LLN prior to answering; this behaviour depends on the use case and is subject to configuration.

When the Registration Lifetime timer elapses, the Binding is placed in Stale state for a duration of STALE\_DURATION.

### **[9.3.](#) Operation on a Binding in Stale State**

The Stale state enables tracking of the Backbone peers that have a NCE pointing to this 6BBR in case the Registered Address shows up later.

If the Registered Address is claimed by another 6LN on the Backbone, with an NS(DAD) or an NA, the 6BBR does not defend the Address.





For a Binding in Stale state:

- o The Binding MUST be removed if an NA or an NS(DAD) message is received over the Backbone for the Registered Address containing no EARO or an EARO that indicates either a fresher registration for the same Registered Node or a duplicate registration. A status of 4 (Removed) MAY be returned in an asynchronous NA(EARO) to the Registering Node.
- o NS(DAD) and NA messages containing an EARO that indicates a registration for the same Registered Node that is not as fresh as this MUST be answered with an NA message containing an EARO with a status of 3 (Moved).
- o If the 6BBR receives an NS(Lookup) or an NS(NUD) message for the Registered Address, the 6BBR MUST attempt a NUD procedure as specified in [[RFC7048](#)] to the Registering Node, targeting the Registered Address, prior to answering. If the NUD procedure succeeds, the operation in Reachable state applies. If the NUD fails, the 6BBR refrains from answering.
- o Other NS(DAD) and NA messages from the Backbone are ignored.

When the STALE\_DURATION timer elapses, the Binding MUST be removed.

## **10. Registering Node Considerations**

A Registering Node MUST implement [[RFC8505](#)] in order to interact with a 6BBR (which acts as a routing registrar). Following [[RFC8505](#)], the Registering Node signals that it requires IPv6 proxy-ND services from a 6BBR by registering the corresponding IPv6 Address using an NS(EARO) message with the R flag set.

The Registering Node may be the 6LN owning the IPv6 Address, or a 6LBR that performs the registration on its behalf in a Route-Over mesh.

The Registering Node SHOULD register all of its IPv6 Addresses to its 6LR, which is the 6BBR when they are connected at Layer-2. Failure to register an address may result in the address being unreachable by other parties if the 6BBR cancels the NS(Lookup) over the LLN or to selected LLN nodes that are known to register their addresses.

The Registering Node MUST refrain from using multicast NS(Lookup) when the destination is not known as on-link, e.g., if the prefix is advertised in a PIO with the L flag that is not set. In that case, the Registering Node sends its packets directly to its 6LR.



The Registering Node SHOULD also follow [[RFC7772](#)] in order to limit the use of multicast RAs. It SHOULD also implement Simple Procedures for Detecting Network Attachment in IPv6 [[RFC6059](#)] (DNA procedures) to detect movements, and support Packet-Loss Resiliency for Router Solicitations [[RFC7559](#)] in order to improve reliability for the unicast RS messages.

## **11. Security Considerations**

This specification applies to LLNs in which the link layer is protected, either by means of physical or IP security for the Backbone Link or MAC-layer security. In particular, the LLN MAC is required to provide secure unicast to/from the Backbone Router and secure Broadcast from the Backbone Router in a way that prevents tampering with or replaying the RA messages.

A possible attack over the backbone can be done by sending an NS with an EARO and expecting the NA(EARO) back to contain the TID and ROVR fields of the existing state. With that information, the attacker can easily increase the TID and take over the Binding. [[I-D.ietf-6lo-ap-nd](#)] guarantees the ownership of a registered address based on a proof-of-ownership encoded in the ROVR field and protects against address theft and impersonation.

## **12. Protocol Constants**

This Specification uses the following constants:

TENTATIVE\_DURATION:           800 milliseconds

STALE\_DURATION:                see below

In LLNs with long-lived Addresses such as LPWANs, STALE\_DURATION SHOULD be configured with a relatively long value, by default 24 hours. In LLNs where addresses are renewed rapidly, e.g. for privacy reasons, STALE\_DURATION SHOULD be configured with a relatively long value, by default 5 minutes.

## **13. IANA Considerations**

This document has no request to IANA.

## **14. Acknowledgments**

Many thanks to Dorothy Stanley, Thomas Watteyne and Jerome Henry for their various contributions.



## **15. References**

### **15.1. Normative References**

- [RFC2119] Bradner, S., "Key words for use in RFCs to Indicate Requirement Levels", [BCP 14](#), [RFC 2119](#), DOI 10.17487/RFC2119, March 1997, <<https://www.rfc-editor.org/info/rfc2119>>.
- [RFC4291] Hinden, R. and S. Deering, "IP Version 6 Addressing Architecture", [RFC 4291](#), DOI 10.17487/RFC4291, February 2006, <<https://www.rfc-editor.org/info/rfc4291>>.
- [RFC4429] Moore, N., "Optimistic Duplicate Address Detection (DAD) for IPv6", [RFC 4429](#), DOI 10.17487/RFC4429, April 2006, <<https://www.rfc-editor.org/info/rfc4429>>.
- [RFC4861] Narten, T., Nordmark, E., Simpson, W., and H. Soliman, "Neighbor Discovery for IP version 6 (IPv6)", [RFC 4861](#), DOI 10.17487/RFC4861, September 2007, <<https://www.rfc-editor.org/info/rfc4861>>.
- [RFC4862] Thomson, S., Narten, T., and T. Jinmei, "IPv6 Stateless Address Autoconfiguration", [RFC 4862](#), DOI 10.17487/RFC4862, September 2007, <<https://www.rfc-editor.org/info/rfc4862>>.
- [RFC6059] Krishnan, S. and G. Daley, "Simple Procedures for Detecting Network Attachment in IPv6", [RFC 6059](#), DOI 10.17487/RFC6059, November 2010, <<https://www.rfc-editor.org/info/rfc6059>>.
- [RFC6550] Winter, T., Ed., Thubert, P., Ed., Brandt, A., Hui, J., Kelsey, R., Levis, P., Pister, K., Struik, R., Vasseur, JP., and R. Alexander, "RPL: IPv6 Routing Protocol for Low-Power and Lossy Networks", [RFC 6550](#), DOI 10.17487/RFC6550, March 2012, <<https://www.rfc-editor.org/info/rfc6550>>.
- [RFC6775] Shelby, Z., Ed., Chakrabarti, S., Nordmark, E., and C. Bormann, "Neighbor Discovery Optimization for IPv6 over Low-Power Wireless Personal Area Networks (6LoWPANs)", [RFC 6775](#), DOI 10.17487/RFC6775, November 2012, <<https://www.rfc-editor.org/info/rfc6775>>.



- [RFC7048] Nordmark, E. and I. Gashinsky, "Neighbor Unreachability Detection Is Too Impatient", [RFC 7048](#), DOI 10.17487/RFC7048, January 2014, <<https://www.rfc-editor.org/info/rfc7048>>.
- [RFC8174] Leiba, B., "Ambiguity of Uppercase vs Lowercase in [RFC 2119](#) Key Words", [BCP 14](#), [RFC 8174](#), DOI 10.17487/RFC8174, May 2017, <<https://www.rfc-editor.org/info/rfc8174>>.
- [RFC8200] Deering, S. and R. Hinden, "Internet Protocol, Version 6 (IPv6) Specification", STD 86, [RFC 8200](#), DOI 10.17487/RFC8200, July 2017, <<https://www.rfc-editor.org/info/rfc8200>>.
- [RFC8201] McCann, J., Deering, S., Mogul, J., and R. Hinden, Ed., "Path MTU Discovery for IP version 6", STD 87, [RFC 8201](#), DOI 10.17487/RFC8201, July 2017, <<https://www.rfc-editor.org/info/rfc8201>>.
- [RFC8505] Thubert, P., Ed., Nordmark, E., Chakrabarti, S., and C. Perkins, "Registration Extensions for IPv6 over Low-Power Wireless Personal Area Network (6LoWPAN) Neighbor Discovery", [RFC 8505](#), DOI 10.17487/RFC8505, November 2018, <<https://www.rfc-editor.org/info/rfc8505>>.

## **15.2. Informative References**

- [I-D.bi-savi-wlan]  
Bi, J., Wu, J., Wang, Y., and T. Lin, "A SAVI Solution for WLAN", [draft-bi-savi-wlan-16](#) (work in progress), November 2018.
- [I-D.ietf-6lo-ap-nd]  
Thubert, P., Sethi, M., Struik, R., and B. Sarikaya, "Address Protected Neighbor Discovery for Low-power and Lossy Networks", [draft-ietf-6lo-ap-nd-09](#) (work in progress), December 2018.
- [I-D.ietf-6man-rs-refresh]  
Nordmark, E., Yourtchenko, A., and S. Krishnan, "IPv6 Neighbor Discovery Optional RS/RA Refresh", [draft-ietf-6man-rs-refresh-02](#) (work in progress), October 2016.
- [I-D.ietf-6tisch-architecture]  
Thubert, P., "An Architecture for IPv6 over the TSCH mode of IEEE 802.15.4", [draft-ietf-6tisch-architecture-19](#) (work in progress), December 2018.





[I-D.ietf-mboned-ieee802-mcast-problems]

Perkins, C., McBride, M., Stanley, D., Kumari, W., and J. Zuniga, "Multicast Considerations over IEEE 802 Wireless Media", [draft-ietf-mboned-ieee802-mcast-problems-04](#) (work in progress), November 2018.

[I-D.nordmark-6man-dad-approaches]

Nordmark, E., "Possible approaches to make DAD more robust and/or efficient", [draft-nordmark-6man-dad-approaches-02](#) (work in progress), October 2015.

[I-D.thubert-6lo-unicast-lookup]

Thubert, P. and E. Levy-Abegnoli, "IPv6 Neighbor Discovery Unicast Lookup", [draft-thubert-6lo-unicast-lookup-00](#) (work in progress), January 2019.

[I-D.yourtchenko-6man-dad-issues]

Yourtchenko, A. and E. Nordmark, "A survey of issues related to IPv6 Duplicate Address Detection", [draft-yourtchenko-6man-dad-issues-01](#) (work in progress), March 2015.

[IEEEstd8021]

IEEE standard for Information Technology, "IEEE Standard for Information technology -- Telecommunications and information exchange between systems Local and metropolitan area networks Part 1: Bridging and Architecture".

[IEEEstd80211]

IEEE standard for Information Technology, "IEEE Standard for Information technology -- Telecommunications and information exchange between systems Local and metropolitan area networks-- Specific requirements Part 11: Wireless LAN Medium Access Control (MAC) and Physical Layer (PHY) Specifications".

[IEEEstd802151]

IEEE standard for Information Technology, "IEEE Standard for Information Technology - Telecommunications and Information Exchange Between Systems - Local and Metropolitan Area Networks - Specific Requirements. - Part 15.1: Wireless Medium Access Control (MAC) and Physical Layer (PHY) Specifications for Wireless Personal Area Networks (WPANs)".



- [IEEEstd802154] IEEE standard for Information Technology, "IEEE Standard for Local and metropolitan area networks -- Part 15.4: Low-Rate Wireless Personal Area Networks (LR-WPANs)".
- [RFC4389] Thaler, D., Talwar, M., and C. Patel, "Neighbor Discovery Proxies (ND Proxy)", [RFC 4389](#), DOI 10.17487/RFC4389, April 2006, <<https://www.rfc-editor.org/info/rfc4389>>.
- [RFC4903] Thaler, D., "Multi-Link Subnet Issues", [RFC 4903](#), DOI 10.17487/RFC4903, June 2007, <<https://www.rfc-editor.org/info/rfc4903>>.
- [RFC5415] Calhoun, P., Ed., Montemurro, M., Ed., and D. Stanley, Ed., "Control And Provisioning of Wireless Access Points (CAPWAP) Protocol Specification", [RFC 5415](#), DOI 10.17487/RFC5415, March 2009, <<https://www.rfc-editor.org/info/rfc5415>>.
- [RFC6275] Perkins, C., Ed., Johnson, D., and J. Arkko, "Mobility Support in IPv6", [RFC 6275](#), DOI 10.17487/RFC6275, July 2011, <<https://www.rfc-editor.org/info/rfc6275>>.
- [RFC6606] Kim, E., Kaspar, D., Gomez, C., and C. Bormann, "Problem Statement and Requirements for IPv6 over Low-Power Wireless Personal Area Network (6LoWPAN) Routing", [RFC 6606](#), DOI 10.17487/RFC6606, May 2012, <<https://www.rfc-editor.org/info/rfc6606>>.
- [RFC6830] Farinacci, D., Fuller, V., Meyer, D., and D. Lewis, "The Locator/ID Separation Protocol (LISP)", [RFC 6830](#), DOI 10.17487/RFC6830, January 2013, <<https://www.rfc-editor.org/info/rfc6830>>.
- [RFC7559] Krishnan, S., Anipko, D., and D. Thaler, "Packet-Loss Resiliency for Router Solicitations", [RFC 7559](#), DOI 10.17487/RFC7559, May 2015, <<https://www.rfc-editor.org/info/rfc7559>>.
- [RFC7772] Yourtchenko, A. and L. Colitti, "Reducing Energy Consumption of Router Advertisements", [BCP 202](#), [RFC 7772](#), DOI 10.17487/RFC7772, February 2016, <<https://www.rfc-editor.org/info/rfc7772>>.
- [RFC8273] Brzozowski, J. and G. Van de Velde, "Unique IPv6 Prefix per Host", [RFC 8273](#), DOI 10.17487/RFC8273, December 2017, <<https://www.rfc-editor.org/info/rfc8273>>.



## [Appendix A](#). Possible Future Extensions

With the current specification, the 6LBR is not leveraged to avoid multicast NS(Lookup) on the Backbone. This could be done by adding a lookup procedure in the EDAR/EDAC exchange.

By default the specification does not have a trust model, e.g., whereby nodes that associate their address with a proof-of-ownership [[I-D.ietf-6lo-ap-nd](#)] should be more trusted than nodes that do not. Such a trust model and related signaling could be added in the future to override the default operation and favor trusted nodes.

Future documents may extend this specification by allowing the 6BBR to redistribute Host routes in routing protocols that would operate over the Backbone, or in MIPv6, or FMIP, or the Locator/ID Separation Protocol (LISP) [[RFC6830](#)] to support mobility on behalf of the 6LNs, etc... LISP may also be used to provide an equivalent to the EDAR/EDAC exchange using a Map Server / Map Resolver as a replacement to the 6LBR.

## [Appendix B](#). Applicability and Requirements Served

This document specifies proxy-ND functions that can be used to federate an IPv6 Backbone Link and multiple IPv6 LLNs into a single MultiLink Subnet. The proxy-ND functions enable IPv6 ND services for Duplicate Address Detection (DAD) and Address Lookup that do not require broadcasts over the LLNs.

The term LLN is used to cover multiple types of WLANs and WPANs, including (Low-Power) Wi-Fi, BLUETOOTH(R) Low Energy, IEEE STD 802.11ah and IEEE STD.802.15.4 wireless meshes, meeting the requirements listed in [Appendix B.3 of \[RFC8505\]](#) "Requirements Related to Various Low-Power Link Types".

Each LLN in the subnet is attached at an IPv6 Backbone Router (6BBR). The Backbone Routers interconnect the LLNs and advertise the Addresses of the 6LNs over the Backbone Link using proxy-ND operations.

This specification updates IPv6 ND over the Backbone to distinguish Address movement from duplication and eliminate stale state in the Backbone routers and Backbone nodes once a 6LN has roamed. In this way, mobile nodes may roam rapidly from one 6BBR to the next and requirements in [Appendix B.1 of \[RFC8505\]](#) "Requirements Related to Mobility" are met.

A 6LN can register its IPv6 Addresses and thereby obtain proxy-ND services over the Backbone, meeting the requirements expressed in



[Appendix B.4 of \[RFC8505\]](#), "Requirements Related to Proxy Operations".

The IPv6 ND operation is minimized as the number of 6LNs grows in the LLN. This meets the requirements in [Appendix B.6 of \[RFC8505\]](#) "Requirements Related to Scalability", as long as the 6BBRs are dimensioned for the number of registrations that each needs to support.

In the case of a Wi-Fi access link, a 6BBR may be collocated with the Access Point (AP), or with a Fabric Edge (FE) or a CAPWAP [\[RFC5415\]](#) Wireless LAN Controller (WLC). In those cases, the wireless client (STA) is the 6LN that makes use of [\[RFC8505\]](#) to register its IPv6 Address(es) to the 6BBR acting as Routing Registrar. The 6LBR can be centralized and either connected to the Backbone Link or reachable over IP. The 6BBR proxy-ND operations eliminate the need for wireless nodes to respond synchronously when a Lookup is performed for their IPv6 Addresses. This provides the function of a Sleep Proxy for ND [\[I-D.nordmark-6man-dad-approaches\]](#).

For the TimeSlotted Channel Hopping (TSCH) mode of [\[IEEEstd802154\]](#), the 6TiSCH architecture [\[I-D.ietf-6tisch-architecture\]](#) describes how a 6LOWPAN ND host could connect to the Internet via a RPL mesh Network, but doing so requires extensions to the 6LOWPAN ND protocol to support mobility and reachability in a secure and manageable environment. The extensions detailed in this document also work for the 6TiSCH architecture, serving the requirements listed in [Appendix B.2 of \[RFC8505\]](#) "Requirements Related to Routing Protocols".

The registration mechanism may be seen as a more reliable alternate to snooping [\[I-D.bi-savi-wlan\]](#). It can be noted that registration and snooping are not mutually exclusive. Snooping may be used in conjunction with the registration for nodes that do not register their IPv6 Addresses. The 6BBR assumes that if a node registers at least one IPv6 Address to it, then the node registers all of its Addresses to the 6BBR. With this assumption, the 6BBR can possibly cancel all undesirable multicast NS messages that would otherwise have been delivered to that node.

Scalability of the MultiLink Subnet [\[RFC4903\]](#) requires avoidance of multicast/broadcast operations as much as possible even on the Backbone [\[I-D.ietf-mboned-ieee802-mcast-problems\]](#). Although hosts can connect to the Backbone using IPv6 ND operations, multicast RAs can be saved by using [\[I-D.ietf-6man-rs-refresh\]](#), which also requires the support of [\[RFC7559\]](#).





Authors' Addresses

Pascal Thubert (editor)  
Cisco Systems, Inc  
Building D  
45 Allee des Ormes - BP1200  
MOUGINS - Sophia Antipolis 06254  
FRANCE

Phone: +33 497 23 26 34  
Email: pthubert@cisco.com

Charles E. Perkins  
Futurewei  
2330 Central Expressway  
Santa Clara 95050  
United States of America

Email: charliep@computer.org

Eric Levy-Abegnoli  
Cisco Systems, Inc  
Building D  
45 Allee des Ormes - BP1200  
MOUGINS - Sophia Antipolis 06254  
FRANCE

Phone: +33 497 23 26 20  
Email: elevyabe@cisco.com

