

6Lo Working Group  
Internet-Draft  
Intended status: Standards Track  
Expires: September 22, 2016

Y-G. Hong  
Y-H. Choi  
ETRI  
J-S. Youn  
DONG-EUI Univ  
D-K. Kim  
KNU  
J-H. Choi  
Samsung Electronics Co.,  
March 21, 2016

**Transmission of IPv6 Packets over Near Field Communication  
draft-ietf-6lo-nfc-03**

Abstract

Near field communication (NFC) is a set of standards for smartphones and portable devices to establish radio communication with each other by touching them together or bringing them into proximity, usually no more than 10 cm. NFC standards cover communications protocols and data exchange formats, and are based on existing radio-frequency identification (RFID) standards including ISO/IEC 14443 and FeliCa. The standards include ISO/IEC 18092 and those defined by the NFC Forum. The NFC technology has been widely implemented and available in mobile phones, laptop computers, and many other devices. This document describes how IPv6 is transmitted over NFC using 6LowPAN techniques.

Status of This Memo

This Internet-Draft is submitted in full conformance with the provisions of [BCP 78](#) and [BCP 79](#).

Internet-Drafts are working documents of the Internet Engineering Task Force (IETF). Note that other groups may also distribute working documents as Internet-Drafts. The list of current Internet-Drafts is at <http://datatracker.ietf.org/drafts/current/>.

Internet-Drafts are draft documents valid for a maximum of six months and may be updated, replaced, or obsoleted by other documents at any time. It is inappropriate to use Internet-Drafts as reference material or to cite them other than as "work in progress."

This Internet-Draft will expire on September 22, 2016.

Copyright Notice

Copyright (c) 2016 IETF Trust and the persons identified as the document authors. All rights reserved.

This document is subject to BCP 78 and the IETF Trust's Legal Provisions Relating to IETF Documents (http://trustee.ietf.org/license-info) in effect on the date of publication of this document. Please review these documents carefully, as they describe your rights and restrictions with respect to this document. Code Components extracted from this document must include Simplified BSD License text as described in Section 4.e of the Trust Legal Provisions and are provided without warranty as described in the Simplified BSD License.

Table of Contents

- 1. Introduction . . . . . 3
- 2. Conventions and Terminology . . . . . 4
- 3. Overview of Near Field Communication Technology . . . . . 4
  - 3.1. Peer-to-peer Mode of NFC . . . . . 4
  - 3.2. Protocol Stacks of NFC . . . . . 5
  - 3.3. NFC-enabled Device Addressing . . . . . 6
  - 3.4. NFC MAC PDU Size and MTU . . . . . 6
- 4. Specification of IPv6 over NFC . . . . . 8
  - 4.1. Protocol Stacks . . . . . 8
  - 4.2. Link Model . . . . . 9
  - 4.3. Stateless Address Autoconfiguration . . . . . 10
  - 4.4. IPv6 Link Local Address . . . . . 10
  - 4.5. Neighbor Discovery . . . . . 11
  - 4.6. Dispatch Header . . . . . 11
  - 4.7. Header Compression . . . . . 12
  - 4.8. Fragmentation and Reassembly . . . . . 12
  - 4.9. Unicast Address Mapping . . . . . 13
  - 4.10. Multicast Address Mapping . . . . . 13
- 5. Internet Connectivity Scenarios . . . . . 14
  - 5.1. NFC-enabled Device Connected to the Internet . . . . . 14
  - 5.2. Isolated NFC-enabled Device Network . . . . . 15
- 6. IANA Considerations . . . . . 15
- 7. Security Considerations . . . . . 15
- 8. Acknowledgements . . . . . 16
- 9. References . . . . . 16
  - 9.1. Normative References . . . . . 16
  - 9.2. Informative References . . . . . 17
- Authors' Addresses . . . . . 17



## **1. Introduction**

NFC is a set of short-range wireless technologies, typically requiring a distance of 10 cm or less. NFC operates at 13.56 MHz on ISO/IEC 18000-3 air interface and at rates ranging from 106 kbit/s to 424 kbit/s. NFC always involves an initiator and a target; the initiator actively generates an RF field that can power a passive target. This enables NFC targets to take very simple form factors such as tags, stickers, key fobs, or cards that do not require batteries. NFC peer-to-peer communication is possible, provided both devices are powered. NFC builds upon RFID systems by allowing two-way communication between endpoints, where earlier systems such as contactless smart cards were one-way only. It has been used in devices such as mobile phones, running Android operating system, named with a feature called "Android Beam". In addition, it is expected for the other mobile phones, running the other operating systems (e.g., iOS, etc.) to be equipped with NFC technology in the near future.

Considering the potential for exponential growth in the number of heterogeneous air interface technologies, NFC would be widely used as one of the other air interface technologies, such as Bluetooth Low Energy (BT-LE), Wi-Fi, and so on. Each of the heterogeneous air interface technologies has its own characteristics, which cannot be covered by the other technologies, so various kinds of air interface technologies would be existing together. Therefore, it is required for them to communicate each other. NFC also has the strongest point (e.g., secure communication distance of 10 cm) to prevent the third party from attacking privacy.

When the number of devices and things having different air interface technologies communicate each other, IPv6 is an ideal internet protocols owing to its large address space. Also, NFC would be one of the endpoints using IPv6. Therefore, This document describes how IPv6 is transmitted over NFC using 6LoWPAN techniques with following scopes.

- o Overview of NFC technologies;
- o Specifications for IPv6 over NFC;
  - \* Neighbor Discovery;
  - \* Addressing and Configuration;
  - \* Header Compression;
  - \* Fragmentation & Reassembly for a IPv6 datagram;



[RFC4944](#) [1] specifies the transmission of IPv6 over IEEE 802.15.4. The NFC link also has similar characteristics to that of IEEE 802.15.4. Many of the mechanisms defined in the [RFC4944](#) [1] can be applied to the transmission of IPv6 on NFC links. This document specifies the details of IPv6 transmission over NFC links.

## **2. Conventions and Terminology**

The key words "MUST", "MUST NOT", "REQUIRED", "SHALL", "SHALL NOT", "SHOULD", "SHOULD NOT", "RECOMMENDED", "MAY", and "OPTIONAL" in this document are to be interpreted as described in [2].

## **3. Overview of Near Field Communication Technology**

NFC technology enables simple and safe two-way interactions between electronic devices, allowing consumers to perform contactless transactions, access digital content, and connect electronic devices with a single touch. NFC complements many popular consumer level wireless technologies, by utilizing the key elements in existing standards for contactless card technology (ISO/IEC 14443 A&B and JIS-X 6319-4). NFC can be compatible with existing contactless card infrastructure and it enables a consumer to utilize one device across different systems.

Extending the capability of contactless card technology, NFC also enables devices to share information at a distance that is less than 10 cm with a maximum communication speed of 424 kbps. Users can share business cards, make transactions, access information from a smart poster or provide credentials for access control systems with a simple touch.

NFC's bidirectional communication ability is ideal for establishing connections with other technologies by the simplicity of touch. In addition to the easy connection and quick transactions, simple data sharing is also available.

### **3.1. Peer-to-peer Mode of NFC**

NFC-enabled devices are unique in that they can support three modes of operation: card emulation, peer-to-peer, and reader/writer. Peer-to-peer mode enables two NFC-enabled devices to communicate with each other to exchange information and share files, so that users of NFC-enabled devices can quickly share contact information and other files with a touch. Therefore, a NFC-enabled device can securely send IPv6 packets to any corresponding node on the Internet when a NFC-enabled gateway is linked to the Internet.



### 3.2. Protocol Stacks of NFC

The IP protocol can use the services provided by Logical Link Control Protocol (LLCP) in the NFC stack to provide reliable, two-way transport of information between the peer devices. Figure 1 depicts the NFC P2P protocol stack with IPv6 bindings to the LLCP.

For data communication in IPv6 over NFC, an IPv6 packet SHALL be received at LLCP of NFC and transported to an Information Field in Protocol Data Unit (I PDU) of LLCP of the NFC-enabled peer device. Since LLCP does not support fragmentation and reassembly, upper layers SHOULD support fragmentation and reassembly. For IPv6 addressing or address configuration, LLCP SHALL provide related information, such as link layer addresses, to its upper layer. LLCP to IPv6 protocol Binding SHALL transfer the SSAP and DSAP value to the IPv6 over NFC protocol. SSAP stands for Source Service Access Point, which is 6-bit value meaning a kind of Logical Link Control (LLC) address, while DSAP means a LLC address of destination NFC-enabled device.

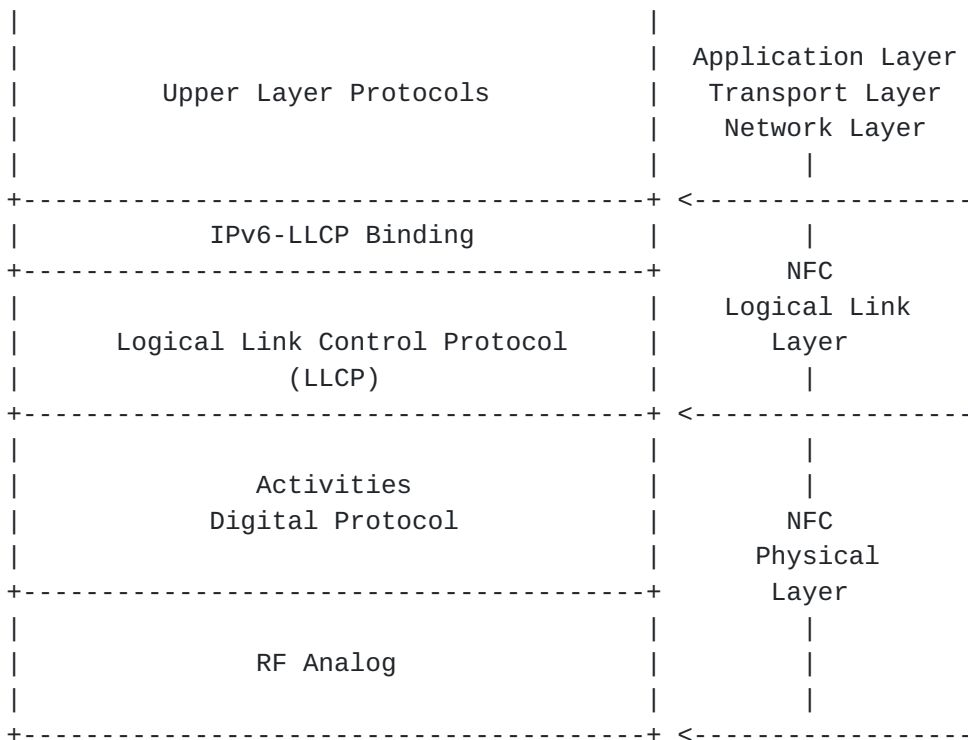

Figure 1: Protocol Stacks of NFC

The LLCP consists of Logical Link Control (LLC) and MAC Mapping. The MAC Mapping integrates an existing RF protocol into the LLCP architecture. The LLC contains three components, such as Link Management, Connection-oriented Transport, and Connection-less





Transport. The Link Management component is responsible for serializing all connection-oriented and connectionless LLC PDU (Protocol Data Unit) exchanges and for aggregation and disaggregation of small PDUs. This component also guarantees asynchronous balanced mode communication and provides link status supervision by performing the symmetry procedure. The Connection-oriented Transport component is responsible for maintaining all connection-oriented data exchanges including connection set-up and termination. The Connectionless Transport component is responsible for handling unacknowledged data exchanges.

**3.3. NFC-enabled Device Addressing**

NFC-enabled devices are identified by 6-bit LLC address. In other words, Any address SHALL be usable as both an SSAP and a DSAP address. According to NFCForum-TS-LLCP\_1.1 [3], address values between 0 and 31 (00h - 1Fh) SHALL be reserved for well-known service access points for Service Discovery Protocol (SDP). Address values between 32 and 63 (20h - 3Fh) inclusively, SHALL be assigned by the local LLC as the result of an upper layer service request.

**3.4. NFC MAC PDU Size and MTU**

As mentioned in Section 3.2, an IPv6 packet SHALL be received at LLC of NFC and transported to an Unnumbered Information Protocol Data Unit (UI PDU) and an Information Field in Protocol Data Unit (I PDU) of LLC of the NFC-enabled peer device. The format of the UI PDU and I PDU SHALL be as shown in Figure 2 and Figure 3.

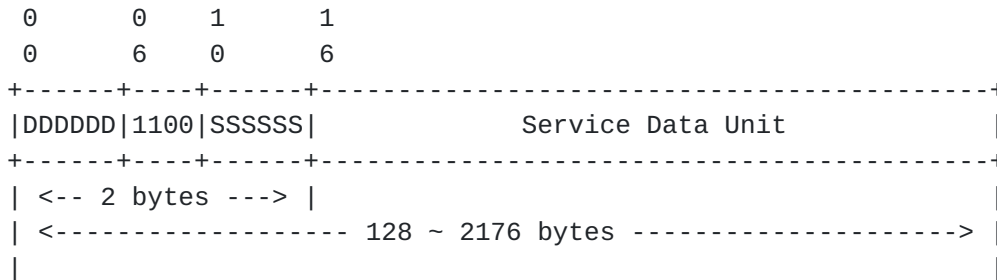

Figure 2: Format of the UI PDU in NFC



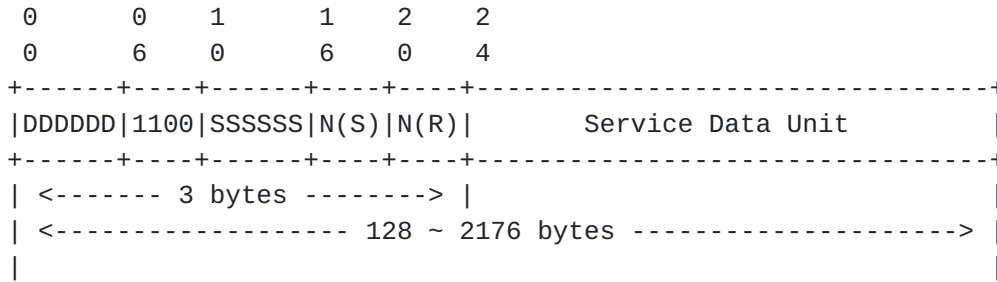

Figure 3: Format of the I PDU in NFC

The I PDU sequence field SHALL contain two sequence numbers: The send sequence number N(S) and the receive sequence number N(R). The send sequence number N(S) SHALL indicate the sequence number associated with this I PDU. The receive sequence number N(R) value SHALL indicate that I PDUs numbered up through N(R) - 1 have been received correctly by the sender of this I PDU and successfully passed to the senders SAP identified in the SSAP field. These I PDUs SHALL be considered as acknowledged.

The information field of an I PDU SHALL contain a single service data unit. The maximum number of octets in the information field SHALL be determined by the Maximum Information Unit (MIU) for the data link connection. The default value of the MIU for I PDUs SHALL be 128 octets. The local and remote LLCs each establish and maintain distinct MIU values for each data link connection endpoint. Also, An LLC MAY announce a larger MIU for a data link connection by transmitting an MIUX extension parameter within the information field. If no MIUX parameter is transmitted, the default MIU value of 128 SHALL be used. Otherwise, the MTU size in NFC LLCP SHALL calculate the MIU value as follows:

$$MIU = 128 + MIUX.$$

According to NFCForum-TS-LLCP\_1.1 [3], format of the MIUX parameter TLV is as shown in Figure 4.

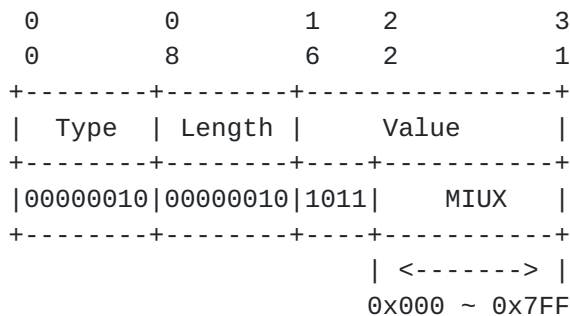

Figure 4: Format of the MIUX Parameter TLV



When the MIUX parameter is encoded as a TLV, the TLV Type field SHALL be 0x02 and the TLV Length field SHALL be 0x02. The MIUX parameter SHALL be encoded into the least significant 11 bits of the TLV Value field. The unused bits in the TLV Value field SHALL be set to zero by the sender and SHALL be ignored by the receiver. However, a maximum value of the TLV Value field can be 0x7FF, and a maximum size of the MTU in NFC LLCP SHALL calculate 2176 bytes.

#### **4. Specification of IPv6 over NFC**

NFC technology sets also has considerations and requirements owing to low power consumption and allowed protocol overhead. 6LoWPAN standards [RFC4944](#) [1], [RFC6775](#) [4], and [RFC6282](#) [5] provide useful functionality for reducing overhead which can be applied to BT-LE. This functionality comprises of link-local IPv6 addresses and stateless IPv6 address auto-configuration (see [Section 4.3](#)), Neighbor Discovery (see [Section 4.5](#)) and header compression (see [Section 4.7](#)).

One of the differences between IEEE 802.15.4 and NFC is that the former supports both star and mesh topology (and requires a routing protocol), whereas NFC can support direct peer-to-peer connection and simple mesh-like topology depending on NFC application scenarios because of very short RF distance of 10 cm or less.

##### **4.1. Protocol Stacks**

Figure 5 illustrates IPv6 over NFC. Upper layer protocols can be transport protocols (TCP and UDP), application layer, and the others capable running on the top of IPv6.



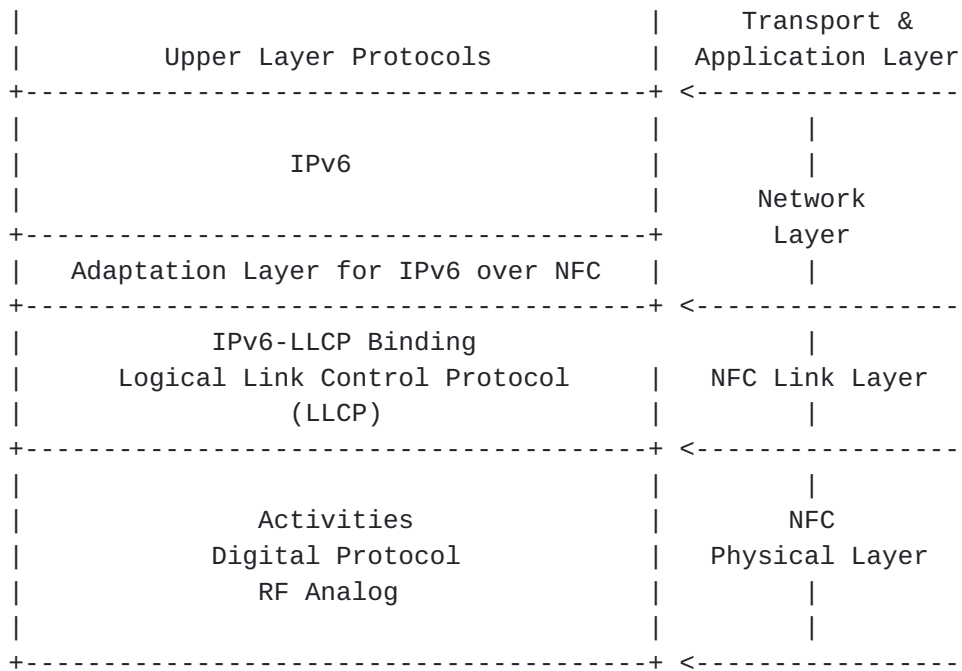

Figure 5: Protocol Stacks for IPv6 over NFC

Adaptation layer for IPv6 over NFC SHALL support neighbor discovery, address auto-configuration, header compression, and fragmentation & reassembly.

**4.2. Link Model**

In the case of BT-LE, Logical Link Control and Adaptation Protocol (L2CAP) supports fragmentation and reassembly (FAR) functionality; therefore, adaptation layer for IPv6 over BT-LE does not have to conduct the FAR procedure. The NFC LLCP, by contrast, does not support the FAR functionality, so IPv6 over NFC needs to consider the FAR functionality, defined in RFC4944 [1]. However, MTU on NFC link can be configured in a connection procedure and extended enough to fit the MTU of IPv6 packet.

The NFC link between two communicating devices is considered to be a point-to-point link only. Unlike in BT-LE, NFC link does not consider star topology and mesh network topology but peer-to-peer topology and simple multi-hop topology. Due to this characteristics, 6LoWPAN functionality, such as addressing and auto-configuration, and header compression, is specialized into NFC.





4.3. Stateless Address Autoconfiguration

A NFC-enabled device (i.e., 6LN) performs stateless address autoconfiguration as per RFC4862 [6]. A 64-bit Interface identifier (IID) for a NFC interface is formed by utilizing the 6-bit NFC LLCP address (i.e., SSAP or DSAP) (see Section 3.3). In the viewpoint of address configuration, such an IID MAY guarantee a stable IPv6 address because each data link connection is uniquely identified by the pair of DSAP and SSAP included in the header of each LLC PDU in NFC.

Following the guidance of RFC7136 [10], interface Identifiers of all unicast addresses for NFC-enabled devices are formed on the basis of 64 bits long and constructed in a modified EUI-64 format as shown in Figure 6.

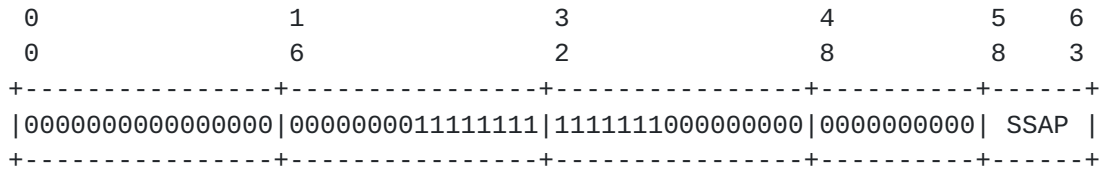

Figure 6: Formation of IID from NFC-enabled device address

In addition, the "Universal/Local" bit in the case of NFC-enabled device address MUST be set to 0 RFC4291 [7].

4.4. IPv6 Link Local Address

Only if the NFC-enabled device address is known to be a public address the "Universal/Local" bit can be set to 1. The IPv6 link-local address for a NFC-enabled device is formed by appending the IID, to the prefix FE80::/64, as depicted in Figure 7.

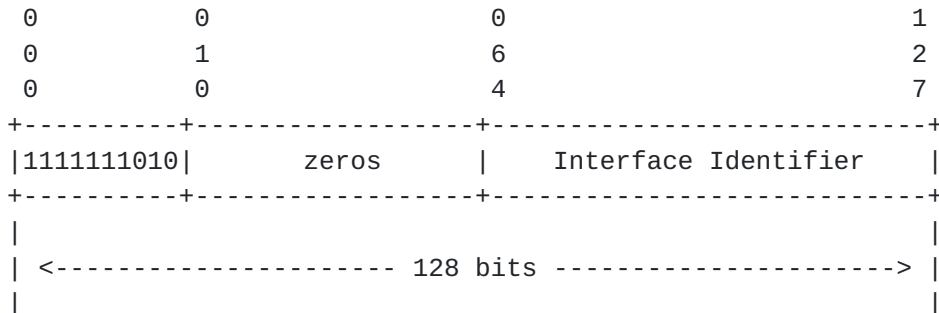

Figure 7: IPv6 link-local address in NFC



The tool for a 6LBR to obtain an IPv6 prefix for numbering the NFC network is can be accomplished via DHCPv6 Prefix Delegation ([RFC3633 \[8\]](#)).

**4.5. Neighbor Discovery**

Neighbor Discovery Optimization for 6LoWPANs ([RFC6775 \[4\]](#)) describes the neighbor discovery approach in several 6LoWPAN topologies, such as mesh topology. NFC does not consider complicated mesh topology but simple multi-hop network topology or directly connected peer-to-peer network. Therefore, the following aspects of [RFC6775](#) are applicable to NFC:

1. In a case that a NFC-enabled device (6LN) is directly connected to 6LBR, A NFC 6LN MUST register its address with the 6LBR by sending a Neighbor Solicitation (NS) message with the Address Registration Option (ARO) and process the Neighbor Advertisement (NA) accordingly. In addition, DHCPv6 is used to assigned an address, Duplicate Address Detection (DAD) is not required.
2. For sending Router Solicitations and processing Router Advertisements the NFC 6LNs MUST follow Sections [5.3](#) and [5.4](#) of the [RFC6775](#).

**4.6. Dispatch Header**

All IPv6-over-NFC encapsulated datagrams transmitted over NFC are prefixed by an encapsulation header stack consisting of a Dispatch value followed by zero or more header fields. The only sequence currently defined for IPv6-over-NFC is the LOWPAN\_IPHC header followed by payload, as depicted in Figure 8.

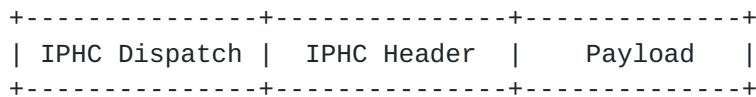

Figure 8: A IPv6-over-NFC Encapsulated 6LOWPAN\_IPHC Compressed IPv6 Datagram

The dispatch value may be treated as an unstructured namespace. Only a single pattern is used to represent current IPv6-over-NFC functionality.



```

+-----+-----+-----+
| Pattern | Header Type | Reference |
+-----+-----+-----+
| 01 1xxxx | 6LOWPAN_IPHC | [RFC6282] |
+-----+-----+-----+

```

Figure 9: Dispatch Values

Other IANA-assigned 6LowPAN Dispatch values do not apply to this specification.

**4.7. Header Compression**

Header compression as defined in RFC6282 [5] , which specifies the compression format for IPv6 datagrams on top of IEEE 802.15.4, is REQUIRED in this document as the basis for IPv6 header compression on top of NFC. All headers MUST be compressed according to RFC6282 encoding formats.

Therefore, IPv6 header compression in RFC6282 [5] MUST be implemented. Further, implementations MAY also support Generic Header Compression (GHC) of RFC7400 [11]. A node implementing GHC MUST probe its peers for GHC support before applying GHC.

If a 16-bit address is required as a short address of IEEE 802.15.4, it MUST be formed by padding the 6-bit NFC link-layer (node) address to the left with zeros as shown in Figure 10.

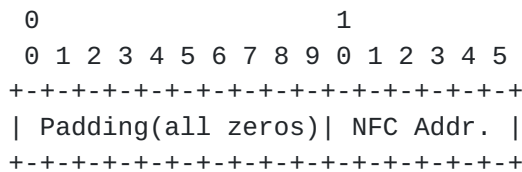

Figure 10: NFC short address format

**4.8. Fragmentation and Reassembly**

NFC provides fragmentation and reassembly (FAR) for payloads from 128 bytes up to 2176 bytes as mention in Section 3.4. The MTU of a general IPv6 packet can fit into a sigle NFC link frame. Therefore, the FAR functionality as defined in RFC4944, which specifies the fragmentation methods for IPv6 datagrams on top of IEEE 802.15.4, is NOT REQUIRED in this document as the basis for IPv6 datagram FAR on top of NFC. The NFC link connection for IPv6 over NFC MUST be configured with an equivalent MIU size to fit the MTU of IPv6 Packet. However, the default configuration of MIUX value is 0x480 in order to fit the MTU (1280 bytes) of a IPv6 packet.



**4.9. Unicast Address Mapping**

The address resolution procedure for mapping IPv6 non-multicast addresses into NFC link-layer addresses follows the general description in Section 7.2 of RFC4861 [9], unless otherwise specified.

The Source/Target link-layer Address option has the following form when the addresses are 6-bit NFC link-layer (node) addresses.

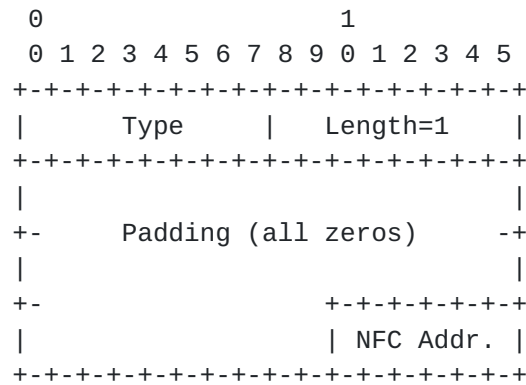

Figure 11: Unicast address mapping

Option fields:

Type:

- 1: for Source Link-layer address.
- 2: for Target Link-layer address.

Length:

This is the length of this option (including the type and length fields) in units of 8 octets. The value of this field is 1 for 6-bit NFC node addresses.

NFC address:

The 6-bit address in canonical bit order. This is the unicast address the interface currently responds to.

**4.10. Multicast Address Mapping**

All IPv6 multicast packets MUST be sent to NFC Destination Address, 0x3F (broadcast) and filtered at the IPv6 layer. When represented as a 16-bit address in a compressed header, it MUST be formed by padding





on the left with a zero. In addition, the NFC Destination Address, 0x3F, MUST not be used as a unicast NFC address of SSAP or DSAP.

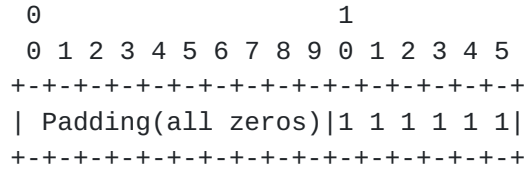

Figure 12: Multicast address mapping

5. Internet Connectivity Scenarios

As two typical scenarios, the NFC network can be isolated and connected to the Internet.

5.1. NFC-enabled Device Connected to the Internet

One of the key applications by using adaptation technology of IPv6 over NFC is the most securely transmitting IPv6 packets because RF distance between 6LN and 6LBR SHOULD be within 10 cm. If any third party wants to hack into the RF between them, it MUST come to nearly touch them. Applications can choose which kinds of air interfaces (e.g., BT-LE, Wi-Fi, NFC, etc.) to send data depending characteristics of data. NFC SHALL be the best solution for secured and private information.

Figure 13 illustrates an example of NFC-enabled device network connected to the Internet. Distance between 6LN and 6LBR SHOULD be 10 cm or less. If there is any of close laptop computers to a user, it SHALL becomes the 6LBR. Additionally, When the user mounts a NFC-enabled air interface adapter (e.g., portable small NFC dongle) on the close laptop PC, the user's NFC-enabled device (6LN) can communicate the laptop PC (6LBR) within 10 cm distance.



Figure 13: NFC-enabled device network connected to the Internet



**5.2. Isolated NFC-enabled Device Network**

In some scenarios, the NFC-enabled device network may transiently be a simple isolated network as shown in the Figure 14.

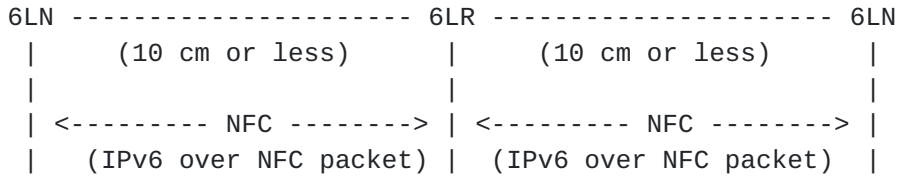

Figure 14: Isolated NFC-enabled device network

In mobile phone markets, applications are designed and made by user developers. They may image interesting applications, where three or more mobile phones touch or attach each other to accomplish outstanding performance. For instance, three or more mobile phones can play multi-channel sound of music together. In addition, attached three or more mobile phones can make an extended banner to show longer sentences in a concert hall.

**6. IANA Considerations**

There are no IANA considerations related to this document.

**7. Security Considerations**

When interface identifiers (IIDs) are generated, devices and users are required to consider mitigating various threats, such as correlation of activities over time, location tracking, device-specific vulnerability exploitation, and address scanning.

IPv6-over-NFC is, in practice, not used for long-lived links for big size data transfer or multimedia streaming, but used for extremely short-lived links (i.e., single touch-based approaches) for ID verification and mobile payment. This will mitigate the threat of correlation of activities over time.

IPv6-over-NFC uses an IPv6 interface identifier formed from a "Short Address" and a set of well-known constant bits (such as padding with '0's) for the modified EUI-64 format. However, the short address of NFC link layer (LLC) is not generated as a physically permanent value but logically generated for each connection. Thus, every single touch connection can use a different short address of NFC link with an extremely short-lived link. This can mitigate address scanning as well as location tracking and device-specific vulnerability exploitation.



However, malicious tries for one connection of a long-lived link with NFC technology are not secure, so the method of deriving interface identifiers from 6-bit NFC Link layer addresses is intended to preserve global uniqueness when it is possible. Therefore, it requires to protect from duplication through accident or forgery and to define a way to include sufficient bit of entropy in the IPv6 interface identifier, such as random EUI-64.

## 8. Acknowledgements

We are grateful to the members of the IETF 6lo working group.

Michael Richardson, Suresh Krishnan, Pascal Thubert, Carsten Bormann, and Alexandru Petrescu have provided valuable feedback for this draft.

## 9. References

### 9.1. Normative References

- [1] Montenegro, G., Kushalnagar, N., Hui, J., and D. Culler, "Transmission of IPv6 Packets over IEEE 802.15.4 Networks", RFC 4944, DOI 10.17487/RFC4944, September 2007, <<http://www.rfc-editor.org/info/rfc4944>>.
- [2] Bradner, S., "Key words for use in RFCs to Indicate Requirement Levels", BCP 14, RFC 2119, DOI 10.17487/RFC2119, March 1997, <<http://www.rfc-editor.org/info/rfc2119>>.
- [3] "Logical Link Control Protocol version 1.1", NFC Forum Technical Specification , June 2011.
- [4] Shelby, Z., Ed., Chakrabarti, S., Nordmark, E., and C. Bormann, "Neighbor Discovery Optimization for IPv6 over Low-Power Wireless Personal Area Networks (6LoWPANs)", RFC 6775, DOI 10.17487/RFC6775, November 2012, <<http://www.rfc-editor.org/info/rfc6775>>.
- [5] Hui, J., Ed. and P. Thubert, "Compression Format for IPv6 Datagrams over IEEE 802.15.4-Based Networks", RFC 6282, DOI 10.17487/RFC6282, September 2011, <<http://www.rfc-editor.org/info/rfc6282>>.
- [6] Thomson, S., Narten, T., and T. Jinmei, "IPv6 Stateless Address Autoconfiguration", RFC 4862, DOI 10.17487/RFC4862, September 2007, <<http://www.rfc-editor.org/info/rfc4862>>.



- [7] Hinden, R. and S. Deering, "IP Version 6 Addressing Architecture", [RFC 4291](#), DOI 10.17487/RFC4291, February 2006, <<http://www.rfc-editor.org/info/rfc4291>>.
- [8] Troan, O. and R. Droms, "IPv6 Prefix Options for Dynamic Host Configuration Protocol (DHCP) version 6", [RFC 3633](#), DOI 10.17487/RFC3633, December 2003, <<http://www.rfc-editor.org/info/rfc3633>>.
- [9] Narten, T., Nordmark, E., Simpson, W., and H. Soliman, "Neighbor Discovery for IP version 6 (IPv6)", [RFC 4861](#), DOI 10.17487/RFC4861, September 2007, <<http://www.rfc-editor.org/info/rfc4861>>.
- [10] Carpenter, B. and S. Jiang, "Significance of IPv6 Interface Identifiers", [RFC 7136](#), DOI 10.17487/RFC7136, February 2014, <<http://www.rfc-editor.org/info/rfc7136>>.
- [11] Bormann, C., "6LoWPAN-GHC: Generic Header Compression for IPv6 over Low-Power Wireless Personal Area Networks (6LoWPANs)", [RFC 7400](#), DOI 10.17487/RFC7400, November 2014, <<http://www.rfc-editor.org/info/rfc7400>>.

## **9.2. Informative References**

- [12] "Near Field Communication - Interface and Protocol (NFCIP-1) 3rd Ed.", ECMA-340 , June 2013.

### Authors' Addresses

Yong-Geun Hong  
ETRI  
161 Gajeong-Dong Yuseung-Gu  
Daejeon 305-700  
Korea

Phone: +82 42 860 6557  
Email: yghong@etri.re.kr

Younghwan Choi  
ETRI  
218 Gajeongno, Yuseong  
Daejeon 305-700  
Korea

Phone: +82 42 860 1429  
Email: yhc@etri.re.kr





Joo-Sang Youn  
DONG-EUI University  
176 Eomgwangno Busan\_jin\_gu  
Busan 614-714  
Korea

Phone: +82 51 890 1993  
Email: joosang.youn@gmail.com

Dongkyun Kim  
Kyungpook National University  
80 Daehak-ro, Buk-gu  
Daegu 702-701  
Korea

Phone: +82 53 950 7571  
Email: dongkyun@knu.ac.kr

JinHyouk Choi  
Samsung Electronics Co.,  
129 Samsung-ro, Youngdong-gu  
Suwon 447-712  
Korea

Phone: +82 2 2254 0114  
Email: jinchoe@samsung.com

