

BESS Workgroup  
INTERNET-DRAFT  
Intended Status: Standards Track

A. Sajassi  
P. Brissette  
Cisco  
J. Uttaro  
ATT  
J. Drake  
W. Lin  
Juniper  
S. Boutros  
VMWare  
J. Rabadan  
Nokia

Expires: December 6, 2019

June 6, 2019

EVPN VPWS Flexible Cross-Connect Service  
draft-ietf-bess-evpn-vpws-fxc-01.txt

## Abstract

This document describes a new EVPN VPWS service type specifically for multiplexing multiple attachment circuits across different Ethernet Segments and physical interfaces into a single EVPN VPWS service tunnel and still providing Single-Active and All-Active multi-homing. This new service is referred to as flexible cross-connect service. It also describes the rationale for this new service type as well as a solution to deliver such service.

## Status of this Memo

This Internet-Draft is submitted to IETF in full conformance with the provisions of [BCP 78](#) and [BCP 79](#).

Internet-Drafts are working documents of the Internet Engineering Task Force (IETF), its areas, and its working groups. Note that other groups may also distribute working documents as Internet-Drafts.

Internet-Drafts are draft documents valid for a maximum of six months and may be updated, replaced, or obsoleted by other documents at any time. It is inappropriate to use Internet-Drafts as reference material or to cite them other than as "work in progress."

The list of current Internet-Drafts can be accessed at <http://www.ietf.org/lid-abstracts.html>

INTERNET DRAFT

EVPN VPWS Flex Xconnect

June 6, 2019

The list of Internet-Draft Shadow Directories can be accessed at <http://www.ietf.org/shadow.html>

## Copyright and License Notice

Copyright (c) 2018 IETF Trust and the persons identified as the document authors. All rights reserved.

This document is subject to [BCP 78](#) and the IETF Trust's Legal Provisions Relating to IETF Documents (<http://trustee.ietf.org/license-info>) in effect on the date of publication of this document. Please review these documents carefully, as they describe your rights and restrictions with respect to this document. Code Components extracted from this document must include Simplified BSD License text as described in Section 4.e of the Trust Legal Provisions and are provided without warranty as described in the Simplified BSD License.

## Table of Contents

<a href="#">1</a>	Introduction . . . . .	<a href="#">3</a>
<a href="#">1.1</a>	Terminology . . . . .	<a href="#">3</a>
<a href="#">2</a>	Requirements . . . . .	<a href="#">4</a>
<a href="#">4</a>	Solution . . . . .	<a href="#">6</a>
<a href="#">4.1</a>	Flexible Xconnect . . . . .	<a href="#">7</a>
<a href="#">4.2</a>	VLAN-Signaled Flexible Xconnect . . . . .	<a href="#">8</a>
<a href="#">4.2.1</a>	Local Switching . . . . .	<a href="#">9</a>
<a href="#">5</a>	BGP Extensions . . . . .	<a href="#">9</a>
<a href="#">6</a>	Failure Scenarios . . . . .	<a href="#">11</a>
<a href="#">6.1</a>	EVPN VPWS service Failure . . . . .	<a href="#">13</a>
<a href="#">6.2</a>	Attachment Circuit Failure . . . . .	<a href="#">13</a>
<a href="#">6.3</a>	PE Port Failure . . . . .	<a href="#">14</a>
<a href="#">6.4</a>	PE Node Failure . . . . .	<a href="#">14</a>
<a href="#">7</a>	Security Considerations . . . . .	<a href="#">14</a>
<a href="#">8</a>	IANA Considerations . . . . .	<a href="#">14</a>
<a href="#">9</a>	References . . . . .	<a href="#">14</a>
<a href="#">9.1</a>	Normative References . . . . .	<a href="#">14</a>
<a href="#">9.2</a>	Informative References . . . . .	<a href="#">15</a>
	Authors' Addresses . . . . .	<a href="#">15</a>

INTERNET DRAFT

EVPN VPWS Flex Xconnect

June 6, 2019

## 1 Introduction

[RFC8214] describes a solution to deliver P2P services using BGP constructs defined in [RFC7432]. It delivers this P2P service between a pair of Attachment Circuits (ACs), where an AC can designate on a PE, a port, a VLAN on a port, or a group of VLANs on a port. It also leverages multi-homing and fast convergence capabilities of [RFC7432] in delivering these VPWS services. Multi-homing capabilities include the support of single-active and all-active redundancy mode and fast convergence is provided using "mass withdraw" message in control-plane and fast protection switching using prefix independent convergence in data-plane upon node or link failure [BGP-PIC]. Furthermore, the use of EVPN BGP constructs eliminates the need for multi-segment PW auto-discovery and signaling if the VPWS service need to span across multiple ASes.

Some service providers have very large number of ACs (in millions) that need to be back hauled across their MPLS/IP network. These ACs may or may not require tag manipulation (e.g., VLAN translation). These service providers want to multiplex a large number of ACs across several physical interfaces spread across one or more PEs (e.g., several Ethernet Segments) onto a single VPWS service tunnel in order to a) reduce number of EVPN service labels associated with EVPN-VPWS service tunnels and thus the associated OAM monitoring, and b) reduce EVPN BGP signaling (e.g., not to signal each AC as it is the case in [RFC8214]).

These service provider want the above functionality without scarifying any of the capabilities of [RFC8214] including single-active and all-active multi-homing, and fast convergence.

This document presents a solution based on extensions to [RFC8214] to meet the above requirements.

### 1.1 Terminology

The key words "MUST", "MUST NOT", "REQUIRED", "SHALL", "SHALL NOT", "SHOULD", "SHOULD NOT", "RECOMMENDED", "MAY", and "OPTIONAL" in this document are to be interpreted as described in [RFC 2119](#) [[RFC2119](#)].

MAC: Media Access Control

MPLS: Multi Protocol Label Switching

OAM: Operations, Administration and Maintenance

PE: Provide Edge Node

CE: Customer Edge device e.g., host or router or switch

EVPL: Ethernet Virtual Private Line

EPL: Ethernet Private Line

ES: Ethernet Segment

VPWS: Virtual private wire service

EVI: EVPN Instance

VPWS Service Tunnel: It is represented by a pair of EVPN service labels associated with a pair of endpoints. Each label is downstream assigned and advertised by the disposition PE through an Ethernet A-D per-EVI route. The downstream label identifies the endpoint on the disposition PE. A VPWS service tunnel can be associated with many VPWS service identifiers for VLAN-signaled VPWS service where each identifier is a normalized VID.

Single-Active Mode: When a device or a network is multi-homed to two or more PEs and when only a single PE in such redundancy group can forward traffic to/from the multi-homed device or network for a given VLAN, then such multi-homing or redundancy is referred to as "Single-Active".

All-Active: When a device is multi-homed to two or more PEs and when all PEs in such redundancy group can forward traffic to/from the multi-homed device for a given VLAN, then such multi-homing or

redundancy is referred to as "All-Active".

## 2 Requirements

Two of the main motivations for service providers seeking a new solution are: 1) to reduce number of VPWS service tunnels by multiplexing large number of ACs across different physical interfaces instead of having one VPWS service tunnel per AC, and 2) to reduce the signaling of ACs as much as possible. Besides these two requirements, they also want multi-homing and fast convergence capabilities of [[RFC8214](#)].

In [[RFC8214](#)], a PE signals an AC indirectly by first associating that AC to a VPWS service tunnel (e.g., a VPWS service instance) and then signaling the VPWS service tunnel via a per-EVI Ethernet AD route with Ethernet Tag field set to a 24-bit VPWS service instance identifier (which is unique within the EVI) and ESI field set to a 10-octet identifier of the Ethernet Segment corresponding to that AC.

Therefore, a PE device that receives such EVPN routes, can associate the VPWS service tunnel to the remote Ethernet Segment, and when the remote ES fails and the PE receives the "mass withdraw" message associated with the failed ES per [[RFC7432](#)], it can update its BGP path list for that VPWS service tunnel quickly and achieve fast convergence for multi-homing scenarios. Even if fast convergence were not needed, there would still be a need for signaling each AC failure (via its corresponding VPWS service tunnel) associated with the failed ES, so that the BGP path list for each of them gets updated accordingly and the packets are sent to backup PE (in case of single-active multi-homing) or to other PEs in the redundancy group (in case of all-active multi-homing). In absence of updating the BGP path list, the traffic for that VPWS service tunnel will be black-holed.

When a single VPWS service tunnel multiplexes many ACs across number of Ethernet Segments (number of physical interfaces) and the ACs are not signaled via EVPN BGP to remote PE devices, then the remote PE devices neither know the association of the received Ethernet Segment to these ACs (and in turn to their local ACs) nor they know the association of the VPWS service tunnel (e.g., EVPN service label) to the far-end ACs - i.e, the remote PEs only know the association of their local ACs to the VPWS service tunnel but not the far-end ACs.

Thus upon a connectivity failure to the ES, they don't know how to redirect traffic via another multi-homing PE to that ES. In other words, even if an ES failure is signaled via EVPN to the remote PE devices, they don't know what to do with such message because they don't know the association among the remote ES, the remote ACs, and the VPWS service tunnel.

In order to address this issue when multiplexing large number of ACs onto a single VPWS service tunnel, two mechanisms are devised: one to support VPWS services between two single-homed endpoints and another one to support VPWS services where one of the endpoints is multi-homed. An endpoint can be an AC, MAC-VRF, IP-VRF, global table, or etc.

For single-homed endpoints, it is OK not to signal each AC in BGP because upon connection failure to the ES, there is no alternative path to that endpoint. However, the ramification for not signaling an AC failure is that the traffic destined to the failed AC, is sent over MPLS/IP core and then gets discarded at the destination PE - i.e., it can waste network resources. However, when there is a connection failure, the application layer will eventually stop sending traffic and thus this wastage of network resources should be transient. [Section 4.1](#) describes a solution for such single-homing VPWS service.

For VPWS services where one of the endpoints is multi-homed, there

are two options:

1) to signal each AC via BGP so that the path list can be updated upon a failure that impacts those ACs. This solution is described in [section 4.2](#) and it is called VLAN-signaled flexible cross-connect service.

2) to bundle several ACs on an ES together per destination end-point (e.g., ES, MAC-VRF, etc.) and associated such bundle to a single VPWS service tunnel. This is similar to VLAN-bundle service interface described in [[RFC8214](#)]. This solution is described in [section 4.3](#).

This section describes a solution for providing a new VPWS service between two PE devices where a large number of ACs (e.g., VLANs) that span across many Ethernet Segments (i.e., physical interfaces) on each PE are multiplex onto a single P2P EVPN service tunnel. Since multiplexing is done across several physical interfaces, there can be overlapping VLAN IDs across these interfaces; therefore, in such scenarios, the VLAN IDs (VIDs) MUST be translated into unique VIDs to avoid collision. Furthermore, if the number of VLANs that are getting multiplex onto a single VPWS service tunnel, exceed 4K, then a single tag to double tag translation MUST be performed. This translation of VIDs into unique VIDs (either single or double) is referred to as "VID normalization". When single normalized VID is used, the lower 12-bit of Ethernet tag field in EVPN routes is set to that VID and when double normalized VID is used, the lower 12-bit of Ethernet tag field is set to inner VID and the higher 12-bit is set to the outer VID.

Since there is only a single EVPN VPWS service tunnel associated with many normalized VIDs (either single or double) across multiple physical interfaces, MPLS lookup at the disposition PE is no longer sufficient to forward the packet to the right egress endpoint/interface. Therefore, in addition to an EVPN label lookup corresponding to the VPWS service tunnel, a VID lookup (either single or double) is also required. On the disposition PE, one can think of the lookup of EVPN label results in identification of a VID-VRF, and the lookup of normalized VID(s) in that table, results in identification of egress endpoint/interface. The tag manipulation (translation from normalized VID(s) to local VID) can be performed either as part of the VID table lookup or at the egress interface itself.

Since VID lookup (single or double) needs to be performed at the

disposition PE, then VID normalization MUST be performed prior to the MPLS encapsulation on the ingress PE. This requires that both imposition and disposition PE devices be capable of VLAN tag manipulation, such as re-write (single or double), addition, deletion (single or double) at their endpoints (e.g., their ES's, MAC-VRFs, IP-VRFs, etc.).

## [4.1](#) Flexible Xconnect

In this mode of operation, many ACs across several Ethernet Segments are multiplex into a single EVPN VPWS service tunnel represented by a single VPWS service ID. This is the default mode of operation for FXC and the participating PEs do not need to signal the VLANs (normalized VIDs) in EVPN BGP.

With respect to the data-plane aspects of the solution, both imposition and disposition PEs are aware of the VLANs as the imposition PE performs VID normalization and the disposition PE does VID lookup and translation. In this solution, there is only a single P2P EVPN VPWS service tunnel between a pair of PEs for a set of ACs.

As discussed previously, since the EVPN VPWS service tunnel is used to multiplex ACs across different ES's (e.g., physical interfaces), the EVPN label alone is not sufficient for proper forwarding of the received packets (over MPLS/IP network) to egress interfaces. Therefore, normalized VID lookup is required in the disposition direction to forward packets to their proper egress end-points - i.e., the EVPN label lookup identifies a VID-VRF and subsequently, the normalized VID lookup in that table, identifies the egress interface.

This mode of operation is only suitable for single-homing because in multi-homing the association between EVPN VPWS service tunnel and remote AC changes during the failure and therefore the VLANs (normalized VIDs) need to be signaled.

In this solution, on each PE, the single-homing ACs represented by their normalized VIDs are associated with a single EVPN VPWS service tunnel (in a given EVI). The EVPN route that gets generated is an EVPN Ethernet AD per EVI route with ESI=0, Ethernet Tag field set to VPWS service instance ID, MPLS label field set to dynamically generated EVPN service label representing the EVPN VPWS service tunnel. This route is sent with an RT representing the EVI. This RT can be auto-generated from the EVI per [section 5.1.2.1](#) of [EVPN-Overlay]. Furthermore, this route is sent with the EVPN Layer-2 Extended Community defined in [section 3.1 of \[RFC8214\]](#) with two new flags (defined in [section 5](#)) that indicate: 1) this VPWS service

tunnel is for default Flexible Cross-Connect, and 2) normalized VID



type (single versus double). The receiving PE uses these new flags for consistency check and MAY generate an alarm if it detects inconsistency but doesn't bring down the VPWS service.

It should be noted that in this mode of operation, a single Ethernet AD per EVI route is sent upon configuration of the first AC (ie, normalized VID). Later, when additional ACs are configured and associated with this EVPN VPWS service tunnel, the PE does not advertise any additional EVPN BGP routes. The PE only associates locally these ACs with the already created VPWS service tunnel.

The default FXC mode can be used for multi-homing. In this mode, a group of normalized VIDs (ACs) on a single Ethernet segment that are destined to a single endpoint are multiplexed into a single EVPN VPWS service tunnel represented by a single VPWS service ID. When the default FXC mode is used for multi-homing, instead of a single EVPN VPWS service tunnel, there can be many service tunnels per pair of PEs - i.e, there is one tunnel per group of VIDs per pair of PEs and there can be many groups between a pair of PEs, thus resulting in many EVPN service tunnels.

## [4.2](#) VLAN-Signaled Flexible Xconnect

In this mode of operation, just as the default FXC mode in [section 4.1](#), many normalized VIDs (ACs) across several different ES's/interfaces are multiplexed into a single EVPN VPWS service tunnel; however, this single tunnel is represented by many VPWS service IDs (one per normalized VID) and these normalized VIDs are signaled using EVPN BGP.

In this solution, on each PE, the multi-homing ACs represented by their normalized VIDs are configured with a single EVI. There is no need to configure VPWS service instance ID in here as it is the same as the normalized VID. For each normalized VID on each ES, the PE generates an EVPN Ethernet AD per EVI route where ESI field represents the ES ID, the Ethernet Tag field is set to the normalized VID, MPLS label field is set to dynamically generated EVPN label representing the P2P EVPN service tunnel and it is the same label for all the ACs that are multiplexed into a single EVPN VPWS service tunnel. This route is sent with an RT representing the EVI. As before, this RT can be auto-generated from the EVI per [section 5.1.2.1](#) of [[EVPN-Overlay](#)]. Furthermore, this route is sent with the EVPN Layer-2 Extended Community defined in [section 3.1 of \[RFC8214\]](#) with two new flags (defined in [section 5](#)) that indicate: 1) this VPWS service tunnel is for VLAN-signaled Flexible Cross-Connect, and 2) normalized VID type (single versus double). The receiving PE uses

these new flags for consistency check and MAY generate an alarm if it detects inconsistency but doesn't bring down the VPWS service.

It should be noted that in this mode of operation, the PE sends a single Ethernet AD route for each AC that is configured - i.e., each normalized VID that is configured per ES results in generation of an EVPN Ethernet AD per EVI.

This mode of operation provides automatic cross checking of normalized VIDs used for EVPL services because these VIDs are signaled in EVPN BGP. For example, if the same normalized VID is configured on three PE devices (instead of two) for the same EVI, then when a PE receives the second EVPN EAD per-EVI route, it generates an error message unless the two EVPN EAD per-EVI routes include the same ESI. Such cross-checking is not feasible in default FXC mode because the normalized VIDs are not signaled.

#### [4.2.1](#) Local Switching

When cross-connection is between two ACs belonging to two multi-homed Ethernet Segments on the same set of multi-homing PEs, then forwarding between the two ACs MUST be performed locally during normal operation (e.g., in absence of a local link failure) - i.e., the traffic between the two ACs MUST be locally switched within the PE.

In terms of control plane processing, this means that when the receiving PE receives an Ethernet A-D per-EVI route whose ESI is a local ESI, the PE does not alter its forwarding state based on the received route. This ensures that the local switching takes precedence over forwarding via MPLS/IP network. This scheme of locally switched preference is consistent with baseline EVPN [RFC 7432] where it describes the locally switched preference for MAC/IP routes.

In such scenarios, the Ethernet A-D per EVI route should be advertised with the MPLS label either associated with the destination Attachment Circuit or with the destination Ethernet Segment in order to avoid any ambiguity in forwarding. In other words, the MPLS label cannot represent the same VID-VRF used in [section 4.2](#) because the same normalized VID can be reachable via two Ethernet Segments. In case of using MPLS label per destination AC, then this same solution can be used for VLAN-based VPWS or VLAN-bundle VPWS services per [[RFC8214](#)].

## 5. BGP Extensions

This draft uses the EVPN Layer-2 attribute extended community defined in [[RFC8214](#)] with two additional flags added to this EC as described below. This EC is to be advertised with Ethernet A-D per EVI route per [section 4](#).

```
+-----+
| Type(0x06)/Sub-type(TBD) (2 octet) |
+-----+
| Control Flags (2 octets)           |
+-----+
| L2 MTU (2 octets)                 |
+-----+
| Reserved (2 octets)                |
+-----+
```

```
 0 1 2 3 4 5 6 7 8 9 0 1 2 3 4 5
+---+---+---+---+---+---+---+---+---+---+---+---+---+---+---+
| MBZ           | V | M | C|P|B| (MBZ = MUST Be Zero)
+---+---+---+---+---+---+---+---+---+---+---+---+---+---+---
```

The following bits in the Control Flags are defined; the remaining bits MUST be set to zero when sending and MUST be ignored when receiving this community.

Name	Meaning
B,P,C	per definition in [ <a href="#">RFC8214</a> ]
M	00 mode of operation as defined in [ <a href="#">RFC8214</a> ] 01 VLAN-Signaled FXC 10 Default FXC

V           00 operating per [[RFC8214](#)]  
            01 single-VID normalization  
            10 double-VID normalization

The M and V fields are OPTIONAL on transmission and ignored at reception for forwarding purposes. They are used for error notifications.

Sajassi et al.

Expires December 6, 2019

[Page 10]

---

INTERNET DRAFT

EVPN VPWS Flex Xconnect

June 6, 2019

## [6](#) Failure Scenarios

Two examples will be used as an example to analyze the failure scenarios.

The first scenario is depicted in Figure 1 and shows the VLAN-signaled FXC mode with Multi-Homing. In this example:

- CE1 is connected to PE1 and PE2 via (port,vid)=(p1,1) and (p3,3) respectively. CE1's VIDs are normalized to value 1 on both PEs, and CE1 is Xconnected to CE3's VID 1 at the remote end.
- CE2 is connected to PE1 and PE2 via ports p2 and p4 respectively:
  - o (p2,1) and (p4,3) identify the ACs that are used to Xconnect CE2 to CE4's VID 2, and are normalized to value 2.
  - o (p2,2) and (p4,4) identify the ACs that are used to Xconnect CE2 to CE5's VID 3, and are normalized to value 3.

In this scenario, PE1 and PE2 advertise an AD per-EVI route per normalized VID (values 1, 2 and 3), however only two VPWS Service Tunnels are needed: VPWS Service Tunnel 1 (sv.T1) between PE1's FXC service and PE3's FXC, and VPWS Service Tunnel 2 (sv.T2) between PE2's FXC and PE3's FXC.

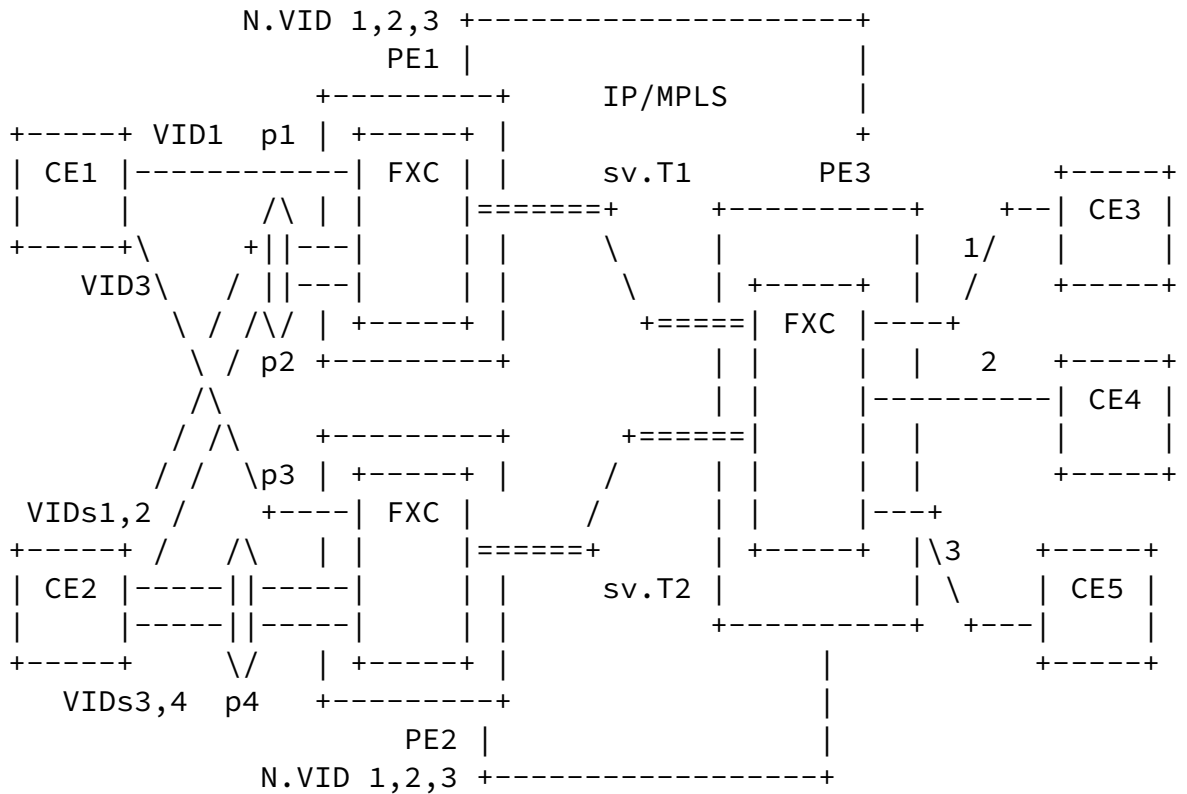
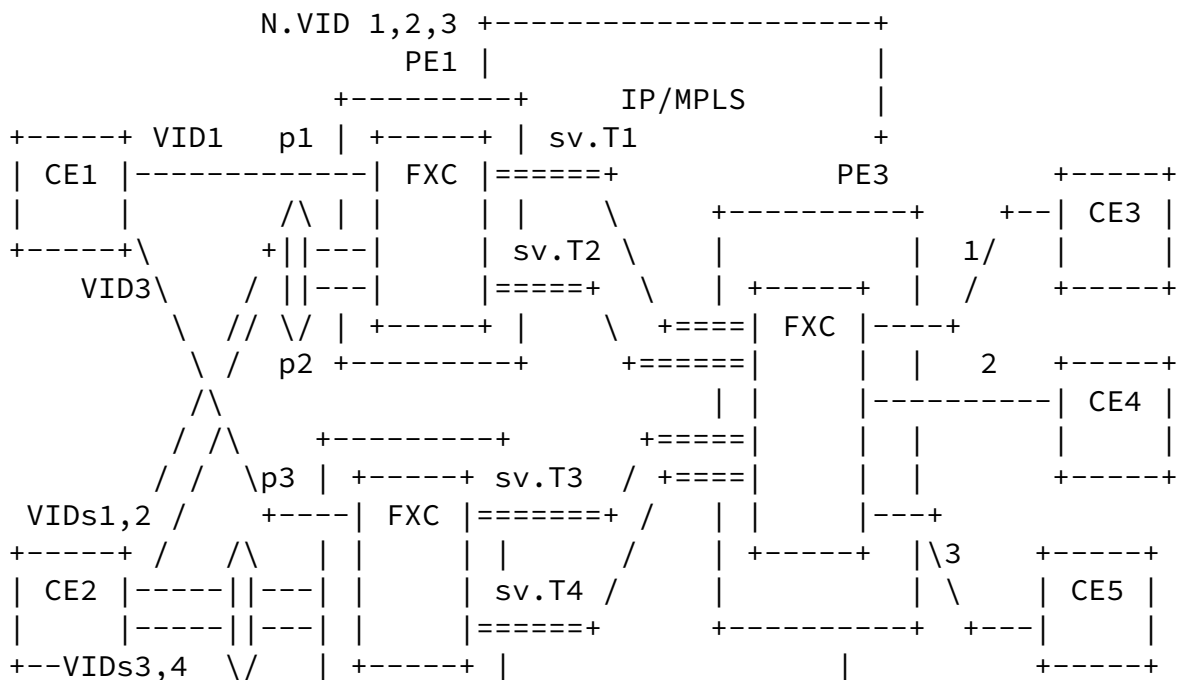

Figure 1 VLAN-Signaled Flexible Xconnect

The second scenario is a default Flexible Xconnect with Multi- Homing solution and it is depicted in Figure 2. In this case, the same VID Normalization as in the previous example is performed, however there is not an individual AD per-EVI route per normalized VID, but per bundle of ACs on an ES. That is, PE1 will advertise two AD per-EVI routes: the first one will identify the ACs on p1's ES and the second one will identify the AC2 in p2's ES. Similarly, PE2 will advertise two AD per-EVI routes.



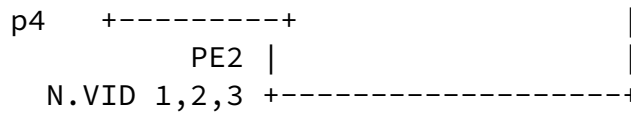

Figure 2 Default Flexible Xconnect

### 6.1 EVPN VPWS service Failure

The failure detection of an EVPN VPWS service can be performed via OAM mechanisms such as VCCV-BFD and upon such failure detection, the switch over procedure to the backup S-PE is the same as the one described above.

### 6.2 Attachment Circuit Failure

In case of AC Failure, the VLAN-Signaled and default FXC modes behave in a different way:

- o VLAN-signaled FXC (Figure 1): a VLAN or AC failure, e.g. VID1 on CE2, triggers the withdrawal of the AD per-EVI route for the corresponding Normalized VID, that is, Ethernet-Tag 2. When PE3 receives the route withdrawal, it will remove PE1 from its path-list for traffic coming from CE4.

- o Default FXC (Figure 2): a VLAN or AC failure is not signaled in the default mode, therefore in case of an AC failure, e.g. VID1 on CE2, nothing prevents PE3 from sending CE4's traffic to PE1, creating a

black-hole. Application layer OAM may be used if per-VLAN fault propagation is required in this case.

### 6.3 PE Port Failure

In case of PE port Failure, the failure will be signaled and the other PE will take over in both cases:

- o VLAN-signaled FXC (Figure 1): a port failure, e.g. p2, triggers the

withdrawal of the AD per-EVI routes for Normalized VIDs 2 and 3, as well as the withdrawal of the AD per-ES route for p2's ES. Upon receiving the fault notification, PE3 will withdraw PE1 from its path-list for the traffic coming from CE4 and CE5.

o Default FXC (Figure 2): a port failure, e.g. p2, is signaled by route for sv.T2 will also be withdrawn. Upon receiving the fault notification, PE3 will remove PE1 from its path-list for traffic coming from CE4 and CE5.

## [6.4](#) PE Node Failure

In the case of PE node failure, the operation is similar to the steps described above, albeit that EVPN route withdrawals are performed by the Route Reflector instead of the PE.

## [7](#) Security Considerations

There are no additional security considerations beyond what is already specified in [[RFC8214](#)].

## [8](#) IANA Considerations

TBD.

## [9](#) References

### [9.1](#) Normative References

[RFC2119] Bradner, S., "Key words for use in RFCs to Indicate Requirement Levels", [BCP 14](#), [RFC 2119](#), March 1997.

[RFC7432] Sajassi et al., "Ethernet VPN", [RFC 7432](#), February 2015.

Sajassi et al.

Expires December 6, 2019

[Page 14]

---

INTERNET DRAFT

EVPN VPWS Flex Xconnect

June 6, 2019

[RFC8214] Boutros et al., "Virtual Private Wire Service Support in Ethernet VPN", [RFC 8214](#), August 2015.



## 9.2 Informative References

[BGP-PIC] Bashandy A. et al., "BGP Prefix Independent Convergence", [draft-rtgwg-bgp-pic-02.txt](#), work in progress, October 2013.

[EVPN-Overlay] Sajassi et al., "A Network Virtualization Overlay Solution using EVPN", [draft-ietf-bess-evpn-overlay-12](#), work in progress, February 2018.

### Authors' Addresses

A. Sajassi  
Cisco  
EMail: [sajassi@cisco.com](mailto:sajassi@cisco.com)

P. Brissette  
Cisco  
EMail: [pbrisset@cisco.com](mailto:pbrisset@cisco.com)

J. Uttaro  
ATT  
EMail: [ju1738@att.com](mailto:ju1738@att.com)

J. Drake  
Juniper  
EMail: [jdrake@juniper.net](mailto:jdrake@juniper.net)

S. Boutros  
ATT  
EMail: [boutros.sami@gmail.com](mailto:boutros.sami@gmail.com)

INTERNET DRAFT

EVPN VPWS Flex Xconnect

June 6, 2019

W. Lin  
Juniper  
EMail: wlin@juniper.net

J. Rabadan  
jorge.rabadan@nokia.com

