

Network Working Group
Internet Draft
Updates: [3471](#)(if approved)
Category: Standards Track

Tomohiro Otani(Ed.)
KDDI
Dan Li(Ed.)
Huawei

Expires: June 2011

December 13, 2010

Generalized Labels for Lambda-Switching Capable Label Switching
Routers

[draft-ietf-ccamp-gmpls-g-694-lambda-labels-10.txt](#)

Status of this Memo

This Internet-Draft is submitted to IETF in full conformance with the provisions of [BCP 78](#) and [BCP 79](#).

Internet-Drafts are working documents of the Internet Engineering Task Force (IETF), its areas, and its working groups. Note that other groups may also distribute working documents as Internet-Drafts.

Internet-Drafts are draft documents valid for a maximum of six months and may be updated, replaced, or obsoleted by other documents at any time. It is inappropriate to use Internet-Drafts as reference material or to cite them other than as "work in progress."

The list of current Internet-Drafts can be accessed at <http://www.ietf.org/ietf/lid-abstracts.txt>

The list of Internet-Draft Shadow Directories can be accessed at <http://www.ietf.org/shadow.html>

This Internet-Draft will expire on June 13, 2011.

Copyright Notice

Copyright (c) 2010 IETF Trust and the persons identified as the document authors. All rights reserved.

This document is subject to [BCP 78](#) and the IETF Trust's Legal Provisions Relating to IETF Documents (<http://trustee.ietf.org/license-info>) in effect on the date of publication of this document. Please review these documents carefully, as they describe your rights and restrictions with respect to this document. Code Components extracted from this document must include Simplified BSD License text as described in [Section 4.e](#) of

[draft-ietf-ccamp-gmpls-g-694-lambda-labels-10.txt](#)

December 2010

the Trust Legal Provisions and are provided without warranty as described in the Simplified BSD License.

This document may contain material from IETF Documents or IETF Contributions published or made publicly available before November 10, 2008. The person(s) controlling the copyright in some of this material may not have granted the IETF Trust the right to allow modifications of such material outside the IETF Standards Process. Without obtaining an adequate license from the person(s) controlling the copyright in such materials, this document may not be modified outside the IETF Standards Process, and derivative works of it may not be created outside the IETF Standards Process, except to format it for publication as an RFC or to translate it into languages other than English.

Abstract

Technology in the optical domain is constantly evolving and as a consequence new equipment providing lambda switching capability has been developed and is currently being deployed.

Generalized MPLS (GMPLS) is a family of protocols that can be used to operate networks built from a range of technologies including wavelength (or lambda) switching. For this purpose, GMPLS defined that a wavelength label only has significance between two neighbors and global wavelength semantics are not considered.

In order to facilitate interoperability in a network composed of next generation lambda switch-capable equipment, this document defines a standard lambda label format that is compliant with Dense Wavelength Division Multiplexing and Coarse Wavelength Division Multiplexing grids defined by the International Telecommunication Union Telecommunication Standardization Sector. The label format defined in this document can be used in GMPLS signaling and routing protocols.

Conventions used in this document

The key words "MUST", "MUST NOT", "REQUIRED", "SHALL", "SHALL NOT", "SHOULD", "SHOULD NOT", "RECOMMENDED", "MAY", and "OPTIONAL" in this document are to be interpreted as described in [[RFC2119](#)].

1. Introduction

As described in [[RFC3945](#)], Generalized MPLS (GMPLS) extends MPLS from supporting only packet (Packet Switching Capable - PSC)

interfaces and switching to also include support for four new classes of interfaces and switching:

- o Layer-2 Switch Capable (L2SC)
- o Time-Division Multiplex (TDM)
- o Lambda Switch Capable (LSC)
- o Fiber-Switch Capable (FSC).

A functional description of the extensions to MPLS signaling needed to support new classes of interfaces and switching is provided in [[RFC3471](#)].

This document presents details that are specific to the use of GMPLS with Lambda Switch Capable (LSC) equipment. Technologies such as Reconfigurable Optical Add/Drop Multiplex (ROADM) and Wavelength Cross-Connect (WXC) operate at the wavelength switching level. [[RFC3471](#)] has defined that a wavelength label ([section 3.2.1.1](#)) "only has significance between two neighbors" and global wavelength semantics is not considered. In order to facilitate interoperability in a network composed of lambda switch-capable equipment, this document defines a standard lambda label format, which is compliant with both [[G.694.1](#)](Dense Wavelength Division Multiplexing (DWDM)-grid) or [[G.694.2](#)](Coarse Wavelength Division Multiplexing (CWDM)-grid).

2. Assumed Network Model and Related Problem Statement

Figure 1 depicts an all-optically switched network consisting of different vendors' optical network domains. Vendor A's network consists of ROADM or WXC, and vendor B's network consists of a number of photonic cross-connect (PXC) and DWDM multiplexer & demultiplexer, otherwise both vendors' networks might be based on the same technology.

In this case, the use of standardized wavelength label information is quite significant to establish a wavelength-based LSP. It is also an important constraint when conducting CSPF calculation for use by Generalized Multi-Protocol Label Switching (GMPLS) RSVP-TE signaling, [RFC3473]. The way the Constrained Shortest Path First (CSPF) is performed is outside the scope of this document.

It is needless to say, an LSP must be appropriately provisioned between a selected pair of ports not only within Domain A but also over multiple domains satisfying wavelength constraints.

Figure 2 illustrates in detail the interconnection between Domain A and Domain B.

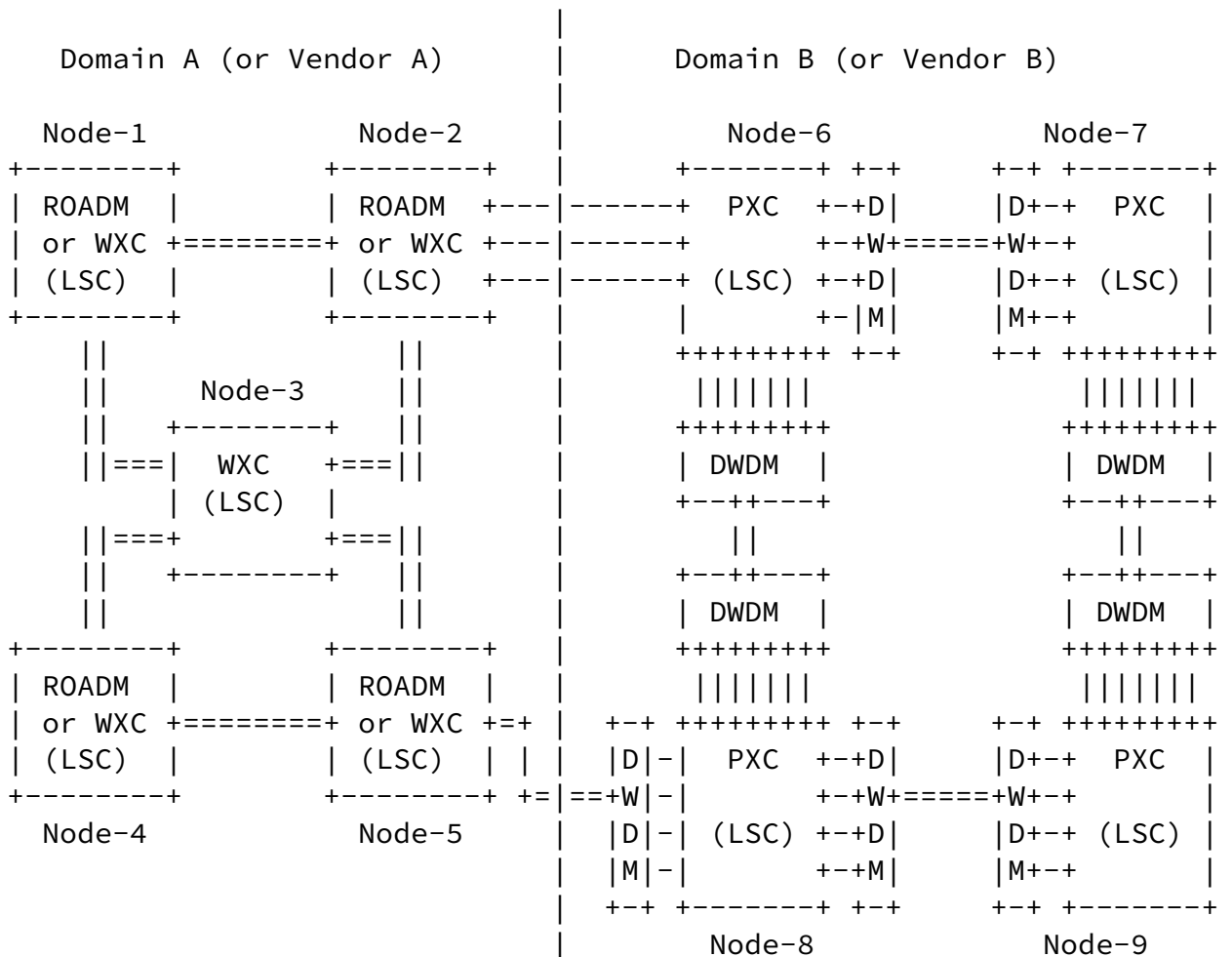

Figure 1 Wavelength-based network model

GMPLS RSVP-TE. In order to satisfy wavelength continuity constraint, a fixed wavelength (λ) needs to be used in domain A and domain B. A Path message will be used for signaling. The Path message will contain the Upstream_Label object and a Label_Set object; both containing the same value. The Label_Set object is made by only one sub channel that must be same as the Upstream_Label object. The Path setup will continue downstream to switch 9 by configuring each lambda switch based on the wavelength label. If a node has a tunable wavelength transponder, the tuning wavelength is considered as a part of wavelength switching operation.

Not using a standardized label would add undue burden on the operator to enforce policy as each manufacturer may decide on a different representation and therefore each domain may have its own label formats. Moreover, manual provisioning may lead to misconfiguration if domain-specific labels are used.

Therefore, a wavelength label should be standardized in order to allow interoperability between multiple domains; otherwise

appropriate existing labels are identified in support of wavelength availability. As identical wavelength information, the ITU-T frequency grid specified in [G.694.1] for DWDM and wavelength information in [G.694.2] for CWDM are used by Label Switching Routers (LSRs) and should be followed as a wavelength label.

3. Label Related Formats

To deal with the widening scope of MPLS into the optical and time domains, several new forms of "label" have been defined in [RFC3471]. This section contains a definition of a Wavelength label based on [G.694.1] or [G.694.2] for use by LSC LSRs.

3.1. Wavelength Labels

In [section 3.2.1.1 of \[RFC3471\]](#), a Wavelength label is defined to have significance between two neighbors, and the receiver may need to convert the received value into a value that has local significance.

We do not need to define a new type as the information stored is either a port label or a wavelength label. Only the wavelength label as below needs to be defined.

LSC equipment uses multiple wavelengths controlled by a single control channel. In a case, the label indicates the wavelength to be used for the LSP. This document defines a standardize wavelength label format. As an example of wavelength values, the reader is referred to [\[G.694.1\]](#) which lists the frequencies from the ITU-T DWDM frequency grid. The same can be done for CWDM technology by using the wavelength defined in [\[G.694.2\]](#).

Since the ITU-T DWDM grid is based on nominal central frequencies, we need to indicate the appropriate table, the channel spacing in the grid and a value n that allows the calculation of the frequency. That value can be positive or negative.

The frequency is calculated as such in [\[G.694.1\]](#):

$$\text{Frequency (THz)} = 193.1 \text{ THz} + n * \text{channel spacing (THz)}$$

Where "n" is a two's-complement integer (positive, negative or 0) and "channel spacing" is defined to be 0.0125, 0.025, 0.05 or 0.1 THz. When wider channel spacing such as 0.2 THz is utilized, the combination of narrower channel spacing and the value "n" can provide proper frequency with that channel spacing. Channel spacing is not utilized to indicate the LSR capability but only to specify a frequency in signaling.

For the other example of the case of the ITU-T CWDM grid, the spacing between different channels was defined to be 20nm, so we need to pass the wavelength value in nanometers(nm) in this case. Examples of CWDM wavelengths are 1471, 1491, etc. nm.

The wavelength is calculated as follows

$$\text{Wavelength (nm)} = 1471 \text{ nm} + n * 20 \text{ nm}$$

Where "n" is a two's-complement integer (positive, negative or 0). The grids listed in [\[G.694.1\]](#) and [\[G.694.2\]](#) are not numbered and change with the changing frequency spacing as technology advances, so an index is not appropriate in this case.

[3.2. DWDM Wavelength Label](#)

For the case of lambda switching (LSC) of DWDM, the information carried in a Wavelength label is:

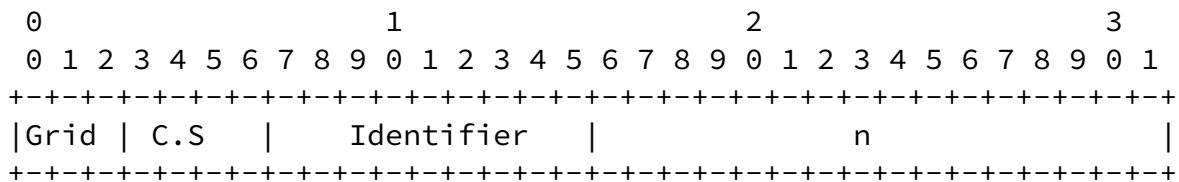

(1) Grid: 3 bits

The value for grid is set to 1 for ITU-T DWDM Grid as defined in [G.694.1].

+-----+	+-----+	+-----+		
	Grid		Value	
+-----+	+-----+	+-----+		
	Reserved		0	
+-----+	+-----+	+-----+		
	ITU-T DWDM		1	
+-----+	+-----+	+-----+		
	ITU-T CWDM		2	
+-----+	+-----+	+-----+		
	Future use		3 - 7	
+-----+	+-----+	+-----+		

(2) C.S.(channel spacing): 4 bits

DWDM channel spacing is defined as follows.

+-----+	+-----+	+-----+		
	C.S(GHz)		Value	
+-----+	+-----+	+-----+		
	Reserved		0	
+-----+	+-----+	+-----+		
	100		1	
+-----+	+-----+	+-----+		
	50		2	
+-----+	+-----+	+-----+		
	25		3	
+-----+	+-----+	+-----+		
	12.5		4	

```

+-----+-----+
|Future use| 5 - 15 |
+-----+-----+

```

(3) Identifier: 9 bits

The identifier field is a per-node assigned and scoped value. This field MAY change on a per-hop basis. In all cases but one, a node MAY select any value, including zero (0), for this field. Once selected, the value MUST NOT change until the LSP is torn down and the value MUST be used in all LSP related messages, e.g., in Resv messages and label RRO subobjects. The sole special case occurs when this label format is used in a label ERO subobject. In this case, the special value of zero (0) means that the referenced node MAY assign any Identifier field value, including zero (0), when establishing the corresponding LSP.

(4) n: 16 bits

n is a two's-complement integer to take either a negative, zero or a positive value. The value used to compute the frequency as shown above.

3.3. CWDM Wavelength Label

For the case of lambda switching (LSC) of CWDM, the information carried in a Wavelength label is:

```

      0              1              2              3
0 1 2 3 4 5 6 7 8 9 0 1 2 3 4 5 6 7 8 9 0 1 2 3 4 5 6 7 8 9 0 1
+--+--+--+--+--+--+--+--+--+--+--+--+--+--+--+--+--+--+--+--+--+
|Grid| C.S  | Identifier |                n                |
+--+--+--+--+--+--+--+--+--+--+--+--+--+--+--+--+--+--+--+--+--+

```

The structure of the label in the case of CWDM is the same as that of DWDM case.

(1) Grid: 3 bits

The value for grid is set to 2 for ITU-T CWDM Grid as defined in [\[G.694.2\]](#).

Grid	Value
Reserved	0
ITU-T DWDM	1
ITU-T CWDM	2
Future use	3 - 7

(2) C.S.(channel spacing): 4 bits

CWDM channel spacing is defined as follows.

C.S(nm)	Value
Reserved	0
20	1
Future use	2 - 15

(3) Identifier: 9 bits

The identifier field is a per-node assigned and scoped value. This field MAY change on a per-hop basis. In all cases but one, a node MAY

select any value, including zero (0), for this field. Once selected, the value MUST NOT change until the LSP is torn down and the value MUST be used in all LSP related messages, e.g., in Resv messages and label RRO subobjects. The sole special case occurs when this label

format is used in a label ERO subobject. In this case, the special value of zero (0) means that the referenced node MAY assign any Identifier field value, including zero (0), when establishing the corresponding LSP.

(4) n: 16 bits

n is a two's-complement integer. The value used to compute the wavelength as shown above.

[4. Security Considerations](#)

This document introduces no new security considerations to [\[RFC3471\]](#) and [\[RFC3473\]](#). For a general discussion on MPLS and GMPLS related security issues, see the MPLS/GMPLS security framework [\[RFC5920\]](#).

[5. IANA Considerations](#)

IANA maintains the "Generalized Multi-Protocol Label Switching (GMPLS) Signaling Parameters" registry. IANA is requested to add three new subregistries to track the codepoints (Grid and C.S.) used in the DWDM and CWDM Wavelength Labels, which are described in the following sections.

[5.1. Grid Subregistry](#)

Initial entries in this subregistry are as follows:

Value	Grid	Reference
0	Reserved	[This.I-D]
1	ITU-T DWDM	[This.I-D]
2	ITU-T CWDM	[This.I-D]
3-7	Not assigned at this time	[This.I-D]

New values are assigned according to Standards Action.

[5.2. DWDM Channel Spacing Subregistry](#)

Initial entries in this subregistry are as follows:

Value	Channel Spacing (GHz)	Reference
0	Reserved	[This.I-D]
1	100	[This.I-D]
2	50	[This.I-D]
3	25	[This.I-D]
4	12.5	[This.I-D]
5-15	Not assigned at this time	[This.I-D]

New values are assigned according to Standards Action.

5.3. CWDM Channel Spacing Subregistry

Initial entries in this subregistry are as follows:

Value	Channel Spacing (nm)	Reference
0	Reserved	[This.I-D]
1	20	[This.I-D]
2-15	Not assigned at this time	[This.I-D]

New values are assigned according to Standards Action.

6. Acknowledgments

The authors would like to thank Adrian Farrel, Lou Berger, Lawrence Mao, Zafar Ali and Daniele Ceccarelli for the discussion and their comments.

7. References

7.1. Normative References

- [RFC2119] Bradner, S., "Key words for use in RFCs to Indicate Requirement Levels", [BCP 14](#), [RFC 2119](#), March 1997.
- [RFC3471] Berger, L., "Generalized Multi-Protocol Label Switching (MPLS) Signaling Functional Description", [RFC 3471](#), January 2003.
- [RFC3473] Berger, L., "Generalized Multi-Protocol Label Switching (MPLS) Signaling - Resource ReserVation Protocol Traffic Engineering (RSVP-TE) Extensions", [RFC 3473](#), January 2003.
- [RFC3945] Mannie, E., Ed., "Generalized Multiprotocol Label Switching (GMPLS) Architecture", [RFC 3945](#), October 2004.

7.2. Informative References

- [G.694.1] ITU-T Recommendation G.694.1, "Spectral grids for WDM applications: DWDM frequency grid", June 2002.
- [G.694.2] ITU-T Recommendation G.694.2, "Spectral grids for WDM applications: CWDM wavelength grid", December 2003.
- [RFC5920] Fang, L., "Security Framework for MPLS and GMPLS Networks", [RFC 5920](#), July 2010.

[draft-ietf-ccamp-gmpls-g-694-lambda-labels-10.txt](#)

December 2010

8. Authors' Address

Tomohiro Otani
KDDI Corporation
2-3-2 Nishishinjuku Shinjuku-ku
Tokyo, 163-8003, Japan
Phone: +81-3-3347-6006
Email: tm-otani@kddi.com

Richard Rabbat
Google, Inc.
1600 Amphitheatre Pkwy
Mountain View, CA 94043
Email: rabbat@alum.mit.edu

Sidney Shiba
Email: sidney.shiba@att.net

Hongxiang Guo
Email: hongxiang.guo@gmail.com

Keiji Miyazaki
Fujitsu Laboratories Ltd
4-1-1 Kotanaka Nakahara-ku,
Kawasaki Kanagawa, 211-8588, Japan
Phone: +81-44-754-2765
Email: miyazaki.keiji@jp.fujitsu.com

Diego Caviglia
Ericsson
16153 Genova Cornigliano, ITALY
Phone: +390106003736
Email: diego.caviglia@ericsson.com

Dan Li
Huawei Technologies
F3-5-B R&D Center, Huawei Base,
Shenzhen 518129 China
Phone: +86 755-289-70230
Email: danli@huawei.com

Takehiro Tsuritani

KDDI R&D Laboratories Inc.
 2-1-15 Ohara Fujimino-shi
 Saitama, 356-8502, Japan
 Phone: +81-49-278-7806
 Email: tsuri@kddilabs.jp

9. Appendix A. DWDM Example

Considering the network displayed in figure 1 it is possible to show an example of LSP set up using the lambda labels.

Node 1 receives the request for establishing an LSP from itself to Node 9. The ITU-T grid to be used is the DWDM one, the channel spacing is 50Ghz and the wavelength to be used is 193,35 THz.

Node 1 signals the LSP via a Path message including a Wavelength Label structured as defined in [section 4.2](#):

```

      0              1              2              3
    0 1 2 3 4 5 6 7 8 9 0 1 2 3 4 5 6 7 8 9 0 1 2 3 4 5 6 7 8 9 0 1
  +--+--+--+--+--+--+--+--+--+--+--+--+--+--+--+--+--+--+--+--+--+--+
  |Grid| C.S | Identifier |                               | n |
  +--+--+--+--+--+--+--+--+--+--+--+--+--+--+--+--+--+--+--+--+--+--+
  
```

Where:

Grid = 1 : ITU-T DWDM grid

C.S. = 2 : 50 GHz channel spacing

n = 5 :

$$\text{Frequency (THz)} = 193.1 \text{ THz} + n * \text{channel spacing (THz)}$$

$$193.35 \text{ (THz)} = 193.1 \text{ (THz)} + n * 0.05 \text{ (THz)}$$

$$n = (193.35 - 193.1) / 0.05 = 5$$

10. Appendix B. CWDM Example

The network displayed in figure 1 can be used also to display an example of signaling using the Wavelength Label in a CWDM

environment.

This time the signaling of an LSP from Node 4 to Node 7 is considered. Such LSP exploits the CWDM ITU-T grid with a 20nm channel spacing and is established using wavelength equal to 1331 nm.

Node 4 signals the LSP via a Path message including a Wavelength Label structured as defined in [section 4.3](#):

```

      0                1                2                3
0 1 2 3 4 5 6 7 8 9 0 1 2 3 4 5 6 7 8 9 0 1 2 3 4 5 6 7 8 9 0 1
+---+---+---+---+---+---+---+---+---+---+---+---+---+---+---+---+
|Grid| C.S | Identifier |                               n |
+---+---+---+---+---+---+---+---+---+---+---+---+---+---+---+---+
```

Where:

Grid = 2 : ITU-T CWDM grid

C.S. = 1 : 20 nm channel spacing

n = -7 :

$$\text{Wavelength (nm)} = 1471 \text{ nm} + n * 20 \text{ nm}$$

$$1331 \text{ (nm)} = 1471 \text{ (nm)} + n * 20 \text{ nm}$$

$$n = (1331-1471)/20 = -7$$

