

ECRIT
Internet-Draft
Intended status: Standards Track
Expires: January 14, 2014

H. Schulzrinne
Columbia University
S. McCann
Research in Motion UK Ltd
G. Bajko
Nokia
H. Tschofenig
Nokia Siemens Networks
D. Kroeselberg
Siemens
July 13, 2013

Extensions to the Emergency Services Architecture for dealing with
Unauthenticated and Unauthorized Devices
draft-ietf-ecrit-unauthenticated-access-07.txt

Abstract

The IETF emergency services architecture assumes that the calling device has acquired rights to use the access network or that no authentication is required for the access network, such as for public wireless access points. Subsequent protocol interactions, such as obtaining location information, learning the address of the Public Safety Answering Point (PSAP) and the emergency call itself are largely decoupled from the underlying network access procedures.

In some cases, however, the device does not have these credentials for network access, does not have a VoIP service provider, or the credentials have become invalid, e.g., because the user has exhausted their prepaid balance or the account has expired.

This document provides a problem statement, introduces terminology and describes an extension for the base IETF emergency services architecture to address these scenarios.

Status of This Memo

This Internet-Draft is submitted in full conformance with the provisions of [BCP 78](#) and [BCP 79](#).

Internet-Drafts are working documents of the Internet Engineering Task Force (IETF). Note that other groups may also distribute working documents as Internet-Drafts. The list of current Internet-Drafts is at <http://datatracker.ietf.org/drafts/current/>.

Internet-Drafts are draft documents valid for a maximum of six months and may be updated, replaced, or obsoleted by other documents at any

Internet-Draft

Unauthenticated Emergency Service

July 2013

time. It is inappropriate to use Internet-Drafts as reference material or to cite them other than as "work in progress."

This Internet-Draft will expire on January 14, 2014.

Copyright Notice

Copyright (c) 2013 IETF Trust and the persons identified as the document authors. All rights reserved.

This document is subject to [BCP 78](#) and the IETF Trust's Legal Provisions Relating to IETF Documents (<http://trustee.ietf.org/license-info>) in effect on the date of publication of this document. Please review these documents carefully, as they describe your rights and restrictions with respect to this document. Code Components extracted from this document must include Simplified BSD License text as described in Section 4.e of the Trust Legal Provisions and are provided without warranty as described in the Simplified BSD License.

Table of Contents

1.	Introduction	3
2.	Terminology	5
3.	Use Case Categories	5
4.	ZBP Considerations	7
5.	NASP Considerations	8
5.1.	End Host Profile	10
5.1.1.	LoST Server Discovery	10
5.1.2.	ESRP Discovery	10
5.1.3.	Location Determination and Location Configuration . .	10
5.1.4.	Emergency Call Identification	10
5.1.5.	SIP Emergency Call Signaling	10
5.1.6.	Media	11
5.1.7.	Testing	11
5.2.	IAP/ISP Profile	11
5.2.1.	ESRP Discovery	11
5.2.2.	Location Determination and Location Configuration . .	11
5.3.	ESRP Profile	11
5.3.1.	Emergency Call Routing	11
5.3.2.	Emergency Call Identification	12
5.3.3.	SIP Emergency Call Signaling	12
6.	Lower Layer Considerations for NAA Case	12

6.1.	Link Layer Emergency Indication	13
6.2.	Securing Network Attachment in NAA Cases	14
7.	Security Considerations	15
8.	Acknowledgments	16
9.	IANA Considerations	16

10.	References	16
10.1.	Normative References	16
10.2.	Informative References	17
	Authors' Addresses	18

[1.](#) Introduction

Summoning police, the fire department or an ambulance in emergencies is one of the fundamental and most-valued functions of the telephone. As telephone functionality moves from circuit-switched telephony to Internet telephony, its users rightfully expect that this core functionality will continue to work at least as well as it has for the older technology. New devices and services are being made available that could be used to make a request for help, which are not traditional telephones, and users are increasingly expecting them to be used to place emergency calls.

Roughly speaking, the IETF emergency services architecture (see [[RFC6881](#)] and [[RFC6443](#)]) divides responsibility for handling emergency calls between the access network (ISP), the application service provider (ASP) that may be a VoIP service provider and the provider of emergency signaling services, the emergency service network (ESN). The access network may provide location information to end systems, but does not have to provide any ASP signaling functionality. The emergency caller can reach the ESN either directly or through the ASP's outbound proxy. Any of the three parties can provide the mapping from location to PSAP URI by offering LoST [[RFC5222](#)] services.

In general, a set of automated configuration mechanisms allows a device to function in a variety of architectures, without the user being aware of the details on who provides location, mapping services or call routing services. However, if emergency calling is to be supported when the calling device lacks access network authorization or does not have an ASP, one or more of the providers may need to provide additional services and functions.

In all cases, the end device has to be able to perform a LoST lookup and otherwise conduct the emergency call in the same manner as when the three exceptional conditions discussed below do not apply.

We distinguish between three conditions:

No Access Authentication (NAA): In the NAA case, the emergency caller does not possess valid credentials for the access network. This includes the case where the access network allows pay-per-use, as is common for wireless hotspots, but there is insufficient time to enter credit card details and other registration

information required for access. It also covers all cases where either no credentials are available at all, or the available credentials do not work for the given IAP/ISP. As a result, the NAA case basically combines the below NASP and ZBP cases, but at the IAP/ISP level. Support for emergency call handling in the NAA case is subject to the local policy of the ISP. Such policy may vary substantially between ISPs and typically depends on external factors that are not under the ISP control.

No ASP (NASP): The caller does not have an ASP at the time of the call. This can occur either in case the caller does not possess any valid subscription for a reachable ASP, or in case none of the ASPs where the caller owns a valid subscription is reachable through the ISP.

Note: The interoperability need is increased with this scenario since the client software used by the emergency caller must be compatible with the protocols and extensions deployed by the ESN.

Zero-balance ASP (ZBP): In the case of zero-balance ASP, the ASP can authenticate the caller, but the caller is not authorized to use ASP services, e.g., because the contract has expired or the prepaid account for the customer has been depleted.

These three cases are not mutually exclusive. A caller in need for help may find himself/herself in, for example, a NAA and NASP

situation, as explained in more details in Figure 1. Depending on local policy and regulations, it may not be possible to place emergency calls in the NAA case. Unless local regulations require user identification, it should always be possible to place calls in the NASP case, with minimal impact on the ISP. Unless the ESN requires that all calls traverse a known set of VSPs, it is technically possible to let a caller place an emergency call in the ZBP case. We discuss each case in more details in [Section 3](#).

Note: At the time of writing there is no regulation in place that demands the functionality described in this memo. SDOs have started their work on this subject in a proactive fashion in the anticipation that national regulation will demand it for a subset of network environments.

There are also indications that the functionality of unauthenticated emergency calls (called SIM-less calls) in today's cellular system in certain countries leads to a fair amount of hoax or test calls. This causes overload situations at PSAPs which is considered harmful to the overall availability and reliability of emergency services.

As an example, Federal Office of Communications (OFCOM, Switzerland) provided statistics about emergency (112) calls in Switzerland from Jan. 1997 to Nov. 2001. Switzerland did not offer SIM-less emergency calls except for almost a month in July 2000 where a significant increase in hoax and test calls was reported. As a consequence, the functionality was disabled again. More details can be found in the panel presentations of the 3rd SDO Emergency Services Workshop [[esw07](#)].

[2](#). Terminology

In this document, the key words "MUST", "MUST NOT", "REQUIRED", "SHALL", "SHALL NOT", "SHOULD", "SHOULD NOT", "RECOMMENDED", "MAY", and "OPTIONAL" are to be interpreted as described in [RFC 2119](#) [[RFC2119](#)].

This document reuses terminology from [[RFC5687](#)] and [[RFC5012](#)], namely Internet Access Provider (IAP), Internet Service Provider (ISP), Application Service Provider (ASP), Voice Service Provider (VSP), Emergency Service Routing Proxy (ESRP), Public Safety Answering Point (PSAP), Location Configuration Server (LCS), (emergency) service dial string, and (emergency) service identifier.

3. Use Case Categories

On a very high-level, the steps to be performed by an end host not being attached to the network and the user starting to make an emergency call are the following:

Link Layer Attachment: Some radio networks have added support for unauthenticated emergency access, some other type of networks advertise these capabilities using layer beacons. The end host learns about these unauthenticated emergency services capabilities either from the link layer type or from advertisement.

The end host uses the link layer specific network attachment procedures defined for unauthenticated network access in order to get access to the network.

Pre-Emergency Service Configuration: When the link layer network attachment procedure is completed the end host learns basic

configuration information using DHCP from the ISP. The end host uses a Location Configuration Protocol (LCP) to retrieve location information. Subsequently, the LoST protocol [[RFC5222](#)] is used to learn the relevant emergency numbers, and to obtain the PSAP URI applicable for that location.

Emergency Call: In case of need for help, a user dials an emergency number and the SIP UA initiates the emergency call procedures by communicating with the PSAP.

Figure 1 compiles the basic logic taking place during network entry for requesting an emergency service and shows the interrelation between the three conditions described in the above section.

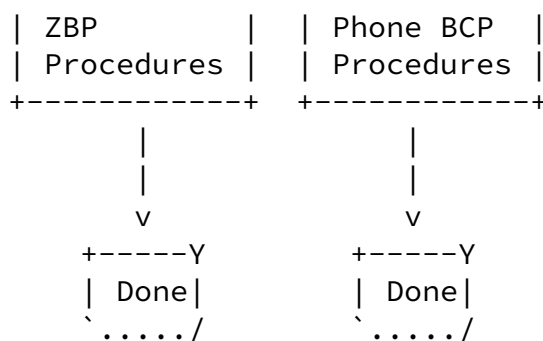

Abbreviations:

LLA: Link Layer Attachment

ES: Emergency Services

Figure 1: Flow Diagram

The "No Access Authentication (NAA)" procedures are described in [Section 6](#). The "Zero-balance ASP (ZBP)" procedures are described in [Section 4](#). The "No ASP (NASP)" procedures are described in [Section 5](#). The Phone BCP procedures are described in [[RFC6881](#)]. The "Link Layer Attachment (LLA)" procedures are not described in this document since they are specific to the link layer technology in use.

4. ZBP Considerations

ZBP includes all cases where a subscriber is known to an ASP, but lacks the necessary authorization to access regular ASP services. Example ZBP cases include empty prepaid accounts, barred accounts, roaming and mobility restrictions, or any other conditions set by ASP policy.

Local regulation might demand that emergency calls cannot proceed without successful service authorization. In regulatory regimes, however, it may be possible to allow emergency calls to continue despite authorization failures. To distinguish an emergency call from a regular call an ASP can identify emergency sessions by inspecting the service URN [[RFC5031](#)] used in call setup. The ZBP case therefore only affects the ASP.

opportunity for abuse. The ASP may choose to verify the destination of the emergency calls and to only permit calls to certain, pre-configured entities (e.g., to local PSAPs). [Section 7](#) discusses this topic in more detail.

An ASP without a regulatory requirement to authorize emergency calls can deny emergency call setup. Where an ASP does not authorize an emergency call, the caller may be able to fall back to NASP procedures.

[5.](#) NASP Considerations

To start the description we consider the sequence of steps that are executed in an emergency call based on Figure 2.

- o As an initial step the devices attaches to the network as shown in step (1). This step is outside the scope of this section.
- o When the link layer network attachment procedure is completed the end host learns basic IP configuration information using DHCP from the ISP, as shown in step (2).
- o When the IP address configuration is completed then the end host starts an interaction with the discovered Location Configuration Server at the ISP, as shown in step (3). The ISP may in certain deployments need to interact with the IAP. This protocol exchange is shown in step (4).
- o Once location information is obtained the end host triggers the LoST protocol to obtain the address of the ESRP/PSAP. This step is shown in (5).
- o In step (6), the SIP UA initiates a SIP INVITE towards the indicated ESRP. The INVITE message contains all the necessary parameters required by [Section 5.1.5](#).
- o The ESRP receives the INVITE and processes it according to the description in [Section 5.3.3](#).
- o The ESRP routes the call to the PSAP, as shown in (8), potentially interacting with a LoST server first to determine the route.
- o The PSAP evaluates the initial INVITE and aims to complete the call setup.
- o Finally, when the call setup is completed media traffic can be exchanged between the PSAP and the SIP UA.

For editorial reasons the end-to-end SIP and media exchange between the PSAP and SIP UA are not shown in Figure 2.

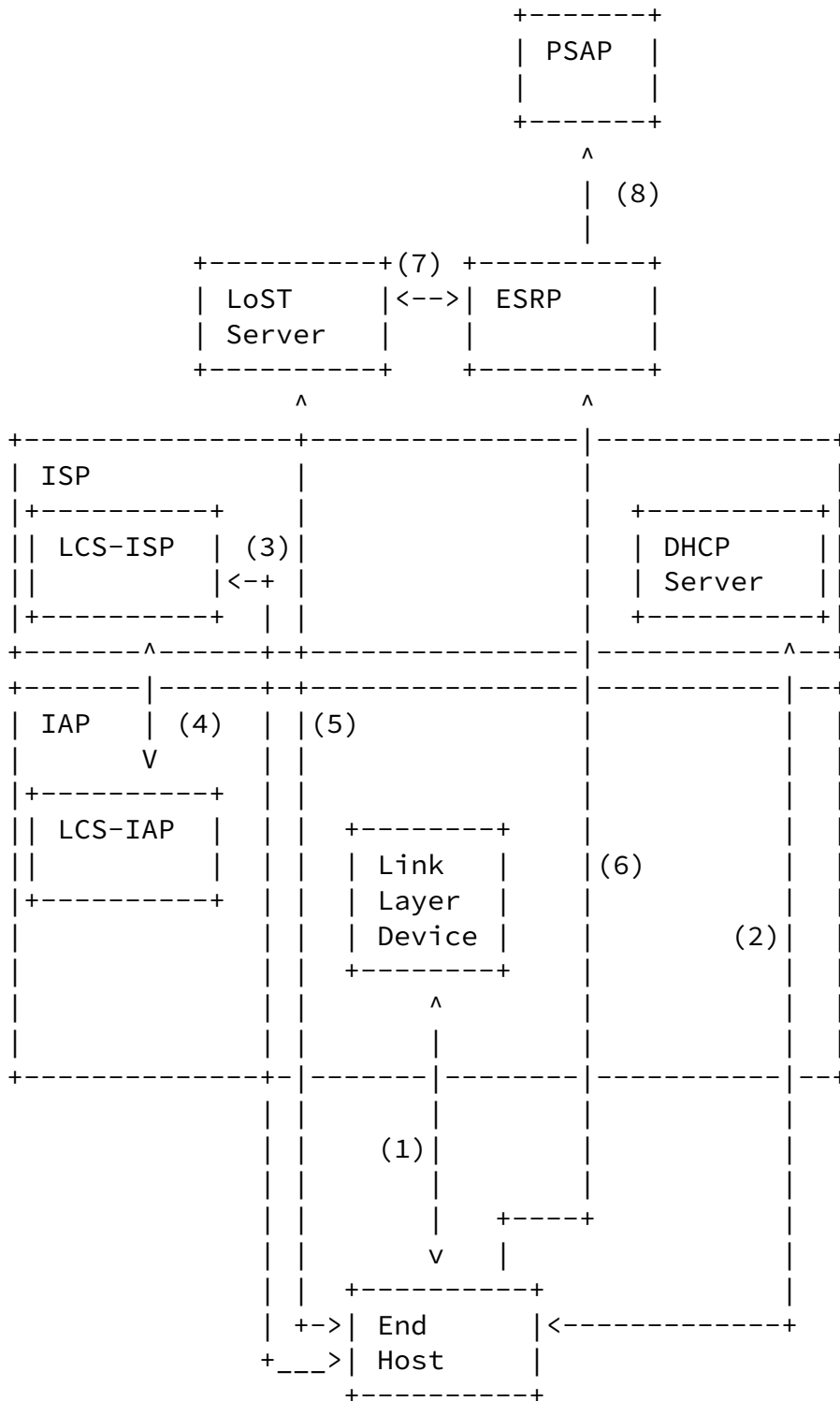

Figure 2: Architectural Overview

Note: Figure 2 does not indicate who operates the ESRP and the LoST server. Various deployment options exist.

[5.1.](#) End Host Profile

[5.1.1.](#) LoST Server Discovery

The end host MUST discover a LoST server [[RFC5222](#)] using DHCP [[RFC5223](#)].

[5.1.2.](#) ESRP Discovery

The end host MUST discover the ESRP using the LoST protocol [[RFC5222](#)].

[5.1.3.](#) Location Determination and Location Configuration

The end host MUST support location acquisition and the LCPs described in [Section 6.5 of \[RFC6881\]](#). The description in [Section 6.5](#) and 6.6 of [[RFC6881](#)] regarding the interaction between the device and the LIS applies to this document.

The SIP UA in the end host MUST attach available location information in a PIDF-LO [[RFC4119](#)] when making an emergency call. When constructing the PIDF-LO the guidelines in PIDF-LO profile [[RFC5491](#)] MUST be followed. For civic location information the format defined in [[RFC5139](#)] MUST be supported.

[5.1.4.](#) Emergency Call Identification

To determine which calls are emergency calls, some entity needs to map a user entered dialstring into this URN scheme. A user may "dial" 1-1-2, 9-1-1, etc., but the call would be sent to urn:service:sos. This mapping SHOULD be performed at the endpoint device.

End hosts MUST use the Service URN mechanism [[RFC5031](#)] to mark calls as emergency calls for their home emergency dial string.

[5.1.5.](#) SIP Emergency Call Signaling

SIP signaling capabilities [[RFC3261](#)] are mandated for end hosts.

The initial SIP signaling method is an INVITE. The SIP INVITE request MUST be constructed according to the requirements in [Section 9.2 \[RFC6881\]](#).

Regarding callback behavior SIP UAs SHOULD place a globally routable URI in a Contact: header.

Schulzrinne, et al.

Expires January 14, 2014

[Page 10]

Internet-Draft

Unauthenticated Emergency Service

July 2013

[5.1.6.](#) Media

End points MUST comply with the media requirements for end points placing an emergency call found in [Section 14 of \[RFC6881\]](#).

[5.1.7.](#) Testing

The description in [Section 15 of \[RFC6881\]](#) is fully applicable to this document.

[5.2.](#) IAP/ISP Profile

[5.2.1.](#) ESRP Discovery

An ISP MUST provision a DHCP server with information about LoST servers [[RFC5223](#)]. An ISP operator may choose to deploy a LoST server or to outsource it to other parties.

[5.2.2.](#) Location Determination and Location Configuration

The ISP is responsible for location determination and exposes this information to the end points via location configuration protocols. The considerations described in [[RFC6444](#)] are applicable to this document.

The ISP MUST support one of the LCPs described in [Section 6.5 of \[RFC6881\]](#). The description in [Section 6.5](#) and 6.6 of [[RFC6881](#)] regarding the interaction between the end device and the LIS applies to this document.

The interaction between the LIS at the ISP and the IAP is often proprietary but the description in

[\[I-D.winterbottom-geopriv-lis2lis-req\]](#) may be relevant to the reader.

[5.3.](#) ESRP Profile

[5.3.1.](#) Emergency Call Routing

The ESRP continues to route the emergency call to the PSAP responsible for the physical location of the end host. This may require further interactions with LoST servers but depends on the specific deployment.

Schulzrinne, et al. Expires January 14, 2014 [Page 11]

Internet-Draft Unauthenticated Emergency Service July 2013

[5.3.2.](#) Emergency Call Identification

The ESRP MUST understand the Service URN mechanism [\[RFC5031\]](#) (i.e., the 'urn:service:sos' tree).

[5.3.3.](#) SIP Emergency Call Signaling

SIP signaling capabilities [\[RFC3261\]](#) are mandated for the ESRP. The ESRP MUST process the messages sent by the client, according to [Section 5.1.5](#).

[6.](#) Lower Layer Considerations for NAA Case

Some radio networks have added support for unauthenticated emergency access, some other type of networks advertise these capabilities using layer beacons. The end host learns about these unauthenticated emergency services capabilities either from the link layer type or from advertisement.

This section discusses different methods to indicate an emergency service request as part of network attachment. It provides some general considerations and recommendations that are not specific to the access technology.

To perform network attachment and get access to the resources

provided by an IAP/ISP, the end host uses access technology specific network attachment procedures, including for example network detection and selection, authentication, and authorization. For initial network attachment of an emergency service requester, the method of how the emergency indication is given to the IAP/ISP is specific to the access technology. However, a number of general approaches can be identified:

Link layer emergency indication: The end host provides an indication, e.g., an emergency parameter or flag, as part of the link layer signaling for initial network attachment. Examples include an emergency bit signalled in the IEEE 802.16-2009 wireless link. In IEEE 802.11 WLAN, an emergency support indicator allows the STA to download before association an NAI which it can use to request server side authentication only for an 802.1x network.

Higher-layer emergency indication: Typically emergency indication in access authentication. The emergency caller's end host provides an indication as part of the access authentication exchanges. EAP based authentication is of particular relevance here. Examples are the EAP NAI decoration used in WiMAX networks and modification of the authentication exchange in IEEE 802.11. [[nwgstg3](#)].

[6.1](#). Link Layer Emergency Indication

In general, link layer emergency indications provide good integration into the actual network access procedure regarding the enabling of means to recognize and prioritize an emergency service request from an end host at a very early stage of the network attachment procedure. However, support in end hosts for such methods cannot be considered to be commonly available.

No general recommendations are given in the scope of this memo due to

the following reasons:

- o Dependency on the specific access technology.
- o Dependency on the specific access network architecture. Access authorization and policy decisions typically happen at a different layers of the protocol stack and in different entities than those terminating the link-layer signaling. As a result, link layer indications need to be distributed and translated between the different involved protocol layers and entities. Appropriate methods are specific to the actual architecture of the IAP/ISP network.
- o An advantage of combining emergency indications with the actual network attachment procedure performing authentication and authorization is the fact that the emergency indication can directly be taken into account in the authentication and authorization server that owns the policy for granting access to the network resources. As a result, there is no direct dependency on the access network architecture that otherwise would need to take care of merging link-layer indications into the AA and policy decision process.
- o EAP signaling happens at a relatively early stage of network attachment, so it is likely to match most requirements for prioritization of emergency signaling. However, it does not cover early stages of link layer activity in the network attachment process. Possible conflicts may arise e.g. in case of MAC-based filtering in entities terminating the link-layer signaling in the network (like a base station). In normal operation, EAP related

information will only be recognized in the NAS. Any entity residing between end host and NAS should not be expected to understand/parse EAP messages.

- o An emergency indication can be given by forming a specific NAI that is used as the identity in EAP based authentication for network entry.

[6.2.](#) Securing Network Attachment in NAA Cases

For network attachment in NAA cases, it may make sense to secure the

link-layer connection between the device and the IAP/ISP. This especially holds for wireless access with examples being IEEE 802.11 or IEEE 802.16 based access. The latter even mandates secured communication across the wireless link for all IAP/ISP networks based on [[nwgstg3](#)].

Therefore, for network attachment that is by default based on EAP authentication it is desirable also for NAA network attachment to use a key-generating EAP method (that provides an MSK key to the authenticator to bootstrap further key derivation for protecting the wireless link).

The following approaches to match the above can be identified:

1) Server-only Authentication:

The device of the emergency service requester performs an EAP method with the IAP/ISP EAP server that performs server side authentication only. An example for this is EAP-TLS. This provides a certain level of assurance about the IAP/ISP to the device user. It requires the device to be provisioned with appropriate trusted root certificates to be able to verify the server certificate of the EAP server (unless this step is explicitly skipped in the device in case of an emergency service request). This method is used to provide access of devices without existing credentials to an 802.1x network. The details are incorporated into the not yet published 802.11-2011 specification.

2) Null Authentication:

In one case (e.g., WiMAX) an EAP method is performed. However, no credentials specific to either the server or the device or subscription are used as part of the authentication exchange. An example for this would be an EAP-TLS exchange with using the TLS_DH_anon (anonymous) ciphersuite. Alternatively, a publicly

available static key for emergency access could be used. In the latter case, the device would need to be provisioned with the appropriate emergency key for the IAP/ISP in advance. In another case (e.g., IEEE 802.11), no EAP method is used, so that empty

frames are transported during the over the air IEEE 802.1X exchange. In this case the authentication state machine completes with no cryptographic keys being exchanged.

3) Device Authentication:

This case extends the server-only authentication case. If the device is configured with a device certificate and the IAP/ISP EAP server can rely on a trusted root allowing the EAP server to verify the device certificate, at least the device identity (e.g., the MAC address) can be authenticated by the IAP/ISP in NAA cases. An example for this are WiMAX devices that are shipped with device certificates issued under the global WiMAX device public-key infrastructure. To perform unauthenticated emergency calls, if allowed by the IAP/ISP, such devices perform EAP-TLS based network attachment with client authentication based on the device certificate.

7. Security Considerations

The security threats discussed in [[RFC5069](#)] are applicable to this document.

There are a couple of new vulnerabilities raised with unauthenticated emergency services in NASP/NAA cases since the PSAP operator will typically not possess any identity information about the emergency call via the signaling path itself. In countries where this functionality is used for GSM networks today this has led to a significant amount of misuse.

In the context of NAA, the IAP and the ISP will probably want to make sure that the claimed emergency caller indeed performs an emergency call rather than using the network for other purposes, and thereby acting fraudulent by skipping any authentication, authorization and accounting procedures. By restricting access of the unauthenticated emergency caller to the LoST server and the PSAP URI, traffic can be restricted only to emergency calls. This can be accomplished with traffic separation. The details, however, e.g. for using filtering, depend on the deployed ISP architecture and are beyond the scope of this document.

We only illustrate a possible model. If the ISP runs its own LoST server, it would maintain an access control list including all IP

addresses contained in responses returned by the LoST server, as well as the LoST server itself. (It may need to translate the domain names returned to IP addresses and hope that the resolution captures all possible DNS responses.) Since the media destination addresses are not predictable, the ISP also has to provide a SIP outbound proxy so that it can determine the media addresses and add those to the filter list.

For the ZBP case the additional aspect of fraud has to be considered. Unless the emergency call traverses a PSTN gateway or the ASP charges for IP-to-IP calls, there is little potential for fraud. If the ASP also operates the LoST server, the outbound proxy MAY restrict outbound calls to the SIP URIs returned by the LoST server. It is NOT RECOMMENDED to rely on a fixed list of SIP URIs, as that list may change.

Finally, a number of security vulnerabilities discussed in [[RFC6280](#)] around faked location information are less problematic in the context of unauthenticated emergency since location information does not need to be provided by the end host itself or it can be verified to fall within a specific geographical area.

[8.](#) Acknowledgments

Parts of this document are derived from [[RFC6881](#)]. Participants of the 2nd and 3rd SDO Emergency Services Workshop provided helpful input.

We would like to thank Richard Barnes, Brian Rosen, James Polk, Marc Linsner, and Martin Thomson for their feedback at the IETF#80 ECRIT meeting.

Furthermore, we would like to thank Martin Thomson and Bernard Aboba for their detailed document review in preparation of the 81st IETF meeting.

[9.](#) IANA Considerations

This document does not require actions by IANA.

[10.](#) References

[10.1.](#) Normative References

- [RFC5031] Schulzrinne, H., "A Uniform Resource Name (URN) for Emergency and Other Well-Known Services", [RFC 5031](#), January 2008.

Internet-Draft

Unauthenticated Emergency Service

July 2013

-
- [RFC4119] Peterson, J., "A Presence-based GEOPRIV Location Object Format", [RFC 4119](#), December 2005.
- [RFC5491] Winterbottom, J., Thomson, M., and H. Tschofenig, "GEOPRIV Presence Information Data Format Location Object (PIDF-L0) Usage Clarification, Considerations, and Recommendations", [RFC 5491](#), March 2009.
- [RFC5139] Thomson, M. and J. Winterbottom, "Revised Civic Location Format for Presence Information Data Format Location Object (PIDF-L0)", [RFC 5139](#), February 2008.
- [RFC3261] Rosenberg, J., Schulzrinne, H., Camarillo, G., Johnston, A., Peterson, J., Sparks, R., Handley, M., and E. Schooler, "SIP: Session Initiation Protocol", [RFC 3261](#), June 2002.
- [RFC2119] Bradner, S., "Key words for use in RFCs to Indicate Requirement Levels", [BCP 14](#), [RFC 2119](#), March 1997.
- [RFC6881] Rosen, B. and J. Polk, "Best Current Practice for Communications Services in Support of Emergency Calling", [BCP 181](#), [RFC 6881](#), March 2013.
- [RFC5222] Hardie, T., Newton, A., Schulzrinne, H., and H. Tschofenig, "LoST: A Location-to-Service Translation Protocol", [RFC 5222](#), August 2008.
- [RFC5223] Schulzrinne, H., Polk, J., and H. Tschofenig, "Discovering Location-to-Service Translation (LoST) Servers Using the Dynamic Host Configuration Protocol (DHCP)", [RFC 5223](#), August 2008.

[10.2.](#) Informative References

- [RFC5687] Tschofenig, H. and H. Schulzrinne, "GEOPRIV Layer 7 Location Configuration Protocol: Problem Statement and Requirements", [RFC 5687](#), March 2010.
- [RFC6443] Rosen, B., Schulzrinne, H., Polk, J., and A. Newton,

"Framework for Emergency Calling Using Internet Multimedia", [RFC 6443](#), December 2011.

[RFC5012] Schulzrinne, H. and R. Marshall, "Requirements for Emergency Context Resolution with Internet Technologies", [RFC 5012](#), January 2008.

Schulzrinne, et al. Expires January 14, 2014 [Page 17]

Internet-Draft Unauthenticated Emergency Service July 2013

[RFC6444] Schulzrinne, H., Liess, L., Tschofenig, H., Stark, B., and A. Kuett, "Location Hiding: Problem Statement and Requirements", [RFC 6444](#), January 2012.

[I-D.winterbottom-geopriv-lis2lis-req]
Winterbottom, J. and S. Norreys, "LIS to LIS Protocol Requirements", [draft-winterbottom-geopriv-lis2lis-req-01](#) (work in progress), November 2007.

[RFC5069] Taylor, T., Tschofenig, H., Schulzrinne, H., and M. Shanmugam, "Security Threats and Requirements for Emergency Call Marking and Mapping", [RFC 5069](#), January 2008.

[RFC6280] Barnes, R., Lepinski, M., Cooper, A., Morris, J., Tschofenig, H., and H. Schulzrinne, "An Architecture for Location and Location Privacy in Internet Applications", [BCP 160](#), [RFC 6280](#), July 2011.

[esw07] , "3rd SDO Emergency Services Workshop, <http://www.emergency-services-coordination.info/2007Nov/>", October 30th - November 1st 2007.

[nwgstg3] , "WiMAX Forum WMF-T33-001-R015V01, WiMAX Network Architecture Stage-3 http://www.wimaxforum.org/sites/wimaxforum.org/files/technical_document/2009/09/DRAFT-T33-001-R015v01-0_Network-Stage3-Base.pdf", September 2009.

Authors' Addresses

Henning Schulzrinne
Columbia University

Department of Computer Science
450 Computer Science Building
New York, NY 10027
US

Phone: +1 212 939 7004
Email: hgs+ecrit@cs.columbia.edu
URI: <http://www.cs.columbia.edu>

Schulzrinne, et al. Expires January 14, 2014 [Page 18]

Internet-Draft Unauthenticated Emergency Service July 2013

Stephen McCann
Research in Motion UK Ltd
200 Bath Road
Slough, Berks SL1 3XE
UK

Phone: +44 1753 667099
Email: smccann@rim.com
URI: <http://www.rim.com>

Gabor Bajko
Nokia

Email: Gabor.Bajko@nokia.com

Hannes Tschofenig
Nokia Siemens Networks
Linnoitustie 6
Espoo 02600
Finland

Phone: +358 (50) 4871445
Email: Hannes.Tschofenig@gmx.net
URI: <http://www.tschofenig.priv.at>

Dirk Kroeselberg
Siemens
Germany

Email: dirk.kroeselberg@siemens.com