

Network Working Group
Internet-Draft
Intended status: Best Current Practice
Expires: March 12, 2021

M. McBride
Futurewei
D. Madory
Oracle
J. Tantsura
Apstra
R. Raszuk
Bloomberg LP
H. Li
HPE

September 8, 2020

AS Path Prepending
draft-ietf-grow-as-path-prepend-00

Abstract

AS Path Prepending provides a tool to manipulate the BGP AS_Path attribute through prepending multiple entries of an AS. AS Path Prepending is used to deprioritize a route or alternate path. By prepending the local ASN multiple times, ASs can make advertised AS paths appear artificially longer. Excessive AS Path Prepending has caused routing issues in the internet. This document provides guidance, to the internet community, with how best to utilize AS Path Prepending in order to avoid negatively affecting the internet.

Status of This Memo

This Internet-Draft is submitted in full conformance with the provisions of [BCP 78](#) and [BCP 79](#).

Internet-Drafts are working documents of the Internet Engineering Task Force (IETF). Note that other groups may also distribute working documents as Internet-Drafts. The list of current Internet-Drafts is at <https://datatracker.ietf.org/drafts/current/>.

Internet-Drafts are draft documents valid for a maximum of six months and may be updated, replaced, or obsoleted by other documents at any time. It is inappropriate to use Internet-Drafts as reference material or to cite them other than as "work in progress."

This Internet-Draft will expire on March 12, 2021.

Internet-Draft

AS Path Prepending

September 2020

Copyright Notice

Copyright (c) 2020 IETF Trust and the persons identified as the document authors. All rights reserved.

This document is subject to [BCP 78](#) and the IETF Trust's Legal Provisions Relating to IETF Documents (<https://trustee.ietf.org/license-info>) in effect on the date of publication of this document. Please review these documents carefully, as they describe your rights and restrictions with respect to this document. Code Components extracted from this document must include Simplified BSD License text as described in Section 4.e of the Trust Legal Provisions and are provided without warranty as described in the Simplified BSD License.

Table of Contents

1.	Introduction	2
1.1.	Requirements Language	3
2.	Use Cases	3
3.	Problems	4
3.1.	Excessive Prepending	4
3.2.	Prepending during a routing leak	5
3.3.	Prepending to All	6
3.4.	Memory	6
3.5.	Errant announcement	7
4.	Alternatives to AS Path Prepend	7
5.	Best Practices	7
6.	IANA Considerations	8
7.	Security Considerations	8
8.	Acknowledgement	9
9.	References	9
9.1.	Normative References	9
9.2.	URIs	9
	Authors' Addresses	9

[1.](#) Introduction

The Border Gateway Protocol (BGP) [[RFC4271](#)] specifies the AS_PATH attribute which enumerates ASs a route update has traversed. If the UPDATE message is propagated over an external link, then the local AS number is prepended to the AS_PATH attribute, and the NEXT_HOP attribute is updated with an IP address of the router that should be

used as a next hop to the network. If the UPDATE message is propagated over an internal link, then the AS_PATH attribute and the NEXT_HOP attribute are passed unmodified.

A common practice among operators is to prepend multiple entries of an AS (known as AS Path Prepending) in order to deprioritize a route or a path. This has worked well in practice but the practice is increasing, with both IPv4 and IPv6, and there are inherent risks to the global internet especially with excessive AS Path Prepending. Prepending is frequently employed in an excessive manner such that it renders routes vulnerable to disruption or misdirection. AS Path Prepending is discussed in Use of BGP Large Communities [[RFC8195](#)] and this document provides additional, and specific, guidance to operators on how to be a good internet citizen with the proper use of AS Path Prepending.

[1.1](#). Requirements Language

The key words "MUST", "MUST NOT", "REQUIRED", "SHALL", "SHALL NOT", "SHOULD", "SHOULD NOT", "RECOMMENDED", "MAY", and "OPTIONAL" in this document are to be interpreted as described in [RFC 2119](#) [[RFC2119](#)].

[2](#). Use Cases

There are various reasons that AS Path Prepending is in use today including:

- o Preferring one ISP over another ISP on the same ASBR or across different ASBRs
- o Preferring one ASBR over another ASBR in the same site
- o Utilize one path exclusively and another path solely as a backup
- o Signal to indicate that one path may have a different amount of capacity than another where the lower capacity link still takes traffic

The following illustration, from Geoff Hustons Path Prepending in BGP [[1](#)], shows how AS Prepending is typically used:

Internet-Draft

AS Path Prepending

September 2020

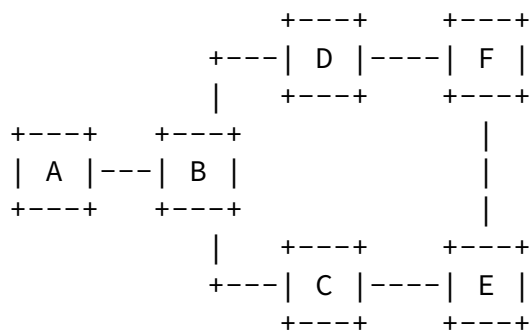

B will normally prefer the path via C to send traffic to E, as this represents the shorter AS path for B. If E were to prepend a further two instances of its own AS number when advertising its routes to C, then B will now see a different situation, where the AS Path via D represents the shorter path. Through the use of selective prepending E is able to alter the routing decision of B, even though B is not an adjacent neighbour of E. The result is that traffic from A and B will be passed via D and F to reach E, rather than via C. In this way prepending implements action at a distance where the routing decisions made by non-adjacent ASs can be influenced by selective AS Path prepending.

In August 2020 a large ISP had a network outage that affected their customers and other ISPs. One major problem was that the ISP wasn't withdrawing BGP routes, the stale routes were continuing to be announced as legitimate by the down ISP. This caused blackholing of traffic even when customers had backup ISPs. What could customers do

in this situation? They could change local preference to help send traffic to the backup ISP. They could send more specifics to the backup ISP. They could also use AS Path Prepend by prepending the same amount to both primary and backup ISPs before failure. Customers could then, during a failure, remove one prepend to the backup ISP to make it more preferred over the down ISP. This is one, of several, scenarios where using AS Path Prepend can be beneficial.

[3.](#) Problems

Since it is so commonly used, what is the problem with the excessive use of AS Path Prepending? Here are a few examples:

[3.1.](#) Excessive Prepending

The risk of excessive use of AS Path Prepending can be illustrated with real-world examples that have been anonymized using documention prefixes [[RFC5737](#)] and ASs [[RFC5398](#)]. Consider the prefix 198.51.100.0/24 which is normally announced with an inordinate amount

of prepending. A recent analysis revealed that 198.51.100.0/24 is announced to the world along the following AS path:

```
64496 64511 64511 64511 64511 64511 64511 64511 64511 64511 64511
64511 64511 64511 64511 64511 64511 64511 64511 64511 64511 64511
64511 64511
```

In this example, the origin AS64511 appears 23 consecutive times before being passed on to a single upstream (AS64496), which passes it on to the global internet, prepended-to-all. An attacker, wanting to intercept or manipulate traffic to this prefix, could enlist a datacenter to allow announcements of the same prefix with a fabricated AS path such as 999999 64496 64511. Here the fictional AS999999 represents the shady datacenter. This malicious route would be preferred due to the shortened AS path length and might go unnoticed by the true origin, even if route-monitoring had been implemented. Standard BGP route monitoring checks a route's origin and upstream and both would be intact in this scenario. The length of the prepending gives the attacker room to craft an AS path that would appear plausible to the casual observer, comply with origin validation mechanisms, and not be detected by off-the-shelf route monitoring.

[3.2.](#) Prepending during a routing leak

In April 2010, a service provider experienced a routing leak. While analyzing the leak something peculiar was noticed. When we ranked the approximately 50,000 prefixes involved in the leak based on how many ASs accepted the leaked routes, most of the impact was constrained to Country A routes. However, two of the top five most-propagated leaked routes (listed in the table below) were Country B routes.

During the routing leak, nearly all of the ASs of the internet preferred the Country A leaked routes for 192.0.2.0/21 and 198.51.100.0/22 because, at the time, these two Country B prefixes were being announced to the entire internet along the following excessively prepended AS path: 64496 64500 64511 64511 64511 64511 64511 64511. Virtually any illegitimate route would be preferred over the legitimate route. In this case, the victim is all but ensuring their victimhood.

There was only a single upstream seen in the prepending example from above, so the prepending was achieving nothing except incurring risk. You would think such mistakes would be relatively rare, especially now, 10 years later. As it turns out, there is quite a lot of prepending-to-all going on right now and during leaks, it doesn't go well for those who make this mistake. While one can debate the

merits of prepending to a subset of multiple transit providers, it is difficult to see the utility in prepending to every provider. In this configuration, the prepending is no longer shaping route propagation. It is simply incentivizing ASs to choose another origin if one were to suddenly appear whether by mistake or otherwise.

[3.3.](#) Prepending to All

Based on analysis done in 2019, Excessive AS Path Prepending [2], out of approximately 750,000 routes in the IPv4 global routing table, nearly 60,000 BGP routes are prepended to 95% or more of hundreds of BGP sources. About 8% of the global routing table, or 1 out of every 12 BGP routes, is configured with prepends to virtually the entire internet. The 60,000 routes include entities of every stripe: governments, financial institutions, even important parts of internet

infrastructure.

Much of the worst propagation of leaked routes during big leak events have been due to routes being prepended-to-all. AS64505 leak of April 2014 (>320,000 prefixes) was prepended-to-all. And the AS64506 leak of June 2015 (>260,000 prefixes) was also prepended-to-all. Prepend-to-all prefixes are those seen as prepended by all (or nearly all) of the ASs of the internet. In this configuration, prepending is no longer shaping route propagation but is simply incentivizing ASs to choose another origin if one were to suddenly appear whether by mistake or otherwise. The percentage of the IPv4 table that is prepended-to-all is growing at 0.5% per year. The IPv6 table is growing slower at 0.2% per year. The reasons for using prepend-to-all appears to be due to 1) the AS forgetting to remove the prepending for one of its transit providers when it is no longer needed and 2) the AS attempting to de-prioritize traffic from transit providers over settlement-free peers and 3) there are simply a lot of errors in BGP routing. Consider the prepended AS path below:

```
64496 64501 64501 64510 64510 64501 64510 64501 64501 64510 64510
64501 64501 64510
```

The prepending here involves a mix of two distinct ASNs (64501 and 64510) with the last two digits transposed.

[3.4.](#) Memory

BGP attribute sets are shared among stored routes, ie, if two stored routes have the same attribute sets, the attribute set is stored only once. AS Paths are shared among attribute sets so that if two stored attribute sets have the same AS Path, then the AS Path is stored only once. Storing them in the control plane is not a big problem. However, AS Paths can be sent in Netflow which is generated in the

forwarding plane. AS Paths are not stored in expensive fast memory on the forwarding plane, but still, using memory on the forwarding plane has greater impact than on the control plane. An AS Path consists of AS_SEQUENCE (and other elements). An AS_SEQUENCE can contain a maximum of 255 ASNs. If the AS Path is longer, then multiple AS_SEQUENCE's are required. The code to parse them and create them is not often exercised and is a potential for bugs in fresh code. The older implementations have these bugs well and truly

shaken out of them. Some BGP implementations have had memory corruption/fragmentation problems with long AS Paths.

[3.5.](#) Errant announcement

There was an Internet-wide outage caused by a single errant routing announcement. In this incident, AS64496 announced its one prefix with an extremely long AS path. Someone entered their ASN instead of the prepend count $64496 \bmod 256 = 252$ prepends and when a path lengths exceeded 255, routers crashed

[4.](#) Alternatives to AS Path Prepend

There are various options to provide path preference without needing to use AS Path Prepend:

- o Use predefined communities that are mapped to a particular behavior when propagated.
- o Announce more specific routes on the preferred path.
- o The BGP Origin Code is an attribute that is used for path selection. The three origin codes are IGP, EGP and Incomplete. We could advertise paths with IGP or EGP origin over the preferred path while the other ASBRs (which would otherwise prepend N times) advertises with an INCOMPLETE origin code.

[5.](#) Best Practices

Many of the best practices, or lack thereof, can be illustrated from the preceding examples. Here's a summary of the best current practices of using AS Path Prepending:

- o Network operators should ensure prepending is absolutely necessary. Many of your networks have excessive prepending
- o There is no need to prepend more than 5 ASs. The following diagram shows that, according to Excessive AS Path Prepending [\[3\]](#), 90% of AS path lengths are 5 ASNs or fewer in length.

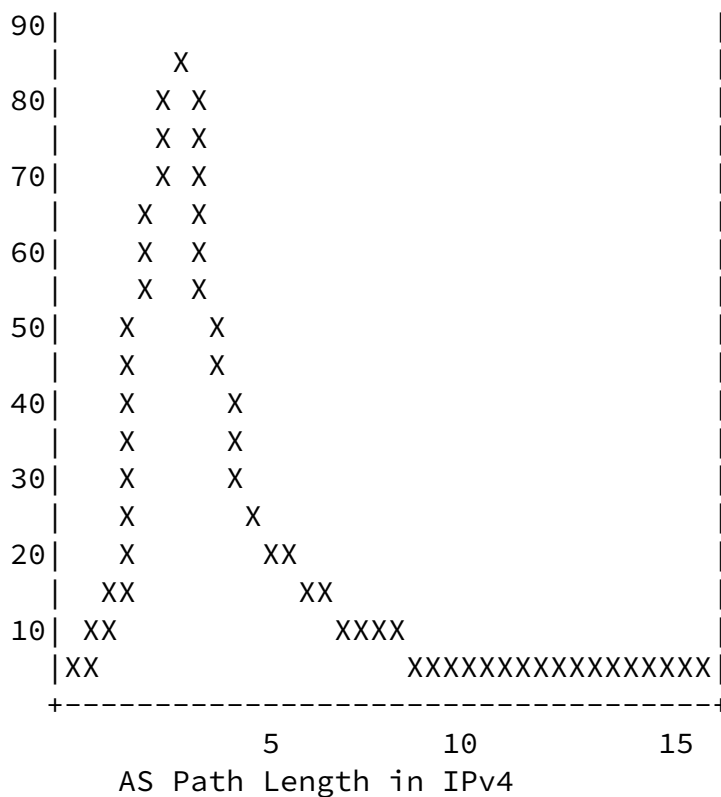

X Axis = unique AS Paths in millions

- o Don't prepend ASNs that you don't own.
- o Prepending-to-all is a self-inflicted and needless risk that serves little purpose. Those excessively prepending their routes should consider this risk and adjust their routing configuration.
- o It is not typical to see more than 20 ASs in a AS_PATH in the Internet today even with the use of AS_Path prepend. The Internet is typically around 5 ASs deep with the largest AS_PATH being 16-20 ASNs. Some have added 100 or more AS Path Prepends and operators should therefore consider limiting the maximum AS-path length being accepted

6. IANA Considerations

7. Security Considerations

There are no security issues introduced by this draft.

8. Acknowledgement

The authors would like to thank Greg Skinner, Randy Bush, Dave Farmer, Nick Hilliard, Martijn Schmidt, Jakob Heitz, Michael Still and Geoff Huston for contributing to this document.

9. References

9.1. Normative References

- [RFC2119] Bradner, S., "Key words for use in RFCs to Indicate Requirement Levels", [BCP 14](#), [RFC 2119](#), DOI 10.17487/RFC2119, March 1997, <<https://www.rfc-editor.org/info/rfc2119>>.
- [RFC4271] Rekhter, Y., Ed., Li, T., Ed., and S. Hares, Ed., "A Border Gateway Protocol 4 (BGP-4)", [RFC 4271](#), DOI 10.17487/RFC4271, January 2006, <<https://www.rfc-editor.org/info/rfc4271>>.
- [RFC5398] Huston, G., "Autonomous System (AS) Number Reservation for Documentation Use", [RFC 5398](#), DOI 10.17487/RFC5398, December 2008, <<https://www.rfc-editor.org/info/rfc5398>>.
- [RFC5737] Arkko, J., Cotton, M., and L. Vegoda, "IPv4 Address Blocks Reserved for Documentation", [RFC 5737](#), DOI 10.17487/RFC5737, January 2010, <<https://www.rfc-editor.org/info/rfc5737>>.
- [RFC8195] Snijders, J., Heasley, J., and M. Schmidt, "Use of BGP Large Communities", [RFC 8195](#), DOI 10.17487/RFC8195, June 2017, <<https://www.rfc-editor.org/info/rfc8195>>.

9.2. URIs

- [1] <https://labs.apnic.net/?p=1264>
- [2] <https://blogs.oracle.com/internetintelligence/excessive-as-path-prepending-is-a-self-inflicted-vulnerability>
- [3] <https://blogs.oracle.com/internetintelligence/excessive-as-path-prepending-is-a-self-inflicted-vulnerability>

Authors' Addresses

Internet-Draft

AS Path Prepending

September 2020

Mike McBride
Futurewei

Email: michael.mcbride@futurewei.com

Doug Madory
Oracle

Email: douglas.madory@oracle.com

Jeff Tantsura
Apstra

Email: jefftant.ietf@gmail.com

Robert Raszuk
Bloomberg LP

Email: robert@raszuk.net

Hongwei Li
HPE

Email: flycoolman@gmail.com

McBride, et al.

Expires March 12, 2021

[Page 10]