

GROW Working Group
Internet-Draft
Intended status: Informational

B. Decraene
France Telecom
P. Francois
UCL
C. Pelsser
IIJ
Z. Ahmad
Orange Business Services
A. J. Elizondo Armengol
Telefonica I+D
T. Takeda
NTT
June 11, 2010

Requirements for the graceful shutdown of BGP sessions
draft-ietf-grow-bgp-graceful-shutdown-requirements-03.txt

Status of this Memo

This Internet-Draft is submitted to IETF in full conformance with the provisions of [BCP 78](#) and [BCP 79](#). This document may contain material from IETF Documents or IETF Contributions published or made publicly available before November 10, 2008. The person(s) controlling the copyright in some of this material may not have granted the IETF Trust the right to allow modifications of such material outside the IETF Standards Process. Without obtaining an adequate license from the person(s) controlling the copyright in such materials, this document may not be modified outside the IETF Standards Process, and derivative works of it may not be created outside the IETF Standards Process, except to format it for publication as an RFC or to translate it into languages other than English.

Internet-Drafts are working documents of the Internet Engineering Task Force (IETF), its areas, and its working groups. Note that other groups may also distribute working documents as Internet-Drafts.

Internet-Drafts are draft documents valid for a maximum of six months and may be updated, replaced, or obsoleted by other documents at any time. It is inappropriate to use Internet-Drafts as reference material or to cite them other than as "work in progress."

The list of current Internet-Drafts can be accessed at <http://www.ietf.org/ietf/lid-abstracts.txt>.

The list of Internet-Draft Shadow Directories can be accessed at <http://www.ietf.org/shadow.html>.

This Internet-Draft will expire on December 08, 2010.

Requirements for the graceful shutdown of BGP sessions

Copyright Notice

Copyright (c) 2010 IETF Trust and the persons identified as the document authors. All rights reserved.

This document is subject to [BCP 78](#) and the IETF Trust's Legal Provisions Relating to IETF Documents (<http://trustee.ietf.org/license-info>) in effect on the date of publication of this document. Please review these documents carefully, as they describe your rights and restrictions with respect to this document. Code Components extracted from this document must include Simplified BSD License text as described in Section 4.e of the Trust Legal Provisions and are provided without warranty as described in the Simplified BSD License.

Abstract

The BGP protocol is heavily used in Service Provider networks both for Internet and BGP/MPLS VPN services. For resiliency purposes, redundant routers and BGP sessions can be deployed to reduce the consequences of an AS Border Router or BGP session breakdown on customers' or peers' traffic. However simply taking down or even bringing up a BGP session for maintenance purposes may still induce connectivity losses during the BGP convergence. This is no more satisfactory for new applications (e.g. voice over IP, on line gaming, VPN). Therefore, a solution is required for the graceful shutdown of a (set of) BGP session(s) in order to limit the amount of traffic loss during a planned shutdown. This document expresses requirements for such a solution.

Table of Contents

1.	Conventions used in this document.....	3
2.	Introduction.....	3
3.	Problem statement.....	4
3.1.	Example of undesirable BGP routing behavior.....	4
3.2.	Causes of packet loss.....	5
4.	Terminology.....	6
5.	Goals and requirements.....	6
6.	Reference Topologies.....	8
6.1.	E-BGP topologies.....	8

6.2.	I-BGP topologies.....	10
7.	Security Considerations.....	13
8.	IANA Considerations.....	13
9.	References.....	14
9.1.	Normative References.....	14
9.2.	Informative References.....	14
10.	Acknowledgments.....	14
11.	Author's Addresses.....	15

Requirements for the graceful shutdown of BGP sessions

[1.](#) Conventions used in this document

The key words "MUST", "MUST NOT", "REQUIRED", "SHALL", "SHALL NOT", "SHOULD", "SHOULD NOT", "RECOMMENDED", "MAY", and "OPTIONAL" in this document are to be interpreted as described in [RFC 2119](#) [[RFC2119](#)].

[2.](#) Introduction

The BGP protocol is heavily used in Service Provider networks both for Internet and BGP/MPLS VPN services. For resiliency purposes, redundant routers and BGP sessions can be deployed to reduce the consequences of an AS Border Router or BGP session breakdown on customers' or peers' traffic.

We place ourselves in the context where a Service Provider performs a maintenance operation and needs to shut down one or multiple BGP peering link(s) or a whole ASBR. If an alternate path is available within the AS, the requirement is to avoid or reduce customer or peer traffic loss during the BGP convergence. Indeed, as an alternate path is available in the Autonomous System (AS), it should be made possible to reroute the customer or peer traffic on this backup path before the BGP session(s) is/are torn down, the nominal path withdrawn and the forwarding is interrupted on the nominal path.

The requirements also cover the subsequent re-establishment of the BGP session as even this "UP" case can currently trigger route loss and thus traffic loss at some routers.

Currently, BGP [[BGP-4](#)] and MP-BGP [[MP-BGP](#)] do not include any operation to gracefully withdraw a prefix while traffic toward that prefix could still be correctly forwarded. When a BGP session is taken down, BGP behaves as if it was a sudden link or router failure and withdraws the prefixes learnt over that session, which may

trigger traffic loss. There is no mechanism to advertise to its BGP peers that the prefix will soon be unreachable, while still being reachable. When applicable, such mechanism would reduce or prevent traffic loss. It would typically be applicable in case of a maintenance operation requiring the shutdown of a forwarding resource. Typical examples would be a link or line card maintenance, replacement or upgrade. It may also be applicable for a software upgrade as it may involve a firmware reset on the line cards and hence forwarding interruption.

The introduction of Route Reflectors as per [RR] to solve scalability issues bound to iBGP full-meshes has worsened the duration of routing convergence as some route reflectors may hide the back up path. Thus depending on RR topology more iBGP hops may be involved in the iBGP convergence.

Requirements for the graceful shutdown of BGP sessions

Note that these planned maintenance operations cannot be addressed by Graceful Restart extensions [GR] as GR only applies when the forwarding is preserved during the control plane restart. On the contrary, Graceful Shutdown applies when the forwarding is interrupted.

Note also that some protocols are already considering such graceful shutdown procedure (e.g. GMPLS in [RFC5817]).

A successful approach of such mechanism should minimize the loss of traffic in most foreseen maintenance situations.

3. Problem statement

As per [BGP-4], when one (or many) BGP session(s) are shut down, a BGP NOTIFICATION message is sent to the peer and the session is then closed. A protocol convergence is then triggered both by the local router and by the peer. Alternate paths to the destination are selected, if known. If those alternate paths are not known prior to the BGP session shutdown, additional BGP convergence steps are required in each AS to search for an alternate path.

This behavior is not satisfactory in a maintenance situation because the traffic that was directed towards the removed next-hops may be lost until the end of the BGP convergence. As it is a planned operation, a make before break solution should be made possible.

As maintenance operations are frequent in large networks

[Reliability], the global availability of the network is significantly impaired by this BGP maintenance issue.

3.1. Example of undesirable BGP routing behavior

To illustrate these problems, let us consider the following example where one customer router "CUST" is dual-attached to two SP routers "ASBR1" and "ASBR2".

ASBR1 and ASBR2 are in the same AS and owned by the same service provider. Both are iBGP client of the route reflector R1.

Requirements for the graceful shutdown of BGP sessions

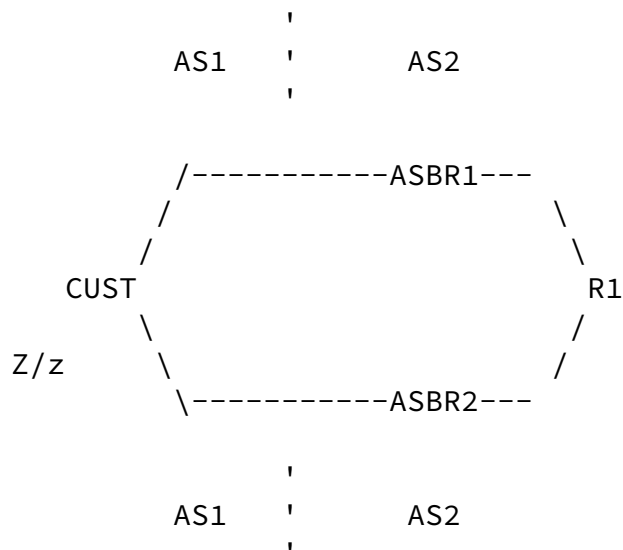

Before the maintenance, packets for destination Z/z use the CUST-ASBR1 link because R1 selects ASBR1's route based on the IGP cost.

Let's assume the service provider wants to shutdown the ASBR1-CUST link for maintenance purposes. Currently, when the shutdown is performed on ASBR1, the following steps are performed:

1. ASBR1 sends a withdraw to its route reflector R1 for the prefix Z/z.
2. R1 runs its decision process, selects the route from ASBR2 and advertises the new path to ASBR1.
3. ASBR1 runs its decision process and recovers the reachability of Z/z.

Traffic is lost between step 1 when ASBR1 loses its route and step 3 when it discovers a new path.

Note that this is a simplified description for illustrative purpose. In a bigger AS, multiple steps of BGP convergence may be required to find and select the best alternate path (e.g. ASBR1 is chosen based on a higher local pref, hierarchical route reflectors are used...). When multiple BGP routers are involved and plenty of prefixes are affected, the recovery process can take longer than applications requirements.

[3.2.](#) Causes of packet loss

The loss of packets during the maintenance has two main causes:

- lack of an alternate path on some routers
- transient routing inconsistency.

Some routers may lack an alternate path because another router is hiding the backup path. This router can be a route reflector only propagating the best path. Or the backup ASBR does not advertise the backup path because it prefers the nominal path. This lack of

Requirements for the graceful shutdown of BGP sessions

knowledge of the alternate path is the first target of this requirement draft.

Transient routing inconsistencies happen during iBGP convergence because all routers are not updating their RIB at the same time. This can lead to forwarding loops and then packet drops. This can be avoided by performing only one IP lookup on BGP routes in each AS and by using tunnels (e.g. MPLS LSP) to send packets between ASBRs.

[4.](#) Terminology

g-shut initiator: the router on which the session(s) shutdown is (are) performed for the maintenance.

g-shut neighbor: a router that peers with the g-shut initiator via (one of) the session(s) undergoing maintenance.

Affected prefixes: a prefix initially reached via the peering link(s) undergoing maintenance.

Affected router: a router reaching an affected prefix via a peering link undergoing maintenance.

Initiator AS: the autonomous system of the g-shut initiator router.

Neighbor AS(es): the autonomous system(s) of the g-shut neighbor router(s).

5. Goals and requirements

When a BGP session of the router under maintenance is shut down, the router removes the routes and then triggers the BGP convergence on its BGP peers. The goal of BGP graceful shutdown is to initiate the BGP convergence to find the alternate paths before the nominal paths are removed. As a result, before the nominal BGP session is shut down, all routers learn and use the alternate paths. Then the nominal BGP session can be shut down.

As a result, provided an alternate path is available in the AS, the packets are rerouted before the BGP session termination and fewer packets (possibly none) are lost during the BGP convergence process since at any time, all routers have a valid path.

Another goal is to minimize packet loss when the BGP session is re-established following the maintenance.

From the above goals we can derive the following requirements:

a) A mechanism to advertise the maintenance action to all affected routers is REQUIRED. Such mechanism may be either implicit or

Requirements for the graceful shutdown of BGP sessions

explicit. Note that affected routers can be located both in the local AS and in neighboring ASes.

b) An Internet wide convergence is OPTIONAL. However if the initiator AS and the neighbor AS(es) have a backup path, they MUST be able to gracefully converge before the nominal path is shut down.

c) The proposed solution SHOULD be applicable to any kind of BGP sessions (e-BGP, i-BGP, i-BGP route reflector client, e-BGP confederations, e-BGP multi hop, MultiProtocol BGP extension...) and any address family. If a BGP implementation allows closing a sub-set of AFIs carried in a MP-BGP session, this mechanism MAY be applicable to this sub-set of AFIs.

Depending on the session type (eBGP, iBGP...), there may be some variations in the proposed solution in order to fit the requirements.

The following cases should be handled in priority:

- The shutdown of an inter-AS link and therefore the shutdown of an eBGP session.
- The shutdown of an AS Border Router and therefore the shutdown of all its BGP sessions
- The shutdown of a customer access router and all of its BGP sessions. In BGP/MPLS VPN as per [\[VPN\]](#), this router is called a CE and the use of others protocols than BGP on the PE-CE access link should also be considered (static routes, RIPv2, OSPF, IS-IS...).

d) The proposed solution SHOULD NOT change the BGP convergence behavior for the ASes exterior to the maintenance process, namely ASes other than the initiator AS and it(s) neighbor AS(es).

e) An incremental deployment on a per AS or per BGP session basis SHOULD be made possible. In case of partial deployment the proposed solution SHOULD incrementally improve the maintenance process. The solution SHOULD bring improvements even when one of the two ASes does not support graceful shutdown. In particular, large Service Providers may not be able to upgrade all of the deployed customer premises access routers (CPE).

f) Redistribution or advertisement of (static) IP routes into BGP SHOULD also be covered.

g) The proposed solution MAY be designed in order to avoid transient forwarding loops. Indeed, forwarding loops increase packet transit delay and may lead to link saturation.

h) The specific procedure SHOULD end when the BGP session is closed. The procedure SHOULD be reverted, either automatically or manually, when the session is re-established. During this reversion procedure -when the session is brought up- the procedure SHOULD also minimize packet loss when the nominal path is installed and used

Requirements for the graceful shutdown of BGP sessions

again. In particular, it SHOULD be ensured that the backup path is not removed from the routing tables of the effected nodes before it learns the nominal path. In the end, once the planned maintenance is finished and the shutdown resource becomes available again, the nominal BGP routing MUST be reestablished.

i) The solution SHOULD be simple and simple to operate. Hence it MAY only cover a subset of the cases.

The metrics to evaluate and compare the proposed solutions are, in decreasing order of importance:

- The duration of the remaining loss of connectivity when the BGP session is brought down or up
- The applicability to a wide range of BGP and network topologies, especially those described in [section 6](#);
- The simplicity;
- The duration of transient forwarding loops;
- The additional load introduced in BGP (eg BGP messages sent to peer routers, peer ASes, the Internet).

[6](#). Reference Topologies

In order to benchmark the proposed solutions, some typical BGP topologies are detailed in this section. The solution drafts should state its applicability for each of these possible topologies.

However, solutions SHOULD be applicable to all possible BGP topologies and not only to these below examples. Note that this is a "SHOULD" rather than a "MUST" as a partial lightweight solution may be preferred to a full but more complex solution. Especially since some ISP may not be concerned by some topologies (e.g. confederations).

[6.1](#). E-BGP topologies

We describe here some frequent eBGP topologies that SHOULD be supported by the solution.

[6.1.1](#). 1 ASBR in AS1 connected to two ASBRs in the neighboring AS2

In this topology we have an asymmetric protection scheme between AS1 and AS2:

- On AS2 side, two different routers are used to connect to AS1.
- On AS1 side, one single router with two BGP sessions is used.

Requirements for the graceful shutdown of BGP sessions

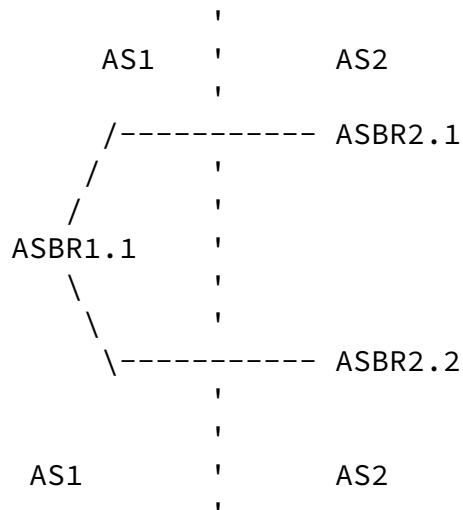

The requirements of [section 5](#) should be applicable to:

- Maintenance of one of the routers of AS2;
- Maintenance of one link between AS1 and AS2, performed either on an AS1 or AS2 router.

Note that in case of maintenance of the whole router, all its BGP session needs to be shutdown.

[6.1.2](#). 2 ASBRs in AS1 connected to 2 ASBRs in AS2

In this topology we have a symmetric protection scheme between AS1 and AS2: on both sides, two different routers are used to connect AS1 to AS2.

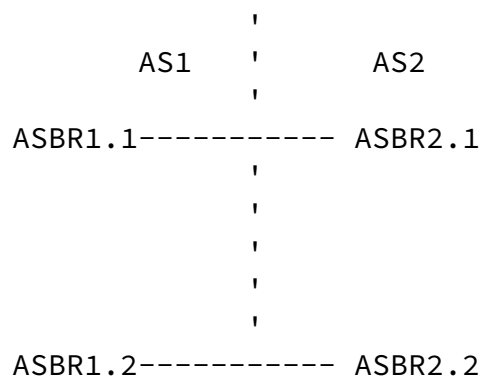

We describe here some frequent iBGP topologies that SHOULD be supported by the solution.

6.2.1. iBGP Full-Mesh

In this topology we have a full mesh of iBGP sessions:

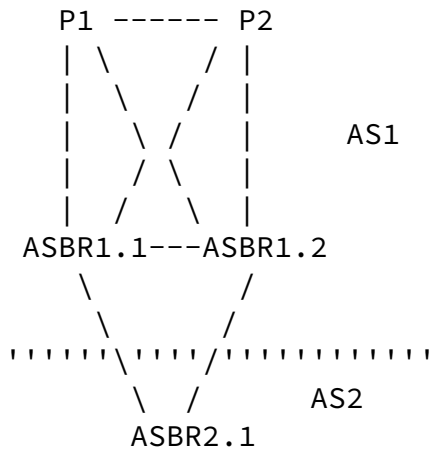

Requirements for the graceful shutdown of BGP sessions

When the session between ASBR1.1 and ASBR2.1 undergoes maintenance, it is required that all i-BGP peers of ASBR1.1 reroute traffic to ASBR1.2 before the session between ASBR1.1 and ASBR2.1 is shut down.

6.2.2. Route Reflector

In this topology, route reflectors are used to limit the number of i-BGP sessions.

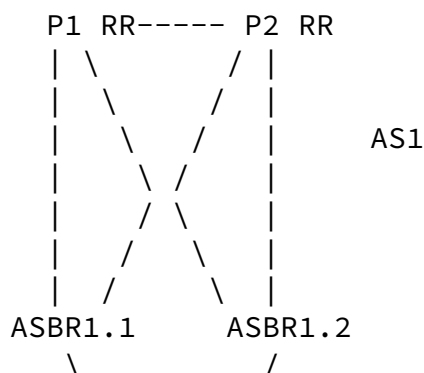



When the session between ASBR1.1 and ASBR2.1 undergoes maintenance, it is required that all BGP routers of AS1 reroute traffic to ASBR1.2 before the session between ASBR1.1 and ASBR2.1 is shut down.

6.2.3. hierarchical Route Reflector

In this topology, hierarchical route reflectors are used to limit the number of i-BGP sessions.

Requirements for the graceful shutdown of BGP sessions

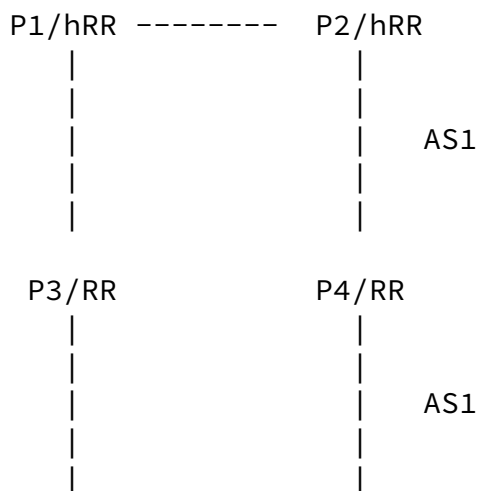

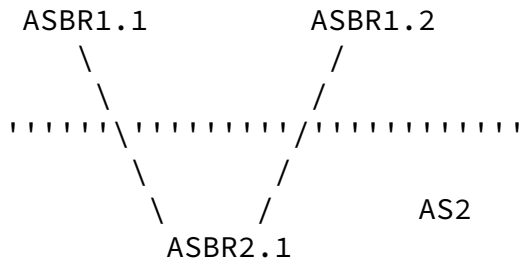

When the session between ASBR1.1 and ASBR2.1 undergoes maintenance, it is required that all BGP routers of AS1 reroute traffic to ASBR1.2 before the session between ASBR1.1 and ASBR2.1 is shut down.

[6.2.4. Confederations](#)

In this topology, a confederation of ASs is used to limit the number of i-BGP sessions. Moreover, RRs may be present in the member ASs of the confederation.

Confederations may be run with different sub-options. Regarding the IGP, each member AS can run its own IGP or they can all share the same IGP. Regarding BGP, `local_pref` may or may not cross the member AS boundaries.

A solution should support the shutdown of eBGP sessions between member-ASs in the confederation in addition to the shutdown of eBGP sessions between a member-AS and an AS outside of the confederation.

Requirements for the graceful shutdown of BGP sessions

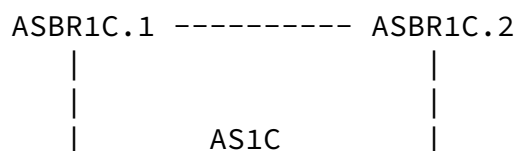

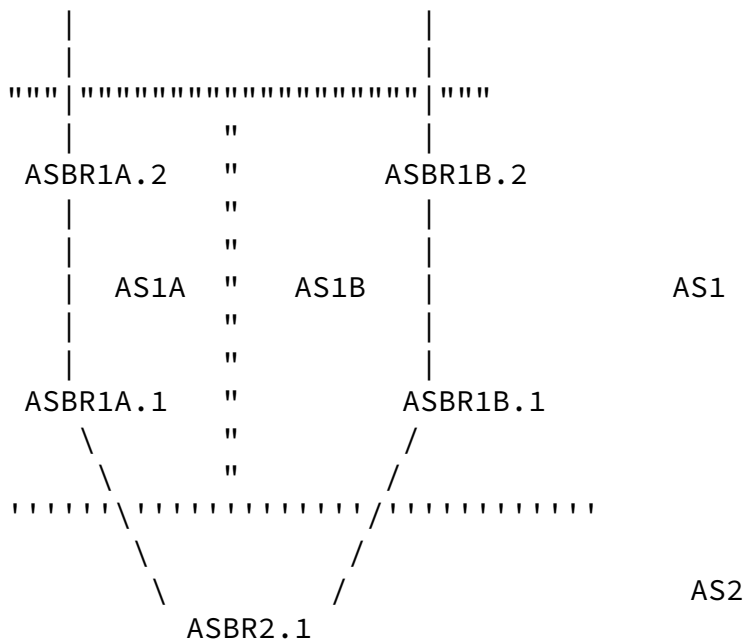

In the above figure, member-AS AS1A, AS1B, AS1C belong to a confederation of ASs in AS1. AS1A and AS1B are connected to AS2.

In normal operation, for the traffic toward AS2,

- . AS1A sends the traffic directly to AS2 through ASBR1A.1
- . AS1B sends the traffic directly to AS2 through ASBR1B.1
- . AS1C load balances the traffic between AS1A and AS1B

When the session between ASBR1A.1 and ASBR2.1 undergoes maintenance, it is required that all BGP routers of AS1 reroute traffic to ASBR1B.1 before the session between ASBR1A.1 and ASBR2.1 is shut down.

7. Security Considerations

Security considerations MUST be addressed by the proposed solutions.

The solution SHOULD NOT increase the ability for one AS to selectively influence routing decision in the peer AS (inbound TE) outside the case of the BGP session shutdown. Otherwise, the peer AS SHOULD have means to detect such behavior.

8. IANA Considerations

This document has no actions for IANA.

Requirements for the graceful shutdown of BGP sessions

9. References

9.1. Normative References

[RFC2119] Bradner, S., "Key words for use in RFCs to Indicate Requirement Levels", [BCP 14](#), [RFC 2119](#), March 1997.

[BGP-4] Y. Rekhter, T. Li, "A Border Gateway protocol 4 (BGP)", [RFC 4271](#), January 2006.

[MP-BGP] T. Bates, R. Chandra, D. Katz, Y. Rekhter, "Multiprotocol Extensions for BGP-4", [RFC 4760](#) January 2007.

[RR] T. Bates, E. Chen, R. Chandra
"BGP Route Reflection: An Alternative to Full Mesh Internal BGP (IBGP)", [RFC 4456](#) April 2006.

[VPN] E. Rosen, Y. Rekhter
"BGP/MPLS IP Virtual Private Networks (VPNs)", [RFC 4364](#)
February 2006.

9.2. Informative References

[RFC5817] Z. Ali, J.P. Vasseur, A. Zamfir and J. Newton
"Graceful Shutdown in MPLS and Generalized MPLS Traffic Engineering Networks", [RFC 5817](#) April 2010.

[GR] S. Sangli, E. Chen, R. Fernando, J. Scudder, Y. Rekhter
"Graceful Restart Mechanism for BGP", [RFC 4724](#) January 2007.

[Reliability] Network Strategy Partners, LLC.
"Reliable IP Nodes: A prerequisite to profitable IP services",
November 2002. http://www.nspllc.com/NewPages/Reliable_IP_Nodes.pdf

10. Acknowledgments

This draft is mostly an updated version of [draft-dubois-bgp-pm-reqs-02.txt](#).

Authors would like to thank Nicolas Dubois, Benoit Fondeviole, Christian Jacquenet, Olivier Bonaventure, Steve Uhlig, Xavier Vinet, Vincent Gillet, Jean-Louis le Roux and Pierre Alain Coste for the useful discussions on this subject, their review and comments.

This draft has been partly sponsored by the European project IST AGAVE.

Requirements for the graceful shutdown of BGP sessions

Authors' Addresses

Bruno Decraene
France Telecom
38-40 rue du General Leclerc
92794 Issy Moulineaux cedex 9
France

Email: bruno.decraene@orange-ftgroup.com

Pierre Francois
Universite catholique de Louvain
Place Ste Barbe, 2
Louvain-la-Neuve 1348
BE

Email: francois@info.ucl.ac.be

Cristel Pelsser
Internet Initiative Japan
Jinbocho Mitsui Building
1-105 Kanda jinbo-cho
Chiyoda-ku, Tokyo 101-0051
Japan

Email: cristel@iij.ad.jp

Zubair Ahmad
Orange Business Services
13775 McLearen Road, Oak Hill VA 20171
USA

Email: zubair.ahmad@orange-ftgroup.com

Antonio Jose Elizondo Armengol

Division de Analisis Tecnologicos
Technology Analysis Division
Telefonica I+D
C/ Emilio Vargas 6
28043, Madrid

E-mail: ajea@tid.es

Tomonori Takeda
NTT Corporation
9-11, Midori-Cho 3 Chrome

Decraene

Expires December 2010

[Page 15]

Requirements for the graceful shutdown of BGP sessions

Musashino-Shi, Tokyo 180-8585
Japan

Email: takeda.tomonori@lab.ntt.co.jp

Decraene

Expires December 2010

[Page 16]