

Network Working Group  
Internet-Draft  
Expires: January 12, 2006

J. Laganier  
DoCoMo Euro-Labs  
L. Eggert  
NEC  
July 11, 2005

Host Identity Protocol (HIP) Rendezvous Extension  
draft-ietf-hip-rvs-03

Status of this Memo

By submitting this Internet-Draft, each author represents that any applicable patent or other IPR claims of which he or she is aware have been or will be disclosed, and any of which he or she becomes aware will be disclosed, in accordance with [Section 6 of BCP 79](#).

Internet-Drafts are working documents of the Internet Engineering Task Force (IETF), its areas, and its working groups. Note that other groups may also distribute working documents as Internet-Drafts.

Internet-Drafts are draft documents valid for a maximum of six months and may be updated, replaced, or obsoleted by other documents at any time. It is inappropriate to use Internet-Drafts as reference material or to cite them other than as "work in progress."

The list of current Internet-Drafts can be accessed at <http://www.ietf.org/ietf/lid-abstracts.txt>.

The list of Internet-Draft Shadow Directories can be accessed at <http://www.ietf.org/shadow.html>.

This Internet-Draft will expire on January 12, 2006.

Copyright Notice

Copyright (C) The Internet Society (2005).

Abstract

This document defines a rendezvous extension for the Host Identity Protocol (HIP). The rendezvous extension extends HIP and the HIP registration extension for initiating communication between HIP nodes via HIP rendezvous servers. Rendezvous servers improve reachability and operation when HIP nodes are multi-homed or mobile.

## Table of Contents

<a href="#">1.</a>	Introduction . . . . .	<a href="#">3</a>
<a href="#">2.</a>	Terminology . . . . .	<a href="#">3</a>
<a href="#">3.</a>	Overview of Rendezvous Server Operation . . . . .	<a href="#">4</a>
<a href="#">3.1</a>	Diagram Notation . . . . .	<a href="#">5</a>
<a href="#">3.2</a>	Rendezvous Client Registration . . . . .	<a href="#">5</a>
<a href="#">3.3</a>	Relaying the Base Exchange . . . . .	<a href="#">6</a>
<a href="#">4.</a>	Rendezvous Server Extensions . . . . .	<a href="#">7</a>
<a href="#">4.1</a>	RENDEZVOUS Registration Type . . . . .	<a href="#">7</a>
<a href="#">4.2</a>	Parameter Formats and Processing . . . . .	<a href="#">7</a>
<a href="#">4.2.1</a>	RVS_HMAC Parameter . . . . .	<a href="#">7</a>
<a href="#">4.2.2</a>	FROM Parameter . . . . .	<a href="#">8</a>
<a href="#">4.2.3</a>	VIA_RVS Parameter . . . . .	<a href="#">9</a>
<a href="#">4.3</a>	Modified Packets Processing . . . . .	<a href="#">9</a>
<a href="#">4.3.1</a>	Processing Outgoing I1 Packets . . . . .	<a href="#">9</a>
<a href="#">4.3.2</a>	Processing Incoming I1 packets . . . . .	<a href="#">10</a>
<a href="#">4.3.3</a>	Processing Outgoing R1 Packets . . . . .	<a href="#">10</a>
<a href="#">4.3.4</a>	Processing Incoming R1 packets . . . . .	<a href="#">10</a>
<a href="#">5.</a>	Security Considerations . . . . .	<a href="#">10</a>
<a href="#">6.</a>	IANA Considerations . . . . .	<a href="#">11</a>
<a href="#">7.</a>	Acknowledgments . . . . .	<a href="#">11</a>
<a href="#">8.</a>	References . . . . .	<a href="#">12</a>
<a href="#">8.1</a>	Normative References . . . . .	<a href="#">12</a>
<a href="#">8.2</a>	Informative References . . . . .	<a href="#">12</a>
	Authors' Addresses . . . . .	<a href="#">13</a>
<a href="#">A.</a>	Document Revision History . . . . .	<a href="#">14</a>
	Intellectual Property and Copyright Statements . . . . .	<a href="#">15</a>

## 1. Introduction

The Host Identity Protocol architecture [[I-D.ietf-hip-arch](#)] introduces the rendezvous mechanism to help a HIP node to contact a frequently moving HIP node. The rendezvous mechanism involves a third party, the rendezvous server (RVS), which serves as an initial contact point ("rendezvous point") for its clients. The clients of an RVS are HIP nodes that use the HIP Registration Protocol [[I-D.koponen-hip-registration](#)] to register their HIT->IP address mappings with the RVS. After this registration, other HIP nodes can initiate a base exchange using the IP address of the RVS instead of the current IP address of the node they attempt to contact. Essentially, the clients of an RVS become reachable at the RVS' IP addresses. Peers can initiate a HIP base exchange with the IP address of the RVS, which will relay this initial communication such that the base exchange may successfully complete.

## 2. Terminology

This section defines terms used throughout the remainder of this specification.

The key words "MUST", "MUST NOT", "REQUIRED", "SHALL", "SHALL NOT", "SHOULD", "SHOULD NOT", "RECOMMENDED", "MAY", and "OPTIONAL" in this document are to be interpreted as described in [RFC 2119](#) [[RFC2119](#)].

In addition to the terminology defined in [[I-D.koponen-hip-registration](#)], this document defines and uses the following terms:

### Rendezvous Service

A HIP service provided by a rendezvous server to its rendezvous clients. The rendezvous server offers to relay some of the arriving base exchange packets between the initiator and responder.

### Rendezvous Server (RVS)

A HIP registrar providing rendezvous service.

#### Rendezvous Client

A HIP requester that has registered for rendezvous service at a rendezvous server.

#### Rendezvous Registration

A HIP registration for rendezvous service, established between a rendezvous server and a rendezvous client.

### 3. Overview of Rendezvous Server Operation

Figure 1 shows a simple HIP base exchange without a rendezvous server, in which the initiator initiates the exchange directly with the responder by sending an I1 packet to the responder's IP address, as per the HIP base specification [[I-D.ietf-hip-base](#)].

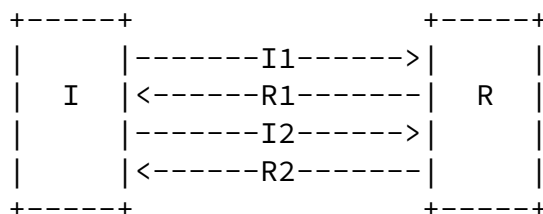

Figure 1: HIP base exchange without rendezvous server.

Proposed extensions for mobility and multi-homing [[I-D.ietf-hip-mm](#)] allow a HIP node to notify its peers about changes in its set of IP addresses. These extensions presumes initial reachability of the two nodes with respect to each other.

However, such a HIP node MAY also want to be reachable to other future correspondent peers that are unaware of its location change. The HIP architecture [[I-D.ietf-hip-arch](#)] introduces rendezvous servers with whom a HIP node MAY register its host identity tags (HITs) and current IP addresses. An RVS relays HIP packets arriving for these HITs to the node's registered IP addresses. When a HIP node has registered with an RVS, it SHOULD record the IP address of its RVS in its DNS record, using the HIPRVS DNS record type defined

in [[I-D.ietf-hip-dns](#)].

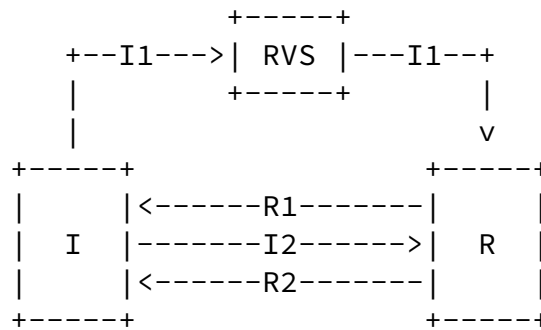

Figure 2: HIP base exchange with a rendezvous server.

Figure 2 shows a HIP base exchange involving a rendezvous server. It is assumed that HIP node R previously registered its HITs and current IP addresses with the RVS, using the HIP registration protocol [[I-D.koponen-hip-registration](#)]. When the initiator I tries to establish contact with the responder R, it must send the I1 of the

base exchange either to one of R's IP addresses (if known via DNS or other means) or to one of R's rendezvous servers instead. Here, I obtains the IP address of R's rendezvous server from R's DNS record and then sends the I1 packet of the HIP base exchange to RVS. RVS, noticing that the HIT contained in the arriving I1 packet is not one of its own, MUST check its current registrations to determine if it needs to relay the packets. Here, it determines that the HIT belongs to R and then relays the I1 packet to the registered IP address. R then completes the base exchange without further assistance from RVS by sending an R1 directly to the I's IP address, as obtained from the I1 packet. In this specification the client of the RVS is always the responder. However, there might be reasons to allow a client to initiate a base exchange through its own RVS, like NAT and firewall traversal. This specification does not address such scenarios which should be specified in other documents.

### 3.1 Diagram Notation

Notation	Significance
I, R	I and R are the respective source and destination IP

addresses in the IP header.

HIT-I, HIT-R	HIT-I and HIT-R are the initiator's and the responder's HITs in the packet, respectively.
REG_REQ	A REG_REQUEST parameter is present in the HIP header.
REG_RES	A REG_RESPONSE parameter is present in the HIP header.
FROM:I	A FROM parameter containing the IP address I is present in the HIP header.
RVS_HMAC	A RVS_HMAC parameter containing a HMAC keyed with the appropriate registration key is present in the HIP header.
VIA:RVS	A VIA_RVS parameter containing the IP address RVS of a rendezvous server is present in the HIP header.

### [3.2](#) Rendezvous Client Registration

Before a rendezvous server starts to relay HIP packets to a rendezvous client, the rendezvous client needs to register with it to receive rendezvous service by using the HIP registration extension [[I-D.koponen-hip-registration](#)] as illustrated in the following

schema:

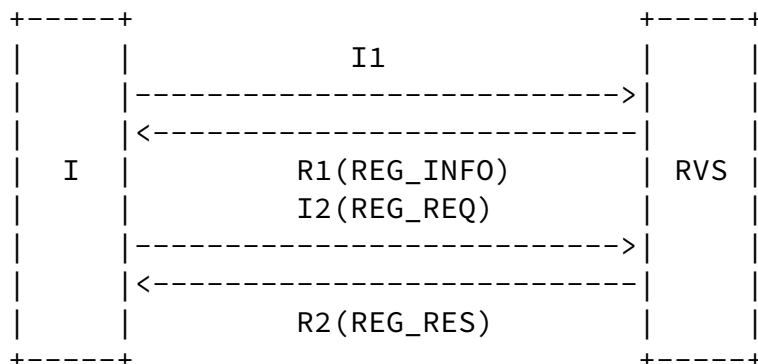

### [3.3](#) Relaying the Base Exchange

If a HIP node and one of its rendezvous servers have a rendezvous registration, the rendezvous servers relay inbound I1 packets that contain one of the client's HITs by rewriting the IP header. They replace the destination IP address of the I1 packet with one of the IP addresses of the owner of the HIT, i.e., the rendezvous client. They MUST also recompute the IP checksum accordingly.

Because of egress filtering on the path from the RVS to the client [RFC2827][RFC3013], a HIP rendezvous server SHOULD replace the source IP address, i.e., the IP address of I, with one of its own IP addresses. The replacement IP address SHOULD be chosen according to [RFC1122] and, when IPv6 is used, to [RFC3484]. Because this replacement conceals the initiator's IP address, the RVS MUST append a FROM parameter containing the original source IP address of the packet. This FROM parameter MUST be integrity protected by a RVS\_HMAC keyed with the corresponding rendezvous registration integrity key [I-D.koponen-hip-registration].

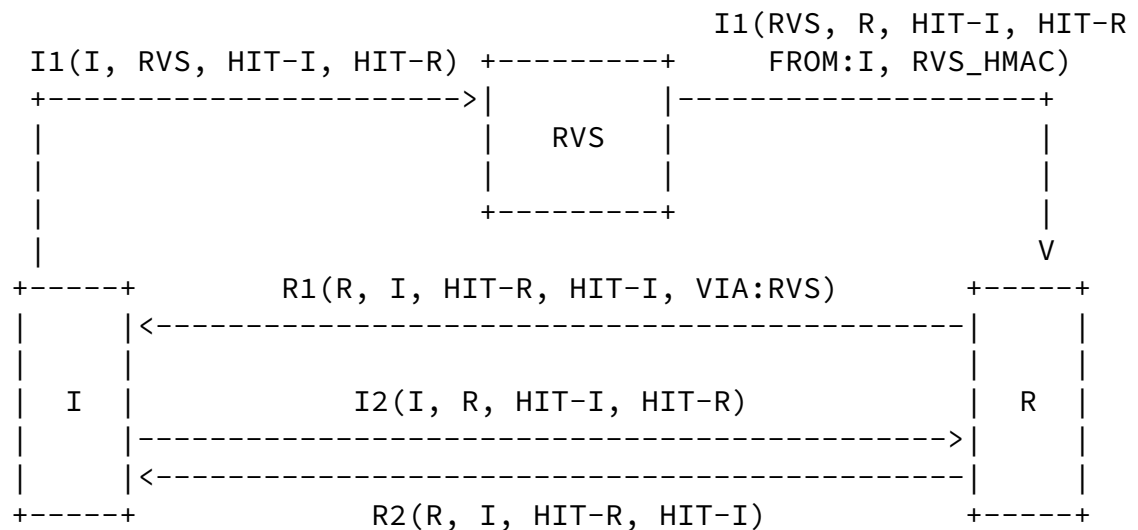

This modification of HIP packets at a rendezvous server can be problematic because the HIP protocol uses integrity checks. Because the I1 does not include HMAC or SIGNATURE parameters, these two end-to-end integrity checks are unaffected by the operation of rendezvous servers.

The RVS SHOULD verify the checksum field of an I1 packet before doing any modifications. After modification, it MUST recompute the

checksum field using the updated HIP header, which possibly included new FROM and RVS\_HMAC parameters, and a pseudo-header containing the updated source and destination IP addresses. This enables the responder to validate the checksum of the I1 packet "as is", without having to parse any FROM parameters.

#### [4. Rendezvous Server Extensions](#)

The following sections describe extensions to the HIP registration protocol [[I-D.koponen-hip-registration](#)], allowing a HIP node to register with a rendezvous server for rendezvous service and notify the RVS aware of changes to its current location. It also describes an extension to the HIP protocol [[I-D.ietf-hip-base](#)] itself, allowing establishment of HIP associations via one or more HIP rendezvous server(s).

##### [4.1 RENDEZVOUS Registration Type](#)

This specification defines an additional registration for the HIP registration protocol [[I-D.koponen-hip-registration](#)] that allows registering with a rendezvous server for rendezvous service.

Number	Registration Type
1	RENDEZVOUS

##### [4.2 Parameter Formats and Processing](#)

###### [4.2.1 RVS\\_HMAC Parameter](#)

The RVS\_HMAC is a non-critical parameter whose only difference with the HMAC parameter defined in [[I-D.ietf-hip-base](#)] is its "type" code. This change causes it to be located after the FROM parameter (as opposed to the HMAC):



Length 20  
HMAC 160 low order bits of a HMAC keyed with the appropriate HIP integrity key (HIP\_lg or HIP\_gl), established when rendezvous registration happened. This HMAC is computed over the HIP packet, excluding RVS\_HMAC and any following parameters. The "checksum" field MUST be set to zero and the HIP header length in the HIP common header MUST be calculated not to cover any excluded parameter when the "authenticator" field is calculated.

To allow a rendezvous client and its RVS to verify the integrity of packets flowing between them, both SHOULD protect packets with an added RVS\_HMAC parameter keyed with the HIP\_lg or HIP\_gl integrity key established while registration occurred. A valid RVS\_HMAC SHOULD be present on every packets flowing between a client and a server and MUST be present when a FROM parameters is processed.

#### 4.2.2 FROM Parameter

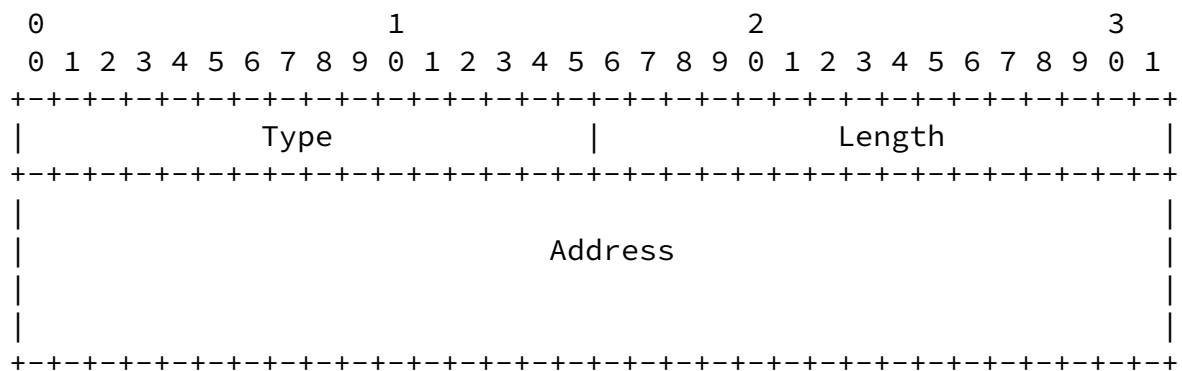

Type [ TBD by IANA (65498 = 2<sup>16</sup> - 2<sup>5</sup> - 2) ]  
Length 16  
Address An IPv6 address or an IPv4-in-IPv6 format IPv4 address.

A rendezvous server MUST add a FROM parameter containing the original source IP address of a HIP packet whenever the source IP address in the IP header is rewritten. If one or more FROM parameters are already present, the new FROM parameter MUST be appended after the existing ones.

Whenever an RVS inserts a FROM parameter, it MUST insert an RVS\_HMAC protecting the packet integrity, especially the IP address included in the FROM parameter.



When an RVS rewrites the source IP address of an I1 packet due to

egress filtering, it MUST add a FROM parameter to the I1 that contains the initiator's source IP address. This FROM parameter MUST be protected by an RVS\_HMAC keyed with the integrity key established at rendezvous registration.

#### [4.3.2](#) Processing Incoming I1 packets

When a rendezvous server receives an I1 whose destination HIT is not its own, it consults its registration database to find a registration for the rendezvous service established by the HIT owner. If it finds an appropriate registration, it relays the packet to the registered IP address. If it does not find an appropriate registration, it drops the packet.

A rendezvous server SHOULD interpret any incoming opportunistic I1 (i.e., an I1 with a NULL destination HIT) as an I1 addressed to itself and SHOULD NOT attempt to relay it to one of its clients.

When a rendezvous client receives an I1, it MUST validate any present RVS\_HMAC parameter. If the RVS\_HMAC cannot be verified, the packet SHOULD be dropped. If the RVS\_HMAC cannot be verified and a FROM parameter is present, the packet MUST be dropped.

A rendezvous client acting as responder SHOULD drop opportunistic I1s that include a FROM parameter, because this indicates that the I1 has been relayed.

#### [4.3.3](#) Processing Outgoing R1 Packets

When a responder replies to an I1 relayed via an RVS, it MUST append to the regular R1 header a VIA\_RVS parameter containing the IP addresses of the traversed RVS's.

#### [4.3.4](#) Processing Incoming R1 packets

The HIP base specification [[I-D.ietf-hip-base](#)] mandates that a system receiving an R1 MUST first check to see if it has sent an I1 to the originator of the R1 (i.e., it is in state I1-SENT). When the R1 is replying to a relayed I1, this check SHOULD be based on HITs only.

In case the IP addresses are also checked, then the source IP address MUST be checked against the IP address included in the VIA\_RVS parameter.

## 5. Security Considerations

This section discusses the known threats introduced by these HIP extensions and implications on the overall security of HIP. In particular, it argues that the extensions described in this document

Laganier & Eggert

Expires January 12, 2006

[Page 10]

---

Internet-Draft

HIP Rendezvous Extension

July 2005

do not introduce additional threats to the Host Identity Protocol.

It is difficult to encompass the whole scope of threats introduced by rendezvous servers, because their presence has implications both at the IP and HIP layers. In particular, these extensions might allow for redirection, amplification and reflection attacks at the IP layer, as well as attacks on the HIP layer itself, for example, man-in-the-middle attacks against the HIP base exchange.

If an initiator has a priori knowledge of the responder's host identity when it first contacts it via an RVS, it has a means to verify the signatures in the HIP base exchange, which is known to be thus resilient to man-in-the-middle attacks.

If an initiator does not have a priori knowledge of the responder's host identity (so-called "opportunistic initiators"), it is almost impossible to defend the HIP exchange against these attacks, because the public keys exchanged cannot be authenticated. The only approach would be to mitigate hijacking threats on HIP state by requiring an R1 answering an opportunistic I1 to come from the same IP address that originally sent the I1. This procedure retains a level of security which is equivalent to what exists in the Internet today.

However, for reasons of simplicity, this specification does not allow to establish a HIP association via a rendezvous server in an opportunistic manner.

## 6. IANA Considerations

This section is to be interpreted according to [[RFC2434](#)].

This document updates the IANA Registry for HIP Parameters Types by

assigning new HIP Parameter Types values for the new HIP Parameters defined in [Section 4.2](#):

- o RVS\_HMAC (defined in [Section 4.2.1](#))
- o FROM (defined in [Section 4.2.2](#))
- o VIA\_RVS (defined in [Section 4.2.3](#))

## [7](#). Acknowledgments

The following people have provided thoughtful and helpful discussions and/or suggestions that have improved this document: Marcus Brunner, Tom Henderson, Miika Komu, Mika Kousa, Pekka Nikander, Justino Santos, Simon Schuetz, Tim Shepard, Kristian Slavov, Martin

Laganier & Eggert Expires January 12, 2006 [Page 11]

---

Internet-Draft HIP Rendezvous Extension July 2005

Stiemerling and Juergen Quittek.

Julien Laganier and Lars Eggert are partly funded by Ambient Networks, a research project supported by the European Commission under its Sixth Framework Program. The views and conclusions contained herein are those of the authors and should not be interpreted as necessarily representing the official policies or endorsements, either expressed or implied, of the Ambient Networks project or the European Commission.

## [8](#). References

### [8.1](#) Normative References

[I-D.ietf-hip-base]

Moskowitz, R., "Host Identity Protocol",  
[draft-ietf-hip-base-03](#) (work in progress), June 2005.

[I-D.ietf-hip-dns]

Nikander, P. and J. Laganier, "Host Identity Protocol (HIP) Domain Name System (DNS) Extensions",  
[draft-ietf-hip-dns-01](#) (work in progress), February 2005.

[I-D.koponen-hip-registration]

Koponen, T. and L. Eggert, "Host Identity Protocol (HIP)

Registration Extension", [draft-koponen-hip-registration-00](#) (work in progress), February 2005.

- [RFC1122] Braden, R., "Requirements for Internet Hosts - Communication Layers", STD 3, [RFC 1122](#), October 1989.
- [RFC2119] Bradner, S., "Key words for use in RFCs to Indicate Requirement Levels", [BCP 14](#), [RFC 2119](#), March 1997.
- [RFC2434] Narten, T. and H. Alvestrand, "Guidelines for Writing an IANA Considerations Section in RFCs", [BCP 26](#), [RFC 2434](#), October 1998.
- [RFC3484] Draves, R., "Default Address Selection for Internet Protocol version 6 (IPv6)", [RFC 3484](#), February 2003.

## [8.2](#) Informative References

[I-D.ietf-hip-arch]  
Moskowitz, R., "Host Identity Protocol Architecture", [draft-ietf-hip-arch-02](#) (work in progress), January 2005.

[I-D.ietf-hip-mm]

Laganier & Eggert Expires January 12, 2006 [Page 12]

---

Internet-Draft HIP Rendezvous Extension July 2005

Nikander, P., "End-Host Mobility and Multi-Homing with Host Identity Protocol", [draft-ietf-hip-mm-01](#) (work in progress), February 2005.

- [RFC1498] Saltzer, J., "On the Naming and Binding of Network Destinations", [RFC 1498](#), August 1993.
- [RFC2827] Ferguson, P. and D. Senie, "Network Ingress Filtering: Defeating Denial of Service Attacks which employ IP Source Address Spoofing", [BCP 38](#), [RFC 2827](#), May 2000.
- [RFC3007] Wellington, B., "Secure Domain Name System (DNS) Dynamic Update", [RFC 3007](#), November 2000.
- [RFC3013] Killalea, T., "Recommended Internet Service Provider Security Services and Procedures", [BCP 46](#), [RFC 3013](#), November 2000.

## Authors' Addresses

Julien Laganier  
DoCoMo Communications Laboratories Europe GmbH  
Landsberger Strasse 312  
Munich 80687  
Germany

Phone: +49 89 56824 231  
Email: [julien.ietf@laposte.net](mailto:julien.ietf@laposte.net)  
URI: <http://www.docomolab-euro.com/>

Lars Eggert  
NEC Network Laboratories  
Kurfuerstenanlage 36  
Heidelberg 69115  
Germany

Phone: +49 6221 90511 43  
Fax: +49 6221 90511 55  
Email: [lars.eggert@netlab.nec.de](mailto:lars.eggert@netlab.nec.de)  
URI: <http://www.netlab.nec.de/>

Laganier & Eggert

Expires January 12, 2006

[Page 13]

---

Internet-Draft

HIP Rendezvous Extension

July 2005

## [Appendix A](#). Document Revision History

Revision	Comments
03	Removed architectural discussions. Fixed some requirements keywords.
02	Removed multiple relaying techniques but simple I1 header rewriting. Updated new HIP parameters type numbers (consistent with new layout and assigning rules from <a href="#">draft-ietf-hip-base</a> .) Updated IANA

	Considerations.
01	Splitted out the registration sub-protocol. Simplify typology of relaying techniques (keep only TUNNEL, REWRITE, BIDIRECTIONAL). Rewrote IANA Considerations.
00	Initial version as a HIP WG item.

#### Intellectual Property Statement

The IETF takes no position regarding the validity or scope of any Intellectual Property Rights or other rights that might be claimed to



pertain to the implementation or use of the technology described in this document or the extent to which any license under such rights might or might not be available; nor does it represent that it has made any independent effort to identify any such rights. Information on the procedures with respect to rights in RFC documents can be found in [BCP 78](#) and [BCP 79](#).

Copies of IPR disclosures made to the IETF Secretariat and any assurances of licenses to be made available, or the result of an attempt made to obtain a general license or permission for the use of such proprietary rights by implementers or users of this specification can be obtained from the IETF on-line IPR repository at <http://www.ietf.org/ipr>.

The IETF invites any interested party to bring to its attention any copyrights, patents or patent applications, or other proprietary rights that may cover technology that may be required to implement this standard. Please address the information to the IETF at [ietf-ipr@ietf.org](mailto:ietf-ipr@ietf.org).

#### Disclaimer of Validity

This document and the information contained herein are provided on an "AS IS" basis and THE CONTRIBUTOR, THE ORGANIZATION HE/SHE REPRESENTS OR IS SPONSORED BY (IF ANY), THE INTERNET SOCIETY AND THE INTERNET ENGINEERING TASK FORCE DISCLAIM ALL WARRANTIES, EXPRESS OR IMPLIED, INCLUDING BUT NOT LIMITED TO ANY WARRANTY THAT THE USE OF THE INFORMATION HEREIN WILL NOT INFRINGE ANY RIGHTS OR ANY IMPLIED WARRANTIES OF MERCHANTABILITY OR FITNESS FOR A PARTICULAR PURPOSE.

#### Copyright Statement

Copyright (C) The Internet Society (2005). This document is subject to the rights, licenses and restrictions contained in [BCP 78](#), and except as set forth therein, the authors retain all their rights.

#### Acknowledgment

Funding for the RFC Editor function is currently provided by the Internet Society.