

MIF
Internet-Draft
Intended status: Informational
Expires: August 19, 2014

D. Liu
China Mobile
Ted. Lemon
Nominum
Yuri. Ismailov
Ericsson
Z. Cao
China Mobile
February 15, 2014

MIF API consideration
draft-ietf-mif-api-extension-05

Abstract

Hosts may connect to the internet using more than one network API at a time, or to a single network on which service is provided by more than one provider. Existing APIs are inadequate to allow applications to successfully use the network in this environment. This document presents a new abstract API that provides the minimal set of messages required to enable an application to communicate successfully in this environment.

Status of This Memo

This Internet-Draft is submitted in full conformance with the provisions of [BCP 78](#) and [BCP 79](#).

Internet-Drafts are working documents of the Internet Engineering Task Force (IETF). Note that other groups may also distribute working documents as Internet-Drafts. The list of current Internet-Drafts is at <http://datatracker.ietf.org/drafts/current/>.

Internet-Drafts are draft documents valid for a maximum of six months and may be updated, replaced, or obsoleted by other documents at any time. It is inappropriate to use Internet-Drafts as reference material or to cite them other than as "work in progress."

This Internet-Draft will expire on August 19, 2014.

Copyright Notice

Copyright (c) 2014 IETF Trust and the persons identified as the document authors. All rights reserved.

This document is subject to [BCP 78](#) and the IETF Trust's Legal Provisions Relating to IETF Documents

(<http://trustee.ietf.org/license-info>) in effect on the date of publication of this document. Please review these documents carefully, as they describe your rights and restrictions with respect to this document. Code Components extracted from this document must include Simplified BSD License text as described in Section 4.e of the Trust Legal Provisions and are provided without warranty as described in the Simplified BSD License.

Table of Contents

- [1. Introduction](#) [2](#)
- [2. Conventions used in this document](#) [3](#)
- [3. MIF API Concept](#) [3](#)
 - [3.1. Provisioning Domains](#) [4](#)
 - [3.2. MIF API Elements](#) [4](#)
 - [3.2.1. Application Element](#) [5](#)
 - [3.2.2. High Level API](#) [5](#)
 - [3.2.3. MIF API](#) [6](#)
 - [3.2.4. Communications API](#) [6](#)
 - [3.2.5. Network Link API](#) [6](#)
 - [3.2.6. MIF API communication model](#) [7](#)
 - [3.2.7. MIF Messages](#) [7](#)
 - [3.3. Example Usage](#) [14](#)
- [4. Security Considerations](#) [16](#)
- [5. IANA Considerations](#) [16](#)
- [6. Acknowledgments](#) [16](#)
- [7. References](#) [16](#)
 - [7.1. Normative References](#) [16](#)
 - [7.2. Informative References](#) [16](#)
- Authors' Addresses [17](#)

1. Introduction

Traditionally, applications that communicate on the network have done so over a single network link, which is provided by a single service provider. However, this operating environment is now the exception rather than the rule. Most devices now have multiple wireless interfaces that are, in practice, connected to networks operated by different providers. These networks may or may not have different reachability characteristics with respect to any given service an application may wish to connect to.

For example, consider a typical modern host with two wireless interfaces: a wireless interface connected to a broadband network, and another connected to some kind of cellular network. The same host may also have a wired interface which is sometimes connected to a third broadband link. It is also quite common for hosts to have

VPN links that are configured, for example, for access to corporate networks, or for access to network privacy services.

As a result, it is now quite typical that a program attempting to communicate in such an environment will be presented with conflicting configuration information from more than one provider. In addition, the cost of bandwidth on different links and the power required by those links may require consideration.

The API specified in this document is intended to describe the minimal complete set of API calls required to implement higher level APIs that solve these problems. It is not expected that applications will be implemented to this API, although it should be possible to do so. Rather, we expect this API to be used as a basis for building higher-level APIs that provide domain-specific solutions to these problems. The reason for specifying a lower-level API is to enable any arbitrary domain-specific API to be implemented, since no single higher-level API is likely to satisfy the needs of every application.

The API specified here is an abstract API. This means that we specify the functionality that is required to implement the API, but we do not provide specific bindings for any programming language: these are left up to the implementation. The API is described in terms of messages sent and messages received, rather than in terms of procedure calls, because it is necessary to be able to interleave these messages; a procedure call API necessarily precludes interleaving.

This document is intended to be read and used as a checklist by operating system vendors who are interested in providing adequate functionality to applications that must run on hosts in environments like the ones described here. It should also be useful to purchasers of devices that must operate in such environments, so that they can tell if they are getting a device that can actually succeed in these environments.

2. Conventions used in this document

The key words "MUST", "MUST NOT", "REQUIRED", "SHALL", "SHALL NOT", "SHOULD", "SHOULD NOT", "RECOMMENDED", "MAY", and "OPTIONAL" in this document are to be interpreted as described in [RFC 2119](#) [[RFC2119](#)].

3. MIF API Concept

The MIF API is intended to deal with situations where more than one interface may be active at a time. It must also deal with situations where a single interface is connected to a link that provides more

than one type of network service. The most common example of this that we expect is a dual-stack network configuration.

3.1. Provisioning Domains

Document [[I-D.ietf-mif-mpvd-arch](#)] defines Provisioning Domain (PvD) architecture and its associated mechanism, such as PvD identity/naming concept, conveying mechanism etc. According to [[I-D.ietf-mif-mpvd-arch](#)], a provisioning domain is a consistent set of network configuration information. Classically, the entire set available on a single interface is provided by a single source, such as network administrator, and can therefore be treated as a single provisioning domain. In modern IPv6 networks, multihoming can result in more than one provisioning domain being present on a single link.

To properly handle these multiple-service interfaces, we specify the API not in terms of interfaces, but in terms of provisioning domains. From the perspective of the MIF API, a provisioning domain consists of a link, plus all the configuration information received on that link for that provisioning domain. So for an IPv4 provisioning domain, that would be whatever information is received from the DHCP server. For an IPv6 provisioning domain, the information received through router advertisements would be combined with the information received via DHCPv6.

3.2. MIF API Elements

There are a number of different, essentially independent, pieces of software that need to be connected together in order to fully support a successful MIF communication strategy. These elements are shown in figure 3.1.

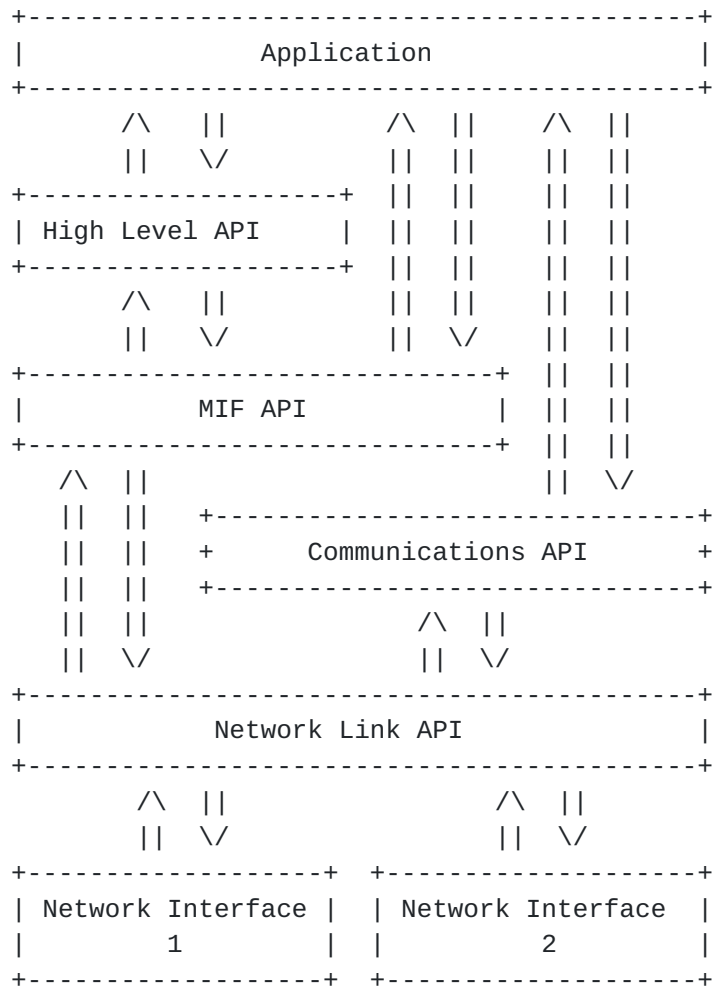

Figure 1: MIF API Elements

3.2.1. Application Element

This is an actual application. Applications fall into a variety of broad categories, including network servers, web browsers, peer-to-peer programs, and so on. Although we are focusing here on the mechanisms required to allow these applications to originate connections to remote nodes, it is worth noting that applications must also be able to receive connections from remote nodes.

3.2.2. High Level API

Applications are generally expected to originate connections using some general-purpose high-level API suited to their particular function. It is likely that different applications may use different high-level APIs to communicate, depending on their particular needs. We do not describe the functioning of such high-level APIs; however,

one such API under current consideration is the Happy Eyeballs for MIF [reference]. These APIs are expected to be able to be implemented using functionality like that described in the MIF API.

3.2.3. MIF API

This is the API being described in this document. Generally speaking, this API is used by higher-level APIs. However, it is permissible for applications to use the MIF API when it is deemed necessary. Currently, several modern web browsers take this approach to establishing network connections, rather than relying on vendor-provided connection mechanisms.

3.2.4. Communications API

Once an application has originated a connection with a remote node using either a high-level API or the MIF API, it must communicate. Similarly, when an application receives a connection from a remote node, it must communicate with that remote node. The communications API is used for this communication. Popular examples of such APIs include the POSIX socket API and a variety of other related APIs.

It is likely that in some instances, implementations of the MIF API will be done as extensions to the Communications API provided by a particular operating system; the functional separation we show here is intended to allow us to illustrate only those features required in a MIF environment, while relying on existing communications APIs to provide the rest.

3.2.5. Network Link API

This is the software that is responsible for actually managing whatever network links are present on a node, whether these are physical links or tunnels. What precisely this functional box contains may vary greatly from device to device. On a typical modern computer workstation, this functionality would almost certainly reside entirely in the system kernel; however, on an embedded device everything from the Application down to the Network Link API could easily be running together on the bare metal as a single program.

The Network Link API can completely be concealed from the Application, so we don't show a connection between them on the functional diagram, and indeed we do not talk about the functionality provided by this API. The reason for showing it on the functional diagram is simply to show that there likely is an API in common between MIF and the Communications API.

3.2.6. MIF API communication model

MIF API requests are made in the form of messages posted to the MIF API, and messages received from it. To accomplish this, several API calls are available. These calls mediate communication between the MIF API and the High Level API, or between the MIF API and the Application. In addition, the CHECK MESSAGE call allows the application to probe for or wait for messages from any of the APIs.

3.2.6.1. POST MESSAGE call

This call causes a message to be posted to the MIF API. The call posts the message, and then returns.

3.2.6.2. CHECK MESSAGE call

This call checks to see if there is a message waiting either from the High Level API, the MIF API, or the Communications API. Ideally it should be able to report the availability of any message or event that the application might anticipate receiving, so that the application can simply block waiting for such an event using this call. The application should be able to do a non-blocking probe, wait for some limited period of time, or wait indefinitely.

An example of a function of this type in existing practice is the POSIX poll() system call.

3.2.6.3. GET MESSAGE call

This call checks to see if there is a message waiting. If there is no message, it returns a status code indicating that there is no message waiting. If there is a message, it returns the message.

3.2.7. MIF Messages

MIF messages always go in one direction or the other: from the subscriber to the MIF API, or to the subscriber from the MIF API. We use the term "subscriber" here to mean either the Application or the High Level API, since either is permitted to communicate with the MIF API.

Messages described here are grouped according to function.

3.2.7.1. Announce Interfaces

This message is sent to the MIF API to ask it to send a message announcing the existence of any interface. When the MIF API receives this message from a subscriber, it iterates across the list of all

known interfaces; for each known interface, it sends an Interface Announcement message to the subscriber.

In addition, the MIF API sets a flag indicating that the subscriber is interested in learning about new interfaces. When the MIF API detects the presence of a new interface, it sends an Interface Announcement message for that interface to the subscriber. This would happen, for instance, when a new tunnel is configured, or when a USB device that is a network interface is discovered by the Network API.

Also, if a network interface goes away, either because the physical network device is disconnected, or because a tunnel is disabled, the MIF API will send a No Interface Announcement message to the subscriber.

3.2.7.2. Stop Announcing Interfaces

This message is sent to the MIF API when a subscriber is no longer interested in receiving announcements about new interfaces. Subsequently, the MIF API will no longer send Interface Announcement or No Interface Announcement messages to the subscriber.

3.2.7.3. Interface Announcement

This message announces the existence of an interface. The announcement includes an interface display name and interface identifier.

3.2.7.4. No Interface Announcement

This message announces that an interface that had been previously announced is no longer present. The announcement includes the interface identifier.

3.2.7.5. Announce Provisioning Domain

This message requests the MIF API to announce the availability of any provisioning domains configured on a particular interface. The interface identifier must be specified.

Upon receipt, the MIF API will iterate across the list of Provisioning Domains present for a particular interface, and will send a Provisioning Domain Announcement for each such Provisioning Domain.

In addition, the MIF API will set a flag indicating that the subscriber wishes to know about new provisioning domains as they

appear. Subsequently, when a new Provisioning Domain appears, the MIF API will send a Provisioning Domain Announcement message to the subscriber.

Finally, if a Provisioning Domain expires or is invalidated, the MIF API will send the subscriber a No Provisioning Domain Announcement message for that Provisioning Domain.

In the event that an interface on which provisioning domains has been announced goes away, a No Provisioning Domain Announcement message will be sent for each provisioning domain that had previously been announced on that interface before the No Interface Announcement message is sent.

Once a No Interface Announcement message has been sent, any subscriber that had subscribed to Provisioning Domain announcements for that interface will be automatically unsubscribed.

3.2.7.6. Stop Announcing Provisioning Domains

This message requests that the MIF API stop sending the subscriber Provisioning Domain Announcement and No Provisioning Domain Announcement messages. The subscriber must indicate the interface for which it no longer wishes to receive Provisioning Domain announcements.

3.2.7.7. Provisioning Domain Announcement

This message is sent by the MIF API to the subscriber to indicate that a new Provisioning Domain has successfully been configured on an interface. The announcement includes the interface identifier and the provisioning domain identifier.

3.2.7.8. No Provisioning Domain Announcement

This message is sent by the MIF API to the subscriber to indicate that an existing, previously announced provisioning domain has expired or otherwise become invalid, and can no longer be used.

3.2.7.9. Announce Configuration Element

This message is sent by the subscriber to request a specific configuration element from a specific provisioning domain. A provisioning domain identifier must be specified.

The MIF API will respond by iterating across the complete list of configuration elements for a provisioning domain, sending a

Configuration Element Announcement message to the subscriber for each one.

Additionally, if any Configuration Elements subsequently complete for a particular provisioning domain, the MIF API will send a Configuration Element Announcement message to the subscriber for each such element. If a Configuration Element becomes invalidated after it has been announced, the MIF API will send a No Configuration Element message.

If a provisioning domain expires or becomes invalid, the MIF API will iterate across the list of remaining configuration elements for that provisioning domain and send a No Configuration Element Announcement message for each such configuration element.

3.2.7.10. Configuration Element Announcement

The Configuration Element Announcement message includes a Provisioning Domain ID and a Configuration Element Type, which can be one of the following: Config Element RA Config Element DHCPv6 Config Element DHCPv4 etc.

3.2.7.11. No Configuration Element Announcement

The No Configuration Element Announcement message indicates that a previously valid configuration element for a provisioning domain is no longer valid. The message includes a provisioning domain identifier and a configuration element type.

3.2.7.12. Stop Announce Configuration Element

The Stop Announce Configuration Element message requests that MIF API stop announce configuration element.

3.2.7.13. Announce Address

This message is sent by the subscriber to request announcements of valid IP addresses for a specific provisioning domain. A provisioning domain identifier must be specified.

The MIF API will respond by iterating across the complete list of configuration elements for a provisioning domain, sending a Address Announcement message to the subscriber.

Additionally, if any new Address is subsequently configured on a particular provisioning domain, the MIF API will send an Address Announcement message to the subscriber for each such element. If an

address becomes invalidated after it has been announced, the MIF API will send a No Address Announcement message.

If a provisioning domain expires or becomes invalid, the MIF API will iterate across the list of remaining configuration elements for that provisioning domain and send a No Address Announcement message for each such address.

3.2.7.14. Address Announcement

The Address Announcement message includes single IPv4 or IPv6 address and a Provisioning Domain identifier, as well as the valid and preferred lifetimes for that IP address (IPv6 only).

3.2.7.15. Stop Announcing Address

The Stop Announcing Address message requests the MIF API to stop announcing address.

3.2.7.16. No Address Announcement

The No Address Announcement message indicates that a previously valid address for a provisioning domain is no longer valid. The message includes a provisioning domain identifier and an IPv4 or IPv6 address.

3.2.7.17. Get Configuration Data

The Get Configuration Data message is sent to the MIF API, and includes a Provisioning Domain ID, a Configuration Element Type, and a Configuration Information Identifier.

Configuration Information Identifiers: DNS Server List etc.

The MIF API searches the configuration database for the specific type of Configuration Element on the specified Provisioning Domain to see if there is any configuration data of the specified type. If so, the MIF API sends a Configuration Data message to the subscriber; otherwise it sends a No Configuration Data message to the subscriber.

3.2.7.18. Translate Name

The Translate Name message is sent to the MIF API. It includes a provisioning domain and a name, which is a UTF8 string naming a network node. The message also includes a Translation Identifier, which the subscriber must ensure is unique across all outstanding name service requests.

The MIF API begins a name resolution process. As results come in from the name resolution process, the MIF API sends Name Translation messages to the subscriber for each such result.

Name resolution can be handled by one or more translations systems such as local host table lookup, Domain Name System, NIS, LLMNR, and is implementation-dependent. **need to think about this

3.2.7.19. Stop Translating Name

This message is sent to the MIF API to indicate that the subscriber is no longer interested in additional results from a particular name translation process. The message includes the Translation Identifier.

3.2.7.20. Name Translation

The MIF API sends a Name Translation message to subscribers whenever results come in from a name translation process being performed on behalf of the subscriber. The Name Translation message includes the Translation ID generated by the subscriber, and an IP address returned by the translation process. If a single translation result contains more than one IP address, or IP addresses of different types, the MIF API sends a single Name Translation message for each such IP address.

3.2.7.21. Connect to Pvd

The Connect to Pvd message is used for the advanced application to select the Pvd. Advanced application can use this message to select a specific Pvd by providing the Pvd identifier as parameter. This is the advanced case that discussed in section 6.3 of [[I-D.ietf-mif-mpvd-arch](#)].

3.2.7.22. Connect to Address

The Connect to Address message contains an IP address, a provisioning domain identifier, and a connection identifier which the subscriber must ensure is unique. The MIF API attempts to initiate a TCP connection to the specified IP address using one or more source addresses that are valid for the specified provisioning domain, according to the source address selection policy for that provisioning domain.

If the connection subsequently succeeds, the MIF API will send a Connected message to the subscriber. If it subsequently fails, the MIF API will send a Not Connected message to the subscriber.

3.2.7.23. Connect to Address From Address

The Connect to Address From Address message contains a source IP address, a destination IP address, a provisioning domain identifier, and a connection identifier which the subscriber must ensure is unique. The MIF API attempts to initiate a TCP connection to the specified IP address using the specified source address.

If the connection subsequently succeeds, the MIF API will send a Connected message to the subscriber. If it subsequently fails, the MIF API will send a Connection Failed message to the subscriber.

3.2.7.24. Connected

The Connected message contains the connection identifier that was provided in a previous Connect to Address or Connect to Address From Address message sent by the subscriber. It also contains an token, suitable for use with the connection API, for communicating with the end node to which the connection was established.

3.2.7.25. Not Connected

The Not Connected message contains the connection identifier that was provided in a previous Connect to Address or Connect to Address From Address message sent by the subscriber. It also contains an indication as to what went wrong with the connection.

3.2.7.26. Application Connectivity Management

The following APIs are used for application connectivity management.

3.2.7.26.1. Application: Wants to connect

This message is sent by the application to the MIF API that indicates the application wants to connect to the network. The purpose of this call is to trigger the MIF API to engage in any work that is required to configure the network. If all interfaces are already operational, this message is a no-op. An application would typically send this message either because it has no provisioning domains on which it can attempt to connect, or because it has failed to connect on any existing provisioning domain.

3.2.7.26.2. Application: Connection is idle

This message is sent by the applicaiton to the MIF API to indicate that the application is not expecting to receive any data or send any data. This is a signal to the MIF API that, for example a radio that consumes a lot of power can be put into a temporary idle state, but

that the application expects to resume communication in the future using the existing connection.

3.2.7.26.3. Application: Connection can be broken

This message is sent by the application to the MIF API to indicate that the application can tolerate the connection being broken. This is a signal that the application could use the connection in the future if it were not broken, but can re-establish the connection if it is broken without any loss of functionality. A MIF API implementation on a power-conservative device might take this as a signal to shut down radios to conserve power.

3.2.7.26.4. Interface is going away

This message is sent by the MIF API to the application to indicate that an interface is going away. This can happen when the interface is still up but the system intends to take it down.

3.2.7.26.5. Interface is going up

This message is sent by the MIF API to the application to indicate that an interface is going up. This can happen when the interface is still down but the system intends to take it up.

3.3. Example Usage

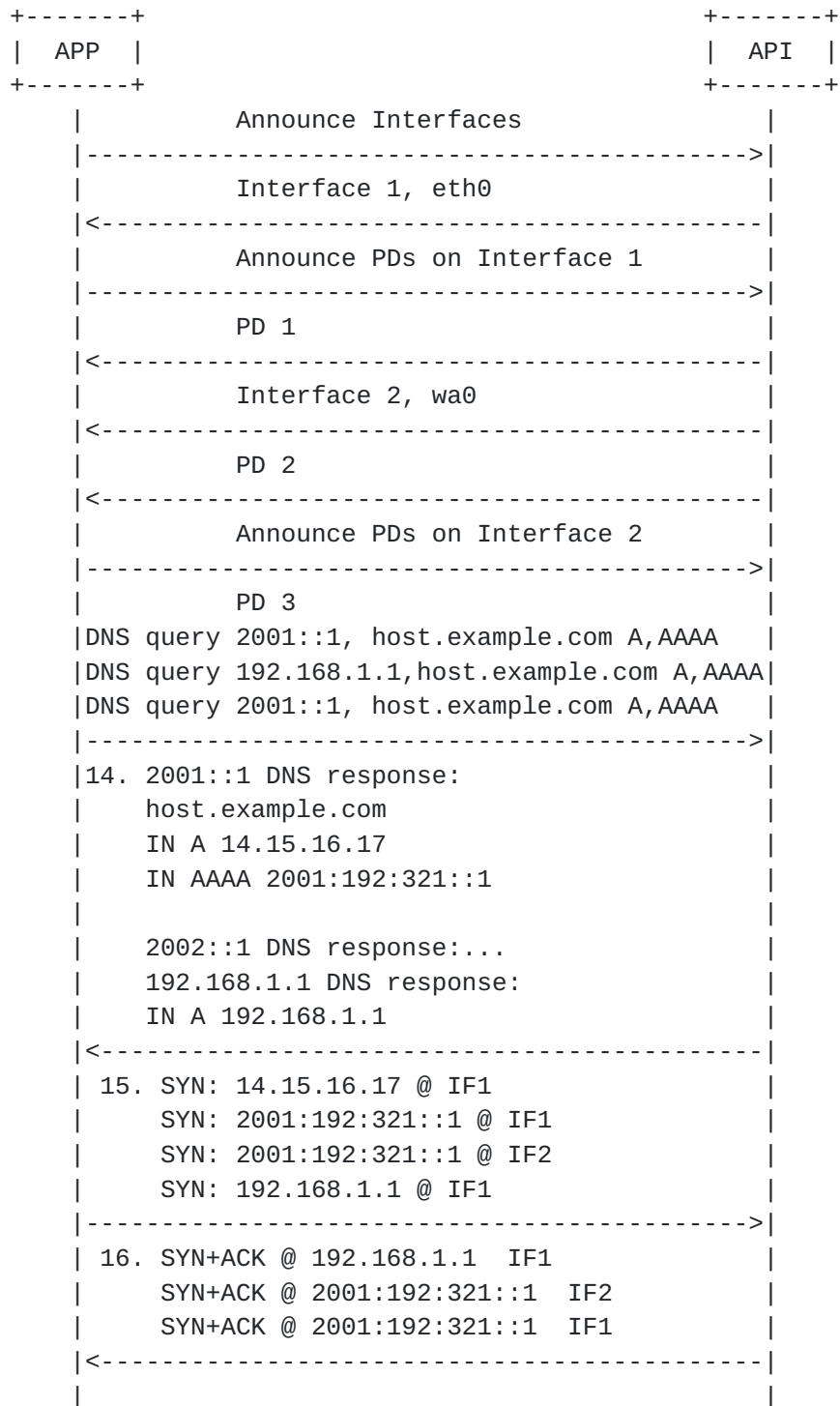

MIF API communication model

As shown in the preceding example, the application first invokes the MIF API to get a list of all the network interfaces in the host. As

soon as each interface has been identified, the application invokes the MIF API to get a list of provisioning domains that are attached to that interface.

The application then invokes the MIF API to look up a name in the context of each provisioning domain. The name lookup may return more than one IP address for each queried host name.

The application then tries to connect to each such IP addresses by sending tcp SYN packet to each destination IP addresses through the provisioning domain on which it received that name. Some of the destination IP addresses may return an ACK packet; others may not.

The application then chooses a connection based on its preferred criteria. For example, the criteria may based on the quality of the link, who answered first, or whether, for example, a TLS authentication succeeds on that connection.

4. Security Considerations

This document specifies an abstract API and will not affect any existing protocols. It does not introduce any new security risk.

5. IANA Considerations

None

6. Acknowledgments

The authors want to thank Teemu Savolainen from Nokia, Dayi Zhao from Bitway, Dave Thaler from Microsoft and others for their useful suggestions and discussions. We would also like to acknowledge Yuri Ismailov's work as the author of the initial version of this document, but was drawn away by other work and let us continue.

7. References

7.1. Normative References

[RFC2119] Bradner, S., "Key words for use in RFCs to Indicate Requirement Levels", [BCP 14](#), [RFC 2119](#), March 1997.

7.2. Informative References

[I-D.ietf-mif-mpvd-arch]
Anipko, D., "Multiple Provisioning Domain Architecture", [draft-ietf-mif-mpvd-arch-00](#) (work in progress), February 2014.

[I-D.scharf-mptcp-api]

Scharf, M. and A. Ford, "MPTCP Application Interface Considerations", [draft-scharf-mptcp-api-02](#) (work in progress), July 2010.

[RFC3493] Gilligan, R., Thomson, S., Bound, J., McCann, J., and W. Stevens, "Basic Socket Interface Extensions for IPv6", [RFC 3493](#), February 2003.

Authors' Addresses

Dapeng Liu
China Mobile
Unit2, 28 Xuanwumenxi Ave, Xuanwu District
Beijing 100053
China

Email: liudapeng@chinamobile.com

Ted Lemon
Nominum
Redwood City
CA 94063
USA

Email: Ted.Lemon@nominum.com

Yuri Ismailov
Ericsson
Stockholm
Sweden
USA

Email: yuri@ismailov.eu

Zhen Cao
China Mobile
Unit2, 28 Xuanwumenxi Ave, Xuanwu District
Beijing 100053
China

Email: caozhen@chinamobile.com

