

Mobile IP Working Group S.
Glass
INTERNET DRAFT Sun
Microsystems
11 January 2000 T.
Hiller
Lucent
Technologies
S.
Jacobs
GTE
Laboratories
C.
Perkins
Nokia Research
Center

Mobile IP Authentication, Authorization, and Accounting Requirements
[draft-ietf-mobileip-aaa-reqs-01.txt](#)

Status of This Memo

This document is a submission by the mobile-ip Working Group of the Internet Engineering Task Force (IETF). Comments should be submitted to the MOBILE-IP@STANDARDS.NORTELNETWORKS.COM mailing list.

Distribution of this memo is unlimited.

This document is an Internet-Draft and is in full conformance with all provisions of [Section 10 of RFC2026](#). Internet-Drafts are working documents of the Internet Engineering Task Force (IETF), its areas, and its working groups. Note that other groups may also distribute working documents as Internet-Drafts.

Internet-Drafts are draft documents valid for a maximum of six months and may be updated, replaced, or obsoleted by other documents at any time. It is inappropriate to use Internet-Drafts as reference material or to cite them other than as "work in progress."

The list of current Internet-Drafts can be accessed at:
<http://www.ietf.org/ietf/1id-abstracts.txt>

The list of Internet-Draft Shadow Directories can be accessed at:
<http://www.ietf.org/shadow.html>.

Abstract

The Mobile IP and AAA working groups are currently looking at defining the requirements for Authentication, Authorization, and Accounting. This document contains the requirements which would have to be supported by a AAA service to aid in providing Mobile IP services.

Glass, Hiller, Jacobs, Perkins
i]

Expires 11 July 2000

[Page

1. Introduction

Clients obtain Internet services by negotiating a point of attachment to a "home domain", generally from an ISP, or other organization from which service requests are made, and fulfilled. With the increasing popularity of mobile devices, a need has been generated to allow users to attach to any domain convenient to their current location. In this way, a client needs access to resources being provided by an administrative domain different than their home domain (called a "foreign domain"). The need for service from a foreign domain requires, in many models, Authorization, which leads directly to Authentication, and of course Accounting (whence, "AAA"). There is some argument which of these leads to, or is derived from the others, but there is common agreement that the three AAA functions are closely interdependent.

An agent in a foreign domain, being called on to provide access to a resource by a mobile user, is likely to request or require the client to provide credentials which can be authenticated before access to resources are permitted. The resource may be as simple as a conduit to the Internet, or may be as complex as access to specific private resources within the foreign domain. Credentials can be exchanged in many different ways, all of which are beyond the scope of this document. Once authenticated, the mobile user may be authorized to access services within the foreign domain. An accounting of the actual resources may then be assembled.

Mobile IP is a technology that allows a network node ("mobile node") to migrate from its "home" network to other networks, either within the same administrative domain, or to other administrative domains. The possibility of movement between domains which require AAA services has created an immediate demand to design and specify AAA protocols. Once available, the AAA protocols and infrastructure will provide the economic incentive for a wide-ranging deployment of Mobile IP. This document will identify, describe, and discuss the functional and performance requirements that Mobile IP places on AAA protocols.

The formal description of Mobile IP can be found in [[13](#), [12](#), [14](#), [17](#)].

Glass, Hiller, Jacobs, Perkins
1]

Expires 11 July 2000

[Page

In this document, we have attempted to exhibit requirements in a progressive fashion. After showing the basic AAA model for Mobile IP, we derive requirements as follows:

- requirements based on the general model
- requirements based on providing IP service for mobile nodes
- requirements derived from specific Mobile IP protocol needs

Then, we exhibit some related AAA models and describe requirements derived from the related models.

2. Terminology

This document frequently uses the following terms in addition to those defined in [RFC 2002](#) [13]:

Accounting The act of collecting information on resource usage for the purpose of trend analysis, auditing, billing, or cost allocation.

Administrative Domain

An intranet, or a collection of networks, computers, and databases under a common administration. Computer entities operating in a common administration may be assumed to share administratively created security associations.

Attendant A node designed to provide the service interface between a client and the local domain.

Authentication

The act of verifying a claimed identity, in the form of a pre-existing label from a mutually known name space, as the originator of a message (message authentication) or as the end-point of a channel (entity authentication).

Authorization

The act of determining if a particular right, such as access to some resource, can be granted to the presenter of a particular credential.

Billing The act of preparing an invoice.

Broker An intermediary agent, trusted by two other AAA services servers, able to obtain and provide security from those AAA servers. For instance, a broker may

Glass, Hiller, Jacobs, Perkins
2]

Expires 11 July 2000

[Page

that obtain and provide authorizations, or assurances
credentials are valid.

Client A node wishing to obtain service from an attendant
within an administrative domain.

Foreign Domain

An administrative domain, visited by a Mobile IP
client, and containing the AAA infrastructure needed
to carry out the necessary operations enabling
Mobile IP registrations. From the point of view of
the foreign agent, the foreign domain is the local
domain.

Inter-domain Accounting

Inter-domain accounting is the collection of
information on resource usage of an entity with
an administrative domain, for use within another
administrative domain. In inter-domain accounting,
accounting packets and session records will
typically cross administrative boundaries.

Intra-domain Accounting

Intra-domain accounting is the collection of
information on resource within an administrative
domain, for use within that domain. In intra-domain
accounting, accounting packets and session records
typically do not cross administrative boundaries.

Local Domain

An administrative domain containing the AAA
infrastructure of immediate interest to a Mobile IP
client when it is away from home.

Real-time Accounting

Real-time accounting involves the processing of
information on resource usage within a defined time
window. Time constraints are typically imposed in
order to limit financial risk.

Session record

A session record represents a summary of the
resource consumption of a user over the entire session.
Accounting gateways creating the session record may
do so by processing interim accounting events.

In this document, the key words "MAY", "MUST", "MUST NOT",
"optional",
"recommended", "SHOULD", and "SHOULD NOT", are to be interpreted as

described in [\[4\]](#).

Glass, Hiller, Jacobs, Perkins
3]

Expires 11 July 2000

[Page

3. Basic Model

In this section, we attempt to capture the main features of a basic model for operation of AAA servers that seems to have good support within the Mobile IP working group. Within the Internet, a client belonging to one administrative domain (called the home domain) often needs to use resources provided by another administrative domain (called the foreign domain). An agent in the foreign domain that attends to the client's request (call the agent the "attendant") is likely to require that the client provide some credentials that can be authenticated before access to the resources is permitted.

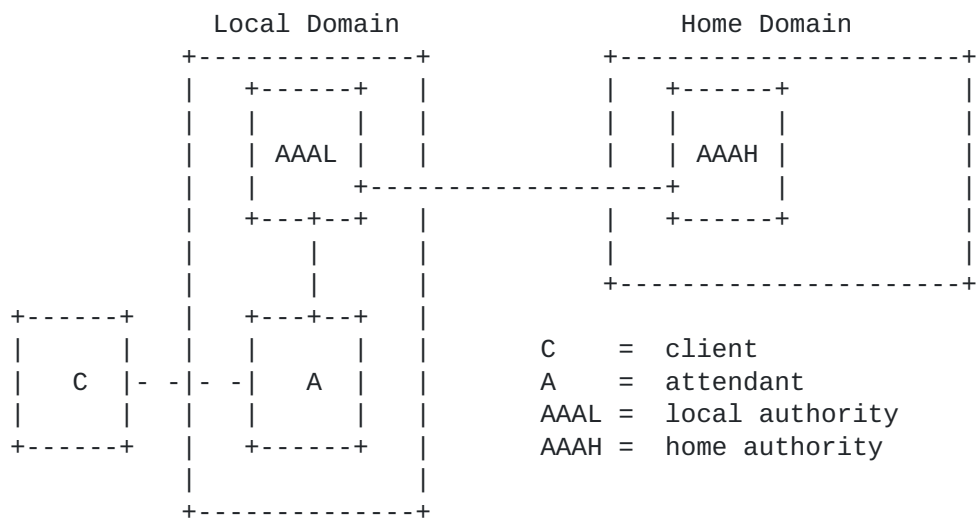

Figure 1: AAA Servers in Home and Local Domains

The attendant often does not have direct access to the data needed to complete the transaction. Instead, the attendant is expected to consult an authority (typically in the same foreign domain) in order to request proof that the client has acceptable credentials. Since the attendant and the local authority are part of the same administrative domain, they are expected to have security relationships that enable them to securely transact information locally.

The local authority (AAAL) itself may not have enough information stored locally to carry out the verification for the credentials of the client. In contrast to the attendant, however, the AAAL is expected to be configured with enough information to negotiate the verification of client credentials with external authorities. The local and the external authorities should be configured with

Glass, Hiller, Jacobs, Perkins
4]

Expires 11 July 2000

[Page

sufficient security relationships and access controls so that they, possibly without the need for any other AAA agents, can negotiate the authorization that may enable the client to have access to the requested resources. In many typical cases, the authorization depends only upon secure authentication of the client's credentials.

Once the authorization has been obtained by the local authority, and the authority has notified the attendant about the successful negotiation, the attendant can provide the requested resources to the client.

In the picture, there might be many attendants for each AAAL, and there might be many clients from many different Home Domains. Each Home Domain provides a AAAH that can check credentials originating from clients administered by that Home Domain.

There is a security model implicit in the above figure, and it is crucial to identify the specific security associations assumed in the security model.

First, it is natural to assume that the client has a security association with the AAAH, since that is roughly what it means for the client to belong to the home domain.

Second, from the model illustrated in figure 1 it is clear that AAAL and AAAH have to share a security association, because otherwise they could not rely on the authentication results, authorizations, nor even the accounting data which might be transacted between them. Requiring such bilateral security relationships is, however, in the end not scalable; the AAA framework MUST provide for more scalable mechanisms, as suggested below in [section 6](#).

Finally, in the figure, it is clear that the attendant can naturally share a security association with the AAAL. This is necessary in order for the model to work because the attendant has to be know that it is permissible to allocate the local resources to the client.

As an example in today's Internet, we can cite the deployment of RADIUS [16] to allow mobile computer clients to have access to the Internet by way of a local ISP. The ISP wants to make sure that the mobile client can pay for the connection. Once the client has provided credentials (e.g., identification, unique data, and an unforgeable signature), the ISP checks with the client's home authority to verify the signature, and to obtain assurance that the client will pay for the connection. Here, the attendant function can be carried out by the NAS, and the local and home authorities can use RADIUS servers. Credentials allowing authorization at one attendant

SHOULD be unusable in any future negotiations at the same or any other attendant.

Glass, Hiller, Jacobs, Perkins
5]

Expires 11 July 2000

[Page

From the description and example above, we can identify several requirements.

- Each local attendant has to have a security relationship with the local AAA server (AAAL)
- The local authority has to share, or dynamically establish, security relationships with external authorities that are able to check client credentials
- The attendant has to keep state for pending client requests while the local authority contacts the appropriate external authority
- Since the mobile node may not necessarily initiate network connectivity from within its home domain, it **MUST** be able to provide complete, yet unforgeable credentials without ever having been in touch with its home domain.
- Since the mobile node's credentials have to remain unforgeable, intervening nodes (e.g., neither the attendant or the local authority (AAAL) or any other intermediate nodes) **MUST NOT** be able to learn any (secret) information which may enable them to reconstruct and reuse the credentials.

From this last requirement, we can see the reasons for the natural requirement that the client has to share, or dynamically establish, a security relationship with the external authority in the Home Domain. Otherwise, it is technically infeasible (given the implied network topology) for the client to produce unforgeable signatures that can be checked by the AAAH. Figure 2 illustrates the natural security associations we understand from our proposed model. Note that, according to the discussion in [section 6](#), there may, by mutual agreement between AAAL and AAAH, be a third party inserted between AAAL and AAAH to help them arbitrate secure transactions in a more scalable fashion.

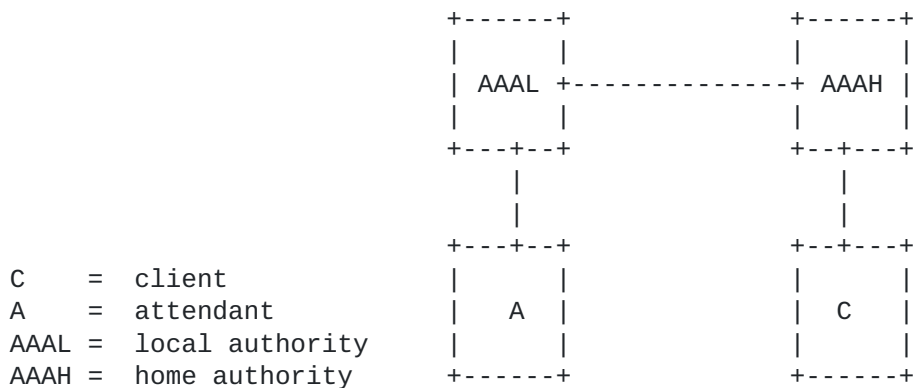

Figure 2: Security Associations

Glass, Hiller, Jacobs, Perkins
6]

Expires 11 July 2000

[Page

In addition to the requirements listed above, we specify the following requirements which derive from operational experience with today's roaming protocols.

- There are scenarios in which an attendant will have to manage requests for many clients at the same time.
- The attendant **MUST** protect against replay attacks.
- The attendant equipment should be as inexpensive as possible, since it will be replicated as many times as possible to handle as many clients as possible in the foreign domain.
- Attendants **SHOULD** be configured to obtain authorization, from a trusted local AAA server (AAAL) for Quality of Service requirements placed by the client.

Nodes in two separate administrative domains (for instance, AAAH and AAAL) often must take additional steps to verify the identity of their communication partners, or alternatively to guarantee the privacy of the data making up the communication. While these considerations lead to important security requirements, as mentioned above in the context of security between servers, we consider the exact choice of security associations between the AAA servers to be beyond the scope of this document. The choices are unlikely even to depend upon any specific features of the general model illustrated in figure 1. On the other hand, the security associations needed between Mobile IP entities will be of central importance in the design of a suitable AAA infrastructure for Mobile IP. The general model shown above is generally compatible with the needs of Mobile IP. However, some basic changes are needed in the security model of Mobile IP, as detailed in [section 5](#).

Lastly, recent discussion in the mobile-ip working group has indicated that the attendant **MUST** be able to terminate service to the client based on policy determination by either AAAH or AAAL server.

3.1. AAA Protocol Roaming Requirements

In this section we will detail additional requirements based on issues discovered through operational experience of existing roaming RADIUS networks. The AAA protocol **MUST** satisfy these requirements in order for providers to offer a robust service. These requirements

Glass, Hiller, Jacobs, Perkins
7]

Expires 11 July 2000

[Page

have been identified by TR45.6 as part of their involvement with the Mobile IP working group.

- Support a reliable AAA transport mechanism.
 - * There must be an effective hop-by-hop retransmission and failover mechanism so that reliability does not solely depend on end-to-end retransmission
 - * This transport mechanism will be able indicate to an AAA application that a message was delivered to the next peer AAA application or that a time out occurred.
 - * Retransmission is controlled by the reliable AAA transport mechanism, and not by lower layer protocols such as TCP.
 - * Even if the AAA message is to be forwarded, or the message's options or semantics do not conform with the AAA protocol, the transport mechanism will acknowledge that the peer received the AAA message.
 - * Acknowledgements SHOULD be allowed to be piggybacked in AAA messages
 - * AAA responses have to be delivered in a timely fashion so that Mobile IP does not timeout and retransmit
- Transport a digital certificate in an AAA message, in order to minimize the number of round trips associated with AAA transactions. Note: This requirement applies to AAA applications and not mobile stations. The certificates could be used by foreign and home agents to establish an IPsec security association to secure the mobile node's tunneled data. In this case, the AAA infrastructure could assist by obtaining the revocation status of such a certificate (either by performing online checks or otherwise validating the certificate) so that home and foreign agents could avoid a costly online certificate status check.
- Provide message integrity and identity authentication on a per hop (AAA node) basis.
- Support replay protection and optional non-repudiation capabilities for all authorization and accounting messages. The AAA protocol must provide the capability for accounting messages to be matched with prior authorization messages.
- Support accounting via both bilateral arrangements and via broker AAA servers providing accounting clearinghouse and reconciliation between serving and home networks. There is an explicit agreement that if the private network or home ISP authenticates the mobile station requesting service, then the private network or home ISP network also agrees to reconcile charges with the home service provider or broker. Real time accounting must be supported.

Glass, Hiller, Jacobs, Perkins
8]

Expires 11 July 2000

[Page

4. Requirements related to basic IP connectivity

The requirements listed in the previous section pertain to the relationships between the functional units, and don't depend on the underlying network addressing. On the other hand, many nodes (mobile or merely portable) are programmed to receive some IP-specific resources during the initialization phase of their attempt to connect to the Internet.

We place the following additional requirements on the AAA services in order to satisfy such clients.

- Either AAA server MUST be able to obtain, or to coordinate the allocation of, a suitable IP address for the customer, upon request by the customer.
- AAA servers MUST be able to identify the client by some means other than its IP address.

Policy in the home domain may dictate that the home agent instead of the AAAH manages the allocation of an IP address for the mobile node. AAA servers MUST be able to coordinate the allocation of an IP address for the mobile node at least in this way.

AAA servers today identify clients by using the Network Access Identifier (NAI) [1]. A mobile node can identify itself by including the NAI along with the Mobile IP Registration Request [6]. The NAI is of the form "user@realm"; it is unique and well suited for use in the AAA model illustrated in figure 1. Using a NAI (e.g., "user@realm") allows AAAL to easily determine the home domain (e.g., "realm") for the client. Both the AAAL and the AAAH can use the NAI to keep records indexed by the client's specific identity.

5. AAA for Mobile IP

Clients using Mobile IP require specific features from the AAA services, in addition to the requirements already mentioned in connection with the basic AAA functionality and what is needed for IP connectivity. To understand the application of the general model for Mobile IP, we consider the mobile node (MN) to be the client in figure 1, and the attendant to be the foreign agent (FA). If a situation arises that there is no foreign agent present, e.g. in the case of an IPv4 mobile node with a co-located care of address or an IPv6 mobile node, the equivalent attendant functionality is to be provided by the address allocation entity, e.g. a DHCP server. Such

an attendant functionality is outside the scope of this document. The home agent, while important to Mobile IP, is allowed to play a role during the initial registration that is subordinate to the role played by the AAAH. For application to Mobile IP, we modify

the general model (as illustrated in figure 3). After the initial registration, the mobile node is authorized to continue using Mobile IP at the foreign domain without requiring further involvement by the AAA servers. Thus, the initial registration will probably take longer than subsequent Mobile IP registrations.

In order to reduce this extra time overhead as much as possible, it is important to reduce the time taken for communications between the AAA servers. A major component of this communications latency is the time taken to traverse the wide-area Internet that is likely to separate the AAAL and the AAAH. This leads to a further strong motivation for integration of the AAA functions themselves, as well as integration of AAA functions with the initial Mobile IP registration. In order to reduce the number of messages that traverse the network for initial registration of a Mobile Node, the AAA functions in the visited network (AAAL) and the home network (AAAH) need to interface with the foreign agent and the home agent to handle the registration message. Latency would be reduced as a result of initial registration being handled in conjunction with AAA and the mobile IP mobility agents. Subsequent registrations, however, would be handled according to [RFC 2002 \[13\]](#).

The AAA home domain and the HA home domain of the mobile node need not be part of the same administrative domain. Such an situation can occur if the home address of the mobile node is provided by one domain, e.g. an ISP that the mobile user uses while at home, and the

authorization and accounting by another (specialized) domain, e.g. a

credit card company. The foreign agent sends only the authentication information of the mobile node to the AAAL, which interfaces to the AAAH. After a successful authorization of the mobile node, the foreign agent is able to continue with the mobile IP registration procedure. Such a scheme introduces more delay if the access to the AAA functionality and the mobile IP protocol is sequentialized. Subsequent registrations would be handled according to [RFC2002 \[13\]](#) without further interaction with the AAA. Whether to combine or separate the Mobile IP protocol data with/from the AAA messages is ultimately a policy decision. A separation of the Mobile IP protocol

data and the AAA messages can be successfully accomplished only if the IP address of the mobile node's home agent is provided to the foreign agent performing the attendant function.

All needed AAA and Mobile IP functions SHOULD be processed during a single Internet traversal. This MUST be done without requiring AAA servers to process protocol messages sent to Mobile IP agents. The AAA servers MUST identify the Mobile IP agents and security associations necessary to process the Mobile IP registration, pass the necessary registration data to those Mobile IP agents, and remain uninvolved in the routing and authentication processing steps

particular to Mobile IP registration.

Glass, Hiller, Jacobs, Perkins
10]

Expires 11 July 2000

[Page

For Mobile IP, the AAAL and the AAAH servers have the following additional general tasks:

- enable authentication for Mobile IP registration
- authorize the mobile node (once its identity has been established) to use at least the set of resources for minimal Mobile IP functionality, plus potentially other services requested by the mobile node
- initiate accounting for service utilization
- use AAA protocol extensions specifically for including Mobile IP registration messages as part of the initial registration sequence to be handled by the AAA servers.

These tasks, and the resulting more specific tasks to be listed later in this section, are beneficially handled and expedited by the AAA servers shown in figure 1 because the tasks often happen together, and task processing needs access to the same data at the same time.

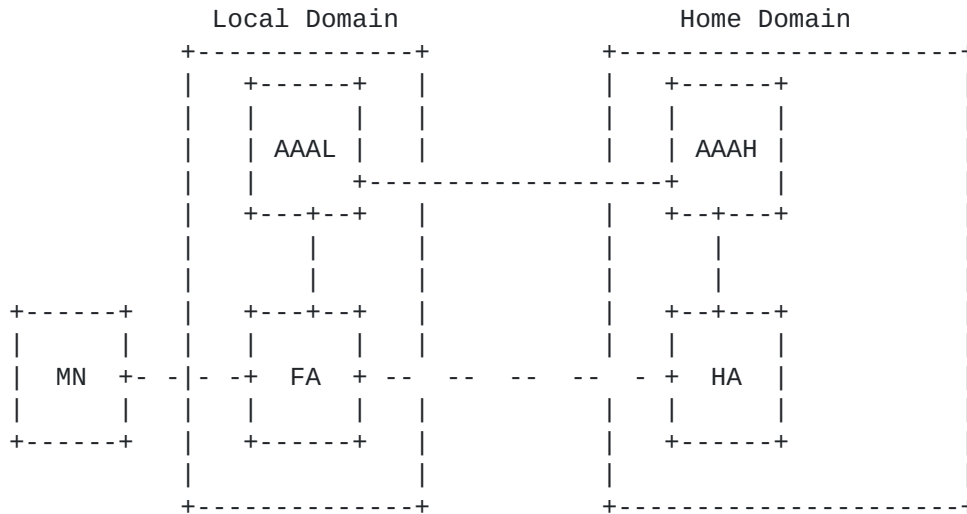

Figure 3: AAA Servers with Mobile IP agents

In the model in figure 1, the initial AAA transactions are handled without needing the home agent, but Mobile IP requires every registration to be handled between the home agent (HA) and the foreign agent (FA), as shown by the sparse dashed (lower) line in figure 3. This means that during the initial registration, something has to happen that enables the home agent and foreign agent to perform subsequent Mobile IP registrations. After the initial registration, the AAAH and AAAL in figure 3 would not be needed,

Glass, Hiller, Jacobs, Perkins
11]

Expires 11 July 2000

[Page

and subsequent Mobile IP registrations would only follow the lower control path between the foreign agent and the home agent.

Any Mobile IP data that is sent by FA through the AAAL to AAAH MUST be considered opaque to the AAA servers. Authorization data needed by the AAA servers then MUST be delivered to them by the foreign agent from the data supplied by the mobile node. The foreign agent becomes a translation agent between the Mobile IP registration protocol and AAA.

As mentioned in [section 3](#), nodes in two separate administrative domains often must take additional steps to guarantee their security and privacy. In today's Internet, such security measures may be provided by using several different algorithms. Some algorithms rely on the existence of a public-key infrastructure [8]; others rely on distribution of symmetric keys to the communicating nodes [9]. AAA servers SHOULD be able to verify credentials using either style in their interactions with Mobile IP entities.

In order to enable subsequent registrations, the AAA servers MUST be able to perform some key distribution during the initial Mobile IP registration process from any particular administrative domain.

Glass, Hiller, Jacobs, Perkins
12]

Expires 11 July 2000

[Page

This key distribution MUST be able to provide the following security functions:

- identify or create a security association between MN and home agent (HA); this is required for the MN to produce the authentication data for the MN--HA authentication extension, which is mandatory on Mobile IP registrations.
- identify or create a security association between mobile node

and

foreign agent, for use with subsequent registrations at the same foreign agent, so that the foreign agent can continue to obtain assurance that the same mobile node has requested the continued authorization for Mobile IP services.

- identify or create a security association between home agent and foreign agent, for use with subsequent registrations at the same foreign agent, so that the foreign agent can continue to obtain assurance that the same home agent has continued the authorization for Mobile IP services for the mobile node.
- participate in the distribution of the security association (and Security Parameter Index, or SPI) to the Mobile IP entities
- The AAA server MUST also be able to validate certificates provided by the mobile node and provide reliable indication to the foreign agent.
- The AAA SHOULD accept an indication from the foreign agent

about

the acceptable lifetime for its security associations with the mobile node and/or the mobile node's home agent. This lifetime for those security associations SHOULD be an integer multiple of registration lifetime offered by the foreign agent to the mobile node.

- The AAA servers SHOULD be able to condition their acceptance of a Mobile IP registration authorization depending upon whether the registration requires broadcast or multicast service to the mobile node tunneled through the foreign agent.
- In addition, reverse tunneling may also be a necessary requirement for mobile node connectivity. Therefore, AAA servers SHOULD also be able to condition their acceptance of Mobile IP registration authorization depending upon whether the registration requires reverse tunnelling support to the home domain through the foreign agent.

The lifetime of any security associations distributed by the AAA server for use with Mobile IP SHOULD be great enough to avoid too-frequent initiation of the AAA key distribution, since each invocation of this process is likely to cause lengthy delays between registrations [5]. Registration delays in Mobile IP cause dropped packets and noticeable disruptions in service. Note that any key distributed by AAAH to the foreign agent and home agent MAY be used to initiate Internet Key Exchange (IKE) [7].

Glass, Hiller, Jacobs, Perkins
13]

Expires 11 July 2000

[Page

Note further that the mobile node and home agent may well have a security association established that does not depend upon any action by the AAAH.

5.1. Mobile IP with Dynamic IP Addresses

According to [section 4](#), many people would like their mobile nodes to be identified by their NAI, and to obtain a dynamically allocated home address for use in the foreign domain. These people may often be unconcerned with details about how their computers implement Mobile IP, and indeed may not have any knowledge of their home agent or any security association except that between themselves and the AAAH (see figure 2. In this case the Mobile IP registration data has to be carried along with the AAA messages. The AAA home domain and the HA home domain have to be part of the same administrative domain.

Mobile IP requires the home address assigned to the mobile node belong to the same subnet as the Home Agent providing service to the mobile node. For effective use of IP home addresses, the home AAA (AAAH) SHOULD be able to select a home agent for use with the newly allocated home address. In many cases, the mobile node will already know the address of its home agent, even if the mobile node does not already have an existing home address. Therefore, the home AAA (AAAH) MUST be able to coordinate the allocation of a home address with a home agent that might be designated by the mobile node.

Allocating a home address and a home agent for the mobile would provide a further simplification in the configuration needs for the client's mobile node. Currently, in the Proposed Standard Mobile IP specification [[13](#)] a mobile node has to be configured with a home address and the address of a home agent, as well as with a security association with that home agent. In contrast, the proposed AAA features would only require the mobile node to be configured with its NAI and a secure shared secret for use by the AAAH. The mobile node's home address, the address of its home agent, the security association between the mobile node and the home agent, and even the identity (DNS name or IP address) of the AAAH can all be dynamically determined as part of Mobile IP initial registration with the mobility agent in the foreign domain (i.e., a foreign agent with AAA interface features). Nevertheless, the mobile node may choose to include the MN-HA security extension as well as AAA credentials, and the proposed Mobile IP and AAA server model MUST work when both are present.

The reason for all this simplification is that the NAI encodes the client's identity as well as the name of the client's home domain; this follows existing industry practice for the way NAIs are used today (see [section 4](#)). The home domain name is then available for

Glass, Hiller, Jacobs, Perkins
14]

Expires 11 July 2000

[Page

use by the local AAA (AAAL) to locate the home AAA serving the client's home domain. In the general model, the AAAL would also have

to identify the appropriate security association for use with that AAAH. [Section 6](#) discusses a way to reduce the number of security associations that have to be maintained between pairs of AAA servers such as the AAAL and AAAH just described.

5.2. Firewalls and AAA

Mobile IP has encountered some deployment difficulties related to firewall traversal; see for instance [\[11\]](#). Since the firewall and AAA server can be part of the same administrative domain, we propose that the AAA server SHOULD be able to issue control messages and keys

to the firewall at the boundary of its administrative domain that will configure the firewall to be permeable to Mobile IP registration and data traffic from the mobile node.

5.3. Mobile IP with Local Home Agents

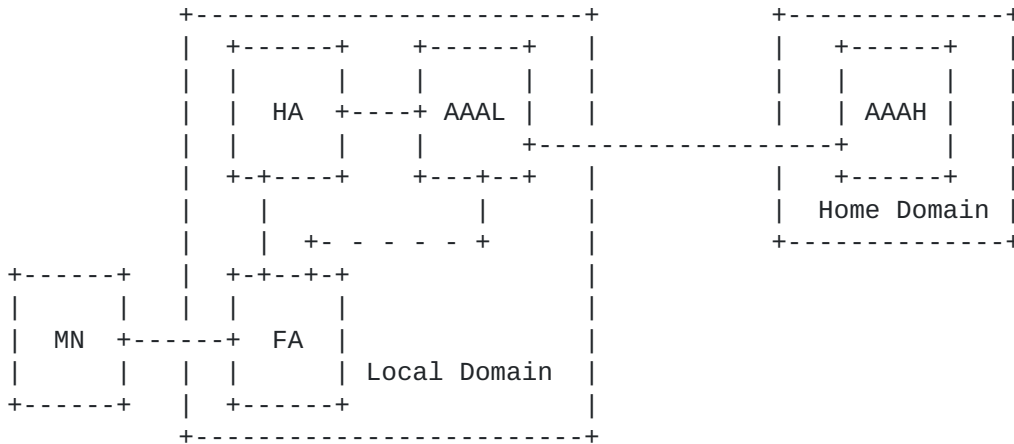

Figure 4: Home Agent Allocated by AAAL

In some Mobile IP models, mobile nodes boot on subnets which are technically foreign subnets, but the services they need are local, and hence communication with the home subnet as if they were residing

on the home is not necessary. As long as the mobile node can get an address routable from within the current domain (be it publicly, or privately addressed) it can use mobile IP to roam around that domain,

calling the subnet on which it booted its temporary home. This

Glass, Hiller, Jacobs, Perkins
15]

Expires 11 July 2000

[Page

address is likely to be dynamically allocated upon request by the mobile node.

In such situations, when the client is willing to use a dynamically allocated IP address and does not have any preference for the location of the home network (either geographical or topological), the local AAA server (AAAL) may be able to offer this additional allocation service to the client. Then, the home agent will be located in the local domain, which is likely to be offer smaller delays for new Mobile IP registrations.

In figure 4, AAAL has received a request from the mobile node to allocate a home agent in the local domain. The new home agent receives keys from AAAL to enable future Mobile IP registrations. From the picture, it is evident that such a configuration avoids problems with firewall protection at the domain boundaries, such as were described briefly in [section 5.2](#). On the other hand, this configuration makes it difficult for the mobile node to receive data from any communications partners in the mobile node's home administrative domain. Note that, in this model, the mobile node's home address is affiliated with the foreign domain for routing purposes. Thus, any dynamic update to DNS, to associate the mobile node's home FQDN (Fully Qualified Domain Name [[10](#)]) with its new IP address, will require insertion of a foreign IP address into the home DNS server database.

5.4. Mobile IP with Local Payments

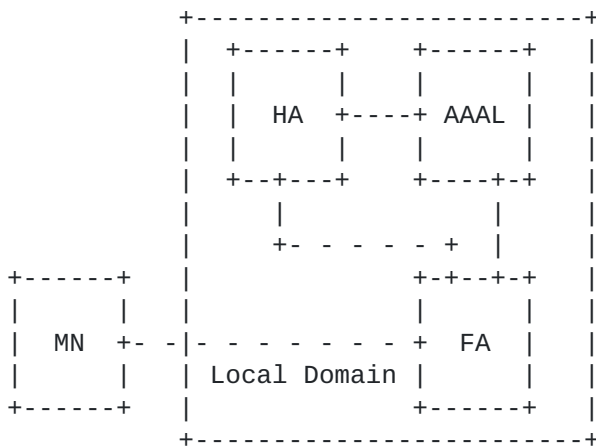

Figure 5: Local Payment for Local Mobile IP services

Glass, Hiller, Jacobs, Perkins
16]

Expires 11 July 2000

[Page

Since the AAAL is expected to be enabled to allocate a local home agent upon demand, we can make a further simplification. In cases where the AAAL can manage any necessary authorization function locally (e.g., if the client pays with cash or a credit card), then there is no need for an AAA protocol or infrastructure to interact with the AAAH. The resulting simple configuration is illustrated in figure 5.

In this simplified model, we may consider that the role of the AAAH is taken over either by a national government (in the case of a cash payment), or by a card authorization service if payment is by credit card, or some such authority acceptable to all parties.

Then,

the AAAL expects those external authorities to guarantee the value represented by the client's payment credentials (cash or credit). There are likely to be other cases where clients are granted access to local resources, or access to the Internet, without any charges

at

all. Such configurations may be found in airports and other common areas where business clients are likely to spend time. The service provider may find sufficient reward in the goodwill of the clients, or from advertisements displayed on Internet portals that are to be used by the clients. In such situations, the AAAL SHOULD still allocate a home agent, appropriate keys, and the mobile node's home address.

5.5. Fast Handover

Since the movement from coverage area to coverage area may be frequent in Mobile IP networks, it is imperative that the latency involved in the handoff process be minimized. See, for instance,

the

Route Optimization draft [15] for one way to do this using Binding Updates. When the mobile node enters a new visited subnet, it would be desirable for it to provide the previous foreign agent's NAI. The new FA can use this information to either contact the previous FA to retrieve the KDC session key information, or it can attempt to retrieve the keys from the AAAL. If the AAAL cannot provide the necessary keying information, the request will have to be sent to

the

mobile node's AAAH to retrieve new keying information. After

initial

authorization, further authorizations SHOULD be done locally within the Local Domain.

6. Broker Model

The picture in Figure 1 shows a configuration in which the local and the home authority have to share trust. Depending on the security model used, this configuration can cause a quadratic growth in the

number of trust relationships, as the number of AAA authorities (AAAL and AAAH) increases. This has been identified as a problem

Glass,Hiller,Jacobs,Perkins
17]

Expires 11 July 2000

[Page

by the roamops working group [3], and any AAA proposal MUST solve this problem. Using brokers solves many of the scalability problems associated with requiring direct business/roaming relationships between every two administrative domains. In order to provide scalable networks in highly diverse service provider networks in which there are many domains (e.g. many service providers and large numbers of private networks), multiple layers of brokers MUST be supported for both of the broker models described.

Integrity or privacy of information between the home and serving domains may be achieved by either hop-by-hop security associations or end-to-end security associations established with the help of the broker infrastructure. A broker may play the role of a proxy between two administrative domains which have security associations with the broker, and relay AAA messages back and forth securely.

Alternatively, a broker may also enable the two domains with which it has associations, but the domains themselves do not have a direct association, in establishing a security association, thereby bypassing the broker for carrying the messages between the domains. This may be established by virtue of having the broker relay a shared secret key to both the domains that are trying to establish secure communication and then have the domains use the keys supplied by the broker in setting up a security association.

Assuming that AAAB accepts responsibility for payment to the serving domain on behalf of the home domain, the serving domain is assured of receiving payments for services offered. However, the redirection broker will usually require a copy of authorization messages from the home domain and accounting messages from the serving domain, in order for the broker to determine if it is willing to accept responsibility for the services being authorized and utilized. If the broker does not accept such responsibility for any reason, then it must be able to terminate service to a mobile node in the serving network. In the event that multiple brokers are involved, in most situations all brokers must be so copied. This may represent an additional burden on foreign agents and AAALs.

Though this mechanism may reduce latency in the transit of messages between the domains after the broker has completed its involvement, there may be many more messages involved as a result of additional copies of authorization and accounting messages to the brokers involved. There may also be additional latency for initial access to the network, especially when a new security association needs to be created between AAAL and AAAH (for example, from the use of ISAKMP).

These delays may become important factors for latency- critical applications.

Glass, Hiller, Jacobs, Perkins
18]

Expires 11 July 2000

[Page

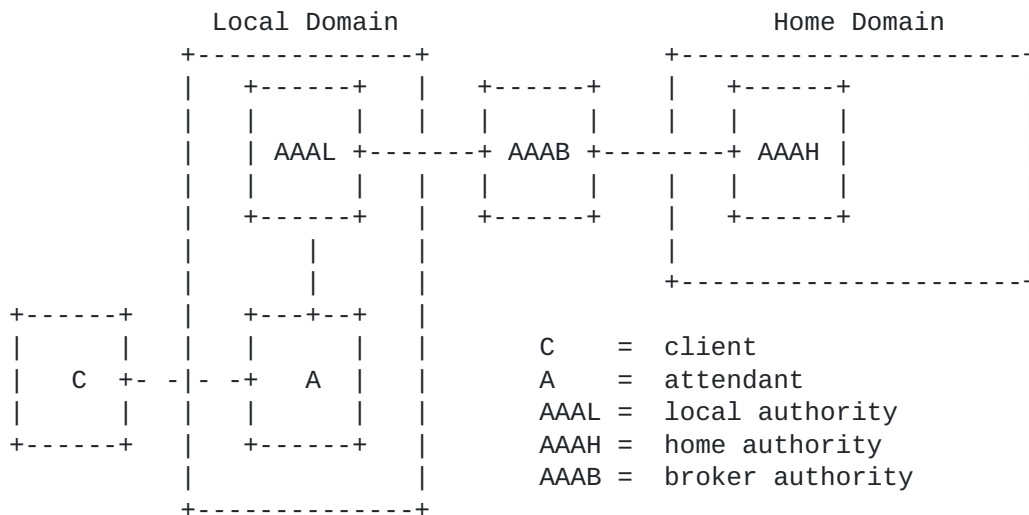

Figure 6: AAA Servers Using a Broker

The AAAB in figure 6 is the broker's authority server. The broker acts as a settlement agent, providing security and a central point of contact for many service providers and enterprises.

The AAAB enables the local and home domains to cooperate without requiring each of the networks to have a direct business or security relationship with all the other networks. Thus, brokers offer the needed scalability for managing trust relationships between otherwise independent network domains. Use of the broker does not preclude managing separate trust relationships between domains, but it does offer an alternative to doing so. Just as with the AAAH and AAAL (see [section 5](#)), data specific to Mobile IP control messages MUST NOT be processed by the AAAB. Any credentials or accounting data to be processed by the AAAB must be present in AAA message units, not extracted from Mobile IP protocol extensions.

The following requirements come mostly from [2], which discusses use of brokers in the particular case of authorization for roaming dial-up users.

- allowing management of trust with external domains by way of brokered AAA.
- accounting reliability. Accounting data that traverses the Internet may suffer substantial packet loss. Since accounting packets may traverse one or more intermediate authorization points (e.g., brokers), retransmission is needed from intermediate points to avoid long end-to-end delays.

Glass, Hiller, Jacobs, Perkins
19]

Expires 11 July 2000

[Page

- End to End security. The Local Domain and Home Domain must be able to verify signatures within the message, even though the message is passed through an intermediate authority server.
- Since the AAAH in the home domain MAY be sending sensitive information, such as registration keys, the broker MUST be able to pass encrypted data between the AAA servers.

The need for End-to-End security results from the following attacks which were identified when brokered operation uses RADIUS [16] (see [2] for more information on the individual attacks):

- + Message editing
- + Attribute editing
- + Theft of shared secrets
- + Theft and modification of accounting data
- + Replay attacks
- + Connection hijacking
- + Fraudulent accounting

These are serious problems which cannot be allowed to persist in any acceptable AAA protocol and infrastructure.

7. Security Considerations

This is a requirements draft for AAA based on Mobile IP. Because AAA is security driven, most of this document addresses the security considerations AAA MUST make on behalf of Mobile IP. As with any security proposal, adding more entities that interact using security protocols creates new administrative requirements for maintaining the appropriate security associations between the entities. In the case of the AAA services proposed however, these administrative requirements are natural, and already well understood in today's Internet because of experience with dial up network access.

8. Acknowledgements

Thanks to Gopal Dommety, and Basavaraj Patil for participating in the Mobile IP subcommittee of the aaa-wg which was charged with formulating the requirements detailed in this document. Thanks to

N.

Asokan for perceptive comments to the mobile-ip mailing list. Some of the text of this document was taken from a draft co-authored by Pat Calhoun. Patrik Flykt suggested text about allowing AAA home domain functions to be separated from the domain managing the home address of the mobile computer.

The requirements in [section 5.5](#) and [section 3.1](#) were taken from a draft submitted by members of the TIA's TR45.6 Working Group.

Glass, Hiller, Jacobs, Perkins
20]

Expires 11 July 2000

[Page

We would like to acknowledge the work done by the authors of that draft: Tom Hiller, Pat Walsh, Xing Chen, Mark Munson, Gopal Dommety, Sanjeevan Sivalingham, Byng-Keun Lim, Pete McCann, Brent Hirschman, Serge Manning, Ray Hsu, Hang Koo, Mark Lipford, Pat Calhoun, Eric Jaques, Ed Campbell, and Yingchun Xu.

Glass, Hiller, Jacobs, Perkins
21]

Expires 11 July 2000

[Page

References

- [1] B. Aboba and M. Beadles. The Network Access Identifier. Request for Comments (Proposed Standard) [2486](#), Internet Engineering Task Force, January 1999.
- [2] B. Aboba and J. Vollbrecht. Proxy Chaining and Policy Implementation in Roaming. Internet Draft, Internet Engineering Task Force. [draft-ietf-roamops-auth-10.txt](#), February 1999. Work in progress.
- [3] B. Aboba and G. Zorn. Criteria for Evaluating Roaming Protocols. Request for Comments (Informational) [2477](#), Internet Engineering Task Force, December 1998.
- [4] S. Bradner. Key words for use in RFCs to Indicate Requirement Levels. Request for Comments (Best Current Practice) [2119](#), Internet Engineering Task Force, March 1997.
- [5] Ramon Caceres and Liviu Iftode. Improving the Performance of Reliable Transport Protocols in Mobile Computing Environments. IEEE Journal on Selected Areas in Communications, 13(5):850--857, June 1995.
- [6] Pat R. Calhoun and Charles E. Perkins. Mobile IP Network Address Identifier Extension. [draft-ietf-mobileip-mn-nai-07.txt](#), January 2000. (work in progress).
- [7] D. Harkins and D. Carrel. The Internet Key Exchange (IKE). Request for Comments (Proposed Standard) [2409](#), Internet Engineering Task Force, November 1998.
- [8] R. Housley, W. Ford, T. Polk, and D. Solo. Internet X.509 Public Key Infrastructure Certificate and CRL Profile. Internet Draft, Internet Engineering Task Force. [draft-ietf-pkix-ipki-part1-11.txt](#), September 1998. Work in progress.
- [9] J. Kohl and C. Neuman. The Kerberos Network Authentication Service (V5). Request for Comments (Proposed Standard) [1510](#), Internet Engineering Task Force, September 1993.
- [10] P. V. Mockapetris. Domain names - implementation and specification. Request for Comments (Standard) [1035](#), Internet Engineering Task Force, November 1987.

Glass, Hiller, Jacobs, Perkins
22]

Expires 11 July 2000

[Page

- [11] G. Montenegro and V. Gupta. Sun's SKIP Firewall Traversal for Mobile IP. Request for Comments (Informational) [2356](#), Internet Engineering Task Force, June 1998.
- [12] C. Perkins. IP Encapsulation within IP. Request for Comments (Proposed Standard) [2003](#), Internet Engineering Task Force, October 1996.
- [13] C. Perkins. IP Mobility Support. Request for Comments (Proposed Standard) [2002](#), Internet Engineering Task Force, October 1996.
- [14] C. Perkins. Minimal Encapsulation within IP. Request for Comments (Proposed Standard) [2004](#), Internet Engineering Task Force, October 1996.
- [15] C. Perkins and D. Johnson. Route Optimization in Mobile IP. Internet Draft, Internet Engineering Task Force. [draft-ietf-mobileip-optim-08.txt](#), February 1999. Work in progress.
- [16] C. Rigney, A. Rubens, W. Simpson, and S. Willens. Remote Authentication Dial In User Service (RADIUS). Request for Comments (Proposed Standard) [2138](#), Internet Engineering Task Force, April 1997.
- [17] J. Solomon and S. Glass. Mobile-IPv4 Configuration Option for PPP IPCP. Request for Comments (Proposed Standard) [2290](#), Internet Engineering Task Force, February 1998.

Addresses

The working group can be contacted via the current chairs:

Basavaraj Patil
Nortel Networks Inc.
2201 Lakeside Blvd.
Richardson, TX. 75082-4399
USA

Phone: +1 972-684-1489
EMail: bpatil@nortelnetworks.com

Phil Roberts
Motorola
1501 West Shure Drive
Arlington Heights, IL 60004
USA

Phone: +1 847-632-3148
EMail: QA3445@email.mot.com

Questions about this memo can be directed to:

Pat R. Calhoun
Network and Security Center
Sun Microsystems Laboratories
15 Network Circle
Menlo Park, California 94025
USA
Phone: +1 650-786-7733
pcalhoun@eng.sun.co
Fax: +1 650-786-6445

Gopal Dommety
IOS Network Protocols
Cisco Systems, Inc.
170 West Tasman Drive
San Jose, CA 95134-1706
USA
Phone: +1-408-525-1404
EMail: gdommety@cisco.com
Fax: +1 408-526-4952

Steven M. Glass
Sun Microsystems
1 Network Drive
Burlington, MA
01803
USA
Phone: +1-781-442-0504
EMail: steven.glass@sun.com

Stuart Jacobs
Secure Systems Department
GTE Laboratories
40 Sylvan Road
Waltham, MA 02451-1128
USA
Phone: +1 781-466-3076
EMail: sjacobs@gte.com
Fax: +1 781-466-2838

Tom Hiller
Lucent Technologies
Rm 2F-218
263 Shuman Blvd
Naperville, IL 60566
USA
email: tomhiller@lucent.com
phone: +1 630 979 7673
fax: +1 630 713 3663

Peter J. McCann
Lucent Technologies
Rm 2Z-305
263 Shuman Blvd
Naperville, IL 60566
USA
email: mccap@lucent.com
phone: +1 630 713 9359
fax: +1 630 713 4982

Basavaraj Patil
Wireless Technology Labs
Nortel Networks
2221 Lakeside Blvd.
Richardson, TX 75082-4399
94043
USA
Phone: +1 972-684-1489
EMail: bpatil@nortelnetworks.com
charliep@iprg.nokia.com
Fax: +1 972-685-3207

Charles E. Perkins
Communications Systems Lab
Nokia Research Center
313 Fairchild Drive
Mountain View, California
USA
Phone: +1-650 625-2986
EMail:
Fax: +1 650 625-2502

Glass, Hiller, Jacobs, Perkins
24]

Expires 11 July 2000

[Page