

March 1, 2019

PCEP Extension for WSON Routing and Wavelength Assignment

[draft-ietf-pce-wson-rwa-ext-17](#)

Abstract

This document provides the Path Computation Element communication Protocol (PCEP) extensions for the support of Routing and Wavelength Assignment (RWA) in Wavelength Switched Optical Networks (WSON). Path provisioning in WSONs requires a routing and wavelength assignment (RWA) process. From a path computation perspective, wavelength assignment is the process of determining which wavelength can be used on each hop of a path and forms an additional routing constraint to optical path computation.

Status of this Memo

This Internet-Draft is submitted to IETF in full conformance with the provisions of [BCP 78](#) and [BCP 79](#).

Internet-Drafts are working documents of the Internet Engineering Task Force (IETF), its areas, and its working groups. Note that other groups may also distribute working documents as Internet-Drafts.

Internet-Drafts are draft documents valid for a maximum of six months and may be updated, replaced, or obsoleted by other documents at any time. It is inappropriate to use Internet-Drafts as reference material or to cite them other than as "work in progress."

The list of current Internet-Drafts can be accessed at <http://www.ietf.org/ietf/1id-abstracts.txt>

The list of Internet-Draft Shadow Directories can be accessed at <http://www.ietf.org/shadow.html>.

This Internet-Draft will expire on September 1, 2019.

Copyright Notice

Copyright (c) 2019 IETF Trust and the persons identified as the document authors. All rights reserved.

This document is subject to [BCP 78](#) and the IETF Trust's Legal Provisions Relating to IETF Documents (<http://trustee.ietf.org/license-info>) in effect on the date of publication of this document. Please review these documents carefully, as they describe your rights and restrictions with respect to this document. Code Components extracted from this document must include Simplified BSD License text as described in Section 4.e of the [Trust Legal Provisions](#) and are provided without warranty as described in the Simplified BSD License.

Table of Contents

- [1. Terminology.....3](#)
- [2. Requirements Language.....3](#)
- [3. Introduction.....3](#)
- [4. Encoding of a RWA Path Request.....6](#)
 - [4.1. Wavelength Assignment \(WA\) Object.....7](#)
 - [4.2. Wavelength Selection TLV.....9](#)
 - [4.3. Wavelength Restriction Constraint TLV.....9](#)
 - [4.3.1. Link Identifier Field.....12](#)
 - [4.3.2. Wavelength Restriction Field.....14](#)
 - [4.4. Signal Processing Capability Restrictions.....15](#)
 - [4.4.1. Signal Processing Exclusion.....16](#)
 - [4.4.2. Signal Processing Inclusion.....18](#)
- [5. Encoding of a RWA Path Reply.....19](#)
 - [5.1. Wavelength Allocation TLV.....19](#)
 - [5.2. Error Indicator.....20](#)
 - [5.3. NO-PATH Indicator.....21](#)
- [6. Manageability Considerations.....22](#)
 - [6.1. Control of Function and Policy.....22](#)
 - [6.2. Liveness Detection and Monitoring.....22](#)
 - [6.3. Verifying Correct Operation.....22](#)
 - [6.4. Requirements on Other Protocols and Functional Components22](#)
 - [6.5. Impact on Network Operation.....23](#)

- [7. Security Considerations.....23](#)
- [8. IANA Considerations.....23](#)
 - [8.1. New PCEP Object: Wavelength Assignment Object.....23](#)
 - [8.2. WA Object Flag Field.....23](#)
 - [8.3. New PCEP TLV: Wavelength Selection TLV.....24](#)
 - [8.4. New PCEP TLV: Wavelength Restriction Constraint TLV.....24](#)
 - [8.5. Wavelength Restriction Constraint TLV Action Values.....25](#)
 - [8.6. New PCEP TLV: Wavelength Allocation TLV.....25](#)
 - [8.7. Wavelength Allocation TLV Flag Field.....25](#)
 - [8.8. New PCEP TLV: Optical Interface Class List TLV.....26](#)
 - [8.9. New PCEP TLV: Client Signal TLV.....26](#)
 - [8.10. New No-Path Reasons.....27](#)
 - [8.11. New Error-Types and Error-Values.....27](#)
 - [8.12. New Subobjects for the Exclude Route Object.....28](#)
 - [8.13. New Subobjects for the Include Route Object.....28](#)
 - [8.14. Request for Updated Note for LMP TE Link Object Class Type
.....28](#)
- [9. Acknowledgments.....29](#)
- [10. References.....29](#)
 - [10.1. Normative References.....29](#)
 - [10.2. Informative References.....30](#)
- [11. Contributors.....32](#)
- [Authors' Addresses.....33](#)

1. Terminology

This document uses the terminology defined in [[RFC4655](#)], and [[RFC5440](#)].

2. Requirements Language

The key words "MUST", "MUST NOT", "REQUIRED", "SHALL", "SHALL NOT", "SHOULD", "SHOULD NOT", "RECOMMENDED", "NOT RECOMMENDED", "MAY", and "OPTIONAL" in this document are to be interpreted as described in [BCP 14](#) [[RFC2119](#)] [[RFC8174](#)] when, and only when, they appear in all capitals, as shown here.

3. Introduction

[[RFC5440](#)] specifies the Path Computation Element (PCE) Communication Protocol (PCEP) for communications between a Path Computation Client (PCC) and a PCE, or between two PCEs. Such interactions include path computation requests and path computation replies as well as notifications of specific states related to the use of a PCE in the

context of Multiprotocol Label Switching (MPLS) and Generalized MPLS (GMPLS) Traffic Engineering.

A PCC is said to be any network component that makes such a request and may be, for instance, an Optical Switching Element within a Wavelength Division Multiplexing (WDM) network. The PCE, itself, can be located anywhere within the network, and may be within an optical switching element, a Network Management System (NMS) or Operational Support System (OSS), or may be an independent network server.

This document provides the PCEP extensions for the support of Routing and Wavelength Assignment (RWA) in Wavelength Switched Optical Networks (WSON) based on the requirements specified in [[RFC6163](#)] and [[RFC7449](#)].

WSON refers to WDM based optical networks in which switching is performed selectively based on the wavelength of an optical signal. The devices used in WSONs that are able to switch signals based on signal wavelength are known as Lambda Switch Capable (LSC). WSONs can be transparent or translucent. A transparent optical network is made up of optical devices that can switch but not convert from one wavelength to another, all within the optical domain. On the other hand, translucent networks include 3R regenerators (Re-amplification, Re-shaping, Re-timing) that are sparsely placed. The main function of the 3R regenerators is to convert one optical wavelength to another.

A Lambda Switch Capable (LSC) Label Switched Path (LSP) may span one or several transparent segments, which are delimited by 3R regenerators typically with electronic regenerator and optional wavelength conversion. Each transparent segment or path in WSON is referred to as an optical path. An optical path may span multiple fiber links and the path should be assigned the same wavelength for each link. In such case, the optical path is said to satisfy the wavelength-continuity constraint. Figure 1 illustrates the relationship between a LSC LSP and transparent segments (optical paths).

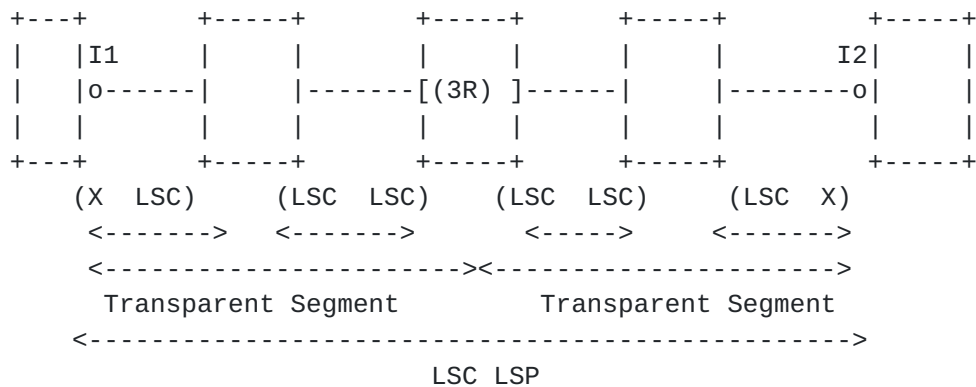

Figure 1 Illustration of a LSC LSP and transparent segments

Note that two transparent segments within a WSON LSP do not need to operate on the same wavelength (due to the wavelength conversion capabilities). Two optical channels that share a common fiber link cannot be assigned the same wavelength; otherwise, the two signals would interfere with each other. Note that advanced additional multiplexing techniques such as polarization based multiplexing are not addressed in this document since the physical layer aspects are not currently standardized. Therefore, assigning the proper wavelength on a path is an essential requirement in the optical path computation process.

When a switching node has the ability to perform wavelength conversion, the wavelength-continuity constraint can be relaxed, and a LSC Label Switched Path (LSP) may use different wavelengths on different links along its route from origin to destination. It is, however, to be noted that wavelength converters may be limited due to their relatively high cost, while the number of WDM channels that can be supported in a fiber is also limited. As a WSON can be composed of network nodes that cannot perform wavelength conversion, nodes with limited wavelength conversion, and nodes with full wavelength conversion abilities, wavelength assignment is an additional routing constraint to be considered in all optical path computation.

For example (see Figure 1), within a translucent WSON, a LSC LSP may be established between interfaces I1 and I2, spanning 2 transparent segments (optical paths) where the wavelength continuity constraint applies (i.e. the same unique wavelength must be assigned to the LSP at each TE link of the segment). If the LSC LSP induced a Forwarding Adjacency / TE link, the switching capabilities of the TE link would

be (X X) where X refers to the switching capability of I1 and I2. For example, X can be Packet Switch Capable (PSC), Time Division Multiplexing (TDM), etc.

This document aligns with GMPLS extensions for PCEP [[PCEP-GMPLS](#)] for generic properties such as label, label-set and label assignment noting that wavelength is a type of label. Wavelength restrictions and constraints are also formulated in terms of labels per [[RFC7579](#)].

The optical modulation properties, which are also referred to as signal compatibility, are already considered in signaling in [[RFC7581](#)] and [[RFC7688](#)]. In order to improve the signal quality and limit some optical effects several advanced modulation processing capabilities are used by the mechanisms specified in this document. These modulation capabilities contribute not only to optical signal quality checks but also constrain the selection of sender and receiver, as they should have matching signal processing capabilities. This document includes signal compatibility constraints as part of RWA path computation. That is, the signal processing capabilities (e.g., modulation and Forward Error Correction (FEC)) indicated by means of optical interface class (OIC) must be compatible between the sender and the receiver of the optical path across all optical elements.

This document, however, does not address optical impairments as part of RWA path computation. See [[RFC6566](#)] for the framework for optical impairments.

4. Encoding of a RWA Path Request

Figure 2 shows one typical PCE based implementation, which is referred to as the Combined Process (R&WA). With this architecture, the two processes of routing and wavelength assignment are accessed via a single PCE. This architecture is the base architecture specified in [[RFC6163](#)] and the PCEP extensions that are specified in this document are based on this architecture.

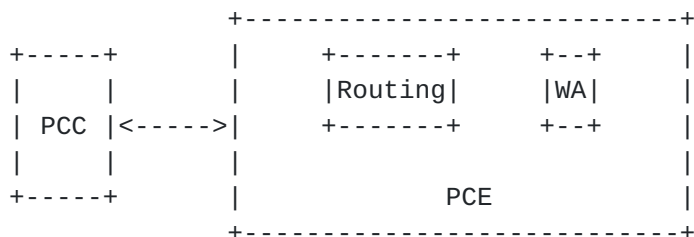

Figure 2 Combined Process (R&WA) architecture

4.1. Wavelength Assignment (WA) Object

Wavelength allocation can be performed by the PCE by different means:

(a) By means of Explicit Label Control [RFC3471] where the PCE allocates which label to use for each interface/node along the path. The allocated labels MAY appear after an interface route subobject.

(b) By means of a Label Set where the PCE provides a range of potential labels to allocate by each node along the path.

Option (b) allows distributed label allocation (performed during signaling) to complete wavelength assignment.

Additionally, given a range of potential labels to allocate, a PC Request SHOULD convey the heuristic / mechanism used for the allocation.

The format of a PCReq message per [RFC5440] after incorporating the Wavelength Assignment (WA) object is as follows:

```

<PCReq Message> ::= <Common Header>
                    [ <svec-list> ]
                    <request-list>
    
```

Where:

```

<request-list> ::= <request> [ <request-list> ]
<request> ::= <RP>
    
```

<END-POINTS>

<WA>

[other optional objects...]

If the WA object is present in the request, it MUST be encoded after the END-POINTS object as defined in [PCEP-GMPLS]. The WA Object is mandatory in this document. Orderings for the other optional objects are irrelevant.

WA Object-Class is (TBD1) (To be assigned by IANA).

WA Object-Type is 1.

The format of the WA object body is as follows:

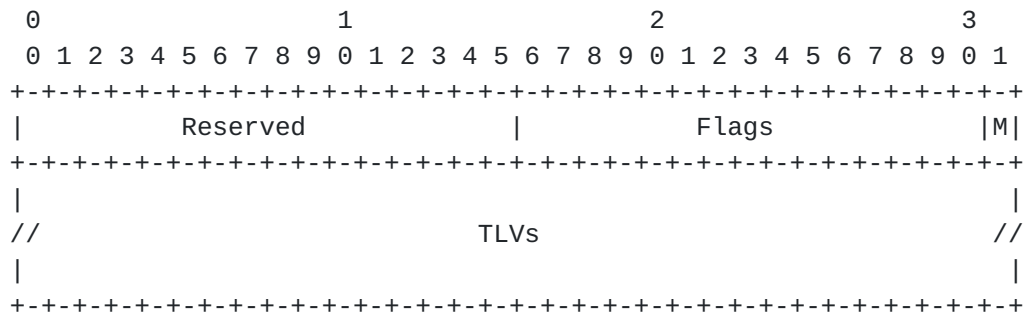

Figure 3 WA Object

o Reserved (16 bits): Reserved for future use and SHOULD be zeroed and ignored on receipt.

o Flags (16 bits)

One flag bit is allocated as follows:

- M (Mode - 1 bit): M bit is used to indicate the mode of wavelength assignment. When M bit is set to 1, this indicates that the label assigned by the PCE must be explicit. That is, the selected way to convey the allocated wavelength is by means of Explicit Label Control for each hop of a computed LSP. Otherwise (M bit is set to 0), the label assigned by the PCE need not be explicit (i.e., it can be suggested in the form of label set objects in the corresponding response, to allow distributed WA. If M is 0, the PCE MUST return a Label Set Field as described in [Section 2.6 of \[RFC7579\]](#) in the response. See [Section 5](#) of this document for the encoding discussion of a Label Set Field in a PCRep message.

All unused flags SHOULD be zeroed. IANA is to create a new registry to manage the Flag field of the WA object.

- o TLVs (variable). In the TLVs field, the following two TLVs are defined. At least one TLV MUST be present.
 - Wavelength Selection TLV: A TLV of type (TBD2) with fixed length of 32 bits indicating the wavelength selection. See [Section 4.2](#) for details.
 - Wavelength Restriction Constraint TLV: A TLV of type (TBD3) with variable length indicating wavelength restrictions. See [Section 4.3](#) for details.

[4.2. Wavelength Selection TLV](#)

The Wavelength Selection TLV is used to indicate the wavelength selection constraint in regard to the order of wavelength assignment to be returned by the PCE. This TLV is only applied when M bit is set in the WA Object specified in [Section 4.1](#). This TLV MUST NOT be used when the M bit is cleared.

The encoding of this TLV is specified as the Wavelength Selection Sub-TLV in [Section 4.2.2 of \[RFC7689\]](#). IANA is to allocate a new TLV type, Wavelength Selection TLV type (TBD2).

[4.3. Wavelength Restriction Constraint TLV](#)

For any request that contains a wavelength assignment, the requester (PCC) MUST specify a restriction on the wavelengths to be used. This restriction is to be interpreted by the PCE as a constraint on the tuning ability of the origination laser transmitter or on any other

maintenance related constraints. Note that if the LSP LSC spans different segments, the PCE must have mechanisms to know the tunability restrictions of the involved wavelength converters / regenerators, e.g. by means of the Traffic Engineering Database (TED) either via IGP or Network Management System (NMS). Even if the PCE knows the tunability of the transmitter, the PCC must be able to apply additional constraints to the request.

The format of the Wavelength Restriction Constraint TLV is as follows:

```
<Wavelength Restriction Constraint> ::=
    (<Action> <Count> <Reserved>
     <Link Identifiers> <Wavelength Restriction>)...
```

Where

```
<Link Identifiers> ::= <Link Identifier> [<Link Identifiers>]
```

See [Section 4.3.1](#). for the encoding of the Link Identifiers Field.

These fields (i.e., <Action>, <Link Identifiers> and <Wavelength Restriction>, etc.) MAY appear together more than once to be able to specify multiple actions and their restrictions.

IANA is to allocate a new TLV type, Wavelength Restriction Constraint TLV type (TBD3).

The TLV data is defined as follows:

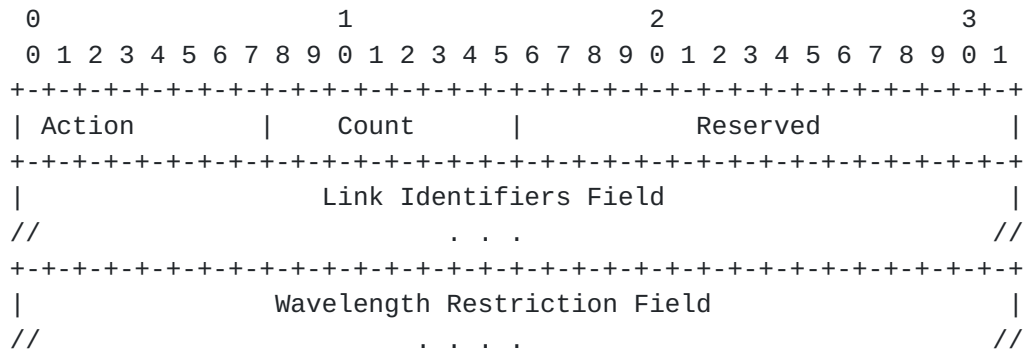

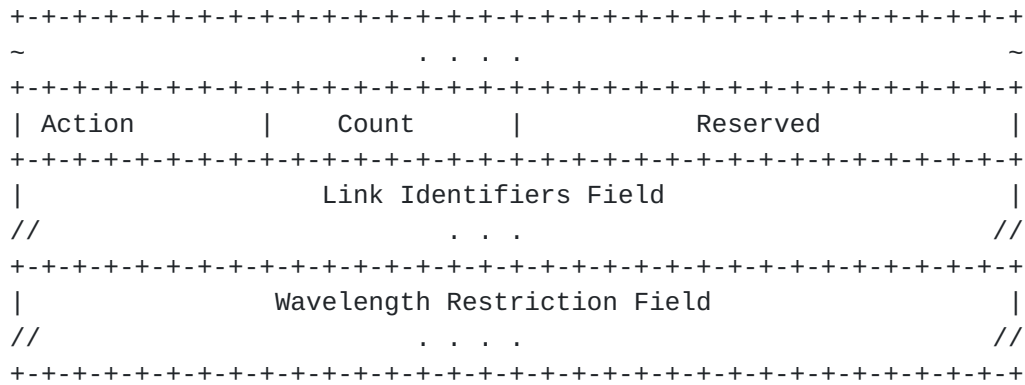

Figure 4 Wavelength Restriction Constraint TLV Encoding

- o Action (8 bits):
 - o 0 - Inclusive List indicates that one or more link identifiers are included in the Link Set. Each identifies a separate link that is part of the set.
 - o 1 - Inclusive Range indicates that the Link Set defines a range of links. It contains two link identifiers. The first identifier indicates the start of the range (inclusive). The second identifier indicates the end of the range (inclusive). All links with numeric values between the bounds are considered to be part of the set. A value of zero in either position indicates that there is no bound on the corresponding portion of the range.
 - o 2-255 - For future use

IANA is to create a new registry to manage the Action values of the Wavelength Restriction Constraint TLV.

If PCE receives an unrecognized Action value, the PCE MUST send a PCErr message with a PCEP-ERROR Object (Error-Type=TBD8) and an Error-value (Error-value=3). See [Section 5.2](#) for details.

Note that "links" are assumed to be bidirectional.

- o Count (8 bits): The number of the link identifiers

Note that a PCC MAY add a Wavelength restriction that applies to all links by setting the Count field to zero and specifying just a set of wavelengths.

Note that all link identifiers in the same list MUST be of the same type.

- o Reserved (16 bits): Reserved for future use and SHOULD be zeroed and ignored on receipt.
- o Link Identifiers: Identifies each link ID for which restriction is applied. The length is dependent on the link format and the Count field. See [Section 4.3.1](#). for Link Identifier encoding.
- o Wavelength Restriction: See [Section 4.3.2](#). for the Wavelength Restriction Field encoding.

Various encoding errors are possible with this TLV (e.g., not exactly two link identifiers with the range case, unknown identifier types, no matching link for a given identifier, etc.). To indicate errors associated with this encoding, a PCEP speaker MUST send a PCErr message with Error-Type=TBD8 and Error-value=3. See [Section 5.1](#) for the details.

[4.3.1](#). Link Identifier Field

The link identifier field can be an IPv4 [[RFC3630](#)], IPv6 [[RFC5329](#)] or unnumbered interface ID [[RFC4203](#)].

<Link Identifier> ::=

<IPv4 Address> | <IPv6 Address> | <Unnumbered IF ID>

The encoding of each case is as follows:

IPv4 Address Field

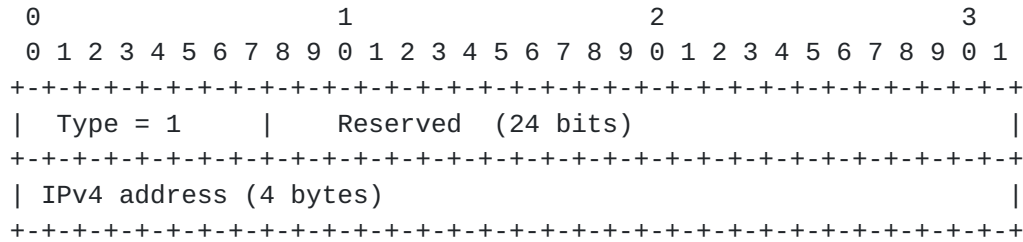

IPv6 Address Field

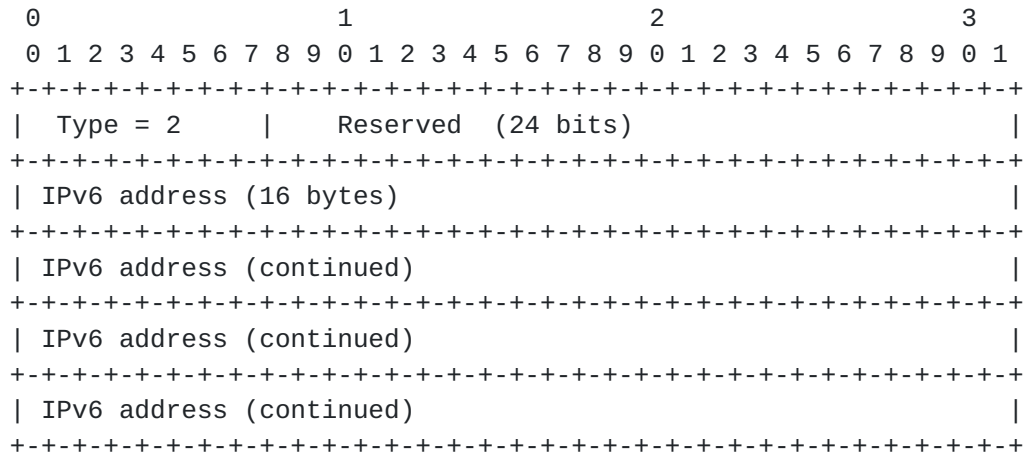

Unnumbered Interface ID Address Field

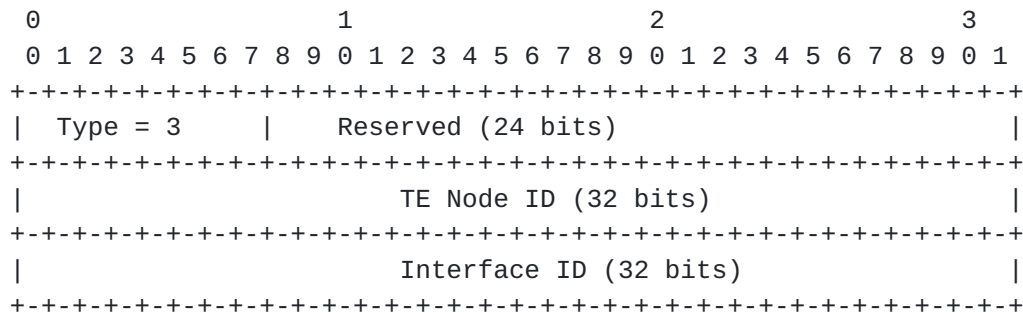

o Type (8 bits): It indicates the type of the link identifier.

- 1 - Exclusive List
- 2 - Inclusive Range
- 3 - Exclusive Range
- 4 - Bitmap Set

Num Labels (12 bits): It is generally the number of labels. It has a specific meaning depending on the action value.

Length (16 bits): It is the length in bytes of the entire Wavelength Restriction field.

Identifier (9 bits): The Identifier is always set to 0. If PCC receives the value of the identifier other than 0, it will ignore.

See Sections [2.6.1](#) - [2.6.3](#) of [[RFC7579](#)] for details on additional field discussion for each action.

[4.4. Signal Processing Capability Restrictions](#)

Path computation for WSON includes checking of signal processing capabilities at each interface against requested capability; the PCE MUST have mechanisms to know the signal processing capabilities at each interface, e.g. by means of the Traffic Engineering Database (TED) either via IGP or Network Management System (NMS). Moreover, a PCC should be able to indicate additional restrictions to signal processing compatibility, either on the endpoint or any given link.

The supported signal processing capabilities considered in the RWA Information Model [[RFC7446](#)] are:

- o Optical Interface Class List
- o Bit Rate
- o Client Signal

The Bit Rate restriction is already expressed in [[PCEP-GMPLS](#)] in the BANDWIDTH object.

In order to support the Optical Interface Class information and the Client Signal information new TLVs are introduced as endpoint-restriction in the END-POINTS type Generalized endpoint:

- o Client Signal TLV
- o Optical Interface Class List TLV

The END-POINTS type generalized endpoint is extended as follows:

```
<endpoint-restriction> ::=
    <LABEL-REQUEST> <label-restriction-list>

<label-restriction-list> ::= <label-restriction>
    [<label-restriction-list>]

<label-restriction> ::= (<LABEL-SET>|
    [<Wavelength Restriction Constraint>]
    [<signal-compatibility-restriction>])
```

Where

```
<signal-compatibility-restriction> ::=
    [<Optical Interface Class List>] [<Client Signal>]
```

The Wavelength Restriction Constraint TLV is defined in [Section 4.3](#).

A new TLV for the Optical Interface Class List TLV (TBD5) is defined, and the encoding of the value part of the Optical Interface Class List TLV is described in [Section 4.1 of \[RFC7581\]](#).

A new TLV for the Client Signal Information TLV (TBD6) is defined, and the encoding of the value part of the Client Signal Information TLV is described in [Section 4.2 of \[RFC7581\]](#).

[4.4.1](#). Signal Processing Exclusion

The PCC/PCE should be able to exclude particular types of signal processing along the path in order to handle client restriction or multi-domain path computation. [\[RFC5440\]](#) defines how Exclude Route Object (XRO) subobject is used. In this draft, we add two new XRO Signal Processing Exclusion Subobjects.

The first XRO subobject type (TBD9) is the Optical Interface Class List Field defined as follows:

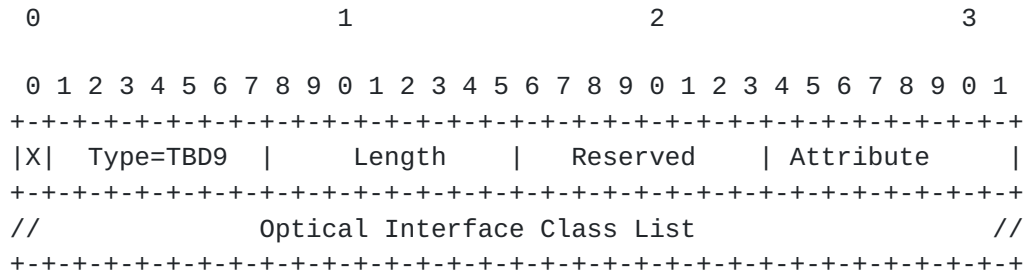

Figure 5 Optical Interface Class List XRO Subobject

Refer to [RFC5521] for the definition of X, Length and Attribute.

Type (7 bits): The Type of the Signaling Processing Exclusion Field. The TLV Type value (TBD9) is to be assigned by the IANA for the Optical Interface Class List XRO Subobject Type.

Reserved bits (8 bits) are for future use and SHOULD be zeroed and ignored on receipt.

The Attribute field (8 bits): [RFC5521] defines several Attribute values; the only permitted Attribute values for this field are 0 (Interface) or 1 (Node).

The Optical Interface Class List is encoded as described in Section 4.1 of [RFC7581].

The second XRO subobject type (TBD10) is the Client Signal Information defined as follows:

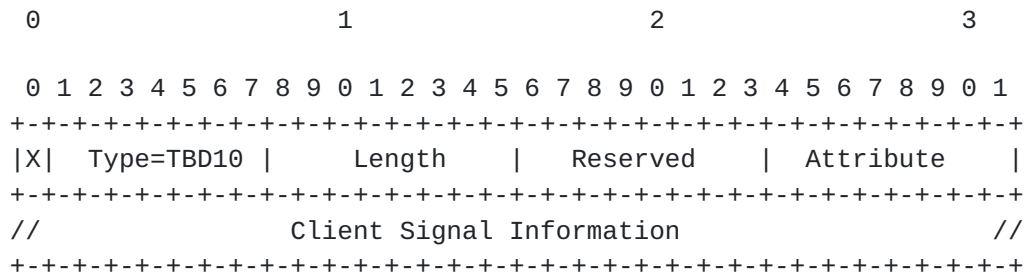

Figure 6 Client Signal Information XRO Subobject

Refer to [[RFC5521](#)] for the definition of X, Length and Attribute.

Type (7 bits): The Type of the Signaling Processing Exclusion Field. The TLV Type value (TBD10) is to be assigned by the IANA for the Client Signal Information XRO Subobject Type.

Reserved bits (8 bits) are for future use and SHOULD be zeroed and ignored on receipt.

The Attribute field (8 bits): [[RFC5521](#)] defines several Attribute values; the only permitted Attribute values for this field are 0 (Interface) or 1 (Node).

The Client Signal Information is encoded as described in [Section 4.2 of \[RFC7581\]](#).

The XRO needs to support the new Signaling Processing Exclusion XRO Subobject types:

Type	XRO Subobject Type
TBD9	Optical Interface Class List
TBD10	Client Signal Information

[4.4.2. Signal Processing Inclusion](#)

Similar to the XRO subobject, the PCC/PCE should be able to include particular types of signal processing along the path in order to handle client restriction or multi-domain path computation. [[RFC5440](#)] defines how Include Route Object (IRO) subobject is used. In this draft, we add two new Signal Processing Inclusion Subobjects.

The IRO needs to support the new IRO Subobject types (TBD11 and TBD12) for the PCEP IRO object [[RFC5440](#)]:

Type	IRO Subobject Type
------	--------------------

TBD11 Optical Interface Class List

TBD12 Client Signal Information

The encoding of the Signal Processing Inclusion subobjects is similar to Section 4.4.1 where the 'X' field is replaced with 'L' field, all the other fields remains the same. The 'L' field is described in [RFC3209].

5. Encoding of a RWA Path Reply

This section provides the encoding of a RWA Path Reply for wavelength allocation request as discussed in Section 4.

5.1. Wavelength Allocation TLV

Recall that wavelength allocation can be performed by the PCE by different means:

- (a) By means of Explicit Label Control (ELC) where the PCE allocates which label to use for each interface/node along the path.
- (b) By means of a Label Set where the PCE provides a range of potential labels to allocate by each node along the path.

Option (b) allows distributed label allocation (performed during signaling) to complete wavelength allocation.

The Wavelength Allocation TLV type is TBD4 (See Section 8.4). Note that this TLV is used for both (a) and (b). The TLV data is defined as follows:

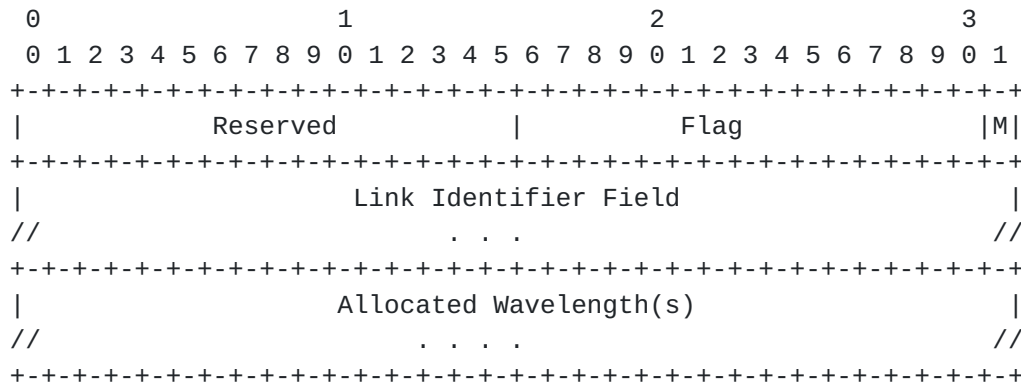

Figure 7 Wavelength Allocation TLV Encoding

- o Reserved (16 bits): Reserved for future use.
- o Flags (16 bits)

One flag bit is allocated as follows:

- . M (Mode): 1 bit
 - 0 indicates the allocation is under Explicit Label Control.
 - 1 indicates the allocation is expressed in Label Sets.

IANA is to create a new registry to manage the Flag field (TBD14) of the Wavelength Allocation TLV.

Note that all link identifiers in the same list must be of the same type.

- o Link Identifier: Identifies the interface to which assignment wavelength(s) is applied. See [Section 4.3.1](#) for Link Identifier encoding.
- o Allocated Wavelength(s): Indicates the allocated wavelength(s) to be associated with the Link Identifier. See [Section 4.3.2](#) for encoding details.

This TLV is carried in a PCRep message as an attribute TLV [[RFC5420](#)] in the Hop Attribute Subobjects [[RFC7570](#)] in the ERO [[RFC5440](#)].

[5.2. Error Indicator](#)

To indicate errors associated with the RWA request, a new Error Type (TBD8) and subsequent error-values are defined as follows for inclusion in the PCEP-ERROR Object:

A new Error-Type (TBD8) and subsequent error-values are defined as follows:

- o Error-Type=TBD8; Error-value=1: if a PCE receives a RWA request and the PCE is not capable of processing the request due to insufficient memory, the PCE MUST send a PCErr message with a PCEP-ERROR Object (Error-Type=TBD8) and an Error-value (Error-value=1). The PCE stops processing the request. The corresponding RWA request MUST be cancelled at the PCC.
- o Error-Type=TBD8; Error-value=2: if a PCE receives a RWA request and the PCE is not capable of RWA computation, the PCE MUST send a PCErr message with a PCEP-ERROR Object (Error-Type=TBD8) and an Error-value (Error-value=2). The PCE stops processing the request. The corresponding RWA computation MUST be cancelled at the PCC.
- o Error-Type=TBD8; Error-value=3: if a PCE receives a RWA request and there are syntactical encoding errors (e.g., not exactly two link identifiers with the range case, unknown identifier types, no matching link for a given identifier, unknown Action value, etc.), the PCE MUST send a PCErr message with a PCEP-ERROR Object (Error-Type=TBD8) and an Error-value (Error-value=3).

5.3. NO-PATH Indicator

To communicate the reason(s) for not being able to find RWA for the path request, the NO-PATH object can be used in the corresponding response. The format of the NO-PATH object body is defined in [\[RFC5440\]](#). The object may contain a NO-PATH-VECTOR TLV to provide additional information about why a path computation has failed.

One new bit flag is defined to be carried in the Flags field in the NO-PATH-VECTOR TLV carried in the NO-PATH Object.

- o Bit TBD7: When set, the PCE indicates no feasible route was found that meets all the constraints (e.g., wavelength restriction, signal compatibility, etc.) associated with RWA.

6. Manageability Considerations

Manageability of WSON Routing and Wavelength Assignment (RWA) with PCE must address the following considerations:

6.1. Control of Function and Policy

In addition to the parameters already listed in [Section 8.1 of \[RFC5440\]](#), a PCEP implementation SHOULD allow configuration of the following PCEP session parameters on a PCC:

- o The ability to send a WSON RWA request.

In addition to the parameters already listed in [Section 8.1 of \[RFC5440\]](#), a PCEP implementation SHOULD allow configuration of the following PCEP session parameters on a PCE:

- o The support for WSON RWA.
- o A set of WSON RWA specific policies (authorized sender, request rate limiter, etc).

These parameters may be configured as default parameters for any PCEP session the PCEP speaker participates in, or may apply to a specific session with a given PCEP peer or a specific group of sessions with a specific group of PCEP peers.

6.2. Liveness Detection and Monitoring

Mechanisms defined in this document do not imply any new liveness detection and monitoring requirements in addition to those already listed in [section 8.3 of \[RFC5440\]](#).

6.3. Verifying Correct Operation

Mechanisms defined in this document do not imply any new verification requirements in addition to those already listed in [section 8.4 of \[RFC5440\]](#)

6.4. Requirements on Other Protocols and Functional Components

The PCEP Link-State mechanism [[PCEP-LS](#)] may be used to advertise WSON RWA path computation capabilities to PCCs.

6.5. Impact on Network Operation

Mechanisms defined in this document do not imply any new network operation requirements in addition to those already listed in [section 8.6 of \[RFC5440\]](#).

7. Security Considerations

The security considerations discussed in [\[RFC5440\]](#) are relevant for this document, this document does not introduce any new security issues. If an operator wishes to keep private the information distributed by WSON, PCEPS [\[RFC8253\]](#) SHOULD be used.

8. IANA Considerations

IANA maintains a registry of PCEP parameters. IANA has made allocations from the sub-registries as described in the following sections.

8.1. New PCEP Object: Wavelength Assignment Object

As described in [Section 4.1](#), a new PCEP Object is defined to carry wavelength assignment related constraints. IANA is to allocate the following from "PCEP Objects" sub-registry (<http://www.iana.org/assignments/pcep/pcep.xhtml#pcep-objects>):

Object Class Value	Name	Object Type	Reference
TBD1	WA	1: Wavelength Assignment	[This.I-D]

8.2. WA Object Flag Field

As described in [Section 4.1](#), IANA is to create a registry to manage the Flag field of the WA object. New values are to be assigned by Standards Action [\[RFC8126\]](#). Each bit should be tracked with the following qualities:

- o Bit number (counting from bit 0 as the most significant bit)
- o Capability description
- o Defining RFC

The following values are defined in this document:

One bit is defined for the WA Object flag in this document:

Codespace of the Flag field (WA Object)

Bit	Description	Reference
0-14	Unassigned	[This.I-D]
15	Explicit Label Control	[This.I-D]

8.3. New PCEP TLV: Wavelength Selection TLV

As described in Sections 4.2, a new PCEP TLV is defined to indicate wavelength selection constraints. IANA is to allocate this new TLV from the "PCEP TLV Type Indicators" subregistry (<http://www.iana.org/assignments/pcep/pcep.xhtml#pcep-tlv-type-indicators>).

Value	Description	Reference
TBD2	Wavelength Selection	[This.I-D]

8.4. New PCEP TLV: Wavelength Restriction Constraint TLV

As described in Sections 4.3, a new PCEP TLV is defined to indicate wavelength restriction constraints. IANA is to allocate this new TLV from the "PCEP TLV Type Indicators" subregistry (<http://www.iana.org/assignments/pcep/pcep.xhtml#pcep-tlv-type-indicators>).

Value	Description	Reference
TBD3	Wavelength Restriction	[This.I-D]

Constraint

8.5. Wavelength Restriction Constraint TLV Action Values

As described in [Section 4.3](#), IANA is to allocate a new registry to manage the Action values of the Action field in the Wavelength Restriction Constraint TLV. New values are assigned by Standards Action [[RFC8126](#)]. Each value should be tracked with the following qualities: value, meaning, and defining RFC. The following values are defined in this document:

Value	Meaning	Reference
0	Inclusive List	[This.I-D]
1	Inclusive Range	[This.I-D]
2-255	Reserved	[This.I-D]

8.6. New PCEP TLV: Wavelength Allocation TLV

As described in [Section 5.1](#), a new PCEP TLV is defined to indicate the allocation of wavelength(s) by the PCE in response to a request by the PCC. IANA is to allocate this new TLV from the "PCEP TLV Type Indicators" subregistry (<http://www.iana.org/assignments/pcep/pcep.xhtml#pcep-tlv-type-indicators>).

Value	Description	Reference
TBD4	Wavelength Allocation	[This.I-D]

8.7. Wavelength Allocation TLV Flag Field

As described in [Section 5.1](#), IANA is to allocate a registry to manage the Flag field of the Wavelength Allocation TLV. New values are to be assigned by Standards Action [[RFC8126](#)]. Each bit should be tracked with the following qualities:

- o Bit number (counting from bit 0 as the most significant bit)

- o Capability description
- o Defining RFC

One bit is defined for the Wavelength Allocation flag in this - document:

Codespace of the Flag field (Wavelength Allocation TLV)

Bit	Description	Reference
0-14	Unassigned	[This.I-D]
15	Wavelength Allocation Mode	[This.I-D]

8.8. New PCEP TLV: Optical Interface Class List TLV

As described in [Section 4.4](#), a new PCEP TLV is defined to indicate the optical interface class list. IANA is to allocate this new TLV from the "PCEP TLV Type Indicators" subregistry (<http://www.iana.org/assignments/pcep/pcep.xhtml#pcep-tlv-type-indicators>).

Value	Description	Reference
TBD5	Optical Interface Class List	[This.I-D]

8.9. New PCEP TLV: Client Signal TLV

As described in [Section 4.4](#), a new PCEP TLV is defined to indicate the client signal information. IANA is to allocate this new TLV from the "PCEP TLV Type Indicators" subregistry (<http://www.iana.org/assignments/pcep/pcep.xhtml#pcep-tlv-type-indicators>).

Value	Description	Reference

TBD6

Client Signal Information [This.I-D]

8.10. New No-Path Reasons

As described in [Section 5.3](#), a new bit flag are defined to be carried in the Flags field in the NO-PATH-VECTOR TLV carried in the NO-PATH Object. This flag, when set, indicates that no feasible route was found that meets all the RWA constraints (e.g., wavelength restriction, signal compatibility, etc.) associated with a RWA path computation request.

IANA is to allocate this new bit flag from the "PCEP NO-PATH-VECTOR TLV Flag Field" subregistry (<http://www.iana.org/assignments/pcep/pcep.xhtml#no-path-vector-tlv>).

Bit	Description	Reference
TBD7	No RWA constraints met	[This.I-D]

8.11. New Error-Types and Error-Values

As described in [Section 5.2](#), new PCEP error codes are defined for WSON RWA errors. IANA is to allocate from the "PCEP-ERROR Object Error Types and Values" sub-registry (<http://www.iana.org/assignments/pcep/pcep.xhtml#pcep-error-object>).

Error-Type	Meaning	Error-Value	Reference
TBD8	WSON RWA Error	0: Unassigned	[This.I-D]
		1: Insufficient Memory	[This.I-D]
		2: RWA computation Not supported	[This.I-D]

3: Syntactical Encoding error [This.I-D]

4-255: Unassigned [This.I-D]

8.12. New Subobjects for the Exclude Route Object

As described in Section 4.4.1, the "PCEP Parameters" registry contains a subregistry "PCEP Objects" with an entry for the Exclude Route Object (XRO). IANA is requested to add further subobjects that can be carried in the XRO as follows:

Subobject	Type	Reference

TBD9	Optical Interface Class List	[This.I-D]
TBD10	Client Signal Information	[This.I-D]

8.13. New Subobjects for the Include Route Object

As described in Section 4.4.2, the "PCEP Parameters" registry contains a subregistry "PCEP Objects" with an entry for the Include Route Object (IRO). IANA is requested to add further subobjects that can be carried in the IRO as follows:

Subobject	Type	Reference

TBD11	Optical Interface Class List	[This.I-D]
TBD12	Client Signal Information	[This.I-D]

8.14. Request for Updated Note for LMP TE Link Object Class Type

As discussed in Section 4.3.1, the registry created for Link Management Protocol (LMP) [RFC4204] for "TE Link Object Class Type name space": <https://www.iana.org/assignments/lmp-parameters/lmp-parameters.xhtml#lmp-parameters-15> is requested for the updated

introductory note that the values have additional usage for the Link Identifier Type field.

9. Acknowledgments

The authors would like to thank Adrian Farrel, Julien Meuric, Dhruv Dhody and Benjamin Kaduk for many helpful comments that greatly improved the contents of this draft.

10. References

10.1. Normative References

- [RFC2119] Bradner, S., "Key words for use in RFCs to Indicate Requirement Levels", [BCP 14](#), [RFC 2119](#), March 1997.
- [RFC3209] D. Awduche, L. Berger, D. Gan, T. Li, V. Srinivasan, G. Swallow, "RSVP-TE: Extensions to RSVP for LSP Tunnels", [RFC 3209](#), December 2001.
- [RFC3630] D. Katz, K. Kompella, D. Yeung, "Traffic Engineering (TE) Extensions to OSPF Version 2", [RFC 3630](#), September 2003.
- [RFC5329] A. Lindem, Ed., "Traffic Engineering Extensions to OSPF Version 3", [RFC 5329](#), September 2008.
- [RFC5440] JP. Vasseur, Ed., JL. Le Roux, Ed., "Path Computation Element (PCE) Communication Protocol (PCEP)", [RFC 5440](#), March 2009.
- [RFC6205] Tomohiro, O. and D. Li, "Generalized Labels for Lambda-Switching Capable Label Switching Routers", [RFC 6205](#), January, 2011.
- [RFC7570] C. Margaria, et al., "Label Switched Path (LSP) Attribute in the Explicit Route Object (ERO)", [RFC 7570](#), July 2015.
- [RFC7579] G. Bernstein and Y. Lee, "General Network Element Constraint Encoding for GMPLS Controlled Networks", [RFC 7579](#), June 2015.

- [RFC7581] G. Bernstein and Y. Lee, "Routing and Wavelength Assignment Information Encoding for Wavelength Switched Optical Networks", [RFC7581](#), June 2015.
- [RFC7689] Bernstein et al., "Signaling Extensions for Wavelength Switched Optical Networks", [RFC 7689](#), November 2015.
- [RFC7688] Y. Lee, and G. Bernstein, "OSPF Enhancement for Signal and Network Element Compatibility for Wavelength Switched Optical Networks", [RFC 7688](#), November 2015.
- [RFC8174] B. Leiba, "Ambiguity of Uppercase vs Lowercase in [RFC 2119](#) Key Words", [RFC 8174](#), May 2017.
- [RFC8253] D. Lopez, O. Gonzalez de Dios, Q. Wu, D. Dhody, "PCEPS: Usage of TLS to Provide a Secure Transport for the Path Computation Element Communication Protocol (PCEP)", [RFC 8253](#), October 2017.
- [PCEP-GMPLS] C. Margaria, et al., "PCEP extensions for GMPLS", [draft-ietf-pce-gmpls-pcep-extensions](#), work in progress.

10.2. Informative References

- [RFC3471] Berger, L. (Editor), "Generalized Multi-Protocol Label Switching (GMPLS) Signaling Functional Description", [RFC 3471](#). January 2003.
- [RFC4203] K. Kompella, Ed., Y. Rekhter, Ed., "OSPF Extensions in Support of Generalized Multi-Protocol Label Switching (GMPLS)", [RFC 4203](#), October 2005.
- [RFC4204] J. Lang, Ed., "Link Management Protocol (LMP)", [RFC 4204](#), October 2005.
- [RFC4655] A. Farrel, JP. Vasseur, G. Ash, "A Path Computation Element (PCE)-Based Architecture", [RFC 4655](#), August 2006.
- [RFC5420] Farrel, A. "Encoding of Attributes for MPLS LSP Establishment Using Resource Reservation Protocol Traffic Engineering (RSVP-TE)", [RFC5420](#), February 2009.

- [RFC5440] Vasseur, JP., Ed. and JL. Le Roux, Ed., "Path Computation Element (PCE) communication Protocol", [RFC 5440](#), March 2009. [RFC5521](#)] Oki, E, T. Takeda, and A. Farrel, "Extensions to the Path Computation Element Communication Protocol (PCEP) for Route Exclusions", [RFC 5521](#), April 2009.
- [RFC6163] Lee, Y. and Bernstein, G. (Editors), and W. Imajuku, "Framework for GMPLS and PCE Control of Wavelength Switched Optical Networks", [RFC 6163](#), March 2011.
- [RFC6566] Lee, Y. and Bernstein, G. (Editors), "A Framework for the Control of Wavelength Switched Optical Networks (WSONs) with Impairments", [RFC 6566](#), March 2012.
- [RFC7446] Y. Lee, G. Bernstein, (Editors), "Routing and Wavelength Assignment Information Model for Wavelength Switched Optical Networks", [RFC 7446](#), February 2015.
- [RFC7449] Y. Lee, G. Bernstein, (Editors), "Path Computation Element Communication Protocol (PCEP) Requirements for Wavelength Switched Optical Network (WSON) Routing and Wavelength Assignment", [RFC 7449](#), February 2015.
- [PCEP-LS] Y. Lee, et al., "PCEP Extension for Distribution of Link-State and TE information for Optical Networks", [draft-lee-pcep-pcep-ls-optical](#), work in progress.
- [RFC8126] M. Cotton, B. Leiba, T. Narten, "Guidelines for Writing an IANA Considerations Section in RFCs", [RFC 8126](#), June 2017.

11. Contributors

Fatai Zhang
Huawei Technologies
Email: zhangfatai@huawei.com

Cyril Margaria
Nokia Siemens Networks
St Martin Strasse 76
Munich, 81541
Germany
Phone: +49 89 5159 16934
Email: cyril.margaria@nsn.com

Oscar Gonzalez de Dios
Telefonica Investigacion y Desarrollo
C/ Emilio Vargas 6
Madrid, 28043
Spain
Phone: +34 91 3374013
Email: ogondio@tid.es

Greg Bernstein
Grotto Networking
Fremont, CA, USA
Phone: (510) 573-2237
Email: gregb@grotto-networking.com

Authors' Addresses

Young Lee, Editor
Huawei Technologies
5700 Tennyson Parkway Suite 600
Plano, TX 75024, USA
Email: leeyoung@huawei.com

Ramon Casellas, Editor
CTTC PMT Ed B4 Av. Carl Friedrich Gauss 7
08860 Castelldefels (Barcelona)
Spain
Phone: (34) 936452916
Email: ramon.casellas@cttc.es