

Networking Working Group
Internet-Draft
Intended status: Informational
Expires: October 22, 2009

K. Pister, Ed.
Dust Networks
P. Thubert, Ed.
Cisco Systems
S. Dwars
Shell
T. Phinney
April 20, 2009

Industrial Routing Requirements in Low Power and Lossy Networks
draft-ietf-roll-indus-routing-reqs-05

Status of this Memo

This Internet-Draft is submitted to IETF in full conformance with the provisions of [BCP 78](#) and [BCP 79](#).

Internet-Drafts are working documents of the Internet Engineering Task Force (IETF), its areas, and its working groups. Note that other groups may also distribute working documents as Internet-Drafts.

Internet-Drafts are draft documents valid for a maximum of six months and may be updated, replaced, or obsoleted by other documents at any time. It is inappropriate to use Internet-Drafts as reference material or to cite them other than as "work in progress."

The list of current Internet-Drafts can be accessed at <http://www.ietf.org/ietf/lid-abstracts.txt>.

The list of Internet-Draft Shadow Directories can be accessed at <http://www.ietf.org/shadow.html>.

This Internet-Draft will expire on October 22, 2009.

Copyright Notice

Copyright (c) 2009 IETF Trust and the persons identified as the document authors. All rights reserved.

This document is subject to [BCP 78](#) and the IETF Trust's Legal Provisions Relating to IETF Documents in effect on the date of publication of this document (<http://trustee.ietf.org/license-info>). Please review these documents carefully, as they describe your rights and restrictions with respect to this document.

Internet-Draft

roll-indus-routing-reqs

April 2009

Abstract

The wide deployment of lower cost wireless devices will significantly improve the productivity and safety of the plants while increasing the efficiency of the plant workers by extending the information set available about the plant operations. The aim of this document is to analyze the functional requirements for a routing protocol used in industrial Low power and Lossy Networks (LLN) of field devices.

Requirements Language

The key words "MUST", "MUST NOT", "REQUIRED", "SHALL", "SHALL NOT", "SHOULD", "SHOULD NOT", "RECOMMENDED", "MAY", and "OPTIONAL" in this document are to be interpreted as described in [RFC 2119](#) [[RFC2119](#)].

Table of Contents

1.	Introduction	3
2.	Terminology	3
3.	Overview	4
3.1.	Applications and Traffic Patterns	5
3.2.	Network Topology of Industrial Applications	8
3.2.1.	The Physical Topology	10
3.2.2.	Logical Topologies	12
4.	Traffic Characteristics	13
4.1.	Service Parameters	14
4.2.	Configurable Application Requirement	15
4.3.	Different Routes for Different Flows	15
5.	Reliability Requirements	15
6.	Device-Aware Routing Requirements	17
7.	Broadcast/Multicast	18
8.	Route Establishment Time	19
9.	Mobility	20
10.	Manageability	21
11.	Security	22
12.	IANA Considerations	23
13.	Acknowledgements	23
14.	References	24
14.1.	Normative References	24
14.2.	Informative References	24
14.3.	External Informative References	24
	Authors' Addresses	24

Internet-Draft

roll-indus-routing-reqs

April 2009

1. Introduction

Information Technology (IT) is already, and increasingly will be applied to industrial Control Technology (CT) in application areas where those IT technologies can be constrained sufficiently by Service Level Agreements (SLA) or other modest change that they are able to meet the operational needs of industrial CT. When that happens, the CT benefits from the large intellectual, experiential and training investment that has already occurred in those IT precursors. One can conclude that future reuse of additional IT protocols for industrial CT will continue to occur due to the significant intellectual, experiential and training economies which result from that reuse.

Following that logic, many vendors are already extending or replacing their local field-bus technology with Ethernet and IP-based solutions. Examples of this evolution include CIP EtherNet/IP, Modbus/TCP, Foundation Fieldbus HSE, PROFINet and Invensys/Foxboro FOXnet. At the same time, wireless, low power field devices are being introduced that facilitate a significant increase in the amount of information which industrial users can collect and the number of control points that can be remotely managed.

IPv6 appears as a core technology at the conjunction of both trends, as illustrated by the current [[ISA100.11a](#)] industrial Wireless Sensor Networking (WSN) specification, where layers 1-4 technologies developed for purposes other than industrial CT -- IEEE 802.15.4 PHY and MAC, 6LoWPAN and IPv6, and UDP - are adapted to industrial CT use. But due to the lack of open standards for routing in Low power and Lossy Networks (LLN), even ISA100.11a leaves the routing operation to proprietary methods.

The aim of this document is to analyze the requirements from the industrial environment for a routing protocol in Low power and Lossy Networks (LLN) based on IP version 6 to power the next generation of Control Technology.

2. Terminology

This document employs terminology defined in the ROLL terminology document [[I-D.ietf-roll-terminology](#)]. This document also refers to industrial standards:

HART: "Highway Addressable Remote Transducer", a group of specifications for industrial process and control devices administered by the HART Foundation (see [[HART](#)]). The latest version for the specifications is HART7 which includes the additions for

Pister, et al.

Expires October 22, 2009

[Page 3]

Internet-Draft

roll-indus-routing-reqs

April 2009

WirelessHART.

ISA: "International Society of Automation". ISA is an ANSI accredited standards-making society. ISA100 is an ISA committee whose charter includes defining a family of standards for industrial automation. [[ISA100.11a](#)] is a working group within ISA100 that is working on a standard for monitoring and non-critical process control applications.

3. Overview

Wireless, low-power field devices enable industrial users to significantly increase the amount of information collected and the number of control points that can be remotely managed. The deployment of these wireless devices will significantly improve the productivity and safety of the plants while increasing the efficiency of the plant workers. IPv6 is perceived as a key technology to provide the scalability and interoperability that are required in that space and is being more and more present in standards and products under development and early deployments.

Cable is perceived as a more proven, safer technology, and existing, operational deployments are very stable in time. For these reasons, it is not expected that wireless will replace wire in any foreseeable future; the consensus in the industrial space is rather that wireless will tremendously augment the scope and benefits of automation by enabling the control of devices that were not connected in the past for reasons of cost and/or deployment complexities. But for LLN to

be adopted in the industrial environment, the wireless network needs to have three qualities: low power, high reliability, and easy installation and maintenance. The routing protocol used for low power and lossy networks (LLN) is important to fulfilling these goals.

Industrial automation is segmented into two distinct application spaces, known as "process" or "process control" and "discrete manufacturing" or "factory automation". In industrial process control, the product is typically a fluid (oil, gas, chemicals ...). In factory automation or discrete manufacturing, the products are individual elements (screws, cars, dolls). While there is some overlap of products and systems between these two segments, they are surprisingly separate communities. The specifications targeting industrial process control tend to have more tolerance for network latency than what is needed for factory automation.

Irrespective of this different 'process' and 'discrete' plant nature both plant types will have similar needs for automating the

collection of data that used to be collected manually, or was not collected before. Examples are wireless sensors that report the state of a fuse, report the state of a luminary, HVAC status, report vibration levels on pumps, report man-down, and so on.

Other novel application arenas that equally apply to both 'process' and 'discrete' involve mobile sensors that roam in and out of plants, such as active sensor tags on containers or vehicles.

Some if not all of these applications will need to be served by the same low power and lossy wireless network technology. This may mean several disconnected, autonomous LLN networks connecting to multiple hosts, but sharing the same ether. Interconnecting such networks, if only to supervise channel and priority allocations, or to fully synchronize, or to share path capacity within a set of physical network components may be desired, or may not be desired for practical reasons, such as e.g. cyber security concerns in relation to plant safety and integrity.

All application spaces desire battery operated networks of hundreds of sensors and actuators communicating with LLN access points. In an oil refinery, the total number of devices might exceed one million,

but the devices will be clustered into smaller networks that in most cases interconnect and report to an existing plant network infrastructure.

Existing wired sensor networks in this space typically use communication protocols with low data rates, from 1,200 baud (e.g. wired HART) to the one to two hundred Kbps range for most of the others. The existing protocols are often master/slave with command/response.

3.1. Applications and Traffic Patterns

The industrial market classifies process applications into three broad categories and six classes.

- o Safety
 - * Class 0: Emergency action - Always a critical function
- o Control
 - * Class 1: Closed loop regulatory control - Often a critical function
 - * Class 2: Closed loop supervisory control - Usually non-critical function

- * Class 3: Open loop control - Operator takes action and controls the actuator (human in the loop)
- o Monitoring
 - * Class 4: Alerting - Short-term operational effect (for example event-based maintenance)
 - * Class 5: Logging and downloading / uploading - No immediate operational consequence (e.g., history collection, sequence-of-events, preventive maintenance)

Safety critical functions effect the basic safety integrity of the plant. These normally dormant functions kick in only when process control systems, or their operators, have failed. By design and by

regular interval inspection, they have a well-understood probability of failure on demand in the range of typically once per 10-1000 years.

In-time deliveries of messages becomes more relevant as the class number decreases.

Note that for a control application, the jitter is just as important as latency and has a potential of destabilizing control algorithms.

Industrial users are interested in deploying wireless networks for the monitoring classes 4 and 5, and in the non-critical portions of classes 3 through 2.

Classes 4 and 5 also include asset monitoring and tracking which include equipment monitoring and are essentially separate from process monitoring. An example of equipment monitoring is the recording of motor vibrations to detect bearing wear. However, similar sensors detecting excessive vibration levels could be used as safeguarding loops that immediately initiate a trip, and thus end up being class 0.

In the near future, most LLN systems in industrial automation environments will be for low frequency data collection. Packets containing samples will be generated continuously, and 90% of the market is covered by packet rates of between 1/s and 1/hour, with the average under 1/min. In industrial process, these sensors include temperature, pressure, fluid flow, tank level, and corrosion. Some sensors are bursty, such as vibration monitors that may generate and transmit tens of kilo-bytes (hundreds to thousands of packets) of time-series data at reporting rates of minutes to days.

Almost all of these sensors will have built-in microprocessors that

may detect alarm conditions. Time-critical alarm packets are expected to be granted a lower latency than periodic sensor data streams.

Some devices will transmit a log file every day, again with typically tens of Kbytes of data. For these applications there is very little "downstream" traffic coming from the LLN access point and traveling to particular sensors. During diagnostics, however, a technician may

be investigating a fault from a control room and expect to have "low" latency (human tolerable) in a command/response mode.

Low-rate control, often with a "human in the loop" (also referred to as "open loop"), is implemented via communication to a control room because that's where the human in the loop will be. The sensor data makes its way through the LLN access point to the centralized controller where it is processed, the operator sees the information and takes action, and the control information is then sent out to the actuator node in the network.

In the future, it is envisioned that some open loop processes will be automated (closed loop) and packets will flow over local loops and not involve the LLN access point. These closed loop controls for non-critical applications will be implemented on LLNs. Non-critical closed loop applications have a latency requirement that can be as low as 100 ms but many control loops are tolerant of latencies above 1 s.

More likely though is that loops will be closed in the field entirely, and in such a case, having wireless links within the control loop does not usually present actual value. Most control loops have sensors and actuators within such proximity that a wire between them remains the most sensible option from an economic point of view. This 'control in the field' architecture is already common practice with wired field busses. An 'upstream' wireless link would only be used to influence the in-field controller settings, and to occasionally capture diagnostics. Even though the link back to a control room might be a wireless, this architecture reduces the tight latency and availability requirements for the wireless links.

Closing loops in the field:

- o does not prevent the same loop from being closed through a remote multi-variable controller during some modes of operation, while being closed directly in the field during other modes of operation (e.g., fallback, or when timing is more critical)
- o does not imply that the loop will be closed with a wired connection, or that the wired connection is more energy efficient

even when it exists as an alternate to the wireless connection.

A realistic future scenario is for a field device with a battery or ultra-capacitor power storage to have both wireless and unpowered wired communications capability (e.g., galvanically isolated RS-485), where the wireless communication is more flexible and, for local loop operation, more energy efficient, and the wired communication capability serves as a backup interconnect among the loop elements, but without a wired connection back to the operations center blockhouse. In other words, the loop elements are interconnected through wiring to a nearby junction box, but the 2 km home-run link from the junction box to the control center does not exist.

When wireless communication conditions are good, devices use wireless for loop interconnect, and either one wireless device reports alarms and other status to the control center for all elements of the loop or each element reports independently. When wireless communications are sporadic, the loop interconnect uses the self-powered galvanically-isolated RS-485 link and one of the devices with good wireless communications to the control center serves as a router for those devices which are unable to contact the control center directly.

The above approach is particularly attractive for large storage tanks in tank farms, where devices may not all have good wireless visibility of the control center, and where a home run cable from the tank to the control center is undesirable due to the electro-potential differences between the tank location and the distant control center that arise during lightning storms.

In fast control, tens of milliseconds of latency is typical. In many of these systems, if a packet does not arrive within the specified interval, the system enters an emergency shutdown state, often with substantial financial repercussions. For a one-second control loop in a system with a mean-time between shutdowns target of 30 years, the latency requirement implies nine 9s of reliability. Given such exposure, given the intrinsic vulnerability of wireless link availability, and given the emergence of control in the field architectures, most users tend not to aim for fast closed loop control with wireless links within that fast loop.

[3.2.](#) Network Topology of Industrial Applications

Although network topology is difficult to generalize, the majority of existing applications can be met by networks of 10 to 200 field devices and maximum number of hops of twenty. It is assumed that the field devices themselves will provide routing capability for the network, and additional repeaters/routers will not be required in

most cases.

For the vast majority of industrial applications, the traffic is mostly composed of real time publish/subscribe sensor data also referred to as buffered, from the field devices over a LLN towards one or more sinks. Increasingly over time, these sinks will be a part of a backbone but today they are often fragmented and isolated.

The wireless sensor network is a LLN of field devices for which two logical roles are defined, the field routers and the non routing devices. It is acceptable and even probable that the repartition of the roles across the field devices change over time to balance the cost of the forwarding operation amongst the nodes.

In order to scale a control network in terms of density, one possible architecture is to deploy a backbone as a canopy that aggregates multiple smaller LLNs. The backbone is a high-speed infrastructure network that may interconnect multiple WSNs through backbone routers. Infrastructure devices can be connected to the backbone. A gateway / manager that interconnects the backbone to the plant network of the corporate network can be viewed as collapsing the backbone and the infrastructure devices into a single device that operates all the required logical roles. The backbone is likely to become an option in the industrial network.

Typically, such backbones interconnect to the 'legacy' wired plant infrastructure, the plant network, also known as the 'Process Control Domain', the PCD. These plant automation networks are domain wise segregated from the office network or office domain (OD), which in itself is typically segregated from the Internet.

Sinks for LLN sensor data reside on both the plant network PCD, the business network OD, and on the Internet. Applications close to existing plant automation, such as wired process control and monitoring systems running on fieldbusses, that require high availability and low latencies, and that are managed by 'Control and Automation' departments typically reside on the PCD. Other applications such as automated corrosion monitoring, cathodic protection voltage verification, or machine condition (vibration) monitoring where one sample per week is considered over sampling, would more likely deliver their sensor readings in the office domain. Such applications are 'owned' by e.g. maintenance departments.

Yet other applications like third party maintained luminaries, or vendor managed inventory systems, where a supplier of chemicals needs access to tank level readings at his customer's site, will be best

served with direct Internet connectivity all the way to its sensor at his customer's site. Temporary 'Babysitting sensors' deployed for

just a few days, say during startup or troubleshooting or for ad-hoc measurement campaigns for R and D purposes are other examples where Internet would be the domain where wireless sensor data shall land, and other domains such as office and plant should preferably be circumvented if quick deployment without potentially impacting plant safety integrity is required.

This multiple domain multiple applications connectivity creates a significant challenge. Many different applications will all share the same medium, the ether, within the fence, preferably sharing the same frequency bands, and preferably sharing the same protocols, preferably synchronized to optimize co-existence challenges, yet logically segregated to avoid creation of intolerable short cuts between existing wired domains.

Given this challenge, LLN networks are best to be treated as all sitting on yet another segregated domain, segregated from all other wired domains where conventional security is organized by perimeter. Moving away from the traditional perimeter security mindset means moving towards stronger end-device identity authentication, so that LLN access points can split the various wireless data streams and interconnect back to the appropriate domain pending identity and trust established by the gateways in the authenticity of message originators.

Similar considerations are to be given to how multiple applications may or may not be allowed to share routing devices and their potentially redundant bandwidth within the network. Challenges here are to balance available capacity, required latencies, expected priorities, and last but not least available (battery) energy within the routing devices.

[3.2.1.](#) The Physical Topology

There is no specific physical topology for an industrial process control network.

One extreme example is a multi-square-kilometer refinery where isolated tanks, some of them with power but most with no backbone

connectivity, compose a farm that spans over of the surface of the plant. A few hundred field devices are deployed to ensure the global coverage using a wireless self-forming self-healing mesh network that might be 5 to 10 hops across. Local feedback loops and mobile workers tend to be only one or two hops. The backbone is in the refinery proper, many hops away. Even there, powered infrastructure is also typically several hops away. In that case, hopping to/from the powered infrastructure may often be more costly than the direct route.

In the opposite extreme case, the backbone network spans all the nodes and most nodes are in direct sight of one or more backbone router. Most communication between field devices and infrastructure devices as well as field device to field device occurs across the backbone. From afar, this model resembles the WIFI ESS (Extended Service Set). But from a layer 3 perspective, the issues are the default (backbone) router selection and the routing inside the backbone whereas the radio hop towards the field device is in fact a simple local delivery.

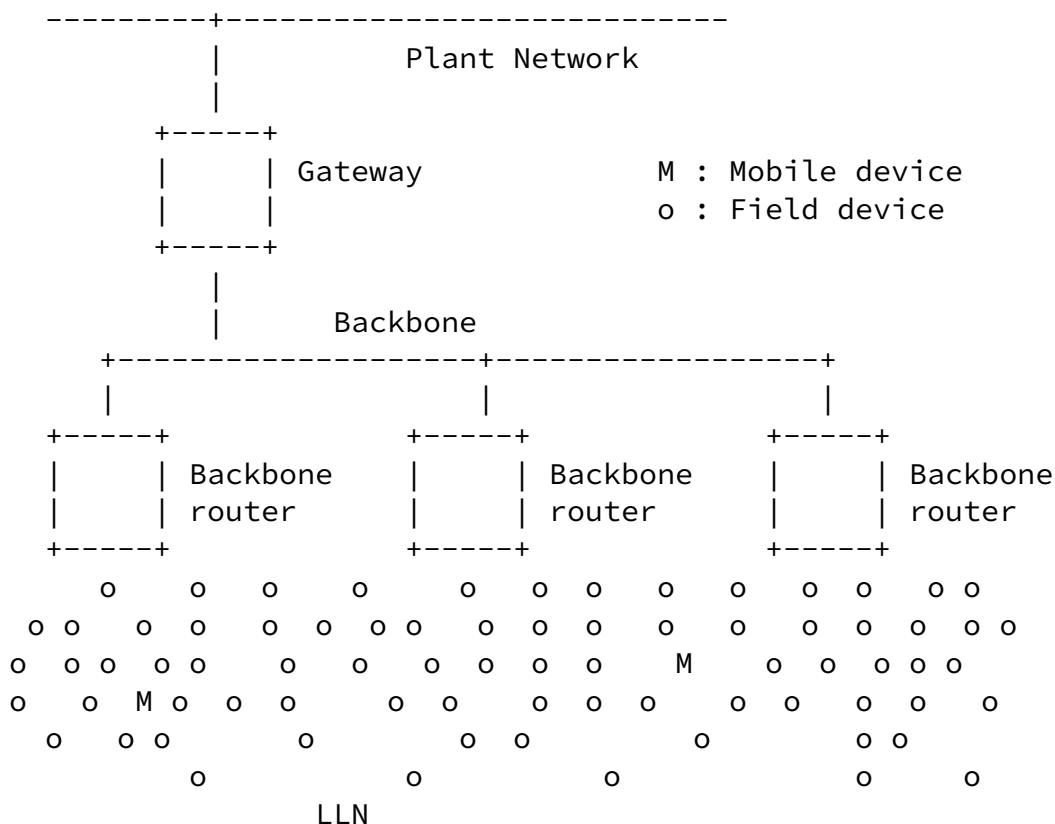

Figure 1: Backbone-based Physical Topology

An intermediate case is illustrated in Figure 1 with a backbone that spans the Wireless Sensor Network in such a fashion that any WSN node is only a few wireless hops away from the nearest Backbone Router. WSN nodes are expected to organize into self-forming self-healing self-optimizing logical topologies that enable leveraging the backbone when it is most efficient to do so.

It must be noted that the routing function is expected to be so simple that any field device could assume the role of a router, depending on the self-discovery of the topology and the power status of the neighbors. On the other hand, only devices equipped with the appropriate hardware and software combination could assume the role of an end point for a given purpose, such as sensor or actuator.

Pister, et al.

Expires October 22, 2009

[Page 11]

Internet-Draft

roll-indus-routing-reqs

April 2009

[3.2.2.](#) Logical Topologies

Most of the traffic over the LLN is publish/subscribe of sensor data from the field device towards a sink that can be a backbone router, a gateway, or a controller/manager. The destination of the sensor data is an Infrastructure devices that sits on the backbone and is reachable via one or more backbone router.

For security, reliability, availability or serviceability reasons, it is often required that the logical topologies are not physically congruent over the radio network, that is they form logical partitions of the LLN. For instance, a routing topology that is set up for control should be isolated from a topology that reports the temperature and the status of the vents, if that second topology has lesser constraints for the security policy. This isolation might be implemented as Virtual LANs and Virtual Routing Tables in shared nodes in the backbone, but correspond effectively to physical nodes in the wireless network.

Since publishing the data is the *raison d'etre* for most of the sensors, in some cases it makes sense to build proactively a set of routes between the sensors and one or more backbone router and maintain those routes at all time. Also, because of the lossy nature of the network, the routing in place should attempt to propose multiple paths in the form of Directed Acyclic Graphs oriented

towards the destination.

In contrast with the general requirement of maintaining default routes towards the sinks, the need for field device to field device connectivity is very specific and rare, though the traffic associated might be of foremost importance. Field device to field device routes are often the most critical, optimized and well-maintained routes. A class 0 control loop requires guaranteed delivery and extremely tight response times. Both the respect of criteria in the route computation and the quality of the maintenance of the route are critical for the field devices operation. Typically, a control loop will be using a dedicated direct wire that has very different capabilities, cost and constraints than the wireless medium, with the need to use a wireless path as a back up route only in case of loss of the wired path.

Considering that though each field device to field device route computation has specific constraints in terms of latency and availability it can be expected that the shortest path possible will often be selected and that this path will be routed inside the LLN as opposed to via the backbone. It can also be noted that the lifetimes of the routes might range from minutes for a mobile workers to tens of years for a command and control closed loop. Finally, time-

varying user requirements for latency and bandwidth will change the constraints on the routes, which might either trigger a constrained route recomputation, a reprovisioning of the underlying L2 protocols, or both in that order. For instance, a wireless worker may initiate a bulk transfer to configure or diagnose a field device. A level sensor device may need to perform a calibration and send a bulk file to a plant.

[4.](#) Traffic Characteristics

[ISA100.11a] selected IPv6 as its Network Layer for a number of reasons, including the huge address space and the large potential size of a subnet, which can range up to 10K nodes in a plant deployment. In the ISA100 model, industrial applications fall into four large service categories:

1. Periodic data (aka buffered). Data that is generated

periodically and has a well understood data bandwidth requirement, both deterministic and predictable. Timely delivery of such data is often the core function of a wireless sensor network and permanent resources are assigned to ensure that the required bandwidth stays available. Buffered data usually exhibits a short time to live, and the newer reading obsoletes the previous. In some cases, alarms are low priority information that gets repeated over and over. The end-to-end latency of this data is not as important as the regularity with which the data is presented to the plant application.

2. Event data. This category includes alarms and aperiodic data reports with bursty data bandwidth requirements. In certain cases, alarms are critical and require a priority service from the network.
3. Client/Server. Many industrial applications are based on a client/server model and implement a command response protocol. The data bandwidth required is often bursty. The acceptable round-trip latency for some legacy systems was based on the time to send tens of bytes over a 1200 baud link. Hundreds of milliseconds is typical. This type of request is statistically multiplexed over the LLN and cost-based fair-share best-effort service is usually expected.
4. Bulk transfer. Bulk transfers involve the transmission of blocks of data in multiple packets where temporary resources are assigned to meet a transaction time constraint. Transient resources are assigned for a limited time (related to file size and data rate) to meet the bulk transfers service requirements.

[4.1.](#) Service Parameters

The following service parameters can affect routing decisions in a resource-constrained network:

- o Data bandwidth - the bandwidth might be allocated permanently or for a period of time to a specific flow that usually exhibits well defined properties of burstiness and throughput. Some bandwidth will also be statistically shared between flows in a best effort fashion.

- o Latency - the time taken for the data to transit the network from the source to the destination. This may be expressed in terms of a deadline for delivery. Most monitoring latencies will be in seconds to minutes.
- o Transmission phase - process applications can be synchronized to wall clock time and require coordinated transmissions. A common coordination frequency is 4 Hz (250 ms).
- o Service contract type - revocation priority. LLNs have limited network resources that can vary with time. This means the system can become fully subscribed or even over subscribed. System policies determine how resources are allocated when resources are over subscribed. The choices are blocking and graceful degradation.
- o Transmission priority - the means by which limited resources within field devices are allocated across multiple services. For transmissions, a device has to select which packet in its queue will be sent at the next transmission opportunity. Packet priority is used as one criterion for selecting the next packet. For reception, a device has to decide how to store a received packet. The field devices are memory constrained and receive buffers may become full. Packet priority is used to select which packets are stored or discarded.

The routing protocol MUST also support different metric types for each link used to compute the path according to some objective function (e.g. minimize latency) depending on the nature of the traffic.

For these reasons, the ROLL routing infrastructure is required to compute and update constrained routes on demand, and it can be expected that this model will become more prevalent for field device to field device connectivity as well as for some field device to Infrastructure devices over time.

Industrial application data flows between field devices are not necessarily symmetric. In particular, asymmetrical cost and unidirectional routes are common for published data and alerts, which represent the most part of the sensor traffic. The routing protocol

MUST be able to compute a set of unidirectional routes with potentially different costs that are composed of one or more non-congruent paths.

As multiple paths are set up and a variety of flows traverse the network towards a same destination, for instance a node acting as a sink for the LLN, the use of an additional marking/tagging mechanism based on an upper layer information will be required for intermediate routers to discriminate the flows and perform the appropriate routing decision using only the content of the IPv6 packet (e.g. use of DSCP, Flow Label).

[4.2.](#) Configurable Application Requirement

Time-varying user requirements for latency and bandwidth may require changes in the provisioning of the underlying L2 protocols. A technician may initiate a query/response session or bulk transfer to diagnose or configure a field device. A level sensor device may need to perform a calibration and send a bulk file to a plant. The routing protocol MUST route on paths that are changed to appropriately provision the application requirements. The routing protocol MUST support the ability to recompute paths based on Network Layer abstractions of the underlying link attributes/metric that may change dynamically.

[4.3.](#) Different Routes for Different Flows

Because different services categories have different service requirements, it is often desirable to have different routes for different data flows between the same two endpoints. For example, alarm or periodic data from A to Z may require path diversity with specific latency and reliability. A file transfer between A and Z may not need path diversity. The routing algorithm MUST be able to generate different routes with different characteristics (e.g. Optimized according to different cost, etc...).

[5.](#) Reliability Requirements

LLN reliability constitutes several unrelated aspects:

- 1) Availability of source to destination connectivity when the application needs it, expressed in number of successes / number of attempts
- 2) Availability of source to destination connectivity when the application might need it, expressed in number of potential failures / available bandwidth,
- 3) Ability, expressed in number of successes divided by number of attempts to get data delivered from source to destination within a capped time,
- 4) How well a network (serving many applications) achieves end-to-end delivery of packets within a bounded latency
- 5) Trustworthiness of data that is delivered to the sinks.
- 6) and others depending on the specific case...

This makes quantifying reliability the equivalent of plotting it on a three plus dimensional graph. Different applications have different requirements, and expressing reliability as a one dimensional parameter, like 'reliability my wireless network is 99.9%' is often creating more confusion than clarity.

The impact of not receiving sensor data due to sporadic network outages can be devastating if this happens unnoticed. However, if destinations that expect periodic sensor data or alarm status updates, fail to get them, then automatically these systems can take appropriate actions that prevent dangerous situations. Pending the wireless application, appropriate action ranges from initiating a shut down within 100 ms, to using a last known good value for as much as N successive samples, to sending out an operator into the plant to collect monthly data in the conventional way, i.e. some portable sensor, paper and a clipboard.

The impact of receiving corrupted data, and not being able to detect that received data is corrupt, is often more dangerous. Data corruption can either come from random bit errors due to white noise, or from occasional bursty interference sources like thunderstorms or leaky microwave ovens, but also from conscious attacks by adversaries.

Another critical aspect for the routing is the capability to ensure maximum disruption time and route maintainance. The maximum disruption time is the time it takes at most for a specific path to be restored when broken. Route maintainance ensures that a path is

monitored to be restored when broken within the maximum disruption

time. Maintenance should also ensure that a path continues to provide the service for which it was established for instance in terms of bandwidth, jitter and latency.

In industrial applications, availability is usually defined with respect to end-to-end delivery of packets within a bounded latency. availability requirements vary over many orders of magnitude. Some non-critical monitoring applications may tolerate a availability of less than 90% with hours of latency. Most industrial standards, such as HART7, have set user availability expectations at 99.9%. Regulatory requirements are a driver for some industrial applications. Regulatory monitoring requires high data integrity because lost data is assumed to be out of compliance and subject to fines. This can drive up either availability, or trustworthiness requirements.

Because LLN link stability is often low, path diversity is critical. Hop-by-hop link diversity is used to improve latency-bounded reliability by sending data over diverse paths.

Because data from field devices are aggregated and funneled at the LLN access point before they are routed to plant applications, LLN access point redundancy is an important factor in overall availability. A route that connects a field device to a plant application may have multiple paths that go through more than one LLN access point. The routing protocol MUST be able to compute paths of not-necessarily-equal cost toward a given destination so as to enable load balancing across a variety of paths. The availability of each path in a multipath route can change over time. Hence, it is important to measure the availability on a per-path basis and select a path (or paths) according to the availability requirements.

6. Device-Aware Routing Requirements

Wireless LLN nodes in industrial environments are powered by a variety of sources. Battery operated devices with lifetime requirements of at least five years are the most common. Battery operated devices have a cap on their total energy, and typically can report an estimate of remaining energy, and typically do not have

constraints on the short-term average power consumption. Energy scavenging devices are more complex. These systems contain both a power scavenging device (such as solar, vibration, or temperature difference) and an energy storage device, such as a rechargeable battery or a capacitor. These systems, therefore, have limits on both long-term average power consumption (which cannot exceed the average scavenged power over the same interval) as well as the short-term limits imposed by the energy storage requirements. For solar-

powered systems, the energy storage system is generally designed to provide days of power in the absence of sunlight. Many industrial sensors run off of a 4-20 mA current loop, and can scavenge on the order of milliwatts from that source. Vibration monitoring systems are a natural choice for vibration scavenging, which typically only provides tens or hundreds of microwatts. Due to industrial temperature ranges and desired lifetimes, the choices of energy storage devices can be limited, and the resulting stored energy is often comparable to the energy cost of sending or receiving a packet rather than the energy of operating the node for several days. And of course, some nodes will be line-powered.

Example 1: solar panel, lead-acid battery sized for two weeks of rain.

Example 2: vibration scavenger, 1mF tantalum capacitor.

Field devices have limited resources. Low-power, low-cost devices have limited memory for storing route information. Typical field devices will have a finite number of routes they can support for their embedded sensor/actuator application and for forwarding other devices packets in a mesh network slotted-link.

Users may strongly prefer that the same device have different lifetime requirements in different locations. A sensor monitoring a non-critical parameter in an easily accessed location may have a lifetime requirement that is shorter and tolerate more statistical variation than a mission-critical sensor in a hard-to-reach place that requires a plant shutdown in order to replace.

The routing algorithm MUST support node-constrained routing (e.g. taking into account the existing energy state as a node constraint). Node constraints include power and memory, as well as constraints

placed on the device by the user, such as battery life.

7. Broadcast/Multicast

Some existing industrial plant applications do not use broadcast or multicast addressing to communicate to field devices. Unicast address support is sufficient for them.

In some other industrial process automation environments, multicast over IP is used to deliver to multiple nodes that may be functionally-similar or not. Example usages are:

Pister, et al.

Expires October 22, 2009

[Page 18]

Internet-Draft

roll-indus-routing-reqs

April 2009

- 1) Delivery of alerts to multiple similar servers in an automation control room. Alerts are multicast to a group address based on the part of the automation process where the alerts arose (e.g., the multicast address "all-nodes-interested-in-alerts-for-process-unit-X"). This is always a restricted-scope multicast, not a broadcast
- 2) Delivery of common packets to multiple routers over a backbone, where the packets results in each receiving router initiating multicast (sometimes as a full broadcast) within the LLN. For instance, This can be a byproduct of having potentially physically separated backbone routers that can inject messages into different portions of the same larger LLN.
- 3) Publication of measurement data to more than one subscriber. This feature is useful in some peer to peer control applications. For example, level position may be useful to a controller that operates the flow valve and also to the overflow alarm indicator. Both controller and alarm indicator would receive the same publication sent as a multicast by the level gauge.

Both of these uses require an 1:N security mechanism as well; they aren't of any use if the end-to-end security is only point-to-point.

It is quite possible that first-generation wireless automation field networks can be adequately useful without either of these

capabilities, but in the near future, wireless field devices with communication controllers and protocol stacks will require control and configuration, such as firmware downloading, that may benefit from broadcast or multicast addressing.

The routing protocol SHOULD support broadcast or multicast addressing.

8. Route Establishment Time

During network formation, installers with no networking skill must be able to determine if their devices are "in the network" with sufficient connectivity to perform their function. Installers will have sufficient skill to provision the devices with a sample rate or activity profile. The routing algorithm MUST find the appropriate route(s) and report success or failure within several minutes, and SHOULD report success or failure within tens of seconds.

Network connectivity in real deployments is always time varying, with time constants from seconds to months. So long as the underlying connectivity has not been compromised, this link churn should not

substantially affect network operation. The routing algorithm MUST respond to normal link failure rates with routes that meet the Service requirements (especially latency) throughout the routing response. The routing algorithm SHOULD always be in the process of recalculating the route in response to changing link statistics. The routing algorithm MUST recalculate the paths when field devices change due to insertion, removal or failure, and this recalculation MUST NOT cause latencies greater than the specified constraints (typically seconds to minutes).

9. Mobility

Various economic factors have contributed to a reduction of trained workers in the plant. The industry as a whole appears to be trying to solve this problem with what is called the "wireless worker". Carrying a PDA or something similar, this worker will be able to accomplish more work in less time than the older, better-trained workers that he or she replaces. Whether the premise is valid, the

use case is commonly presented: the worker will be wirelessly connected to the plant IT system to download documentation, instructions, etc., and will need to be able to connect "directly" to the sensors and control points in or near the equipment on which he or she is working. It is possible that this "direct" connection could come via the normal LLNs data collection network. This connection is likely to require higher bandwidth and lower latency than the normal data collection operation.

PDA's are typically used as the user interfaces for plant historians, asset management systems, and the likes. Undecided yet is if these PDA's will use the LLN network directly to talk to field sensors, or if they will rather use other wireless connectivity that proxys back into the field, or to anywhere else.

The routing protocol SHOULD support the wireless worker with fast network connection times of a few of seconds, and low command and response latencies to the plant behind the LLN access points, to applications, and to field devices. The routing protocol SHOULD also support the bandwidth allocation for bulk transfers between the field device and the handheld device of the wireless worker. The routing protocol SHOULD support walking speeds for maintaining network connectivity as the handheld device changes position in the wireless network.

Some field devices will be mobile. These devices may be located on moving parts such as rotating components or they may be located on vehicles such as cranes or fork lifts. The routing protocol SHOULD support vehicular speeds of up to 35 kmph.

10. Manageability

The process and control industry is manpower constrained. The aging demographics of plant personnel are causing a looming manpower problem for industry across many markets. The goal for the industrial networks is to have the installation process not require any new skills for the plant personnel. The person would install the wireless sensor or wireless actuator the same way the wired sensor or wired actuator is installed, except the step to connect wire is eliminated.

Most users in fact demand even much further simplified provisioning

methods, whereby automatically any new device will connect and report at the LLN access point. This requires availability of open and untrusted side channels for new joiners, and it requires strong and automated authentication so that networks can automatically accept or reject new joiners. Ideally, for a user, adding new devices should be as easy as dragging and dropping an icon from a pool of authenticated new joiners into a pool for the wired domain that this new sensor should connect to. Under the hood, invisible to the user, auditable security mechanisms should take care of new device authentication, and secret join key distribution. These more sophisticated 'over the air' secure provisioning methods should eliminate the use of traditional configuration tools for setting up devices prior to being ready to securely join a LLN access point.

There will be many new applications where even without any human intervention at the plant, devices that have never been on site before, should be allowed, based on their credentials and crypto capabilities, to connect anyway. Examples are 3rd party road tankers, rail cargo containers with overfill protection sensors, or consumer cars that need to be refueled with hydrogen by robots at future petrol stations.

The routing protocol for LLNs is expected to be easy to deploy and manage. Because the number of field devices in a network is large, provisioning the devices manually may not make sense. The routing MAY require commissioning of information about the node itself, like identity, security tokens, radio standards and frequencies, etc. The routing protocol SHOULD NOT require to preprovision information about the environment where the node will be deployed. The routing protocol MUST enable the full discovery and setup of the environment (available links, selected peers, reachable network).The protocol also MUST support the distribution of configuration from a centralized management controller if operator-initiated configuration change is allowed.

[11](#). Security

Given that wireless sensor networks in industrial automation operate in systems that have substantial financial and human safety implications, security is of considerable concern. Levels of

security violation that are tolerated as a "cost of doing business" in the banking industry are not acceptable when in some cases literally thousands of lives may be at risk.

Security is easily confused with guarantee for availability. When discussing wireless security, it's important to distinguish clearly between the risks of temporarily losing connectivity, say due to a thunderstorm, and the risks associated with knowledgeable adversaries attacking a wireless system. The conscious attacks need to be split between 1) attacks on the actual application served by the wireless devices and 2) attacks that exploit the presence of a wireless access point that may provide connectivity onto legacy wired plant networks, so attacks that have little to do with the wireless devices in the LLNs. The second type of attack, access points that might be wireless backdoors that may allow an attacker outside the fence to access typically non-secured process control and/or office networks, are typically the ones that do create exposures where lives are at risk. This implies that the LLN access point on its own must possess functionality that guarantees domain segregation, and thus prohibits many types of traffic further upstream.

Current generation industrial wireless device manufactures are specifying security at the MAC layer and the transport layer. A shared key is used to authenticate messages at the MAC layer. At the transport layer, commands are encrypted with unique randomly-generated end-to-end Session keys. HART7 and ISA100.11a are examples of security systems for industrial wireless networks.

Although such symmetric key encryption and authentication mechanisms at MAC and transport layers may protect reasonably well during the lifecycle, the initial network boot (provisioning) step in many cases requires more sophisticated steps to securely land the initial secret keys in field devices. It is vital that also during these steps, the ease of deployment and the freedom of mixing and matching products from different suppliers does not complicate life for those that deploy and commission. Given average skill levels in the field, and given serious resource constraints in the market, investing a little bit more in sensor node hardware and software so that new devices automatically can be deemed trustworthy, and thus automatically join the domains that they should join, with just one drag and drop action for those in charge of deploying, will yield in faster adoption and proliferation of the LLN technology.

Industrial plants may not maintain the same level of physical security for field devices that is associated with traditional network sites such as locked IT centers. In industrial plants it must be assumed that the field devices have marginal physical security and might be compromised. The routing protocol SHOULD limit the risk incurred by one node being compromised, for instance by proposing non congruent path for a given route and balancing the traffic across the network.

The routing protocol SHOULD compartmentalize the trust placed in field devices so that a compromised field device does not destroy the security of the whole network. The routing MUST be configured and managed using secure messages and protocols that prevent outsider attacks and limit insider attacks from field devices installed in insecure locations in the plant.

The wireless environment typically forces the abandonment of classical 'by perimeter' thinking when trying to secure network domains. Wireless nodes in LLN networks should thus be regarded as little islands with trusted kernels, situated in an ocean of untrusted connectivity, an ocean that might be full of pirate ships. Consequently, confidence in node identity and ability to challenge authenticity of source node credentials gets more relevant. Cryptographic boundaries inside devices that clearly demark the border between trusted and untrusted areas need to be drawn. Protection against compromise of the cryptographic boundaries inside the hardware of devices is outside of the scope this document.

Note that because nodes are usually expected to be capable of routing, the end node security requirements are usually a superset of the router requirements, in order to prevent a end node from being used to inject forged information into the network that could alter the plant operations.

Additional details of security across all application scenarios are provided in the ROLL security Framework [[I-D.tsao-roll-security-framework](#)].

12. IANA Considerations

This document includes no request to IANA.

13. Acknowledgements

Many thanks to Rick Enns, Alexander Chernoguzov and Chol Su Kang for their contributions.

Internet-Draft

roll-indus-routing-reqs

April 2009

14. References

14.1. Normative References

[RFC2119] Bradner, S., "Key words for use in RFCs to Indicate Requirement Levels", [BCP 14](#), [RFC 2119](#), March 1997.

14.2. Informative References

[I-D.ietf-roll-terminology]

Vasseur, J., "Terminology in Low power And Lossy Networks", [draft-ietf-roll-terminology-00](#) (work in progress), October 2008.

[I-D.tsao-roll-security-framework]

Tsao, T., Alexander, R., Dohler, M., Daza, V., and A. Lozano, "A Security Framework for Routing over Low Power and Lossy Networks", [draft-tsao-roll-security-framework-00](#) (work in progress), February 2009.

14.3. External Informative References

[HART] www.hartcomm.org, "Highway Addressable Remote Transducer", a group of specifications for industrial process and control devices administered by the HART Foundation".

[ISA100.11a]

ISA, "ISA100, Wireless Systems for Automation", May 2008, < <http://www.isa.org/Community/SP100WirelessSystemsforAutomation>>.

Authors' Addresses

Kris Pister (editor)
Dust Networks
30695 Huntwood Ave.
Hayward, 94544
USA

Email: kpister@dustnetworks.com

Internet-Draft

roll-indus-routing-reqs

April 2009

Pascal Thubert (editor)
Cisco Systems
Village d'Entreprises Green Side
400, Avenue de Roumanille
Batiment T3
Biot - Sophia Antipolis 06410
FRANCE

Phone: +33 497 23 26 34
Email: pthubert@cisco.com

Sicco Dwars
Shell Global Solutions International B.V.
Sir Winston Churchilllaan 299
Rijswijk 2288 DC
Netherlands

Phone: +31 70 447 2660
Email: sicco.dwars@shell.com

Tom Phinney
5012 W. Torrey Pines Circle
Glendale, AZ 85308-3221
USA

Phone: +1 602 938 3163
Email: tom.phinney@cox.net

