

Network Working Group  
Internet-Draft  
Expires: August 5, 2006

A. Atlas, Ed.  
Google, Inc.  
A. Zinin, Ed.  
Alcatel  
February 2006

Basic Specification for IP Fast-Reroute: Loop-free Alternates  
draft-ietf-rtgwg-ipfrr-spec-base-05

Status of this Memo

By submitting this Internet-Draft, each author represents that any applicable patent or other IPR claims of which he or she is aware have been or will be disclosed, and any of which he or she becomes aware will be disclosed, in accordance with [Section 6 of BCP 79](#).

Internet-Drafts are working documents of the Internet Engineering Task Force (IETF), its areas, and its working groups. Note that other groups may also distribute working documents as Internet-Drafts.

Internet-Drafts are draft documents valid for a maximum of six months and may be updated, replaced, or obsoleted by other documents at any time. It is inappropriate to use Internet-Drafts as reference material or to cite them other than as "work in progress."

The list of current Internet-Drafts can be accessed at <http://www.ietf.org/ietf/lid-abstracts.txt>.

The list of Internet-Draft Shadow Directories can be accessed at <http://www.ietf.org/shadow.html>.

This Internet-Draft will expire on August 5, 2006.

Copyright Notice

Copyright (C) The Internet Society (2006).

Abstract

This document describes the use of loop-free alternates to provide local protection for unicast traffic in pure IP and MPLS/LDP networks in the event of a single failure, whether link, node or shared risk link group (SRLG). The goal of this technology is to reduce the micro-looping and packet loss that happens while routers converge after a topology change due to a failure. Rapid failure repair is achieved through use of precalculated backup next-hops that are loop-

Internet-Draft

[draft-ietf-rtgwg-ipfrr-spec-base-05](#)

February 2006

free and safe to use until the distributed network convergence process completes.

## Table of Contents

<a href="#">1.</a>	Introduction . . . . .	<a href="#">3</a>
<a href="#">1.1</a>	Failure Scenarios . . . . .	<a href="#">5</a>
<a href="#">2.</a>	Applicability of Described Mechanisms . . . . .	<a href="#">6</a>
<a href="#">3.</a>	Alternate Next-Hop Calculation . . . . .	<a href="#">7</a>
<a href="#">3.1</a>	Basic Loop-free Condition . . . . .	<a href="#">8</a>
<a href="#">3.2</a>	Node-Protecting Alternate Next-Hops . . . . .	<a href="#">9</a>
<a href="#">3.3</a>	Broadcast and NBMA Links . . . . .	<a href="#">9</a>
<a href="#">3.4</a>	ECMP and Alternates . . . . .	<a href="#">11</a>
<a href="#">3.5</a>	Interactions with ISIS Overload, <a href="#">RFC 3137</a> and Costed Out Links . . . . .	<a href="#">11</a>
<a href="#">3.5.1</a>	Interactions with ISIS Link Attributes . . . . .	<a href="#">12</a>
<a href="#">3.6</a>	Selection Procedure . . . . .	<a href="#">12</a>
<a href="#">4.</a>	Using an Alternate . . . . .	<a href="#">16</a>
<a href="#">4.1</a>	Terminating Use of Alternate . . . . .	<a href="#">17</a>
<a href="#">5.</a>	Requirements on LDP Mode . . . . .	<a href="#">18</a>
<a href="#">6.</a>	Routing Aspects . . . . .	<a href="#">19</a>
<a href="#">6.1</a>	Multi-Homed Prefixes . . . . .	<a href="#">19</a>
<a href="#">6.2</a>	OSPF . . . . .	<a href="#">20</a>
<a href="#">6.2.1</a>	OSPF External Routing . . . . .	<a href="#">20</a>
<a href="#">6.3</a>	BGP Next-Hop Synchronization . . . . .	<a href="#">21</a>
<a href="#">6.4</a>	Multicast Considerations . . . . .	<a href="#">21</a>
<a href="#">7.</a>	Security Considerations . . . . .	<a href="#">21</a>
<a href="#">8.</a>	IANA Considerations . . . . .	<a href="#">21</a>
<a href="#">9.</a>	References . . . . .	<a href="#">22</a>
<a href="#">9.1</a>	Normative References . . . . .	<a href="#">22</a>
<a href="#">9.2</a>	Informative References . . . . .	<a href="#">22</a>
	Authors' Addresses . . . . .	<a href="#">23</a>
<a href="#">A.</a>	OSPF Example Where LFA Based on Local Area Topology is Insufficient . . . . .	<a href="#">24</a>
	Intellectual Property and Copyright Statements . . . . .	<a href="#">26</a>



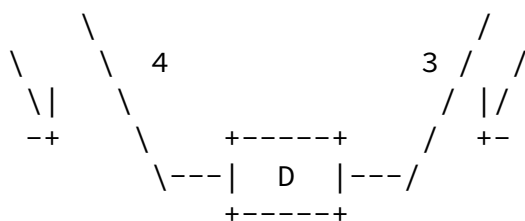

Figure 1: Basic Topology

The goal of IP Fast-Reroute is to reduce failure reaction time to 10s of milliseconds by using a pre-computed alternate next-hop, in the event that the currently selected primary next-hop fails, so that the

alternate can be rapidly used when the failure is detected. A network with this feature experiences less traffic loss and less micro-looping of packets than a network without IPFRR. There are cases where micro-looping is still a possibility since IPFRR coverage varies but in the worst possible situation a network with IPFRR is equivalent with respect to traffic convergence to a network without IPFRR.

To clarify the behavior of IP Fast-Reroute, consider the simple topology in Figure 1. When router S computes its shortest path to router D, router S determines to use the link to router E as its primary next-hop. Without IP Fast-Reroute, that link is the only next-hop that router S computes to reach D. With IP Fast-Reroute, S also looks for an alternate next-hop to use. In this example, S would determine that it could send traffic destined to D by using the link to router N\_1 and therefore S would install the link to N\_1 as its alternate next-hop. At some later time, the link between router S and router E could fail. When that link fails, S and E will be the first to detect it. On detecting the failure, S will stop sending traffic destined for D towards E via the failed link, and instead send the traffic to S's pre-computed alternate next-hop, which is the link to N\_1, until a new SPF is run and its results are installed. As with the primary next-hop, an alternate next-hop is computed for each destination. The process of computing an alternate next-hop does not alter the primary next-hop computed via a standard SPF.

If in the example of Figure 1, the link cost from N\_1 to D increased to 30 from 3, then N\_1 would not be a loop-free alternate, because the cost of the path from N\_1 to D via S would be 17 while the cost

from N\_1 directly to D would be 30. In real networks, we may often face this situation. The existence of a suitable loop-free alternate next-hop is topology dependent and the nature of the failure the alternate is calculated for.

A neighbor N can provide a loop-free alternate (LFA) if and only if

$$\text{Distance\_opt}(N, D) < \text{Distance\_opt}(N, S) + \text{Distance\_opt}(S, D)$$

Equation 1: Loop-Free Criterion

A sub-set of loop-free alternate are downstream paths which must meet a more restrictive condition that is applicable to more complex failure scenarios:

$$\text{Distance\_opt}(N, D) < \text{Distance\_opt}(S, D)$$

Equation 2: Downstream Path Criterion

## 1.1 Failure Scenarios

The alternate next-hop can protect against a single link failure, a single node failure, one or more shared risk link group failure, or a combination of these. Whenever a failure occurs that is more extensive than what the alternate was intended to protect, there is the possibility of temporarily looping traffic (note again, that such a loop would only last until the next complete SPF calculation). The example where a node fails when the alternate provided only link protection is illustrated below. If unexpected simultaneous failures occur, then micro-looping may occur since the alternates are not pre-computed to avoid the set of failed links.

If only link protection is provided and the node fails, it is possible for traffic using the alternates to experience micro-looping. This issue is illustrated in Figure 2. If Link(S->E) fails, then the link-protecting alternate via N will work correctly. However, if router E fails, then both S and N will detect a failure and switch to their alternates. In this example, that would cause S to redirect the traffic to N and N to redirect the traffic to S and thus causing a forwarding loop. Such a scenario can arise because the key assumption, that all other routers in the network are



other correlated failures (of which node failure is a specific instance). In the general case, these are handled by shared risk link groups (SRLGs) where any links in the network can belong to the SRLG. General SRLGs may add unacceptably to the computational complexity of finding a loop-free alternate.

However, a sub-category of SRLGs is of interest and can be applied only during the selection of an acceptable alternate. This sub-category is to express correlated failures of links that are connected to the same router. For example, if there are multiple logical sub-interfaces on the same physical interface, such as VLANs on an Ethernet interface, if multiple interfaces use the same physical port because of channelization, or if multiple interfaces share a correlated failure because they are on the same line-card. This sub-category of SRLGs will be referred to as local-SRLGs. A local-SRLG has all of its member links with one end connected to the same router. Thus, router S could select a loop-free alternate which does not use a link in the same local-SRLG as the primary next-hop. The local-SRLGs belonging to E can be protected against via node-protection; i.e. picking a loop-free node-protecting alternate.

Where SRLG protection is provided, it is in the context of the particular OSPF or ISIS area, whose topology is used the SPF computations to compute the loop-free alternates. If an SRLG contains links in multiple areas, then separate SRLG-protecting alternates would be required in each area that is traversed by the affected traffic.

## 2. Applicability of Described Mechanisms

IP Fast Reroute mechanisms described in this memo cover intra-domain routing only, with OSPF[RFC2328] or ISIS [[RFC1195](#)] [[RFC2966](#)] as the IGP. Specifically, Fast Reroute for BGP inter-domain routing is not

part of this specification.

Certain aspects of OSPF inter-area routing behavior explained in [Section 6.2](#) and [Appendix A](#) impact the ability of the router calculating the backup next-hops to assess traffic trajectories. In order to avoid micro-looping and ensure required coverage, certain constraints are applied to multi-area OSPF networks:

- a. Loop-free alternates should not be used in the backbone area if there are any virtual links configured unless, for each transit area, there is a full mesh of virtual links between all ABRs in that area. Loop-free alternates may be used in non-backbone areas regardless of whether there are virtual links configured.
- b. Loop-free alternates should not be used for inter-area routes in an area that contains more than one alternate ABR. [[RFC3509](#)]
- c. Loop-free alternates should not be used for AS External routes or ASBR routes in a non-backbone area of a network where there exists an ABR that is announced as an ASBR in multiple non-backbone areas and there exists another ABR that is in at least two of the same non-backbone areas.
- d. Loop-free alternates should not be used in a non-backbone area of a network for AS External routes where an AS External prefix is advertised with the same type of external metric by multiple ASBRs, which are in different non-backbone areas, with a forwarding address of 0.0.0.0 or by one or more ASBRs with forwarding addresses in multiple non-backbone areas when an ABR exists simultaneously in two or more of those non-backbone areas.

### 3. Alternate Next-Hop Calculation

In addition to the set of primary next-hops obtained through a shortest path tree (SPT) computation that is part of standard link-state routing functionality, routers supporting IP Fast Reroute also calculate a set of backup next hops that are engaged when a local failure occurs. These backup next hops are calculated to provide required type of protection (i.e. link-protecting and/or node-protecting) and to guarantee that when the expected failure occurs, forwarding traffic through them will not result in a loop. Such next hops are called loop-free alternates or LFAs throughout this specification.

In general, to be able to calculate the set of LFAs for a specific destination D, a router needs to know the following basic pieces of information:

- o Shortest-path distance from the calculating router to the



- destination ( $\text{Distance\_opt}(S, D)$ )
- o Shortest-path distance from the router's IGP neighbors to the destination ( $\text{Distance\_opt}(N, D)$ )
- o Shortest path distance from the router's IGP neighbors to itself ( $\text{Distance\_opt}(N, S)$ )
- o  $\text{Distance\_opt}(S, D)$  is normally available from the regular SPF calculation performed by the link-state routing protocols.  $\text{Distance\_opt}(N, D)$  and  $\text{Distance\_opt}(N, S)$  can be obtained by performing additional SPF calculations from the perspective of each IGP neighbor (i.e. considering the neighbor's vertex as the root of the SPT--called  $\text{SPT}(N)$  hereafter--rather than the calculating router's one, called  $\text{SPT}(S)$ ).

This specification defines a form of SRLG protection limited to those SRLGs that include a link that the calculating router is directly connected to. Information about local link SRLG membership is manually configured. Information about remote link SRLG membership is dynamically obtained using [\[RFC4205\]](#) or [\[RFC4203\]](#). In order to choose among all available LFAs that provide required SRLG protection for a given destination, the calculating router needs to track the set of SRLGs that the path through a specific IGP neighbor involves. To do so, each node  $D$  in the network topology is associated with  $\text{SRLG\_set}(N, D)$ , which is the set of SRLGs that would be crossed if traffic to  $D$  was forwarded through  $N$ . To calculate this set, the router initializes  $\text{SRLG\_set}(N, N)$  for each of its IGP neighbors to be empty. During the  $\text{SPT}(N)$  calculation, when a new vertex  $V$  is added to the SPT, its  $\text{SRLG\_set}(N, V)$  is set to the union of SRLG sets associated with its parents, and the SRLG sets associated with the links from  $V$ 's parents to  $V$ . The union of the set of SRLG associated with a candidate alternate next-hop and the  $\text{SRLG\_set}(N, D)$  for the neighbor reached via that candidate next-hop is used to determine SRLG protection.

The following sections provide information required for calculation of LFAs. Sections [Section 3.1](#) through [Section 3.4](#) define different types of LFA conditions. [Section 3.5](#) describes constraints imposed by the IS-IS overload and OSPF stub router functionality. [Section 3.6](#) defines the summarized algorithm for LFA calculation using the definitions in the previous sections.

### [3.1](#) Basic Loop-free Condition

Alternate next hops used by implementations following this specification MUST conform to at least the loop-freeness condition

stated above in Equation 1. This condition guarantees that forwarding traffic to an LFA will not result in a loop after a link failure.

Further conditions may be applied when determining link-protecting and/or node-protecting alternate next-hops as described in Sections [Section 3.2](#) and [Section 3.3](#).

### [3.2](#) Node-Protecting Alternate Next-Hops

For an alternate next-hop N to protect against node failure of a primary neighbor E for destination D, N must be loop-free with respect to both E and D. In other words, N's path to D must not go through E. This is the case if Equation 3 is true, where N is the neighbor providing a loop-free alternate.

$$\text{Distance\_opt}(N, D) < \text{Distance\_opt}(N, E) + \text{Distance\_opt}(E, D)$$

Equation 3: Criteria for a Node-Protecting Loop-Free Alternate

If  $\text{Distance\_opt}(N, D) = \text{Distance\_opt}(N, E) + \text{Distance\_opt}(E, D)$ , it is possible that N has equal-cost paths and one of those could provide protection against E's node failure. However, it is equally possible that one of N's paths goes through E, and the calculating router has no way to influence N's decision to use it. Therefore, it SHOULD be assumed that an alternate next-hop does not offer node protection if Equation 3 is not met.

### [3.3](#) Broadcast and NBMA Links

Verification of the link-protection property of a next hop in the case of a broadcast link is more elaborate than for a point-to-point link. This is because a broadcast link is represented as a pseudo-node with zero-cost links connecting it to other nodes.

Because failure of an interface attached to a broadcast segment may mean loss of connectivity of the whole segment, the condition described for broadcast link protection is pessimistic and requires that the alternate is loop-free with regard to the pseudo-node. Consider the example in Figure 3.

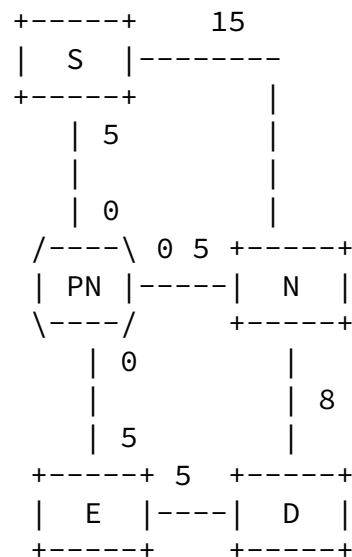

Figure 3: Loop-Free Alternate that is Link-Protecting

In Figure 3, N offers a loop-free alternate which is link-protecting. If the primary next-hop uses a broadcast link, then an alternate SHOULD be loop-free with respect to that link's pseudo-node to provide link protection. This requirement is described in Equation 4 below.

$$D_{\text{opt}}(N, D) < D_{\text{opt}}(N, \text{pseudo}) + D_{\text{opt}}(\text{pseudo}, D)$$

Equation 4: Loop-Free Link-Protecting Criterion for Broadcast Links

Because the shortest path from the pseudo-node goes through E, if a loop-free alternate from a neighbor N is node-protecting, the alternate will also be link-protecting unless the router S can only reach the alternate neighbor N via the same pseudo-node. This can occur because S will direct traffic away from the shortest path to use an alternate.

To obtain link protection, it is necessary both that the path from the selected alternate next-hop does not traverse the link of interest and that the link used from S to reach that alternate next-hop is not the link of interest. The latter can only occur with non-



link protection from L3 to E3. The third primary next-hop L3 to E3 can obtain link and node protection from L2 to E1 and from L2 to E2. It is possible for both the primary next-hop L2 to E2 and the primary next-hop L2 to E1 to obtain an alternate next-hop that provides both link and node protection by using L1.

Alternate next-hops are determined for each primary next-hop separately. As with alternate selection in the non-ECMP case, these alternate next-hops should maximize the coverage of the failure cases.

### [3.5](#) Interactions with ISIS Overload, [RFC 3137](#) and Costed Out Links

As described in [[RFC3137](#)], there are cases where it is desirable not to have a router used as a transit node. For those cases, it is also desirable not to have the router used on an alternate path.

For computing an alternate, a router MUST NOT use an alternate next-hop that is along a link whose cost or reverse cost is LSInfinity (for OSPF) or the maximum cost (for ISIS) or which has the overload bit set (for ISIS). For a broadcast link, the reverse cost associated with a potential alternate next-hop is the cost towards the pseudo-node advertised by the next-hop router. For point-to-point links, if a specific link from the next-hop router cannot be associated with a particular link, then the reverse cost considered is that of the minimum cost link from the next-hop router back to S.

In the case of OSPF, if all links from router S to a neighbor N<sub>i</sub> have a reverse cost of LSInfinity, then router S MUST NOT use N<sub>i</sub> as an alternate.

Similarly in the case of ISIS, if N<sub>i</sub> has the overload bit set, then S MUST NOT consider using N<sub>i</sub> as an alternate.

This preserves the desired behavior of diverting traffic away from a router which is following [[RFC3137](#)] and it also preserves the desired behavior when an operator sets the cost of a link to LSInfinity for maintenance which is not permitting traffic across that link unless there is no other path.

If a link or router which is costed out was the only possible alternate to protect traffic from a particular router S to a

particular destination, then there should be no alternate provided for protection.

### [3.5.1](#) Interactions with ISIS Link Attributes

[I-D.ietf-isis-link-attr] describes several flags whose interactions with LFAs needs to be defined. A router SHOULD NOT specify the "local protection available" flag as a result of having LFAs. A router SHOULD NOT use an alternate next-hop that is along a link for which the link has been advertised with the attribute "link excluded from local protection path" or with the attribute "local mainenance required".

### [3.6](#) Selection Procedure

A router supporting this specification SHOULD attempt to select at least one loop-free alternate next-hop for each primary next-hop used for a given prefix. A router MAY decide to not use an available loop-free alternate next-hop. A reason for such a decision might be that the loop-free alternate next-hop does not provide protection for the failure scenario of interest.

The alternate selection should maximize the coverage of the failure

cases.

When calculating alternate next-hops, the calculating router S applies the following rules.

1. S SHOULD select a loop-free node-protecting alternate next-hop, if one is available. If no loop-free node-protecting alternate is available, then S MAY select a loop-free link-protecting alternate.
2. If S has a choice between a loop-free link-protecting node-protecting alternate and a loop-free node-protecting alternate which is not link-protecting, S SHOULD select a loop-free node-protecting alternate which is also link-protecting. This can occur as explained in [Section 3.3](#).
3. If S has multiple primary next-hops, then S SHOULD select as a loop-free alternate either one of the other primary next-hops or

a loop-free node-protecting alternate if available. If no loop-free node-protecting alternate is available and no other primary next-hop can provide link-protection, then S SHOULD select a loop-free link-protecting alternate.

4. Implementations SHOULD support a mode where other primary next-hops satisfying the basic loop-free condition and providing at least a minimal level of protection are preferred over any non-primary alternates. This mode is provided to allow the administrator to preserve traffic patterns based on regular ECMP behavior.

Following the above rules maximizes the level of protection and use of primary (ECMP) next-hops.

Each next-hop is associated with a set of non-mutually-exclusive characteristics based on whether it is used as a primary next-hop to a particular destination D, and the type of protection it can provide relative to a specific primary next-hop E:

Primary Path - The next-hop is used by S as primary.

Loop-Free Node-Protecting Alternate - This next-hop satisfies Equation 1 and Equation 3. The path avoids S, S's primary neighbor E, and the link from S to E.

Loop-Free Link-Protecting Alternate - This next-hop satisfies Equation 1 but not Equation 3. If the primary next-hop uses a broadcast link, then this next-hop satisfies Equation 4.

An alternate path may also provide none, some or complete SRLG protection as well as node and link or link protection. For instance, a link may belong to two SRLGs G1 and G2. The alternate path might avoid other links in G1 but not G2, in which case the alternate would only provide partial SRLG protection.

Below is an algorithm that can be used to calculate loop-free alternate next-hops. The algorithm is given for informational purposes and implementations are free to use any other algorithm as long as it satisfies the rules described above.

The following procedure describes how to select an alternate next-hop. The procedure is described to determine alternate next-hops to use to reach each router in the topology. Prefixes that are advertised by a single router can use the alternate next-hop computed for the router to which they are attached. The same procedure can be used to reach a prefix that is advertised by more than one router when the logical topological transformation described in [Section 6.1](#) is used.

S is the computing router and has candidate next-hops H<sub>1</sub> through H<sub>k</sub>. N<sub>i</sub> and N<sub>j</sub> are used to refer to neighbors of S. For a next-hop to be a candidate, the next-hop must be associated with a bi-directional link, as is determined by the IGP. For a particular destination router D, let S have already computed D<sub>opt</sub>(S, D), and for each neighbor N<sub>i</sub>, D<sub>opt</sub>(N<sub>i</sub>, D), D<sub>opt</sub>(N<sub>i</sub>, S), and D<sub>opt</sub>(N<sub>i</sub>, N<sub>j</sub>), the distance from N<sub>i</sub> to each other neighbor N<sub>j</sub>, and the set of SRLGs traversed by the path D<sub>opt</sub>(N<sub>i</sub>, D). S SHOULD follow the below procedure for every primary next-hop selected to reach D. This set of primary next-hops is represented P<sub>1</sub> to P<sub>p</sub>. This procedure finds the alternate next-hop(s) for P<sub>i</sub>.

First, initialize the alternate information for P<sub>i</sub> as follows:

```
P_i.alt_next_hops = {}
P_i.alt_type = NONE P_i.alt_link-protect = FALSE
P_i.alt_node-protect = FALSE
P_i.alt_srlg-protect = {}
```

For each candidate next-hop H<sub>h</sub>,

1. Initialize variables as follows:

```
cand_type = NONE
cand_link-protect = FALSE
cand_node-protect = FALSE
cand_srlg-protect = {}
```

2. If H<sub>h</sub> is P<sub>i</sub>, skip it and continue to the next candidate next-hop.
3. If H<sub>h</sub>.link is administratively allowed to be used as an



alternate,

and the cost of H\_h.link less than the maximum,  
and the reverse cost of H\_h is less than the maximum,  
and H\_h.neighbor is not overloaded (for ISIS),  
and H\_h.link is bi-directional,

then H\_h can be considered as an alternate. Otherwise, skip it and continue to the next candidate next-hop.

4. If  $D_{opt}(H\_h.neighbor, D) \geq D_{opt}(H\_h.neighbor, S) + D_{opt}(S, D)$ , then H\_h is not loop-free. Skip it and continue to the next candidate next-hop.
5. cand\_type = LOOP-FREE.
6. If H\_h is a primary next-hop, set cand\_type to PRIMARY.
7. If H\_h.link is not P\_i.link, set can\_link-protect to TRUE.
8. If  $D_{opt}(H\_h.neighbor, D) < D_{opt}(H\_h.neighbor, P\_i.neighbor) + D_{opt}(P\_i.neighbor, D)$ , set cand\_node-protect to TRUE.
9. If the router considers SRLGs, then set the cand\_srlg-protect to the set of SRLGs traversed on the path from S via P\_i to P\_i.neighbor. Remove the set of SRLGs to which H\_h belongs from cand\_srlg-protect. Remove from cand\_srlg-protect the set of SRLGs traversed on the path from H\_h.neighbor to D. Now cand\_srlg-protect holds the set of SRLGs to which P\_i belongs and that are not traversed on the path from S via H\_h to D.
10. If cand\_type is PRIMARY, the router prefers other primary next-hops for use as the alternate, and the P\_i.alt\_type is not PRIMARY, goto Step 18.
11. If cand\_node-protect is TRUE and P\_i.alt\_node-protect is FALSE, goto Paragraph 18.
12. If cand\_link-protect is TRUE and P\_i.alt\_link-protect is FALSE, goto Step 18.
13. If cand\_srlg-protect has a better set of SRLGs than P\_i.alt\_srlg-protect, goto Step 18.

14. If `cand_srlg-protect` is different from `P_i.alt_srlg-protect`, then select between `H_h` and `P_i.alt_next_hops` based upon distance, IP addresses, or any router-local tie-breaker. If `H_h` is preferred, then goto to Step 18. Otherwise, skip `H_h` and continue to the next candidate next-hop.
15. Based upon the alternate types, the alternate distances, IP addresses, or other tie-breakers, decide if `H_h` is preferred to `P_i.alt_next_hops`. If so, goto Step 18.
16. Decide if `P_i.alt_next_hops` is preferred to `H_h`. If so, then skip `H_h` and continue to the next candidate next-hop.
17. Add `H_h` into `P_i.alt_next_hops`. Set `P_i.alt_type` to the better type of `H_h.alt_type` and `P_i.alt_type`. Continue to the next candidate next-hop.
18. Replace the `P_i` alternate next-hop set with `H_h` as follows:

```
P_i.alt_next_hops = {H_h}
P_i.alt_type = cand_type
P_i.alt_link-protect = cand_link-protect
P_i.alt_node-protect = cand_node-protect
P_i.alt_srlg-protect = cand_srlg-protect
```

Continue to the next candidate next-hop.

#### 4. Using an Alternate

If an alternate next-hop is available, the router redirects traffic to the alternate next-hop in case of a primary next-hop failure as follows.

When a next-hop failure is detected via a local interface failure or other failure detection mechanisms (see [FRAMEWORK]), the router SHOULD:

1. Remove the primary next-hop associated with the failure.
2. Install the loop-free alternate calculated for the failed next-hop if it is not already installed (e.g. the alternate is also a primary next-hop).

Note that the router MAY remove other next-hops if it believes (via SRLG analysis) that they may have been affected by the same failure, even if it is not visible at the time of failure detection.

The alternate next-hop MUST be used only for traffic types which are routed according to the shortest path. Multicast traffic is specifically out of scope for this specification.

#### 4.1 Terminating Use of Alternate

A router MUST limit the amount of time an alternate next-hop is used after the primary next-hop has become unavailable. This ensures that the router will start using the new primary next-hops. It ensures that all possible transient conditions are removed and the network converges according to the deployed routing protocol.

A router that implements [[I-D.ietf-rtgwg-microloop-analysis](#)] SHOULD follow the rules given there for terminating the use of an alternate.

It is desirable to avoid micro-forwarding loops involving S. An example illustrating the problem is given in Figure 5. If the link from S to E fails, S will use N1 as an alternate and S will compute N2 as the new primary next-hop to reach D. If S starts using N2 as soon as S can compute and install its new primary, it is probable that N2 will not have yet installed its new primary next-hop. This would cause traffic to loop and be dropped until N2 has installed the new topology. This can be avoided by S delaying its installation and leaving traffic on the alternate next-hop.

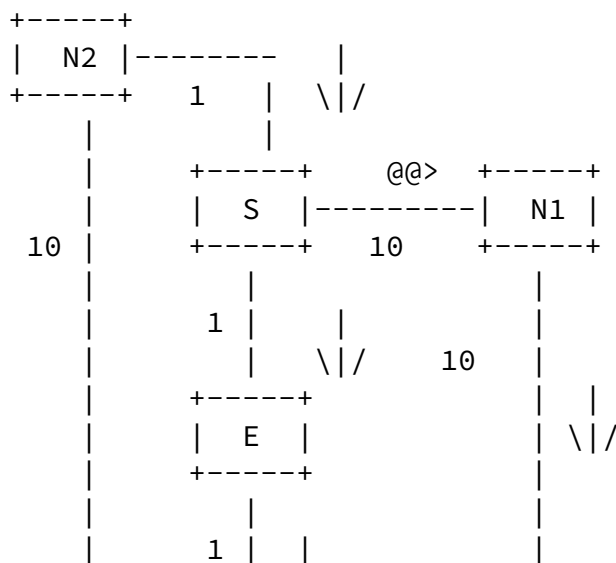

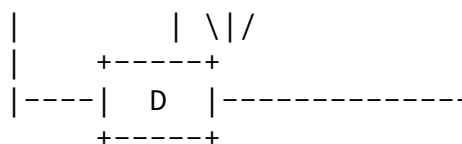

Figure 5: Example where Continued Use of Alternate is Desirable

This is an example of a case where the new primary is not a loop-free

alternate before the failure and therefore may have been forwarding traffic through S. This will occur when the path via a previously upstream node is shorter than the the path via a loop-free alternate neighbor. In these cases, it is useful to give sufficient time to ensure that the new primary neighbor and other nodes on the new primary path have switched to the new route.

If the newly selected primary was loop-free before the failure, then it is safe to switch to that new primary immediately; the new primary wasn't dependent on the failure and therefore its path will not have changed.

Given that there is an alternate providing appropriate protection and while the assumption of a single failure holds, it is safe to delay the installation of the new primaries; this will not create forwarding loops because the alternate's path to the destination is known to not go via S or the failed element and will therefore not be affected by the failure.

An implementation SHOULD continue to use the alternate next-hops for packet forwarding even after the new routing information is available based on the new network topology. The use of the alternate next-hops for packet forwarding SHOULD terminate:

- a. if the new primary next-hop was loop-free prior to the topology change, or
- b. if a configured hold-down, which represents a worst-case bound on the length of the network convergence transition, has expired, or
- c. if notification of an unrelated topological change in the network is received.

## 5. Requirements on LDP Mode

Since LDP traffic will follow the path specified by the IGP, it is also possible for the LDP traffic to follow the loop-free alternates indicated by the IGP. To do so, it is necessary for LDP to have the appropriate labels available for the alternate so that the appropriate out-segments can be installed in the forwarding plane before the failure occurs.

This means that a Label Switched Router (LSR) running LDP must distribute its labels for the FECs it can provide to all its neighbors, regardless of whether or not they are upstream. Additionally, LDP must be acting in liberal label retention mode so that the labels which correspond to neighbors that aren't currently

the primary neighbor are stored. Similarly, LDP should be in downstream unsolicited mode, so that the labels for the FEC are distributed other than along the SPT.

If these requirements are met, then LDP can use the loop-free alternates without requiring any targeted sessions or signaling extensions for this purpose.

## 6. Routing Aspects

### 6.1 Multi-Homed Prefixes

An SPF-like computation is run for each topology, which corresponds to a particular OSPF area or ISIS level. The IGP needs to determine loop-free alternates to multi-homed routes. Multi-homed routes occur for routes obtained from outside the routing domain by multiple routers, for subnets on links where the subnet is announced from multiple ends of the link, and for routes advertised by multiple routers to provide resiliency.

Figure 6 demonstrates such a topology. In this example, the shortest path to reach the prefix p is via E. The prefix p will have the link to E as its primary next-hop. If the alternate next-hop for the prefix p is simply inherited from the router advertising it on the shortest path to p, then the prefix p's alternate next-hop would be the link to C. This would provide link protection, but not the node

protection that is possible via A.

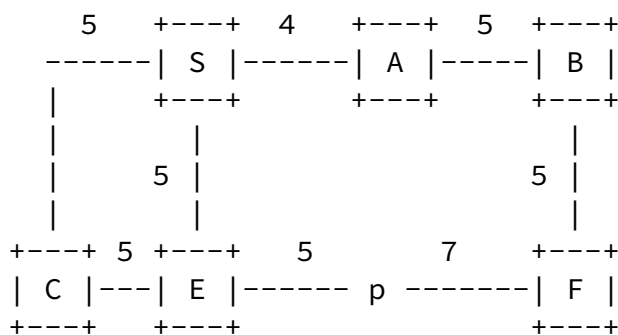

Figure 6: Multi-homed prefix

To determine the best protection possible, the prefix p can be treated in the SPF computations as a node with uni-directional links to it from those routers that have advertised the prefix. Such a node need never have its links explored, as it has no out-going links.

If there exist multiple multi-homed prefixes that share the same

connectivity and the difference in metrics to those routers, then a single node can be used to represent the set. For instance, if in Figure 6 there were another prefix X that was connected to E with a metric of 1 and to F with a metric of 3, then that prefix X could use the same alternate next-hop as was computed for prefix p.

A router SHOULD compute the alternate next-hop for an IGP multi-homed prefix by considering alternate paths via all routers that have announced that prefix.

## 6.2 OSPF

OSPF introduces certain complications because it is possible for the traffic path to exit an area and then re-enter that area. This can occur whenever a router considers the same route from multiple areas. There are several cases where issues such as this can occur. They happen when another area permits a shorter path to connect two ABRs than is available in the area where the LFA has been computed. To clarify, an example topology is given in [Appendix A](#).

- a. Virtual Links: These allow paths to leave the backbone area and traverse the transit area. The path provided via the transit area can exit via any ABR. The path taken is not the shortest path determined by doing an SPF in the backbone area.
- b. Alternate ABR[RFC3509]: When an ABR is not connected to the backbone, it considers the inter-area summaries from multiple areas. The ABR A may determine to use area 2 but that path could traverse another alternate ABR B that determines to use area 1. This can lead to scenarios similar to that illustrated in Figure 7.
- c. ASBR Summaries: An ASBR may itself be an ABR and can be announced into multiple areas. This presents other ABRs with a decision as to which area to use. This is the example illustrated in Figure 7.
- d. AS External Prefixes: A prefix may be advertised by multiple ASBRs in different areas and/or with multiple forwarding addresses that are in different areas, which are connected via at least one common ABR. This presents such ABRs with a decision as to which area to use to reach the prefix.

### [6.2.1](#) OSPF External Routing

When a forwarding address is set in an OSPF AS-external LSA, all routers in the network calculate their next-hops for the external

prefix by doing a lookup for the forwarding address in the routing table, rather than using the next-hops calculated for the ASBR. In this case, the alternate next-hops SHOULD be computed by selecting among the alternate paths to the forwarding link(s) instead of among alternate paths to the ASBR.

### [6.3](#) BGP Next-Hop Synchronization

Typically BGP prefixes are advertised with AS exit routers router-id, and AS exit routers are reached by means of IGP routes. BGP resolves its advertised next-hop to the immediate next-hop by potential recursive lookups in the routing database. IP Fast-Reroute computes

the alternate next-hops to all IGP destinations, which include alternate next-hops to the AS exit router's router-id. BGP simply inherits the alternate next-hop from IGP. The BGP decision process is unaltered; BGP continues to use the IGP optimal distance to find the nearest exit router. MBGP routes do not need to copy the alternate next hops.

It is possible to provide ASBR protection if BGP selected a set of IGP next-hops and allowed the IGP to determine the primary and alternate next-hops as if the BGP route were a multi-homed prefix. This is for future study.

#### [6.4](#) Multicast Considerations

Multicast traffic is out of scope for this specification of IP Fast-Reroute. The alternate next-hops SHOULD not be used for multi-cast RPF checks.

#### [7.](#) Security Considerations

The mechanism described in this document does not modify any routing protocol messages, and hence no new threats related to packet modifications or replay attacks are introduced. Traffic to certain destinations can be temporarily routed via next-hop routers that would not be used with the same topology change if this mechanism wasn't employed. However, these next-hop routers can be used anyway when a different topological change occurs, and hence this can't be viewed as a new security threat.

#### [8.](#) IANA Considerations

This document requires no IANA considerations.

#### [9.](#) References

##### [9.1](#) Normative References

- [RFC1195] Callon, R., "Use of OSI IS-IS for routing in TCP/IP and dual environments", [RFC 1195](#), December 1990.



- [RFC2328] Moy, J., "OSPF Version 2", STD 54, [RFC 2328](#), April 1998.
- [RFC3036] Andersson, L., Doolan, P., Feldman, N., Fredette, A., and B. Thomas, "LDP Specification", [RFC 3036](#), January 2001.

## [9.2](#) Informative References

- [I-D.ietf-isis-link-attr]  
Vasseur, J. and S. Previdi, "Definition of an IS-IS Link Attribute sub-TLV", [draft-ietf-isis-link-attr-01](#) (work in progress), May 2005.
- [I-D.ietf-rtgwg-ipfrr-framework]  
Shand, M. and S. Bryant, "IP Fast Reroute Framework", [draft-ietf-rtgwg-ipfrr-framework-05](#) (work in progress), March 2006.
- [I-D.ietf-rtgwg-microloop-analysis]  
Zinin, A., "Analysis and Minimization of Microloops in Link-state Routing Protocols", [draft-ietf-rtgwg-microloop-analysis-01](#) (work in progress), October 2005.
- [RFC2966] Li, T., Przygienda, T., and H. Smit, "Domain-wide Prefix Distribution with Two-Level IS-IS", [RFC 2966](#), October 2000.
- [RFC3137] Retana, A., Nguyen, L., White, R., Zinin, A., and D. McPherson, "OSPF Stub Router Advertisement", [RFC 3137](#), June 2001.
- [RFC3209] Awduche, D., Berger, L., Gan, D., Li, T., Srinivasan, V., and G. Swallow, "RSVP-TE: Extensions to RSVP for LSP Tunnels", [RFC 3209](#), December 2001.
- [RFC3509] Zinin, A., Lindem, A., and D. Yeung, "Alternative Implementations of OSPF Area Border Routers", [RFC 3509](#), April 2003.
- [RFC4203] Kompella, K. and Y. Rekhter, "OSPF Extensions in Support of Generalized Multi-Protocol Label Switching (GMPLS)", [RFC 4203](#), October 2005.

[RFC4205] Kompella, K. and Y. Rekhter, "Intermediate System to Intermediate System (IS-IS) Extensions in Support of Generalized Multi-Protocol Label Switching (GMPLS)", [RFC 4205](#), October 2005.

#### Authors' Addresses

Alia K. Atlas (editor)  
Google, Inc.  
1600 Amphitheatre Parkway  
Mountain View, CA 94043  
USA

Email: [akatlas@alum.mit.edu](mailto:akatlas@alum.mit.edu)

Alex Zinin (editor)  
Alcatel  
701 E Middlefield Rd.  
Mountain View, CA 94043  
USA

Email: [zinin@psg.com](mailto:zinin@psg.com)

Raveendra Torvi  
Avici Systems, Inc.  
101 Billerica Avenue  
N. Billerica, MA 01862  
USA

Phone: +1 978 964 2026  
Email: [rtorvi@avici.com](mailto:rtorvi@avici.com)

Gagan Choudhury  
AT&T  
200 Laurel Avenue, Room D5-3C21  
Middletown, NJ 07748  
USA

Phone: +1 732 420-3721  
Email: [gchoudhury@att.com](mailto:gchoudhury@att.com)

Internet-Draft

[draft-ietf-rtgwg-ipfrr-spec-base-05](#)

February 2006

Christian Martin  
iPath Technologies

Email: [chris@ipath.net](mailto:chris@ipath.net)

Brent Imhoff  
Juniper Networks  
1194 North Mathilda  
Sunnyvale, CA 94089  
USA

Phone: +1 314 378 2571  
Email: [bimhoff@planetspork.com](mailto:bimhoff@planetspork.com)

Don Fedyk  
Nortel Networks  
600 Technology Park  
Billerica, MA 01821  
USA

Phone: +1 978 288 3041  
Email: [dwfedyk@nortelnetworks.com](mailto:dwfedyk@nortelnetworks.com)

#### [Appendix A](#). OSPF Example Where LFA Based on Local Area Topology is Insufficient

This appendix provides an example scenario where the local area topology does not suffice to determine that an LFA is available. As described in [Section 6.2](#), one problem scenario is for ASBR summaries where the ASBR is available in two areas via intra-area routes and there is at least one ABR or alternate ABR that is in both areas. The following Figure 7 illustrates this case.

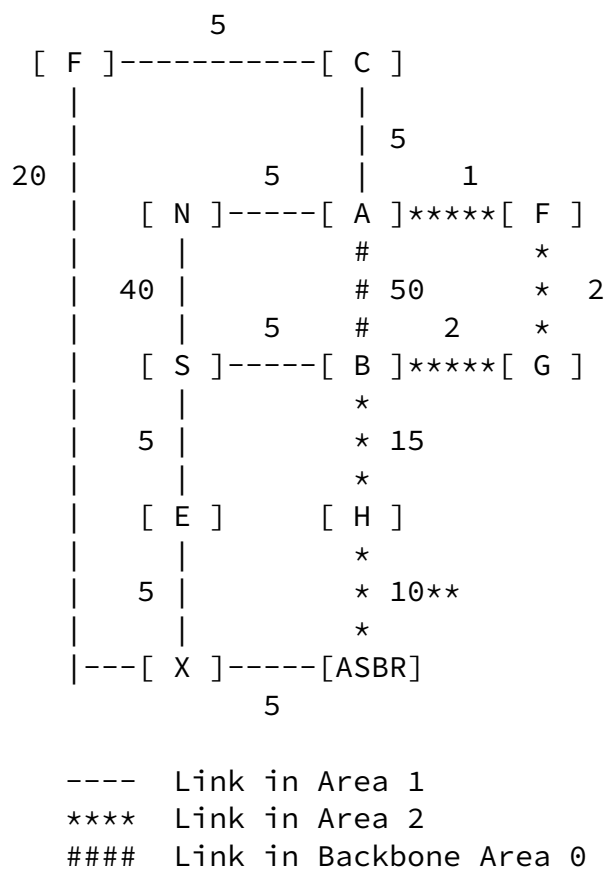

Figure 7: Topology with Multi-area ASBR Causing Area Transiting

In Figure 7, the ASBR is also an ABR and is announced into both area 1 and area 2. A and B are both ABRs that are also connected to the backbone area. S determines that N can provide a loop-free alternate to reach the ASBR. N's path goes via A. A also sees an intra-area route to ASBR via Area 2; the cost of the path in area 2 is 30, which is less than 35, the cost of the path in area 1. Therefore, A uses the path from area 2 and directs traffic to F. The path from F in area 2 goes to B. B is also an ABR and learns the ASBR from both areas 1 and area 2; B's path via area 1 is shorter (cost 20) than B's

path via area 2 (cost 25). Therefore, B uses the path from area 1 that connects to S.

Atlas, et al.

Expires August 5, 2006

[Page 25]

---

Internet-Draft

[draft-ietf-rtgwg-ipfrr-spec-base-05](#)

February 2006

#### Intellectual Property Statement

The IETF takes no position regarding the validity or scope of any Intellectual Property Rights or other rights that might be claimed to pertain to the implementation or use of the technology described in this document or the extent to which any license under such rights might or might not be available; nor does it represent that it has made any independent effort to identify any such rights. Information on the procedures with respect to rights in RFC documents can be found in [BCP 78](#) and [BCP 79](#).

Copies of IPR disclosures made to the IETF Secretariat and any assurances of licenses to be made available, or the result of an attempt made to obtain a general license or permission for the use of such proprietary rights by implementers or users of this specification can be obtained from the IETF on-line IPR repository at <http://www.ietf.org/ipr>.

The IETF invites any interested party to bring to its attention any copyrights, patents or patent applications, or other proprietary rights that may cover technology that may be required to implement this standard. Please address the information to the IETF at [ietf-ipr@ietf.org](mailto:ietf-ipr@ietf.org).

#### Disclaimer of Validity

This document and the information contained herein are provided on an

"AS IS" basis and THE CONTRIBUTOR, THE ORGANIZATION HE/SHE REPRESENTS OR IS SPONSORED BY (IF ANY), THE INTERNET SOCIETY AND THE INTERNET ENGINEERING TASK FORCE DISCLAIM ALL WARRANTIES, EXPRESS OR IMPLIED, INCLUDING BUT NOT LIMITED TO ANY WARRANTY THAT THE USE OF THE INFORMATION HEREIN WILL NOT INFRINGE ANY RIGHTS OR ANY IMPLIED WARRANTIES OF MERCHANTABILITY OR FITNESS FOR A PARTICULAR PURPOSE.

#### Copyright Statement

Copyright (C) The Internet Society (2006). This document is subject to the rights, licenses and restrictions contained in [BCP 78](#), and except as set forth therein, the authors retain all their rights.

#### Acknowledgment

Funding for the RFC Editor function is currently provided by the Internet Society.