

Service Function Chaining S.
Kumar
Internet-Draft Cisco Systems,
Inc.
Intended status: Informational M.
Tufail
Expires: January 22, 2015
Citi S.
Majee F5
Networks
Captari C.
Corporation Telstra
Homma S.
NTT
2014 July 21,

**Service Function Chaining Use Cases In Data Centers
draft-ietf-sfc-dc-use-cases-01**

Abstract

Data center operators deploy a variety of layer 4 through layer 7 service functions in both physical and virtual form factors. Most traffic originating, transiting, or terminating in the data center is subject to treatment by multiple service functions.

This document describes use cases that demonstrate the applicability of Service Function Chaining (SFC) within a data center environment and provides SFC requirements for data center centric use cases, with primary focus on Enterprise data centers.

Status of this Memo

This Internet-Draft is submitted in full conformance with the provisions of [BCP 78](#) and [BCP 79](#).

Internet-Drafts are working documents of the Internet Engineering Task Force (IETF). Note that other groups may also distribute working documents as Internet-Drafts. The list of current Internet-Drafts is at <http://datatracker.ietf.org/drafts/current/>.

Internet-Drafts are draft documents valid for a maximum of six months and may be updated, replaced, or obsoleted by other documents at any time. It is inappropriate to use Internet-Drafts as reference material or to cite them other than as "work in progress."

This Internet-Draft will expire on January 22, 2015.

Copyright Notice

Copyright (c) 2014 IETF Trust and the persons identified as the

Kumar, et al.
1]

Expires January 22, 2015

[Page

document authors. All rights reserved.

This document is subject to [BCP 78](#) and the IETF Trust's Legal Provisions Relating to IETF Documents (<http://trustee.ietf.org/license-info>) in effect on the date of publication of this document. Please review these documents carefully, as they describe your rights and restrictions with respect to this document. Code Components extracted from this document must include Simplified BSD License text as described in Section 4.e of the Trust Legal Provisions and are provided without warranty as described in the Simplified BSD License.

Table of Contents

1.	Introduction	3
1.1.	Requirements Language	4
2.	Definition Of Terms	4
3.	Use Cases	6
3.1.	Traffic Types	6
3.2.	North-South Traffic	6
3.2.1.	Sample north-south service function chains	8
3.2.2.	Sample north-south SFC description	8
3.3.	East-West Traffic	9
3.3.1.	Sample east-west service function chains	10
3.3.2.	Sample east-west SFC description	10
3.4.	Multi-tenancy	11
3.5.	SFCs in data centers	12
3.6.	Inter-datacenter SFCs	13
3.6.1.	Methods for inter-datacenter SFCs	13
3.6.2.	Considerations for inter-datacenter SFCs	16
4.	Drawbacks Of Existing Service Chaining Methods	17
5.	General Requirements	20

[6.](#) Acknowledgements
[21](#)

[7.](#) Contributors
[21](#)

[8.](#) IANA Considerations
[21](#)

[9.](#) Security Considerations
[22](#)

[10.](#) References
[22](#)

[10.1.](#) Normative References
[22](#)

[10.2.](#) Informative References
[22](#)

Authors' Addresses
[22](#)

1. Introduction

Data centers -- enterprise, cloud or service provider -- deploy service nodes at various points in the network topology. These nodes provide a range of service functions and the set of service functions hosted at a given service node may overlap with service functions hosted at other service nodes.

Often, data center topologies follow a hierarchical design with core, aggregation, access and virtual access layers of network devices.

In such topologies service nodes are deployed either in the aggregation or access layers. More recent data center designs utilize a folded CLOS topology to improve scale, performance and resilience while ensuring deterministic hop count between end points. In such spine-leaf topologies, service nodes are often deployed at compute or virtual access layers as well as physical access layers.

In large scale networks, such as carrier networks, there are many data centers distributed across large geographies. Each data center deploys service nodes and service functions of varied types on a range of hardware.

The primary purpose of deploying service functions at different points in the network is to apply service functions to different types of traffic:

- a. Traffic originating at physical or virtual workloads in the data center and destined to physical or virtual workloads in the data center; for example three-tiered deployment of applications: web, application, and database tiers, with traffic flowing between the adjacent tiers.
- b. Traffic originating at a location remote to the data center and destined to physical or virtual workloads in the data center; for example traffic originating at a branch or regional office, destined to one of the primary data centers in an Enterprise, or traffic originating at one of the tenants of a Service Provider destined to that tenants applications in the Service Provider data center. Yet another variant of this type of traffic includes third party vendors and partners of the data center operator remotely accessing their applications in the data center over secure connections.
- c. Traffic that is originating at a location remote to the data

center and destined to a location remote to the data center but transiting through the data center; for example traffic originating at a mobile device destined to servers in the Internet routed through the data center to in order to service

it.

Servicing of traffic involves directing the traffic through a series of service functions that may be located at different places in the network or within a single device connected to the network or any combination in between. Delivery of multiple service functions in a sequence, in a datacenter or among multiple data centers, thus creates many requirements on the overall service delivery architecture. Such architectures may be termed service function chaining architectures while the list of service functions applied to the traffic is a Service Function Chain (SFC).

1.1. Requirements Language

The key words "MUST", "MUST NOT", "REQUIRED", "SHALL", "SHALL NOT", "SHOULD", "SHOULD NOT", "RECOMMENDED", "MAY", and "OPTIONAL" in this document are to be interpreted as described in [RFC 2119](#) [[RFC2119](#)].

2. Definition Of Terms

Additional terms are defined in [[I-D.ietf-sfc-problem-statement](#)], which the reader may find helpful.

End Point (EP): A device or an application that is the ultimate origination or destination entity of specific traffic. Mobile devices, desktop or server computers and applications running on them are some examples.

Workload (WL): A physical or virtual machine performing a dedicated task that consumes compute, storage, network and other resources.

This may include web servers, database servers, storage servers and a variety of application servers.

Service Function (SF): A function that is responsible for specific treatment of received packets. A Service Function can act at the

network layer or other OSI layers. A Service Function can be a virtual instance or be embedded in a physical network element. One of multiple Service Functions can be embedded in the same network element. Multiple instances of the Service Function can be enabled in the same administrative domain. A non-exhaustive list of Service Functions includes: firewalls, WAN and application acceleration, Deep Packet Inspection (DPI), server load balancers, NAT44 [[RFC3022](#)], NAT64 [[RFC6146](#)], HOST_ID injection, HTTP Header Enrichment functions, TCP optimizer, etc.

Service Node (SN): A virtual or physical device that hosts one or more service functions, which can be accessed via the network location associated with it.

Classifier (CF): The entity responsible for selecting traffic as well as a service chain, based on policy, and forwarding the selected traffic on the service chain.

Deep Packet Inspection (DPI): service function that performs stateful inspection of traffic, identification of applications and policy enforcement, among others.

Intrusion Detection and/or Prevention System (IDS/IPS): Is a DPI SN with additional capabilities to recognize malware and other threats and take corrective action.

Edge Firewall (EdgeFW): SN hosting service functions such as VPN, DHCP, NAT, IP-Audit, Protocol Inspection, DPI etc. with policies primarily focusing on threats external to the data center.

Segment Firewall (SegFW): SN hosting a subset of the functions in the EdgeFW not including VPN and is deployed to protect traffic crossing segments, such as VLANs.

Application Firewall (AppFW): service function that isolates traffic within a segment or protects from application specific threats. This falls into the same class as DPI but deployed much closer to the applications. It is an intra-segment firewall.

Application Delivery Controller (ADC): service function that distributes traffic across a pool of servers (applications) for efficient resource utilization, application scaling as well as to provide high availability among others.

Web Optimization Control (WOC): SN hosting service functions to optimize the use of WAN link bandwidth, improve effective user throughput and latencies leading to overall improved user experience. WOC includes various optimizers such as compression, de-duplication, congestion control, application specific optimizers, etc. WOC requires peers at either end of the WAN link to perform optimizations. The scope of this document is limited to the DC side of the WAN link.

Monitoring (MON): SN hosting service functions to obtain operational visibility into the network to characterize network and application performance, troubleshoot performance issues, optimize resource utilization, etc.

Note: The above definitions are generalized. Actual implementations may vary in scope and in a lot of cases the actual service functions hosted on SNs overlap. For instance, DPI function is not only implemented as a standalone service function but is also implemented in EdgeFWs. Likewise EdgeFw functions, such as VPN, are implemented in routers. The terms used are representative of common usage and not absolute deployment.

3. Use Cases

The following sections highlight some of the most common data center use case scenarios and are in no way exhaustive.

3.1. Traffic Types

IT assets in an enterprise are consolidated into a few data centers located centrally. This consolidation stems from regulatory compliance regarding security, control on the enterprise assets, operational cost savings, disaster recovery strategies, etc. The data center resources are accessible from any geographic location whether inside or outside the enterprise network. Further, enterprise data centers may be organized along lines of businesses, with each business treated as a tenant, thereby supporting multi-tenancy.

Service provider data centers have similar requirements as the enterprise. Data centers may be distributed regionally and globally to support the needs of their tenants. Multi-tenancy underlines every consideration in such data centers: resources and assets are organized & managed on tenant boundaries, policies are organized along tenant boundaries, traffic is segregated and policies enforced on tenant boundaries, etc. This is true in all "as a service" models: IaaS, PaaS and SaaS.

This leads to two primary types of traffic: North-South and East-West, both with different service requirements.

3.2. North-South Traffic

North-South traffic originates from outside the data center and is typically associated with users - onsite, remote and VPN - conducting their jobs. The traffic may also be associated with consumers accessing news, email, social media and other websites. This traffic is typically destined to applications or resources hosted in the data centers. Increasing adoption of BYOD and social networking applications requires traffic be analyzed, application and users be identified, transactions be authorized, and at the same time security

- requires VPN termination prior to WOC. Likewise EdgeFW may not be effective on WOC traffic. Vendor implementations of SNs enable choices for various deployments and ordering. For instance EdgeFW detects the presence of WOC through TCP options or explicit configuration and hence WOC may even be deployed on the traffic that has passed through the EdgeFW. Constructing service function chains in the underlay network thus requires complex topology.

3.2.1. Sample north-south service function chains

SFC-1. EdgeFW

SFC-2. EdgeFW : ADC

SFC-3. EdgeFW : ADC : AppFW

SFC-4. WOC : EdgeFW : ADC : AppFW

SFC-5. WOC : EdgeFW : MON : ADC : AppFW

3.2.2. Sample north-south SFC description

Sample service chains numbered SFC-1 through SFC-5 capture the essence of services required on the north-south traffic.

SFC-1: This represents the simplest of use cases where a remote or mobile worker accesses a specific data center server. Traffic comes into the data center on VPN and is terminated on the EdgeFW. EdgeFW subjects the traffic to its policies, which may in turn select other service functions such as DPI, IPS/IDS, hosted on the EdgeFW. As an alternative deployment, some of these service functions may be hosted outside the EdgeFW and reachable via VLAN stitching. EdgeFW policy permitting, traffic is allowed to its destination.

SFC-2: This is an extension of SFC-1. Traffic instead of destined to a specific server is destined to a data center application that is front-ended by an ADC. The EdgeFW performs its function as before and the traffic is allowed, policy permitting. This traffic reaches its virtual destination, the ADC. ADC, based on local policy, which includes among other things predictors to select the real destination, determines the appropriate application instance. ADCs are stateful and ensure the return traffic pass through them by performing source NAT. Since many applications require the original source address, ADC preserves the original address in extension headers of the HTTP protocol. Traffic is then forwarded on to the ultimate destination - the real application workload.

SFC-3: This extends SFC-2. The segment where the application server resides may be shared with other applications and resources. To segregate these applications and resources further fine grain policies may be required and are enforced via a security appliance such as the AppFW. As a consequence AppFW first services the traffic from the load balancer before it is forwarded to its ultimate destination, the application server.

SFC-4: This is a variant of SFC-3 with WOC being part of the chain. This represents the use case where users at a branch office access the data center resources. The WOC SNs located at either end of the WAN optimize the traffic first. The WOC located in the datacenter requires a mechanism to steer traffic to it while not deployed inline with the traffic. This is achieved either with PBR or VLAN stitching. WOC treated traffic is subject to firewall policies, which may lead to the application of SFs such as protocol inspection, DPI, IDS/IPS and then forwarded to its virtual destination, the ADC.

SFC-5: This is similar to SFC-4. An additional service - MON, is used to collect and analyze traffic entering and leaving the data center. This monitoring and analysis of traffic helps maintain performance levels of the infrastructure to achieve service level agreements, particularly in SP data centers.

3.3. East-West Traffic

This is the predominant traffic in data centers today. Server virtualization has led to the new paradigm where virtual machines can migrate from one server to another across the datacenter. This explosion in east-west traffic is leading to newer data center network fabric architectures that provide consistent latencies from one point in the fabric to another.

The key difference with east-west from the north-south traffic is in the kind of threats and the security needs thereof. Unlike north-south traffic where security threats may come from outside the data center, any threat to this traffic comes from within the data center.



Figure 2: Service functions applied to East-West traffic

Service functions applied on the east-west traffic is captured in a generalized fashion in Figure 2. ADCs, although shown as isolated SNs in each of the tiers, is often consolidated into a smaller number

of ADC SNs shared among the different tiers. Virtual IPs in such ADCs represent the individual ADC instances. Flows are terminated at the VIPs and re-initiated towards the load balanced workloads.

As an example, HTTP GET request arriving at ADC1 is load balanced on to a webserver pool represented as Workload1. In order to respond to

the GET request, Workload1 generates traffic to an application server

in a pool represented as Workload2 through ADC2, which load balances the webserver initiated traffic. Likewise, the application server, as part of processing the webserver's request generates traffic to a DB server pool represented as Workload3 through ADC3, which load balances the application server initiated traffic. The traffic arriving at different ADCs, in this example, can be arriving at different VIPs, instead, each corresponding to its tier but belonging

to the same ADC. In this sense, traffic flow across the tiers is VIP centric as opposed to device instance.

Traffic traversing between the ADC and the selected server in each tier, is subject to monitoring and one or more application firewalls specializing in different kinds and aspects of threats. These again can be shared just as the ADC due to steering mechanisms although it adds complexity in network configuration.

3.3.1. Sample east-west service function chains

SFC-6. SegFW : ADC : MON : AppFW

3.3.2. Sample east-west SFC description

SFC-6: In a typical three tiered architecture, requests coming to a webserver trigger interaction with application servers, which in turn trigger interaction with the database servers. It has to be

noted that each of these tiers are deployed in their own

segments

or zones for isolation, optimization and security. SegFW enforces the security policies between the tiers and facilitates isolation at the segment level or address space re-use via NAT

Kumar, et al.
10]

Expires January 22, 2015

[Page

deployment. ADC provides the distribution, scale and resiliency to the applications while the AppFW protects and isolates traffic within the segment in addition to enforcing application specific security policies. Finally, monitoring service enables visibility into application traffic, which in turn is used to maintain application performance levels.

3.4. Multi-tenancy

Multi-tenancy is relevant in both enterprise as well as service provider data centers although it is the primary differentiator between service provider (SP) and enterprise datacenter.

Enterprises

treat organizations or business units within the enterprise as tenants and thus require tenant aware service models.

Multi-tenant service delivery is achieved in two primary ways: a) SNs

themselves are tenant aware - every SN is built to support multiple tenants. b) SN instances are dedicated for each tenant. In both the cases, the SP manages the SNs.

To support multi-tenant aware service functions or SNs, traffic being

serviced by a service function chain has to be identified by a tenant

identifier. A tenant identifier has to be carried along with the traffic to be serviced. It is typical of tenant assets to be deployed in an isolated layer2 or layer3 domain such as VLAN, VXLAN or VRF. It has to be noted that the SNs themselves maybe deployed

in

different domains to suit the deployment needs of the SP and hence using the domain in which the SN is deployed is not an option. Although such a model is feasible it removes the deployment flexibility for the service providers.

3.5. SFCs in data centers

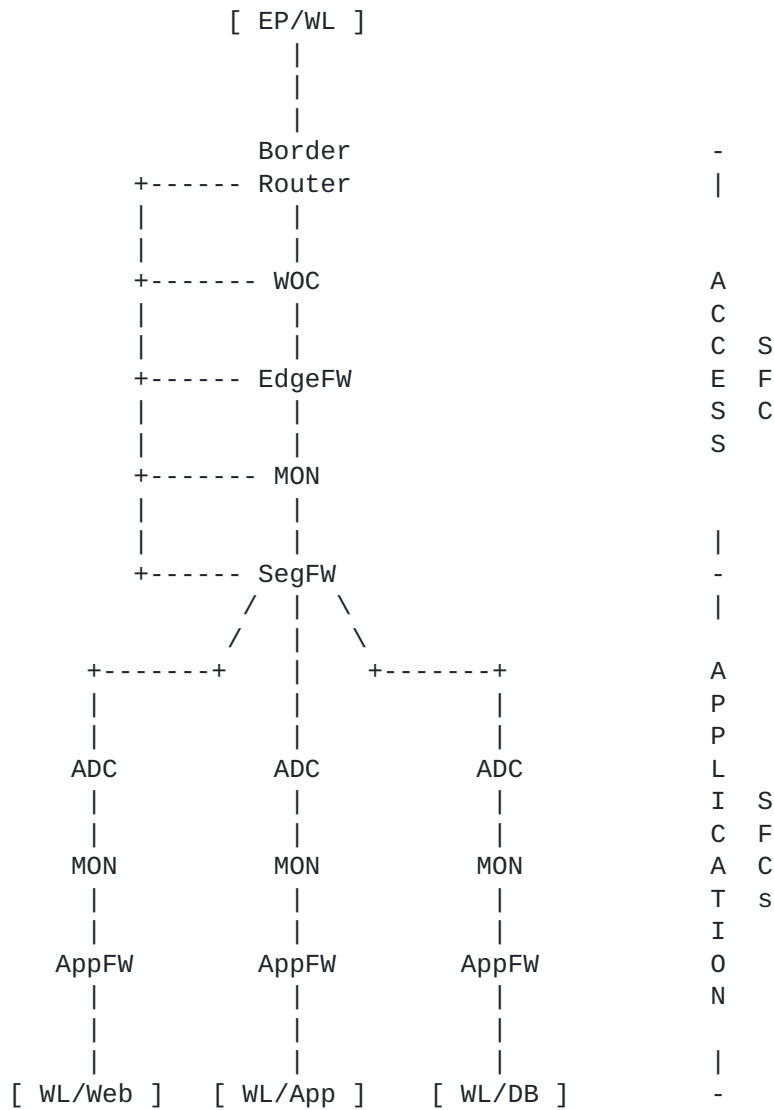

Figure 3: Service function chains in data center

Figure 3 shows the global view of SFCs applied in an enterprise or service provider data center. At a high level the SFCs can be broadly categorized into two types:

1. Access SFCs
2. Application SFCs

Access SFCs are focused on servicing traffic entering and leaving the data center while Application SFCs are focused on servicing traffic destined to applications.

Service providers deploy a single "Access SFC" and multiple "Application SFCs" for each tenant. Enterprise data center operators on the other hand may not have a need for Access SFCs depending on the size and requirements of the enterprise. Where such Access SFCs are indeed needed, such as large enterprises, the operator may deploy a bare minimum Access SFC instead. Such simple Access SFCs include WOC and VPN SFs to support the branch and mobile user traffic while at the same time utilizing the security policies in the application SFCs. The latter is the case in de-perimeterized network architectures where security policies are enforced close to the resources and applications as opposed to the WAN edge.

3.6. Inter-datacenter SFCs

In carrier networks, operators may deploy multiple data centers dispersed geographically. Each data center may host different types of service functions. For example, latency sensitive or high usage service functions are deployed in regional data centers while other latency tolerant, low usage service functions are deployed in global or central data centers. In such deployments, SFCs may span multiple data centers and enables operators to deploy services in a flexible and inexpensive way. These SFCs are referred to as the inter-datacenter SFCs in this draft.

3.6.1. Methods for inter-datacenter SFCs

The following are two methods to construct inter-datacenter SFCs:

1. Inter-datacenter SFCs with multiple SFC domains
2. Inter-datacenter SFCs with a single SFC domain

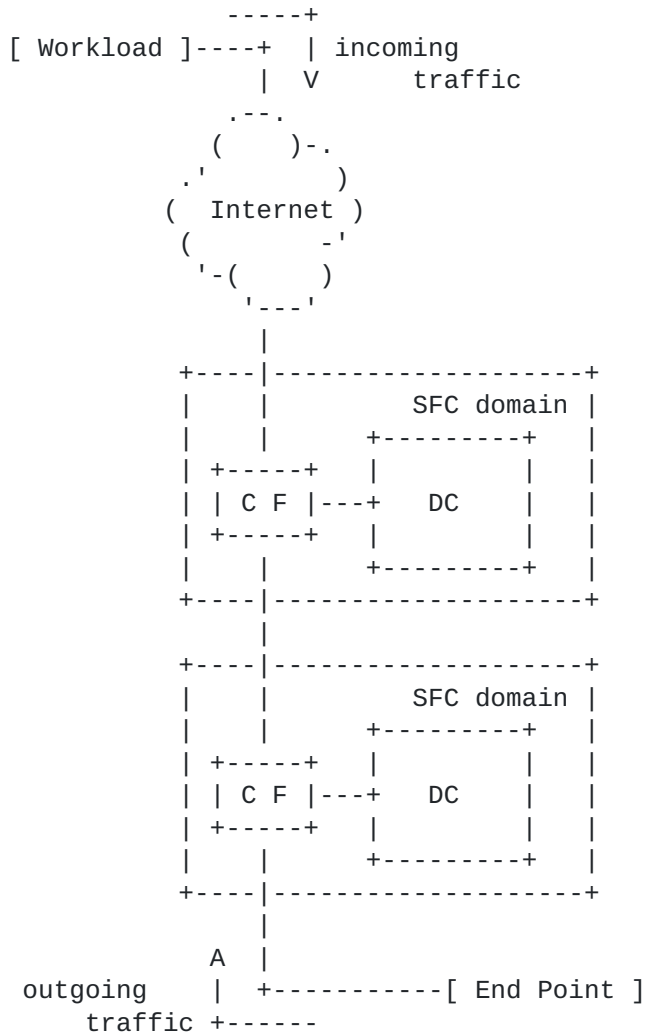

Figure 4: Inter-datacenter SFC with multiple SFC domains

Figure 4 shows inter-datacenter SFC with multiple SFC domains. In this method, services are provided by SFCs spanning multiple independent SFC domains. SFC management is limited to each domain: control plane is constrained to its SFC domain and SFCs are fragmented and initiated in each SFC domain. If both data centers are located in-line, a method of forwarding packets between data centers is required.

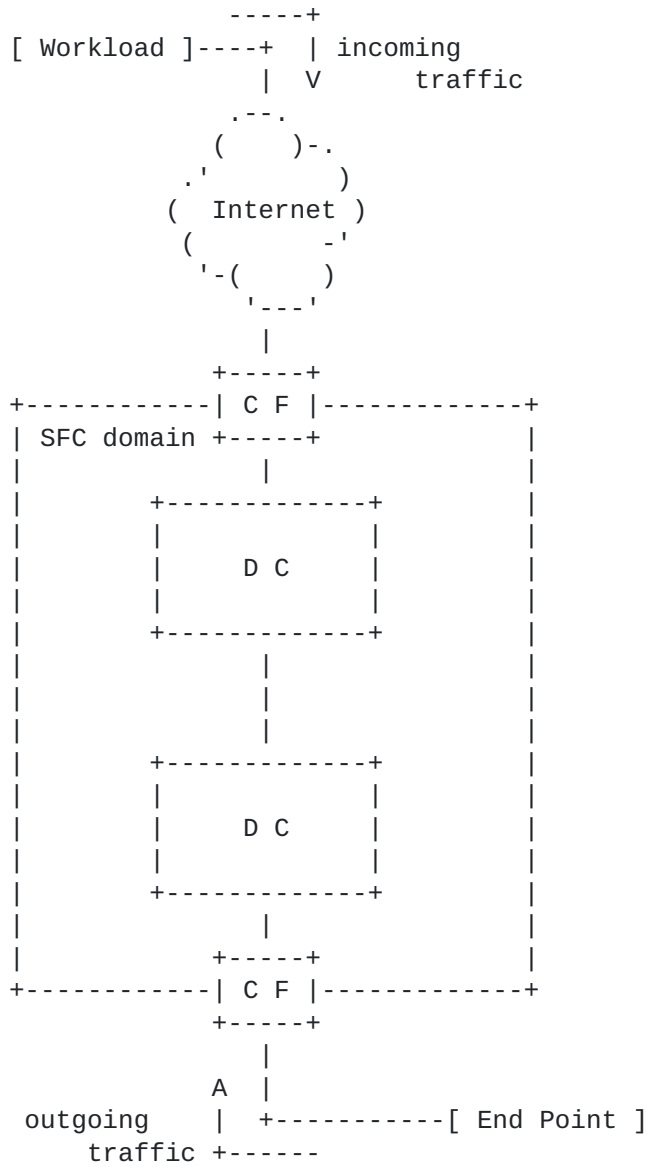

Figure 5: Inter-datacenter SFC with single SFC domains

Figure 5 shows inter datacenter SFC with a single SFC domain. In this method, services are provided across multiple data centers, which are connected with virtualized paths and grouped into a single SFC domain.

In multiple SFC domain case, it is simple to control and manage the SFC domain. However, it is difficult to hand over context data between data centers, whether context data are conveyed out of band

in the control plane or, in band - with traffic. In addition, the cost of classification is high, as it is performed twice in each SFC domain - once in each direction. On the other hand, in the single SFC domain case, it is easy to hand over context data between data centers, but control of SFC domains becomes complex as integrated operation across multiple data centers is required.

3.6.2. Considerations for inter-datacenter SFCs

Inter-datacenter SFC must consider many design aspects, two important among them are :

1. Handing over context data
2. Multiple classification points

Handing over context data : Metadata sharing among SFC components enables many use cases and services. If context data cannot be passed across data centers, some services provided by SFC would be restricted. For example, it is difficult to create SFCs across multiple data centers because service functions cannot simply share information, with each other, between the data centers.

Multiple classification points : In a large SFC domain containing multiple datacenters distributed over large geographies, classification of incoming traffic and outgoing traffic may happen at different points, depending on the deployment model. If classification of incoming traffic and outgoing traffic are forced to happen at the same point, as shown in Figure 6, all traffic may traverse long distances leading to inefficient resource consumption and increased latencies.

- DB-1. Policy based purely on VLANs is no longer sufficient. Connecting SNS to each other to construct a service chain thus makes it very static and removes deployment flexibility. As can be seen from the sample north-south service chains, a large number of VLANs not only have to be stitched in a certain fashion to achieve a basic SFC, it is simply not flexible to share the SNS among different SFCs as even simple sharing among a few SNS becomes intractable from basic configuration perspective let alone future changes or manageability aspects.
- DB-2. Traffic does not always have to be steered through all the SNS of a traditional VLAN stitched service chain. In Figure 1, traffic from the border router is not always necessary to flow through the WOC as remote or mobile worker may not have a WOC peer deployed. Connecting multiple VLANs among service nodes to overcome to achieve this only aggravates the problem of deployment and manageability. Truly, there exists a need for dynamically determining the next sub SFC at such branching points to avoid forcing all traffic through the same SFC.
- DB-3. Virtual environments require the virtual SNS be migration capable just like the compute workloads. As a consequence it is simply not feasible to continue VLAN stitching in the hybrid data centers. Every time a virtual SN migrates, such as the AppFW in Figure 1 and Figure 2, the operator has to ensure the VLANs are provisioned in the destination. Further, stretching the VLANs across the network may not be an option for the operator or even worse the virtual SN may be L3 hop away from the previous SN.
- DB-4. Policy Based Routing (PBR) can be used to move traffic to SNS. Although it provides a much better granularity than VLAN stitching it suffers from the requirement to configure such policies all along the path to the SNS. In Figure 1, if WOC is multiple hops away from the border router, all network elements in between border router and WOC need to be configured with consistent policies.
- DB-5. Source NAT (SNAT) is required by some SNS, such as ADC in Figure 1, in order to ensure traffic sent to the load balanced servers pass through the ADC in reverse direction. However, SNAT removes the ability to detect the originator of the traffic. Using HTTP extension header to pass originator information is not only an overhead but addresses only one

specific protocol.

Kumar, et al.
18]

Expires January 22, 2015

[Page

- DB-6. Static service chains do not allow for modifying the SFCs as they require the ability to add SNs or remove SNs to scale up and down the service capacity. Likewise the ability to dynamically pick one among the many SN instance is not available. For instance, WOC must scale to support the high data rate of traffic flowing to the data center. Likewise, AppFWs must scale up to not impact the workload throughput. Further they may be required to scale within tenant boundaries.
- DB-7. Static SFCs constructed over the under lay network cannot pass metadata to the SNs. Border Router in Figure 1 cannot pass policy based tags derived locally at the start of the SFC all the way through the SFC. Such metadata is necessary to enforce consistent security policies across the network, as one example.
- DB-8. In multi-tenant deployments, the segment on which the SN is deployed may not correspond to the segment assigned to the tenant in which the workloads are hosted. In Figure 2, AppFW may be deployed on a different segment than the Workload. As a consequence, it is not viable to derive the tenant segment simply based on the tag associated with the incoming traffic at the AppFW. This ultimately prevents the ability to have the same SN serve multiple tenants. Forcing the SN to be on the same segment as the tenants' workload limits deployment flexibility.
- DB-9. Traffic may originate in a physical or virtual network or transit these networks before being delivered to the SNs for servicing. The following is very complex to achieve with the existing SFC mechanism, primarily due to very conflicting nature of their environments: physical and static vs. virtual and dynamic.
- A. Physical SN servicing traffic originating in the virtual access network.
 - B. Virtual SN servicing traffic originating in the physical network.
- DB-10. Although SNs are purpose built service appliances, it is neither a requirement nor an indication of how service functions are implemented in emerging data centers with commodity compute and storage capabilities. AppFW in Figure 1, for instance, may be built and deployed as a virtual SN. Further, SFCs are limited to exclusively

physical or virtual SNS and not a mix. This excludes the

Kumar, et al.
19]

Expires January 22, 2015

[Page

ability to combine the benefits offered by physical SNs with the flexibility and agility of the virtual SNs. The EdgeFW in Figure 1, for instance, may be a purpose built SN to take advantage of SFs implemented in hardware while the AppFW may be a virtual SN deployed to be close to the virtual workload and may even move with the workload in the virtual environment.

DB-11. Troubleshooting is one of the predominant issues plaguing SFC deployments. The reasons range from misconfiguration at different elements in the network that are responsible for directing traffic to the service nodes, to, tracking the traffic paths starting from the point of entry into the DC to the point of exit to the application through various SNs. When desired services are not effective on certain traffic, determining the reason is simply not viable in a large scale deployment. Figure 3 provides a view of the complexity in terms of the permutations of the SFCs, their paths in the network and the configuration in the network elements required and managed for proper operation.

5. General Requirements

The above use cases and the drawbacks thereof lead to the following general requirements in today's evolving hybrid datacenters to apply SFCs to traffic.

- GR1. SFC policies MUST be applicable at the edges - network elements as well as the workloads.
- GR2. SFC policies MUST be applicable to either Ingress or Egress traffic at network elements as well as workloads.
- GR3. SFC MUST support virtual as well as physical SNs.
- GR4. SFC SHOULD support the ability to mix virtual and physical SNs in the same SFC.
- GR5. SFC SNs MUST be deployable L2 or L3 hop away from the SFC application points - network elements or workloads.
- GR6. SFC traffic MUST be allowed to follow paths not constrained by the underlying static network topology.

- GR7. SFC SNs MUST be able identify tenant traffic without being tied to the underlying topology
- GR8. SFCs MUST support the ability to pass metadata among the SNs or between the SNs and the network elements.
- GR9. A composite SFC SHOULD be achievable by way of joining sub SFCs, branching to sub SFCs where necessary.
- GR10. SFCs SHOULD NOT require SNAT inside the SFs to attract traffic back to them
- GR11. SFCs SHOULD have the ability to choose SN instances dynamically, prior to forwarding traffic to them.
- GR12. An OAM mechanism to easily troubleshoot as well as validate the paths traversed by the SFCs SHOULD be supported.

6. Acknowledgements

The authors would like to thank Paul Quinn, Jim Guichard, Jim French, Larry Kreeger and Nagaraj Bagepalli for their review and comments.

A special thanks to Abhijit Patra for his guidance.

7. Contributors

The following people are active contributors to this draft, they have provided content and review feedback :

Cesar Obediente
Cisco Systems, Inc.
Email: cobedien@cisco.com

Kengo Naito
NTT
Email: naito.kengo@lab.ntt.co.jp

8. IANA Considerations

This memo includes no request to IANA.

9. Security Considerations

Security of traffic being serviced is very important in the use cases described in this document. The SNs deployed as part of the SFC are expected to include SFs specifically addressing the security aspect either individually or in concert with other SFs. In this regard organizational security policies are expected to drive the security posture adapted in the SFCs. However, securing the traffic moving between the SFs or SNs is not a consideration beyond the methods used for moving such traffic.

10. References

10.1. Normative References

[RFC2119] Bradner, S., "Key words for use in RFCs to Indicate Requirement Levels", [BCP 14](#), [RFC 2119](#), March 1997.

10.2. Informative References

- [I-D.ietf-sfc-problem-statement]
Quinn, P. and T. Nadeau, "Service Function Chaining Problem Statement", [draft-ietf-sfc-problem-statement-07](#) (work in progress), June 2014.
- [RFC3022] Srisuresh, P. and K. Egevang, "Traditional IP Network Address Translator (Traditional NAT)", [RFC 3022](#), January 2001.
- [RFC6146] Bagnulo, M., Matthews, P., and I. van Beijnum, "Stateful NAT64: Network Address and Protocol Translation from IPv6 Clients to IPv4 Servers", [RFC 6146](#), April 2011.

Authors' Addresses

Surendra Kumar
Cisco Systems, Inc.
170 W. Tasman Dr.
San Jose, CA 95134

Email: smkumar@cisco.com

Internet-Draft
2014

SFC DC Use Cases

July

Mudassir Tufail
Citi
238 King George Rd
Warren, NJ 07059-5153

Email: mudassir.tufail@citi.com

Sumandra Majee
F5 Networks
90 Rio Robles
San Jose, CA 95134

Email: S.Majee@f5.com

Claudiu Captari
Telstra Corporation
Level 15, 525 Collins Street
Melbourne, 3000

Email: Claudiu.Captari@team.telstra.com

Shunsuke Homma
NTT
3-9-11, Midori-cho Musashino-shi
Tokyo, 180-8585
Japan

Email: homma.shunsuke@lab.ntt.co.jp

