

Secure Inter-Domain Routing Working Group
Internet-Draft
Updates: [6487](#) (if approved)
Intended Status: Standards Track
Expires: October 15, 2012

M. Reynolds
IPSw
S. Turner
IECA
S. Kent
BBN
April 13, 2012

A Profile for BGPSEC Router Certificates,
Certificate Revocation Lists, and Certification Requests
draft-ietf-sidr-bgpsec-pki-profiles-03

Abstract

This document defines a standard profile for X.509 certificates for the purposes of supporting validation of Autonomous System (AS) paths in the Border Gateway Protocol (BGP), as part of an extension to that protocol known as BGPSEC. BGP is a critical component for the proper operation of the Internet as a whole. The BGPSEC protocol is under development as a component to address the requirement to provide security for the BGP protocol. The goal of BGPSEC is to design a protocol for full AS path validation based on the use of strong cryptographic primitives. The end-entity (EE) certificates specified by this profile are issued under Resource Public Key Infrastructure (RPKI) Certification Authority (CA) certificates, containing the AS Identifier Delegation extension, to routers within the Autonomous System (AS). The certificate asserts that the router(s) holding the private key are authorized to send out secure route advertisements on behalf of the specified AS. This document also profiles the Certificate Revocation List (CRL), profiles the format of certification requests, and specifies Relying Party certificate path validation procedures. The document extends the RPKI; therefore, this document updates the RPKI Resource Certificates Profile ([RFC 6487](#)).

Status of this Memo

This Internet-Draft is submitted in full conformance with the provisions of [BCP 78](#) and [BCP 79](#).

Internet-Drafts are working documents of the Internet Engineering Task Force (IETF). Note that other groups may also distribute working documents as Internet-Drafts. The list of current Internet-Drafts is at <http://datatracker.ietf.org/drafts/current/>.

Internet-Drafts are draft documents valid for a maximum of six months and may be updated, replaced, or obsoleted by other documents at any time. It is inappropriate to use Internet-Drafts as reference

Internet-Draft

BGPSEC Router PKI Profiles

April 13, 2012

material or to cite them other than as "work in progress."

Copyright Notice

Copyright (c) 2012 IETF Trust and the persons identified as the document authors. All rights reserved.

This document is subject to [BCP 78](#) and the IETF Trust's Legal Provisions Relating to IETF Documents (<http://trustee.ietf.org/license-info>) in effect on the date of publication of this document. Please review these documents carefully, as they describe your rights and restrictions with respect to this document. Code Components extracted from this document must include Simplified BSD License text as described in Section 4.e of the Trust Legal Provisions and are provided without warranty as described in the Simplified BSD License.

1. Introduction

This document defines a profile for X.509 end-entity (EE) certificates [[RFC5280](#)] for use in the context of certification of Autonomous System (AS) paths in the Border Gateway Protocol Security (BGPSEC) protocol. Such certificates are termed "BGPSEC Router Certificates". The holder of the private key associated with a BGPSEC Router Certificate is authorized to send secure route advertisements (BGPSEC UPDATES) on behalf of the AS named in the certificate. That is, a router holding the private key may send to its BGP peers, route advertisements that contain the specified AS number as the last item in the AS PATH attribute. A key property that BGPSEC will provide is that every AS along the AS PATH can verify that the other ASes along the path have authorized the advertisement of the given route (to the next AS along the AS PATH).

This document is a profile of [[RFC6487](#)], which is a profile of [[RFC5280](#)], and it updates [[RFC6487](#)]. It establishes requirements imposed on a Resource Certificate that is used as a BGPSEC Router Certificate, i.e., it defines constraints for certificate fields and extensions for the certificate to be valid in this context. This document also profiles the Certificate Revocation List (CRL) and certification requests. Finally, this document specifies the Relying Party (RP) certificate path validation procedures.

1.1. Terminology

It is assumed that the reader is familiar with the terms and concepts described in "A Profile for X.509 PKIX Resource Certificates" [[RFC6487](#)], "BGPSEC Protocol Specification" [[ID.sidr-bgpsec-protocol](#)], "A Border Gateway Protocol 4 (BGP-4)" [[RFC4271](#)], "BGP Security

Vulnerabilities Analysis" [[RFC4272](#)], "Considerations in Validating the Path in BGP" [[RFC5123](#)], and "Capability Advertisement with BGP-4" [[RFC5492](#)].

The key words "MUST", "MUST NOT", "REQUIRED", "SHALL", "SHALL NOT", "SHOULD", "SHOULD NOT", "RECOMMENDED", "NOT RECOMMENDED", "MAY", and "OPTIONAL" in this document are to be interpreted as described in [[RFC2119](#)].

2. Describing Resources in Certificates

Figure 1 depicts some of the entities in the RPKI and some of the products generated by RPKI entities. IANA issues a Certification Authority (CA) to a Regional Internet Registries (RIR). The RIR, in turn, issues a CA certificate to an Internet Service Providers (ISP). The ISP in turn issues End-Entity (EE) Certificates to itself as well as CRLs. These certificates are referred to as "Resource Certificates", and are profiled in [[RFC6487](#)]. The [[RFC6480](#)] envisioned using Resource Certificates to generate Manifests [[RFC6486](#)] and Route Origin Authorizations (ROAs) [[RFC6482](#)]. ROAs and Manifests also include the Resource Certificates used to sign them.

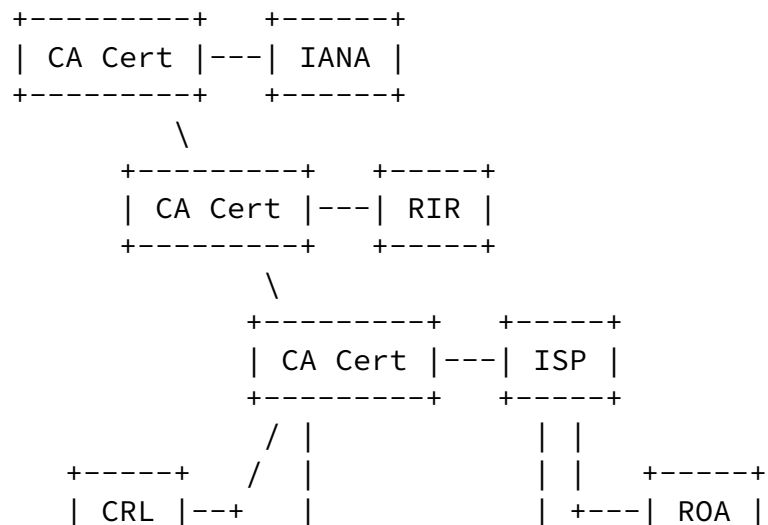

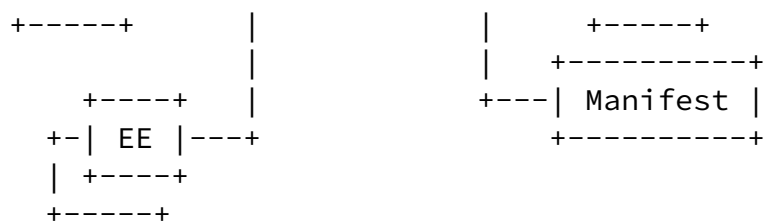

Figure 1

This document defines another type of Resource Certificate, which is referred to as a "BGPSEC Router Certificate". The purpose of this

certificate is explained in [Section 1](#) and falls within the scope of appropriate uses defined within [\[RFC6484\]](#). The issuance of BGPSEC Router Certificates has minimal impact on RPKI CAs because the RPKI CA certificate and CRL profile remain unchanged (i.e., they are as specified in [\[RFC6487\]](#)). Further, the algorithms used to generate RPKI CA certificates that issue the BGPSEC Router Certificates and the CRLs necessary to check the validity of the BGPSEC Router Certificates remain unchanged (i.e., they are as specified in [\[RFC6485\]](#)). The only impact is that the RPKI CAs will need to be able to process a profiled certificate request (see [Section 5](#)) signed with algorithms found in [\[ID.sidr-bgpsec-algs\]](#). The use of BGPSEC Router Certificates in no way affects RPKI RPs that process Manifests and ROAs because the public key found in the BGPSEC Router Certificate is only ever used to verify the signature on the BGPSEC certificate request (only CAs process these), another BGPSEC Router Certificate (only BGPSEC routers process these), and the signature on a BGPSEC Update Message [\[ID.sidr-bgpsec-protocol\]](#) (only BGPSEC routers process these).

Only the differences between this profile and the profile in [\[RFC6487\]](#) are listed. Note that BGPSEC Router Certificates are EE certificates and as such there is no impact on process described in [\[ID.sidr-algorithm-agility\]](#).

3. Updates to [\[RFC6487\]](#)

3.1 BGPSEC Router Certificate Fields

A BGPSEC Router Certificate is a valid X.509 public key certificate,

consistent with the PKIX profile [[RFC5280](#)], containing the fields listed in this section. This profile is also based on [[RFC6487](#)] and only the differences between this profile and the profile in [[RFC6487](#)] are listed.

[3.1.1.1](#) Subject

This field identifies the router to which the certificate has been issued. Consistent with [[RFC6487](#)], only two attributes are allowed in the Subject field: common name and serial number. Moreover, the only common name encoding options that are supported are printableString and UTF8String. For BGPSEC Router Certificates, it is RECOMMENDED that the common name attribute contain the literal string "ROUTER-" followed by the 32-bit AS Number [[RFC3779](#)] encoded as eight hexadecimal digits and that the serial number attribute contain the 32-bit BGP Identifier [[RFC4271](#)] (i.e., the router ID) encoded as eight hexadecimal digits. If the same certificate is issued to more than one router (hence the private key is shared among these routers), the choice of the router ID used in this name is at

the discretion of the Issuer. Note that router IDs are not guaranteed to be unique across the Internet, and thus the Subject name in a BGPSEC Router Certificate issued using this convention also is not guaranteed to be unique across different issuers. However, each certificate issued by an individual CA MUST contain a Subject name that is unique within that context.

[3.1.2.](#) Subject Public Key Info

Refer to section 3.1 of [[ID.sidr-bgpsec-algs](#)].

[3.1.3.](#) BGPSEC Router Certificate Version 3 Extension Fields

The following X.509 V3 extensions MUST be present (or MUST be absent, if so stated) in a conforming BGPSEC Router Certificate, except where explicitly noted otherwise. No other extensions are allowed in a conforming BGPSEC Router Certificate.

[3.1.3.1.](#) Extended Key Usage

BGPSEC Router Certificates MUST include the Extended Key Usage (EKU) extension. As specified, in [[RFC6487](#)] this extension MUST be marked

as non-critical. This document defines one EKU for BGPSEC Router Certificates:

```
id-kp OBJECT IDENTIFIER ::=
  { iso(1) identified-organization(3) dod(6) internet(1)
    security(5) mechanisms(5) pkix(7) kp(3) }
```

```
id-kp-bgpsec-router OBJECT IDENTIFIER ::= { id-kp TBD }
```

Relying Parties MUST require the extended key usage extension to be present in a BGPSEC Router Certificate. If multiple KeyPurposeId values are included, the relying parties need not recognize all of them, as long as the required KeyPurposeId value is present. BGPSEC RPs MUST reject certificates that do not contain the BGPSEC Router EKU even if they include the anyExtendedKeyUsage OID defined in [\[RFC5280\]](#).

[3.1.3.2.](#) Subject Information Access

This extension is not used in BGPSEC Router Certificates. It MUST be omitted.

[3.1.3.3.](#) IP Resources

This extension is not used in BGPSEC Router Certificates. It MUST be omitted.

[3.1.3.4.](#) AS Resources

Each BGPSEC Router Certificate MUST include the AS Resource Identifier Delegation extension, as specified in [section 4.8.11 of \[RFC6487\]](#). The AS Resource Identifier Delegation extension MUST include exactly one AS number, and the "inherit" element MUST NOT be specified.

[3.2.](#) BGPSEC Router Certificate Request Profile

Refer to [section 6 of \[RFC6487\]](#). The only differences between this profile and the profile in [\[RFC6487\]](#) are:

- o The ExtendedKeyUsage extension request MUST be included and the CA MUST honor the request;

- o The SubjectPublicKeyInfo and PublicKey fields are specified in [[ID.sidr-bgpsec-algs](#)]; and,
- o The request is signed with the algorithms specified in [ID.sidr-bgpsec-algs].

3.3. BGPSEC Router Certificate Validation

The validation procedure used for BGPSEC Router Certificates is identical to the validation procedure described in [Section 7 of RFC6487](#). The exception is that the constraints applied come from this specification (e.g., in step 3: the certificate contains all the field that must be present - refers to the fields that are required by this specification).

The differences are as follows:

- o BGPSEC Router Certificates MUST include the BGPSEC EKU defined in [Section 3.1.3.1](#).
- o BGPSEC Router Certificates MUST NOT include the SIA extension.
- o BGPSEC Router Certificates MUST NOT include the IP Resource extension.
- o BGPSEC Router Certificates MUST include the AS Resource Identifier Delegation extension.
- o BGPSEC Router Certificate MUST include the "Subject Public Key Info" described in [[ID.sidr-bgpsec-algs](#)] as it updates [[RFC6485](#)].

NOTE: The cryptographic algorithms used by BGPSEC routers are

found in [[ID.sidr-bgpsec-algs](#)]. Currently, the algorithms specified in [[ID.sidr-bgpsec-algs](#)] and [[RFC6485](#)] are different. BGPSEC RPs will need to support algorithms that are needed to validate BGPSEC signatures as well as the algorithms that are needed to validate signatures on BGPSEC certificates, RPKI CA certificates, and RPKI CRLs.

4. Design Notes

The BGPSEC Router Certificate profile is based on the Resource Certificate profile as specified in [[RFC6485](#)]. As a result, many of the design choices herein are a reflection of the design choices that were taken in that prior work. The reader is referred to [[RFC6484](#)] for a fuller discussion of those choices.

[5.](#) Security Considerations

The Security Considerations of [[RFC6487](#)] apply.

A bgpsec certificate will fail RPKI validation, as defined in [[RFC6487](#)], because the algorithm suite is different. Consequently, a RP needs to identify the EKU before applying the correspondent validation.

A BGPSEC Router Certificate is an extension of the RPKI [[RFC6480](#)] to encompass routers. It is a building block of the larger BGPSEC security protocol used to validate signatures on BGPSEC Signature-Segment origination of Signed-Path segments [ID.sidr-bgpsec-protocol]. Thus its essential security function is the secure binding of an AS number to a public key, consistent with the RPKI allocation/assignment hierarchy.

[6.](#) IANA Considerations

None.

[7.](#) Acknowledgements

We would like to thanks Geoff Huston, George Michaelson, and Robert Loomans for their work on [[RFC6487](#)], which this work is based on. In addition, the efforts of Steve Kent and Matt Lepinski were instrumental in preparing this work. Additionally, we'd like to thank Roque Gagliano, Sandra Murphy, and Geoff Huston for their reviews and comments.

[8.](#) References

8.1. Normative References

- [RFC2119] Bradner, S., "Key words for use in RFCs to Indicate Requirement Levels", [BCP 14](#), [RFC 2119](#), March 1997.
- [RFC3779] Lynn, C., Kent, S., and K. Seo, "X.509 Extensions for IP Addresses and AS Identifiers", [RFC 3779](#), June 2004.
- [RFC4271] Rekhter, Y., Ed., Li, T., Ed., and S. Hares, Ed., "A Border Gateway Protocol 4 (BGP-4)", [RFC 4271](#), January 2006.
- [RFC5280] Cooper, D., Santesson, S., Farrell, S., Boeyen, S., Housley, R., and W. Polk, "Internet X.509 Public Key Infrastructure Certificate and Certificate Revocation List (CRL) Profile", [RFC 5280](#), May 2008.
- [RFC6485] Huston, G., "The Profile for Algorithms and Key Sizes for Use in the Resource Public Key Infrastructure (RPKI)", [RFC 6485](#), February 2012.
- [RFC6487] Huston, G., Michaelson, G., and R. Loomans, "A Profile for X.509 PKIX Resource Certificates", [RFC 6487](#), February 2012.
- [ID.sidr-bgpsec-algs] Reynolds, M. and S. Turner, "BGP Algorithms, Key Formats, & Signature Formats", [draft-ietf-sidr-bgpsec-algs](#), work-in-progress.

8.2. Informative References

- [RFC4272] Murphy, S., "BGP Security Vulnerabilities Analysis", [RFC 4272](#), January 2006.
- [RFC5123] White, R. and B. Akyol, "Considerations in Validating the Path in BGP", [RFC 5123](#), February 2008.
- [RFC5492] Scudder, J. and R. Chandra, "Capabilities Advertisement with BGP-4", [RFC 5492](#), February 2009.
- [RFC6480] Lepinski, M. and S. Kent, "An Infrastructure to Support Secure Internet Routing", [RFC 6480](#), February 2012.
- [RFC6482] Lepinski, M., Kent, S., and D. Kong, "A Profile for Route Origin Authorizations (ROAs)", [RFC 6482](#), February 2012.
- [RFC6484] Kent, S., Kong, D., Seo, K., and R. Watro, "Certificate Policy (CP) for the Resource Public Key Infrastructure

(RPKI)", [BCP 173](#), [RFC 6484](#), February 2012.

[RFC6486] Austein, R., Huston, G., Kent, S., and M. Lepinski,
"Manifests for the Resource Public Key Infrastructure
(RPKI)", [RFC 6486](#), February 2012.

[ID.sidr-algorithm-agility] Gagliano, R., Kent, S., and S. Turner,
"Algorithm Agility Procedure for RPKI", [draft-ietf-sidr-
algorithm-agility](#), work-in-progress.

[ID.sidr-bgpsec-protocol] Lepinski, M., "BGPSEC Protocol
Specification", [draft-ietf-sidr-bgpsec-protocol](#), work-in-
progress.

[Appendix A](#). ASN.1 Module

```
BGPSECEKU { iso(1) identified-organization(3) dod(6) internet(1)
  security(5) mechanisms(5) pkix(7) id-mod(0) TBD }
```

```
DEFINITIONS EXPLICIT TAGS ::=
```

```
BEGIN
```

```
-- EXPORTS ALL --
```

```
-- IMPORTS NOTHING --
```

```
-- OID Arc --
```

```
id-kp OBJECT IDENTIFIER ::= {
  iso(1) identified-organization(3) dod(6) internet(1)
  security(5) mechanisms(5) kp(3) }
```

```
-- BGPSEC Router Extended Key Usage --
```

```
id-kp-bgpsec-router OBJECT IDENTIFIER ::= { id-kp TBD }
```

```
END
```

[Appendix B](#). Example BGPSEC Router Certificate

[Appendix C](#). Example BGPSEC Router Certificate Request

[Appendix D](#). Change Log

Please delete this section prior to publication.

[D.1](#) Changes from turner-bgpsec-pki-profiles-02 to sidr-bgpsec-pki-profiles-03

Updated s3.3 to clarify restrictions on path validation procedures are in this specification (1st para was reworded).

Updated s3.3 to point to s3.1.3.1 for BGPSEC ECU (thanks Tom).

[D.2](#) Changes from turner-bgpsec-pki-profiles-01 to sidr-bgpsec-pki-profiles-02

Updated references.

[D.3](#) Changes from turner-bgpsec-pki-profiles-00 to sidr-bgpsec-pki-profiles-01

Added an ASN.1 Module and corrected the id-kp OID in s3.1.3.1.

[D.4](#) Changes from turner-bgpsec-pki-profiles-00 to sidr-bgpsec-pki-profiles-00

Added this change log.

Amplified that a BGPSEC RP will need to support both the algorithms in [[ID.sidr-bgpsec-algs](#)] for BGPSEC and the algorithms in [[ID.sidr-rpki-algs](#)] for certificates and CRLs.

Changed the name of AS Resource extension to AS Resource Identifier Delegation to match what's in [RFC 3779](#).

[D.5](#) Changes from turner-bgpsec-pki-profiles -01 to -02

Added text in [Section 2](#) to indicate that there's no impact on the

procedures defined in [[ID.sidr-algorithm-agility](#)].

Added a security consideration to let implementers know the BGPSEC certificates will not pass RPKI validation [[RFC6487](#)] and that keying off the EKU will help tremendously.

[D.6](#) Changes from turner-bgpsec-pki-profiles -00 to -01

Corrected [Section 2](#) to indicate that CA certificates are also RPKI

Reynolds & Turner Expires October 15, 2012 [Page 10]

Internet-Draft BGPSEC Router PKI Profiles April 13, 2012

certificates.

Removed sections and text that was already in [[RFC6487](#)]. This will make it easier for reviewers to figure out what is different.

Modified [Section 6](#) to use 2119-language.

Removed requirement from [Section 6](#) to check that the AS # in the certificate is the last number in the AS path information of each BGP UPDATE message. Moved to [[ID.sidr-bgpsec-protocol](#)].

Authors' Addresses

Mark Reynolds
Island Peak Software
328 Virginia Road
Concord, MA 01742

Email: mcr@islandpeaksoftware.com

Sean Turner
IECA, Inc.
3057 Nutley Street, Suite 106
Fairfax, VA 22031
USA

EMail: turners@ieca.com

Steve Kent
Raytheon BBN Technologies
10 Moulton St.
Cambridge, MA 02138

Email: kent@bbn.com

Reynolds & Turner

Expires October 15, 2012

[Page 11]