

Internet Engineering Task Force  
Internet Draft  
Document: [draft-ietf-sipping-call-flows-01.txt](#)  
Category: Informational  
July 2002  
Expires: December 2002

Alan Johnston  
WorldCom  
Steve Donovan  
Robert Sparks  
Chris Cunningham  
Dean Willis  
Jonathan Rosenberg  
dynamicsoft  
Kevin Summers  
Sonus  
Henning Schulzrinne  
Columbia University

## Session Initiation Protocol Call Flow Examples

### Status of this Memo

This document is an Internet-Draft and is in full conformance with all provisions of [Section 10 of RFC2026](#).

Internet-Drafts are working documents of the Internet Engineering Task Force (IETF), its areas, and its working groups. Note that other groups may also distribute working documents as Internet-Drafts. Internet-Drafts are draft documents valid for a maximum of six months and may be updated, replaced, or obsoleted by other documents at any time. It is inappropriate to use Internet-Drafts as reference material or to cite them other than as "work in progress."

The list of current Internet-Drafts can be accessed at

<http://www.ietf.org/ietf/1id-abstracts.txt>

The list of Internet-Draft Shadow Directories can be accessed at

<http://www.ietf.org/shadow.html>.

### Abstract

This informational document gives examples of Session Initiation Protocol (SIP) call flows. Elements in these call flows include SIP User Agents and Clients, SIP Proxy and Redirect Servers, and Gateways to the PSTN (Public Switch Telephone Network). Scenarios include SIP Registration, SIP to SIP calling, SIP to Gateway, Gateway to SIP, and Gateway to Gateway via SIP. Call flow diagrams and message details are shown. PSTN telephony protocols are illustrated using ISDN (Integrated Services Digital Network), ANSI ISUP (ISDN User Part), and FGB (Feature Group B) circuit associated signaling. PSTN calls are illustrated using global telephone numbers from the PSTN and private extensions served on by a PBX (Private Branch Exchange). Example SIP messages used for testing during SIP interoperability test events include SIP "torture test" messages, and messages with invalid parameters, methods, and tags.



## Table of Contents

<a href="#">1</a>	Overview.....	<a href="#">4</a>
<a href="#">1.1</a>	General Assumptions.....	<a href="#">4</a>
<a href="#">1.2</a>	Legend for Message Flows.....	<a href="#">5</a>
<a href="#">1.3</a>	SIP Protocol Assumptions.....	<a href="#">6</a>
<a href="#">2</a>	SIP Registration.....	<a href="#">7</a>
<a href="#">2.1</a>	Success Scenarios.....	<a href="#">7</a>
<a href="#">2.1.1</a>	SIP Client New Registration.....	<a href="#">7</a>
<a href="#">2.1.2</a>	User updates contact list.....	<a href="#">9</a>
<a href="#">2.1.3</a>	User Requests Current Contact List.....	<a href="#">11</a>
<a href="#">2.1.4</a>	User Cancels Registration.....	<a href="#">12</a>
<a href="#">2.2</a>	Failure Scenarios.....	<a href="#">13</a>
<a href="#">2.2.1</a>	Unsuccessful SIP registration.....	<a href="#">13</a>
<a href="#">3</a>	SIP to SIP Dialing.....	<a href="#">15</a>
<a href="#">3.1</a>	Success Scenarios.....	<a href="#">15</a>
<a href="#">3.1.1</a>	Successful Simple SIP to SIP.....	<a href="#">16</a>
<a href="#">3.1.2</a>	Successful SIP to SIP through two proxies.....	<a href="#">19</a>
<a href="#">3.1.3</a>	Successful SIP to SIP with Multi Proxy Authentication.....	<a href="#">29</a>
<a href="#">3.1.4</a>	Successful SIP to SIP with Proxy failure.....	<a href="#">39</a>
<a href="#">3.1.5</a>	Successful SIP to SIP through SIP ALG .....	<a href="#">47</a>
<a href="#">3.1.6</a>	Successful SIP to SIP via Redirect and Proxy SDP in ACK... <a href="#">55</a>	
<a href="#">3.1.7</a>	Successful SIP to SIP with re-INVITE.....	<a href="#">61</a>
<a href="#">3.2</a>	Failure Scenarios.....	<a href="#">67</a>
<a href="#">3.2.1</a>	Unsuccessful SIP to SIP no answer.....	<a href="#">67</a>
<a href="#">3.2.2</a>	Unsuccessful SIP to SIP busy.....	<a href="#">74</a>
<a href="#">3.2.3</a>	Unsuccessful SIP to SIP no response.....	<a href="#">79</a>
<a href="#">3.2.4</a>	Unsuccessful SIP to SIP Temporarily Unavailable.....	<a href="#">84</a>
<a href="#">4</a>	SIP to Gateway Dialing.....	<a href="#">90</a>
<a href="#">4.1</a>	Success Scenarios.....	<a href="#">90</a>
<a href="#">4.1.1</a>	Successful SIP to ISUP PSTN call.....	<a href="#">91</a>
<a href="#">4.1.2</a>	Successful SIP to ISDN PBX call.....	<a href="#">99</a>
<a href="#">4.1.3</a>	Successful SIP to ISUP PSTN call with overflow.....	<a href="#">107</a>
<a href="#">4.2</a>	Failure Scenarios.....	<a href="#">115</a>
<a href="#">4.2.1</a>	Unsuccessful SIP to PSTN call: Treatment from PSTN.....	<a href="#">116</a>
<a href="#">4.2.2</a>	Unsuccessful SIP to PSTN: REL w/Cause from PSTN.....	<a href="#">123</a>
<a href="#">4.2.3</a>	Unsuccessful SIP to PSTN: ANM Timeout.....	<a href="#">127</a>
<a href="#">5</a>	Gateway to SIP Dialing.....	<a href="#">133</a>
<a href="#">5.1</a>	Success Scenarios.....	<a href="#">133</a>
<a href="#">5.1.1</a>	Successful PSTN to SIP call.....	<a href="#">134</a>
<a href="#">5.1.2</a>	Successful PSTN to SIP call, Fast Answer.....	<a href="#">140</a>
<a href="#">5.1.3</a>	Successful PBX to SIP call.....	<a href="#">145</a>
<a href="#">5.2</a>	Failure Scenarios.....	<a href="#">151</a>
<a href="#">5.2.1</a>	Unsuccessful PSTN to SIP REL, SIP error mapped to REL.... <a href="#">151</a>	
<a href="#">5.2.2</a>	Unsuccessful PSTN to SIP REL, SIP busy mapped to REL.... <a href="#">153</a>	
<a href="#">5.2.3</a>	Unsuccessful PSTN->SIP, SIP error interworking to tones.. <a href="#">157</a>	
<a href="#">5.2.4</a>	Unsuccessful PSTN->SIP, ACM timeout.....	<a href="#">161</a>
<a href="#">5.2.5</a>	Unsuccessful PSTN->SIP, ACM timeout, stateless Proxy.... <a href="#">165</a>	
<a href="#">5.2.6</a>	Unsuccessful PSTN->SIP, Call Abandonment.....	<a href="#">168</a>

[6](#) Gateway to Gateway Dialing via SIP Network.....[174](#)  
[6.1](#) Success Scenarios.....[174](#)  
[6.1.1](#) Successful ISUP PSTN to ISUP PSTN call.....[175](#)

- [6.1.2 Successful FGB PBX to ISDN PBX call with overflow.....](#)[182](#)
- [7 SIP Test Messages.....](#)[191](#)
- [7.1 INVITE Parser Torture Test Message.....](#)[191](#)
- [7.2 INVITE with Proxy-Require and Require.....](#)[192](#)
- [7.3 INVITE with Unknown Schemes in URIs and URLs.....](#)[192](#)
- [7.4 REGISTER with Y2038 Test.....](#)[193](#)
- [7.5 INVITE with inconsistent Accept and message body.....](#)[193](#)
- [7.6 INVITE with non-SDP message body.....](#)[194](#)
- [7.7 Unknown Method Message.....](#)[194](#)
- [7.8 Unknown Method with CSeq Error.....](#)[195](#)
- [7.9 REGISTER with Unknown Authorization Scheme.....](#)[195](#)
- [7.10 Multiple SIP Request in a Single Message.....](#)[196](#)
- [7.11 INVITE missing Required Headers.....](#)[197](#)
- [7.12 INVITE with Duplicate Required Headers.....](#)[197](#)
- [7.13 INVITE with Illegal Expires Header.....](#)[198](#)
- [7.14 200 OK Response with Broadcast Via Header.....](#)[198](#)
- [7.15 INVITE with Invalid Via and Contact Headers.....](#)[199](#)
- [7.16 INVITE with Incorrect Content-Length Header.....](#)[200](#)
- [7.17 INVITE with Invalid Value for Content-Length.....](#)[200](#)
- [7.18 INVITE with Garbage after Message Body.....](#)[201](#)
- [7.19 INVITE with Error in Display Name in To Header.....](#)[201](#)
- [7.20 INVITE with long tokens, Call-ID, and SIP URIs.....](#)[202](#)
- [7.21 INVITE with Illegal Enclosing of Request-URI in "<>".....](#)[202](#)
- [7.22 INVITE with Illegal LWS within Elements of Request-URI...](#) [203](#)
- [7.23 INVITE with Illegal >1 SP between elements Request-URI...](#) [204](#)
- [7.24 INVITE with a Legal SIP URI With Escaped Characters.....](#)[204](#)
- [7.25 INVITE with the Illegal Escaped Headers Request-URI.....](#)[205](#)
- [7.26 INVITE with Unknown Scheme in Request-URI.....](#)[206](#)
- [7.27 OPTIONS with no LWS between display name and "<".....](#)[206](#)
- [7.28 OPTIONS with Extra WS between display name and "<".....](#)[206](#)
- [7.29 INVITE with an Illegal Date Format.....](#)[207](#)
- [7.30 INVITE with Passed Expires Time.....](#)[207](#)
- [7.31 INVITE with Max-Forwards Set to Zero.....](#)[208](#)
- [7.32 REGISTER with Escaped Header in a Legal Contact URI.....](#)[209](#)
- [7.33 REGISTER with Escaped Header in an Illegal Contact URI...](#) [209](#)
- [7.34 INVITE with Long Values in Headers.....](#)[210](#)
- [7.35 OPTIONS with Multiple Headers.....](#)[211](#)
- [7.36 INVITE with Large Number of SDP Attributes and Long URI..](#) [211](#)
- [7.37 REGISTER with Contact Parameter.....](#)[212](#)
- [7.38 REGISTER with a URI Parameter.....](#)[213](#)
- [7.39 INVITE with Unquoted Display Name with Tokens.....](#)[213](#)
- [7.40 INVITE with Unquoted Display Name with Non-Token Chars...](#) [213](#)
- [7.41 INVITE with Unknown \(Higher\) Protocol Version Start Line.](#) [214](#)
- [8 Security Considerations .....](#)[214](#)
- [9 IANA Considerations .....](#)[215](#)
- [10 Acknowledgements.....](#)[215](#)
- [11 References.....](#)[215](#)



## **1 Overview**

The call flows shown in this document were developed in the design of a carrier-class SIP IP Telephony network. They represent an example minimum set of functionality for SIP to be used in IP Telephony applications. The message examples were developed during the SIP interoperability tests known as SIPit.

It is the hope of the authors that this document will be useful for SIP implementors, designers, and protocol researchers alike and will help further the goal of a standard SIP implementation for IP Telephony. It is envisioned that as changes to the standard and additional RFCs are added that this document will reflect those changes and represent the current state of a standard interoperable SIP IP Telephony implementation.

Note that this document is informational, and is NOT NORMATIVE on any aspect of SIP or SIP/PSTN interworking.

These call flows are based on the current version 2.0 of SIP in [[RFC3261](#)] with SDP usage described in [[RFC3264](#)].

Various PSTN signaling protocols are illustrated in this document: ISDN (Integrated Services Digital Network), ANSI ISUP (ISDN User Part) and FGB (Feature Group B) circuit associated signaling. They were chosen to illustrate the nature of SIP/PSTN interworking - they are not a complete or even representative set. Also, some details and parameters of these PSTN protocols have been omitted. For full information about SIP to ISUP mapping, refer to [[SIP-ISUP](#)].

Finally, some example messages are given along with expected behavior of clients and servers.

### **1.1 General Assumptions**

A number of architecture, network, and protocol assumptions underly the call flows in this document. Note that these assumptions are not requirements. They are outlined in this section so that they may be taken into consideration and to aid in the understanding of the call flow examples.

The authentication of SIP User Agents in these example call flows is performed using SIP Digest as defined in [[RFC3261](#)] and [[RFC2617](#)].

Throughout this document the call flows show a network where the proxy servers authenticate users on behalf of gateways. Gateways may also authenticate users directly. Both of these are reasonable usages of SIP. If gateways do not authenticate directly they would be to refuse requests from entities other than trusted proxy servers with

which they have effective channel security (for example [[RFC2246](#)] or [[RFC2401](#)])."

Johnston, et al.

Informational

[Page 4]



The SIP Proxy Server has access to a Location Service and other databases. Information present in the Request-URI and the context (From header) is sufficient to determine to which proxy or gateway the message should be routed. In most cases, a primary and secondary route will be determined in case of Proxy or Gateway failure downstream.

Some Proxy Servers in these call flows insert Record-Route headers into requests to ensure that they are in the signaling path for future message exchanges.

Gateways provide tones (ringing, busy, etc) and announcements to the PSTN side based on SIP response messages, or pass along audio in-band tones (ringing, busy tone, etc.) in an early media stream to the SIP side.

The interactions between the Proxy and Gateway can be summarized as follows:

- . The SIP Proxy Server performs digit analysis and lookup and locates the correct gateway.
- . The SIP Proxy Server performs gateway location based on primary and secondary routing.

Telephone numbers are usually represented as SIP URIs. Note that an alternative is the use of the tel URI [[RFC2806](#)].

These flows show UDP for transport. Other transport schemes could also be used.

## **[1.2](#) Legend for Message Flows**

Dashed lines (---) represent signaling messages that are mandatory to the call scenario. These messages can be SIP or PSTN signaling. The arrow indicates the direction of message flow.

Double dashed lines (===) represent media paths between network elements.

Messages with parentheses around their name represent optional messages.

Messages are identified in the Figures as F1, F2, etc. This references the message details in the list that follows the Figure. Comments in the message details are shown in the following form:

```
/* Comments. */
```

### [1.3 SIP Protocol Assumptions](#)

Johnston, et al.

Informational

[Page 5]

This document is informational only and is NOT NORMATIVE in any sense.

For simplicity in reading and editing the document, there are a number of differences between some of the examples and actual SIP messages. For example, the SIP Digest responses are not actual MD5 encodings. Call-IDs are often repeated, and CSeq counts often begin at 1. Header fields are usually shown in the same order. Usually only the minimum required header field set is shown, others that would normally be present such as Accept, Supported, Allow, etc are not shown.

Actors:

Element	Display Name	URI	IP Address
-----	-----	---	-----
User Agent	BigGuy	UserA@atlanta.com	192.168.100.101
User Agent	LittleGuy	UserB@biloxi.com	192.168.200.201
User Agent		UserB@chicago.com	192.168.200.100
Proxy Server		ss1.atlanta.com	192.168.255.111
Proxy/Registrar		ss2.biloxi.com	192.168.156.222
Proxy Server		ss3.chicago.com	192.168.182.333
ALG		alg1.atlanta.com	192.168.255.128
User Agent (Gateway)		gw1.atlanta.com	192.168.255.201
User Agent (Gateway)		gw2.atlanta.com	192.168.255.202
User Agent (Gateway)		gw3.atlanta.com	192.168.255.203
User Agent (Gateway)		ngw1.atlanta.com	192.168.255.101
User Agent (Gateway)		ngw2.atlanta.com	192.168.255.102



**2 SIP Registration**

**2.1 Success Scenarios**

Registration binds a particular device Contact URI with a SIP user AOR (Address of Record).

**2.1.1 SIP Client New Registration**

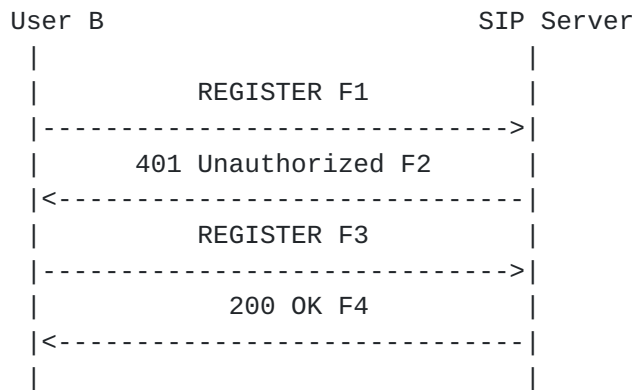

User B sends a SIP REGISTER request to the SIP server. The request includes the user's contact list. The SIP server provides a challenge to User B. User B enters her/his valid user ID and password. User B's SIP client encrypts the user information according to the challenge issued by the SIP server and sends the response to the SIP server. The SIP server validates the user's credentials. It registers the user in its contact database and returns a response (200 OK) to User B's SIP client. The response includes the user's current contact list in Contact headers. The format of the authentication shown is SIP digest. It is assumed that User B has not previously registered with this Server.

Message Details

F1 REGISTER B -> SIP Server

```

REGISTER sip:ss2.biloxi.com SIP/2.0
Via: SIP/2.0/UDP client.biloxi.com:5060;branch=z9hG4bKnashds7
Max-Forwards: 70
From: LittleGuy <sip:UserB@biloxi.com>;tag=a73kszlfl
To: LittleGuy <sip:UserB@biloxi.com>
Call-ID: 1j9FpLxk3uxtm8tn@biloxi.com
CSeq: 1 REGISTER
Contact: <sip:UserB@192.168.200.201>
Content-Length: 0
    
```

F2 401 Unauthorized SIP Server -> User B

Johnston, et al.

Informational

[Page 7]

```
SIP/2.0 401 Unauthorized
Via: SIP/2.0/UDP client.biloxi.com:5060;branch=z9hG4bKnashds7
    ;received=192.168.200.201
From: LittleGuy <sip:UserB@biloxi.com>;tag=a73kszlf1
To: LittleGuy <sip:UserB@biloxi.com>;tag=1410948204
Call-ID: 1j9FpLxk3uxtm8tn@biloxi.com
CSeq: 1 REGISTER
WWW-Authenticate: Digest realm="atlanta.com", qop="auth",
    nonce="ea9c8e88df84f1cec4341ae6cbe5a359",
    opaque="", stale=FALSE, algorithm=MD5
Content-Length: 0
```

F3 REGISTER B -> SIP Server

```
REGISTER sip:ss2.biloxi.com SIP/2.0
Via: SIP/2.0/UDP client.biloxi.com:5060;branch=z9hG4bKnashds7
Max-Forwards: 70
From: LittleGuy <sip:UserB@biloxi.com>;tag=ja743ks76zlf1H
To: LittleGuy <sip:UserB@biloxi.com>
Call-ID: 1j9FpLxk3uxtm8tn@biloxi.com
CSeq: 2 REGISTER
Contact: <sip:UserB@192.168.200.201>
Authorization: Digest username="UserB", realm="atlanta.com"
    nonce="ea9c8e88df84f1cec4341ae6cbe5a359", opaque="",
    uri="sip:ss2.biloxi.com", response="dfe56131d1958046689d83306477ecc"
Content-Length: 0
```

F4 200 OK SIP Server -> B

```
SIP/2.0 200 OK
Via: SIP/2.0/UDP client.biloxi.com:5060;branch=z9hG4bKnashds7
    ;received=192.168.200.201
From: LittleGuy <sip:UserB@biloxi.com>;tag=ja743ks76zlf1H
To: LittleGuy <sip:UserB@biloxi.com>;tag=37GkEhw16
Call-ID: 1j9FpLxk3uxtm8tn@biloxi.com
CSeq: 2 REGISTER
Contact: <sip:UserB@192.168.200.201>;expires=3600
Content-Length: 0
```







To: LittleGuy <sip:UserB@biloxi.com>;tag=34095828jh  
Call-ID: 1j9FpLxk3uxtm8tn@biloxi.com

Johnston, et al.

Informational

[Page 9]

CSeq: 1 REGISTER

Contact: <sip:UserB@192.168.200.201>;expires=3600

Contact: <mailto:UserB@biloxi.com>;expires=4294967295

Content-Length: 0



**2.1.3 User Requests Current Contact List**

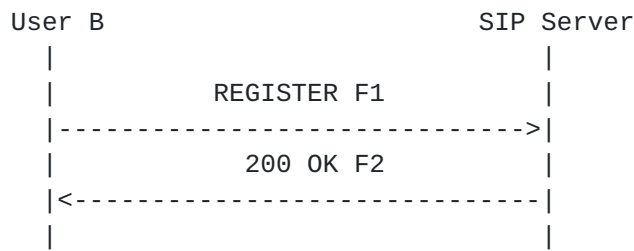

User B sends a register request to the Proxy Server containing no Contact headers, indicating the user wishes to query the server for the user's current contact list. Since the user already has authenticated with the server, the user supplies authentication credentials with the request and is not challenged by the server. The SIP server validates the user's credentials. The server returns a response (200 OK) which includes the user's current registration list in Contact headers.

Message Details

F1 REGISTER B -> SIP Server

```

REGISTER sip:ss2.biloxi.com SIP/2.0
Via: SIP/2.0/UDP client.biloxi.com:5060;branch=z9hG4bKnashds7
Max-Forwards: 70
From: LittleGuy <sip:UserB@biloxi.com>;tag=a73kszlfl
To: LittleGuy <sip:UserB@biloxi.com>
Call-ID: 1j9FpLxk3uxtm8tn@biloxi.com
CSeq: 1 REGISTER
Authorization: Digest username="UserB", realm="atlanta.com",
  nonce="df84f1cec4341ae6cbe5ap359a9c8e88", opaque="",
  uri="sip:ss2.biloxi.com",
  response="aa7ab4678258377c6f7d4be6087e2f60"
Content-Length: 0

```

F2 200 OK SIP Server -> B

```

SIP/2.0 200 OK
Via: SIP/2.0/UDP client.biloxi.com:5060;branch=z9hG4bKnashds7
  ;received=192.168.200.201
From: LittleGuy <sip:UserB@biloxi.com>;tag=a73kszlfl
To: LittleGuy <sip:UserB@biloxi.com>;tag=jqoiweu75
Call-ID: 1j9FpLxk3uxtm8tn@biloxi.com
CSeq: 1 REGISTER
Contact: <sip:UserB@192.168.200.201>;expires=3600
Contact: <mailto:UserB@biloxi.com>;expires=4294967295

```

Content-Length: 0

Johnston, et al.

Informational

[Page 11]

**2.1.4 User Cancels Registration**

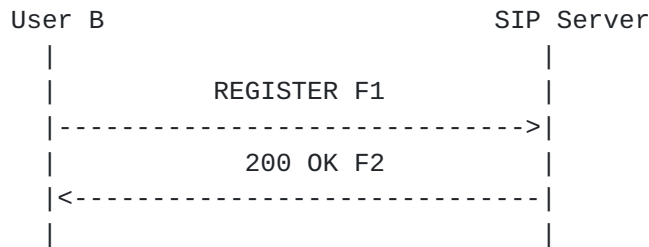

User B wishes to cancel their registration with the SIP server. User B sends a SIP REGISTER request to the SIP server. The request has an expiration period of 0 and applies to all existing contact locations. Since the user already has authenticated with the server, the user supplies authentication credentials with the request and is not challenged by the server. The SIP server validates the user's credentials. It clears the user's contact list, and returns a response (200 OK) to User B's SIP client.

Message Details

F1 REGISTER B -> SIP Server

```

REGISTER sip:ss2.biloxi.com SIP/2.0
Via: SIP/2.0/UDP client.biloxi.com:5060;branch=z9hG4bKnashds7
Max-Forwards: 70
From: LittleGuy <sip:UserB@biloxi.com>;tag=a73kszlfl
To: LittleGuy <sip:UserB@biloxi.com>
Call-ID: 1j9FpLxk3uxtm8tn@biloxi.com
CSeq: 1 REGISTER
Expires: 0
Contact: *
Authorization: Digest username="UserB", realm="atlanta.com",
  nonce="88df84f1cac4341aea9c8ee6cbe5a359", opaque="",
  uri="sip:ss2.biloxi.com",
  response="ff0437c51696f9a76244f0cf1dbabbea"
Content-Length: 0

```

F2 200 OK SIP Server -> B

```

SIP/2.0 200 OK
Via: SIP/2.0/UDP client.biloxi.com:5060;branch=z9hG4bKnashds7
  ;received=192.168.200.201
From: LittleGuy <sip:UserB@biloxi.com>;tag=a73kszlfl
To: LittleGuy <sip:UserB@biloxi.com>;tag=1418nmdsrf
Call-ID: 1j9FpLxk3uxtm8tn@biloxi.com
CSeq: 1 REGISTER

```

Content-Length: 0

Johnston, et al.

Informational

[Page 12]



2.2 Failure Scenarios

2.2.1 Unsuccessful SIP registration

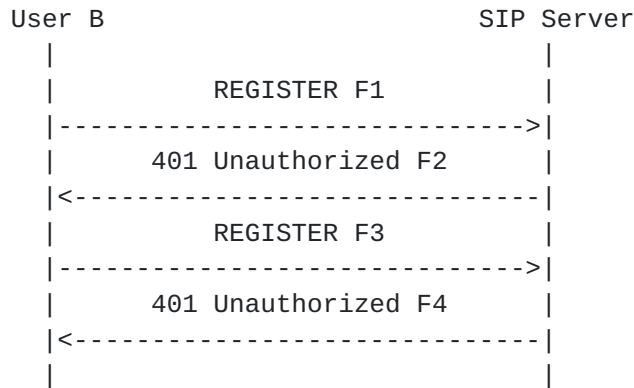

User B sends a SIP REGISTER request to the SIP Server. The SIP server provides a challenge to User B. User B enters her/his user ID and password. User B's SIP client encrypts the user information according to the challenge issued by the SIP server and sends the response to the SIP server. The SIP server attempts to validate the user's credentials, but they are not valid (the user's password does not match the password established for the user's account). The server returns a response (401 Unauthorized) to User B's SIP client.

Message Details

F1 REGISTER B -> SIP Server

```

REGISTER sip:ss2.biloxi.com SIP/2.0
Via: SIP/2.0/UDP client.biloxi.com:5060;branch=z9hG4bKnashds7
Max-Forwards: 70
From: LittleGuy <sip:UserB@biloxi.com>;tag=a73kszlfl
To: LittleGuy <sip:UserB@biloxi.com>
Call-ID: 1j9FpLxk3uxtm8tn@biloxi.com
CSeq: 1 REGISTER
Contact: <sip:UserB@192.168.200.201>
Content-Length: 0

```

F2 Unauthorized SIP Server -> User B

```

SIP/2.0 401 Unauthorized
Via: SIP/2.0/UDP client.biloxi.com:5060;branch=z9hG4bKnashds7
;received=192.168.200.201

```

From: LittleGuy <sip:UserB@biloxi.com>;tag=a73kszlfl  
To: LittleGuy <sip:UserB@biloxi.com>;tag=1410948204

Johnston, et al.

Informational

[Page 13]

Call-ID: 1j9FpLxk3uxtm8tn@biloxi.com  
CSeq: 1 REGISTER  
WWW-Authenticate: Digest realm="atlanta.com", qop="auth",  
    nonce="f1cec4341ae6ca9c8e88df84be55a359",  
    opaque="", stale=FALSE, algorithm=MD5  
Content-Length: 0

F3 REGISTER B -> SIP Server

REGISTER sip:ss2.biloxi.com SIP/2.0  
Via: SIP/2.0/UDP client.biloxi.com:5060;branch=z9hG4bKnashds7  
Max-Forwards: 70  
From: LittleGuy <sip:UserB@biloxi.com>;tag=JueHGuidj28dfga  
To: LittleGuy <sip:UserB@biloxi.com>  
Call-ID: 1j9FpLxk3uxtm8tn@biloxi.com  
CSeq: 2 REGISTER  
Contact: <sip:UserB@192.168.200.201>  
Authorization: Digest username="UserB", realm="atlanta.com",  
    nonce="f1cec4341ae6ca9c8e88df84be55a359", opaque="",  
    uri="sip:ss2.biloxi.com",  
    response="61f8470ceb87d7ebf508220214ed438b"  
Content-Length: 0

/\* The response above encodes the incorrect password \*/

F4 401 Unauthorized SIP Server -> User B

SIP/2.0 401 Unauthorized  
Via: SIP/2.0/UDP client.biloxi.com:5060;branch=z9hG4bKnashds7  
    ;received=192.168.200.201  
From: LittleGuy <sip:UserB@biloxi.com>;tag=JueHGuidj28dfga  
To: LittleGuy <sip:UserB@biloxi.com>;tag=1410948204  
Call-ID: 1j9FpLxk3uxtm8tn@biloxi.com  
CSeq: 2 REGISTER  
WWW-Authenticate: Digest realm="atlanta.com", qop="auth",  
    nonce="84f1c1ae6cbe5ua9c8e88dfa3ecm3459",  
    opaque="", stale=FALSE, algorithm=MD5  
Content-Length: 0



### **3 SIP to SIP Dialing**

#### **3.1 Success Scenarios**

This section details calls between two SIP User Agents (UAs): User A and User B. User A (LittleGuy sip:UserA@atlanta.com) and User B (BigGuy sip:UserB@biloxi.com) are assumed to be SIP phones or SIP-enabled devices. The successful calls show the initial signaling, the exchange of media information in the form of SDP payloads, the establishment of the media session, then finally the termination of the call.

SIP digest authentication is used by Proxy Servers to authenticate the caller User A. It is assumed that User B has registered with Proxy Server Proxy 2 as per [Section 2.1](#) to be able to receive the calls via the Proxy.



**3.1.1 Successful Simple SIP to SIP**

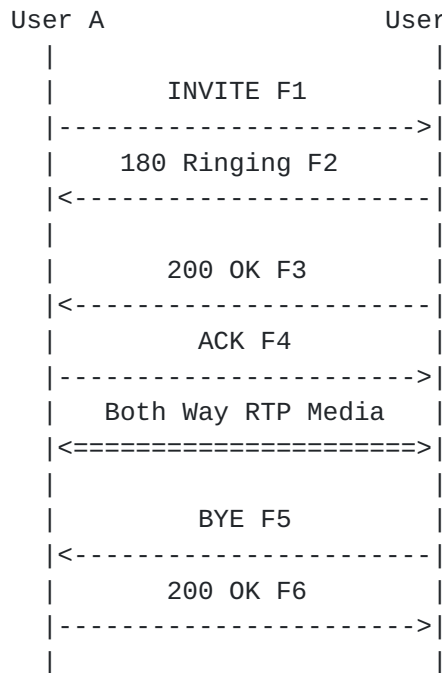

In this scenario, User A completes a call to User B directly.

Message Details

F1 INVITE User A -> User B

```

INVITE sip:UserB@biloxi.com SIP/2.0
Via: SIP/2.0/UDP client.atlanta.com:5060;branch=z9hG4bK74bf9
Max-Forwards: 70
From: BigGuy <sip:UserA@atlanta.com>;tag=9fxced76s1
To: LittleGuy <sip:UserB@biloxi.com>
Call-ID: 3848276298220188511@atlanta.com
CSeq: 1 INVITE
Contact: <sip:UserA@192.168.100.101>
Content-Type: application/sdp
Content-Length: 147

```

```

v=0
o=UserA 2890844526 2890844526 IN IP4 client.atlanta.com
s=-
c=IN IP4 192.168.100.101
t=0 0
m=audio 49172 RTP/AVP 0
a=rtpmap:0 PCMU/8000

```

F2 180 Ringing User B -> User A

Johnston, et al.

Informational

[Page 16]



```
SIP/2.0 180 Ringing
Via: SIP/2.0/UDP client.atlanta.com:5060;branch=z9hG4bK74bf9
    ;received=192.168.100.101
From: BigGuy <sip:UserA@atlanta.com>;tag=9fxced76sl
To: LittleGuy <sip:UserB@biloxi.com>;tag=8321234356
Call-ID: 3848276298220188511@atlanta.com
CSeq: 1 INVITE
Content-Length: 0
```

F3 200 OK User B -> User A

```
SIP/2.0 200 OK
Via: SIP/2.0/UDP client.atlanta.com:5060;branch=z9hG4bK74bf9
    ;received=192.168.100.101
From: BigGuy <sip:UserA@atlanta.com>;tag=9fxced76sl
To: LittleGuy <sip:UserB@biloxi.com>;tag=8321234356
Call-ID: 3848276298220188511@atlanta.com
CSeq: 1 INVITE
Contact: <sip:UserB@192.168.200.201>
Content-Type: application/sdp
Content-Length: 145
```

```
v=0
o=UserB 2890844527 2890844527 IN IP4 client.biloxi.com
s=-
c=IN IP4 192.168.200.201
t=0 0
m=audio 3456 RTP/AVP 0
a=rtpmap:0 PCMU/8000
```

F4 ACK User A -> User B

```
ACK sip:UserB@biloxi.com SIP/2.0
Via: SIP/2.0/UDP client.atlanta.com:5060;branch=z9hG4bK74bf9
Max-Forwards: 70
From: BigGuy <sip:UserA@atlanta.com>;tag=9fxced76sl
To: LittleGuy <sip:UserB@biloxi.com>;tag=8321234356
Call-ID: 3848276298220188511@atlanta.com
CSeq: 1 ACK
Content-Length: 0
```

/\* RTP streams are established between A and B \*/

/\* User B Hangs Up with User A. Note that the CSeq is NOT 2, since User A and User B maintain their own independent CSeq counts. (The INVITE was request 1 generated by User A, and the BYE is request 1 generated by User B) \*/

F5 BYE User B -> User A

Johnston, et al.

Informational

[Page 17]

```
BYE sip:UserA@192.168.100.101 SIP/2.0
Via: SIP/2.0/UDP client.biloxi.com:5060;branch=z9hG4bKnashds7
Max-Forwards: 70
From: LittleGuy <sip:UserB@biloxi.com>;tag=8321234356
To: BigGuy <sip:UserA@atlanta.com>;tag=9fxced76sl
Call-ID: 3848276298220188511@atlanta.com
CSeq: 1 BYE
Content-Length: 0
```

```
F6 200 OK User A -> User B
```

```
SIP/2.0 200 OK
Via: SIP/2.0/UDP client.biloxi.com:5060;branch=z9hG4bKnashds7
;received=192.168.200.201
From: LittleGuy <sip:UserB@biloxi.com>;tag=8321234356
To: BigGuy <sip:UserA@atlanta.com>;tag=9fxced76sl
Call-ID: 3848276298220188511@atlanta.com
CSeq: 1 BYE
Content-Length: 0
```



**3.1.2 Successful SIP to SIP through two proxies**

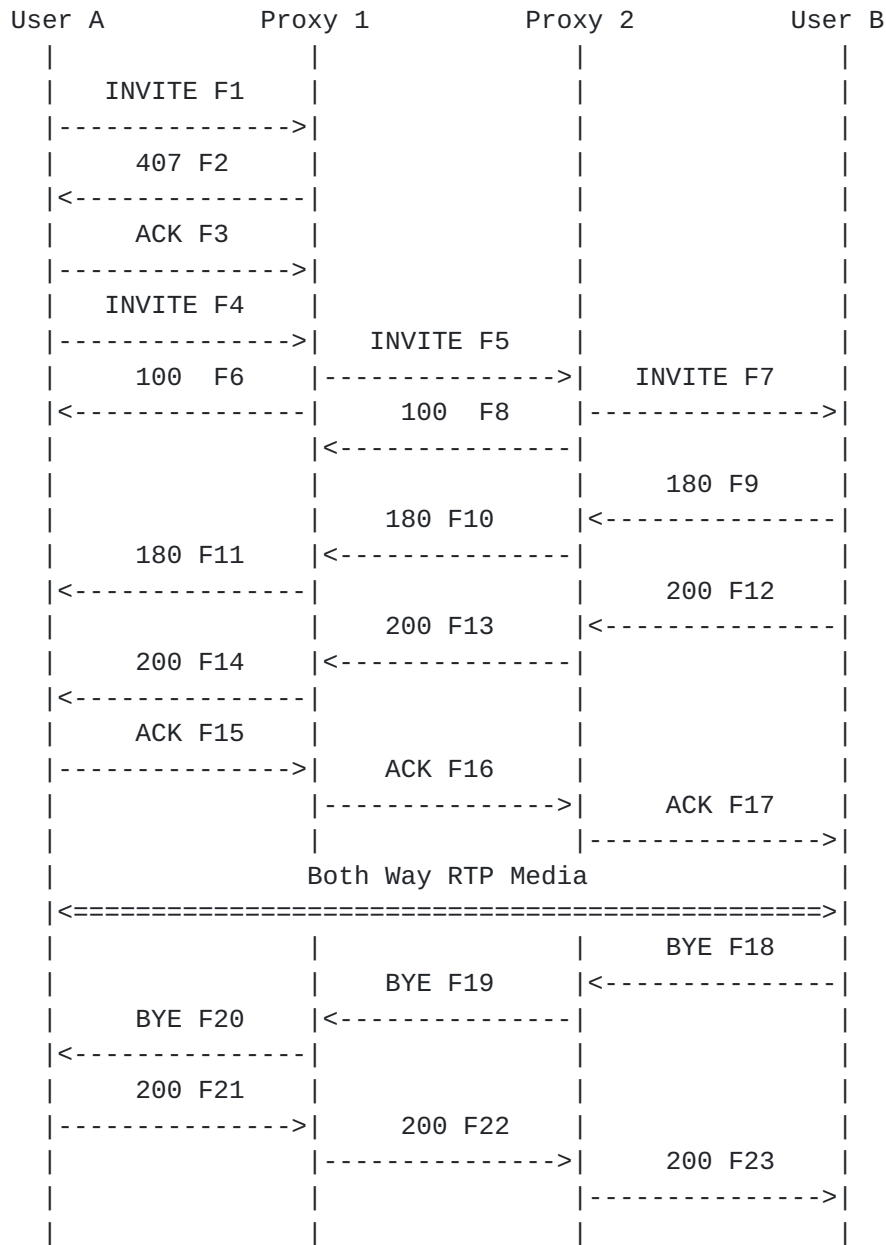

In this scenario, User A completes a call to User B using two proxies Proxy 1 and Proxy 2. The initial INVITE (F1) contains a pre-loaded Route header with the address of Proxy 1 (Proxy 1 is configured as a default outbound proxy for User A). The request does not contain the Authorization credentials Proxy 1 requires, so a 407 Proxy Authorization response is sent containing the challenge information. A new INVITE (F4) is then sent containing the correct credentials and the call proceeds. The call terminates when User B disconnects by initiating a BYE message.

Proxy 1 inserts a Record-Route header into the INVITE message to

ensure that it is present in all subsequent message exchanges. Proxy 2 also inserts itself into the Record-Route header. The ACK (F15) and BYE (F18) both have a Route header.

## Message Details

F1 INVITE A -> Proxy 1

```
INVITE sip:UserB@biloxi.com SIP/2.0
Via: SIP/2.0/UDP client.atlanta.com:5060;branch=z9hG4bK74bf9
Max-Forwards: 70
Route: <sip:ss1.atlanta.com;lr>
From: BigGuy <sip:UserA@atlanta.com>;tag=9fxced76sl
To: LittleGuy <sip:UserB@biloxi.com>
Call-ID: 3848276298220188511@atlanta.com
CSeq: 1 INVITE
Contact: <sip:UserA@192.168.100.101>
Content-Type: application/sdp
Content-Length: 147
```

```
v=0
o=UserA 2890844526 2890844526 IN IP4 client.atlanta.com
s=-
c=IN IP4 192.168.100.101
t=0 0
m=audio 49172 RTP/AVP 0
a=rtpmap:0 PCMU/8000
```

/\* Proxy 1 challenges User A for authentication \*/

F2 407 Proxy Authorization Required Proxy 1 -> User A

```
SIP/2.0 407 Proxy Authorization Required
Via: SIP/2.0/UDP client.atlanta.com:5060;branch=z9hG4bK74bf9
;received=192.168.100.101
From: BigGuy <sip:UserA@atlanta.com>;tag=9fxced76sl
To: LittleGuy <sip:UserB@biloxi.com>;tag=3flal12sf
Call-ID: 3848276298220188511@atlanta.com
CSeq: 1 INVITE
Proxy-Authenticate: Digest realm="atlanta.com", qop="auth",
  nonce="f84f1cec41e6cbe5aea9c8e88d359",
  opaque="", stale=FALSE, algorithm=MD5
Content-Length: 0
```

F3 ACK A -> Proxy 1

```
ACK sip:UserB@biloxi.com SIP/2.0
Via: SIP/2.0/UDP client.atlanta.com:5060;branch=z9hG4bK74bf9
Max-Forwards: 70
```

From: BigGuy <sip:UserA@atlanta.com>;tag=9fxced76sl  
To: LittleGuy <sip:UserB@biloxi.com>;tag=3flal12sf

Johnston, et al.

Informational

[Page 20]



Call-ID: 3848276298220188511@atlanta.com  
CSeq: 1 ACK  
Content-Length: 0

/\* User A responds be re-sending the INVITE with authentication  
credentials in it. \*/

F4 INVITE A -> Proxy 1

INVITE sip:UserB@biloxi.com SIP/2.0  
Via: SIP/2.0/UDP client.atlanta.com:5060;branch=z9hG4bK74bf9  
Max-Forwards: 70  
Route: <sip:ss1.atlanta.com;lr>  
From: BigGuy <sip:UserA@atlanta.com>;tag=9fxced76s1  
To: LittleGuy <sip:UserB@biloxi.com>  
Call-ID: 3848276298220188511@atlanta.com  
CSeq: 2 INVITE  
Contact: <sip:UserA@192.168.100.101>  
Proxy-Authorization: Digest username="UserA", realm="atlanta.com",  
nonce="wf84f1ceczx41ae6cbe5aea9c8e88d359", opaque="",  
uri="sip:UserB@biloxi.com", response="42ce3cef44b22f50c6a6071bc8"  
Content-Type: application/sdp  
Content-Length: 147

v=0  
o=UserA 2890844526 2890844526 IN IP4 client.atlanta.com  
s=-  
c=IN IP4 192.168.100.101  
t=0 0  
m=audio 49172 RTP/AVP 0  
a=rtpmap:0 PCMU/8000

/\* Proxy 1 accepts the credentials and forwards the INVITE to Proxy  
2. Proxy 1 is assumed to have been authenticated by Proxy 2 using  
IPSec. Client for A prepares to receive data on port 49172 from the  
network. \*/

F5 INVITE Proxy 1 -> Proxy 2

INVITE sip:UserB@biloxi.com SIP/2.0  
Via: SIP/2.0/UDP ss1.atlanta.com:5060;branch=z9hG4bK2d4790.1  
Via: SIP/2.0/UDP client.atlanta.com:5060;branch=z9hG4bK74bf9  
;received=192.168.100.101  
Max-Forwards: 69  
Record-Route: <sip:ss1.atlanta.com;lr>  
From: BigGuy <sip:UserA@atlanta.com>;tag=9fxced76s1  
To: LittleGuy <sip:UserB@biloxi.com>  
Call-ID: 3848276298220188511@atlanta.com

CSeq: 2 INVITE

Contact: <sip:UserA@192.168.100.101>

Johnston, et al.

Informational

[Page 21]

Content-Type: application/sdp  
Content-Length: 147

v=0  
o=UserA 2890844526 2890844526 IN IP4 client.atlanta.com  
s=-  
c=IN IP4 192.168.100.101  
t=0 0  
m=audio 49172 RTP/AVP 0  
a=rtpmap:0 PCMU/8000

F6 100 Trying Proxy 1 -> User A

SIP/2.0 100 Trying  
Via: SIP/2.0/UDP client.atlanta.com:5060;branch=z9hG4bK74bf9  
;received=192.168.100.101  
From: BigGuy <sip:UserA@atlanta.com>;tag=9fxced76sl  
To: LittleGuy <sip:UserB@biloxi.com>  
Call-ID: 3848276298220188511@atlanta.com  
CSeq: 2 INVITE  
Content-Length: 0

F7 INVITE Proxy 2 -> B

INVITE sip:UserB@192.168.200.201 SIP/2.0  
Via: SIP/2.0/UDP ss2.biloxi.com:5060;branch=z9hG4bK721e418c4.1  
Via: SIP/2.0/UDP ss1.atlanta.com:5060;branch=z9hG4bK2d4790.1  
;received=192.168.255.111  
Via: SIP/2.0/UDP client.atlanta.com:5060;branch=z9hG4bK74bf9  
;received=192.168.100.101  
Max-Forwards: 68  
Record-Route: <sip:ss2.biloxi.com;lr>, <sip:ss1.atlanta.com;lr>  
From: BigGuy <sip:UserA@atlanta.com>;tag=9fxced76sl  
To: LittleGuy <sip:UserB@biloxi.com>  
Call-ID: 3848276298220188511@atlanta.com  
CSeq: 2 INVITE  
Contact: <sip:UserA@192.168.100.101>  
Content-Type: application/sdp  
Content-Length: 147

v=0  
o=UserA 2890844526 2890844526 IN IP4 client.atlanta.com  
s=-  
c=IN IP4 192.168.100.101  
t=0 0  
m=audio 49172 RTP/AVP 0  
a=rtpmap:0 PCMU/8000

F8 100 Trying Proxy 2 -> Proxy 1

Johnston, et al.

Informational

[Page 22]

SIP/2.0 100 Trying

Via: SIP/2.0/UDP ss1.atlanta.com:5060;branch=z9hG4bK2d4790.1  
;received=192.168.255.111

Via: SIP/2.0/UDP client.atlanta.com:5060;branch=z9hG4bK74bf9  
;received=192.168.100.101

From: BigGuy <sip:UserA@atlanta.com>;tag=9fxced76sl

To: LittleGuy <sip:UserB@biloxi.com>

Call-ID: 3848276298220188511@atlanta.com

CSeq: 2 INVITE

Content-Length: 0

F9 180 Ringing B -> Proxy 2

SIP/2.0 180 Ringing

Via: SIP/2.0/UDP ss2.biloxi.com:5060;branch=z9hG4bK721e418c4.1  
;received=192.168.156.222

Via: SIP/2.0/UDP ss1.atlanta.com:5060;branch=z9hG4bK2d4790.1  
;received=192.168.255.111

Via: SIP/2.0/UDP client.atlanta.com:5060;branch=z9hG4bK74bf9  
;received=192.168.100.101

Record-Route: <sip:ss2.biloxi.com;lr>, <sip:ss1.atlanta.com;lr>

From: BigGuy <sip:UserA@atlanta.com>;tag=9fxced76sl

To: LittleGuy <sip:UserB@biloxi.com>;tag=314159

Call-ID: 3848276298220188511@atlanta.com

Contact: <sip:UserB@192.168.200.201>

CSeq: 2 INVITE

Content-Length: 0

F10 180 Ringing Proxy 2 -> Proxy 1

SIP/2.0 180 Ringing

Via: SIP/2.0/UDP ss1.atlanta.com:5060;branch=z9hG4bK2d4790.1  
;received=192.168.255.111

Via: SIP/2.0/UDP client.atlanta.com:5060;branch=z9hG4bK74bf9  
;received=192.168.100.101

Record-Route: <sip:ss2.biloxi.com;lr>, <sip:ss1.atlanta.com;lr>

From: BigGuy <sip:UserA@atlanta.com>;tag=9fxced76sl

To: LittleGuy <sip:UserB@biloxi.com>;tag=314159

Call-ID: 3848276298220188511@atlanta.com

Contact: <sip:UserB@192.168.200.201>

CSeq: 2 INVITE

Content-Length: 0

F11 180 Ringing Proxy 1 -> A

SIP/2.0 180 Ringing

Via: SIP/2.0/UDP client.atlanta.com:5060;branch=z9hG4bK74bf9  
;received=192.168.100.101

Johnston, et al.

Informational

[Page 23]

Record-Route: <sip:ss2.biloxi.com;lr>, <sip:ss1.atlanta.com;lr>  
From: BigGuy <sip:UserA@atlanta.com>;tag=9fxced76sl  
To: LittleGuy <sip:UserB@biloxi.com>;tag=314159  
Call-ID: 3848276298220188511@atlanta.com  
Contact: <sip:UserB@192.168.200.201>  
CSeq: 2 INVITE  
Content-Length: 0

F12 200 OK B -> Proxy 2

SIP/2.0 200 OK  
Via: SIP/2.0/UDP ss2.biloxi.com:5060;branch=z9hG4bK721e418c4.1  
;received=192.168.156.222  
Via: SIP/2.0/UDP ss1.atlanta.com:5060;branch=z9hG4bK2d4790.1  
;received=192.168.255.111  
Via: SIP/2.0/UDP client.atlanta.com:5060;branch=z9hG4bK74bf9  
;received=192.168.100.101  
Record-Route: <sip:ss2.biloxi.com;lr>, <sip:ss1.atlanta.com;lr>  
From: BigGuy <sip:UserA@atlanta.com>;tag=9fxced76sl  
To: LittleGuy <sip:UserB@biloxi.com>;tag=314159  
Call-ID: 3848276298220188511@atlanta.com  
CSeq: 2 INVITE  
Contact: <sip:UserB@192.168.200.201>  
Content-Type: application/sdp  
Content-Length: 145

v=0  
o=UserB 2890844527 2890844527 IN IP4 client.biloxi.com  
s=-  
c=IN IP4 192.168.200.201  
t=0 0  
m=audio 3456 RTP/AVP 0  
a=rtpmap:0 PCMU/8000

F13 200 OK Proxy 2 -> Proxy 1

SIP/2.0 200 OK  
Via: SIP/2.0/UDP ss1.atlanta.com:5060;branch=z9hG4bK2d4790.1  
;received=192.168.255.111  
Via: SIP/2.0/UDP client.atlanta.com:5060;branch=z9hG4bK74bf9  
;received=192.168.100.101  
Record-Route: <sip:ss2.biloxi.com;lr>, <sip:ss1.atlanta.com;lr>  
From: BigGuy <sip:UserA@atlanta.com>;tag=9fxced76sl  
To: LittleGuy <sip:UserB@biloxi.com>;tag=314159  
Call-ID: 3848276298220188511@atlanta.com  
CSeq: 2 INVITE  
Contact: <sip:UserB@192.168.200.201>

Content-Type: application/sdp  
Content-Length: 145

Johnston, et al.

Informational

[Page 24]



```
v=0
o=UserB 2890844527 2890844527 IN IP4 client.biloxi.com
s=-
c=IN IP4 192.168.200.201
t=0 0
m=audio 3456 RTP/AVP 0
a=rtpmap:0 PCMU/8000
```

F14 200 OK Proxy 1 -> A

```
SIP/2.0 200 OK
Via: SIP/2.0/UDP client.atlanta.com:5060;branch=z9hG4bK74bf9
;received=192.168.100.101
Record-Route: <sip:ss2.biloxi.com;lr>, <sip:ss1.atlanta.com;lr>
From: BigGuy <sip:UserA@atlanta.com>;tag=9fxcde76sl
To: LittleGuy <sip:UserB@biloxi.com>;tag=314159
Call-ID: 3848276298220188511@atlanta.com
CSeq: 2 INVITE
Contact: <sip:UserB@192.168.200.201>
Content-Type: application/sdp
Content-Length: 145
```

```
v=0
o=UserB 2890844527 2890844527 IN IP4 client.biloxi.com
s=-
c=IN IP4 192.168.200.201
t=0 0
m=audio 3456 RTP/AVP 0
a=rtpmap:0 PCMU/8000
```

F15 ACK A -> Proxy 1

```
ACK sip:UserB@192.168.200.201 SIP/2.0
Via: SIP/2.0/UDP client.atlanta.com:5060;branch=z9hG4bK74bf9
Max-Forwards: 70
Route: <sip:ss1.atlanta.com;lr>, <sip:ss2.biloxi.com;lr>
From: BigGuy <sip:UserA@atlanta.com>;tag=9fxcde76sl
To: LittleGuy <sip:UserB@biloxi.com>;tag=314159
Call-ID: 3848276298220188511@atlanta.com
CSeq: 2 ACK
Content-Length: 0
```

F16 ACK Proxy 1 -> Proxy 2

```
ACK sip:UserB@192.168.200.201 SIP/2.0
Via: SIP/2.0/UDP ss1.atlanta.com:5060;branch=z9hG4bK2d4790.1
Via: SIP/2.0/UDP client.atlanta.com:5060;branch=z9hG4bK74bf9
```

;received=192.168.100.101  
Max-Forwards: 69

Johnston, et al.

Informational

[Page 25]

```
Route: <sip:ss2.biloxi.com;lr>
From: BigGuy <sip:UserA@atlanta.com>;tag=9fxced76s1
To: LittleGuy <sip:UserB@biloxi.com>;tag=314159
Call-ID: 3848276298220188511@atlanta.com
CSeq: 2 ACK
Content-Length: 0
```

F17 ACK Proxy 2 -> B

```
ACK sip:UserB@192.168.200.201 SIP/2.0
Via: SIP/2.0/UDP ss2.biloxi.com:5060;branch=z9hG4bK721e418c4.1
Via: SIP/2.0/UDP ss1.atlanta.com:5060;branch=z9hG4bK2d4790.1
    ;received=192.168.255.111
Via: SIP/2.0/UDP client.atlanta.com:5060;branch=z9hG4bK74bf9
    ;received=192.168.100.101
Max-Forwards: 68
From: BigGuy <sip:UserA@atlanta.com>;tag=9fxced76s1
To: LittleGuy <sip:UserB@biloxi.com>;tag=314159
Call-ID: 3848276298220188511@atlanta.com
CSeq: 2 ACK
Content-Length: 0
```

/\* RTP streams are established between A and B \*/

/\* User B Hangs Up with User A. \*/

/\* Again, note that the CSeq is NOT 3. User A and User B maintain  
their own separate CSeq counts \*/

F18 BYE User B -> Proxy 2

```
BYE sip:UserA@192.168.100.101 SIP/2.0
Via: SIP/2.0/UDP client.biloxi.com:5060;branch=z9hG4bKnashds7
Max-Forwards: 70
Route: <sip:ss2.biloxi.com;lr>, <sip:ss1.atlanta.com;lr>
From: LittleGuy <sip:UserB@biloxi.com>;tag=314159
To: BigGuy <sip:UserA@atlanta.com>;tag=9fxced76s1
Call-ID: 3848276298220188511@atlanta.com
CSeq: 1 BYE
Content-Length: 0
```

F19 BYE Proxy 2 -> Proxy 1

```
BYE sip:UserA@192.168.100.101 SIP/2.0
Via: SIP/2.0/UDP ss2.biloxi.com:5060;branch=z9hG4bK721e418c4.1
Via: SIP/2.0/UDP client.biloxi.com:5060;branch=z9hG4bKnashds7
    ;received=192.168.200.201
```

Max-Forwards: 69

Route: <sip:ss1.atlanta.com;lr>

Johnston, et al.

Informational

[Page 26]

From: LittleGuy <sip:UserB@biloxi.com>;tag=314159  
To: BigGuy <sip:UserA@atlanta.com>;tag=9fxced76sl  
Call-ID: 3848276298220188511@atlanta.com  
CSeq: 1 BYE  
Content-Length: 0

F20 BYE Proxy 1 -> User A

BYE sip:UserA@192.168.100.101 SIP/2.0  
Via: SIP/2.0/UDP ss1.atlanta.com:5060;branch=z9hG4bK2d4790.1  
Via: SIP/2.0/UDP ss2.biloxi.com:5060;branch=z9hG4bK721e418c4.1  
;received=192.168.156.222  
Via: SIP/2.0/UDP client.biloxi.com:5060;branch=z9hG4bKnashds7  
;received=192.168.200.201  
Max-Forwards: 68  
From: LittleGuy <sip:UserB@biloxi.com>;tag=314159  
To: BigGuy <sip:UserA@atlanta.com>;tag=9fxced76sl  
Call-ID: 3848276298220188511@atlanta.com  
CSeq: 1 BYE  
Content-Length: 0

F21 200 OK User A -> Proxy 1

SIP/2.0 200 OK  
Via: SIP/2.0/UDP ss1.atlanta.com:5060;branch=z9hG4bK2d4790.1  
;received=192.168.255.111  
Via: SIP/2.0/UDP ss2.biloxi.com:5060;branch=z9hG4bK721e418c4.1  
;received=192.168.156.222  
Via: SIP/2.0/UDP client.biloxi.com:5060;branch=z9hG4bKnashds7  
;received=192.168.200.201  
From: LittleGuy <sip:UserB@biloxi.com>;tag=314159  
To: BigGuy <sip:UserA@atlanta.com>;tag=9fxced76sl  
Call-ID: 3848276298220188511@atlanta.com  
CSeq: 1 BYE  
Content-Length: 0

F22 200 OK Proxy 1 -> Proxy 2

SIP/2.0 200 OK  
Via: SIP/2.0/UDP ss2.biloxi.com:5060;branch=z9hG4bK721e418c4.1  
;received=192.168.156.222  
Via: SIP/2.0/UDP client.biloxi.com:5060;branch=z9hG4bKnashds7  
;received=192.168.100.101  
From: LittleGuy <sip:UserB@biloxi.com>;tag=314159  
To: BigGuy <sip:UserA@atlanta.com>;tag=9fxced76sl  
Call-ID: 3848276298220188511@atlanta.com  
CSeq: 1 BYE

Content-Length: 0

Johnston, et al.

Informational

[Page 27]

F23 200 OK Proxy 2 -> User B

SIP/2.0 200 OK

Via: SIP/2.0/UDP client.biloxi.com:5060;branch=z9hG4bKnashds7

;received=192.168.200.201

From: LittleGuy <sip:UserB@biloxi.com>;tag=314159

To: BigGuy <sip:UserA@atlanta.com>;tag=9fxced76sl

Call-ID: 3848276298220188511@atlanta.com

CSeq: 1 BYE

Content-Length: 0





**3.1.3 SIP to SIP with Multi Proxy Authentication**

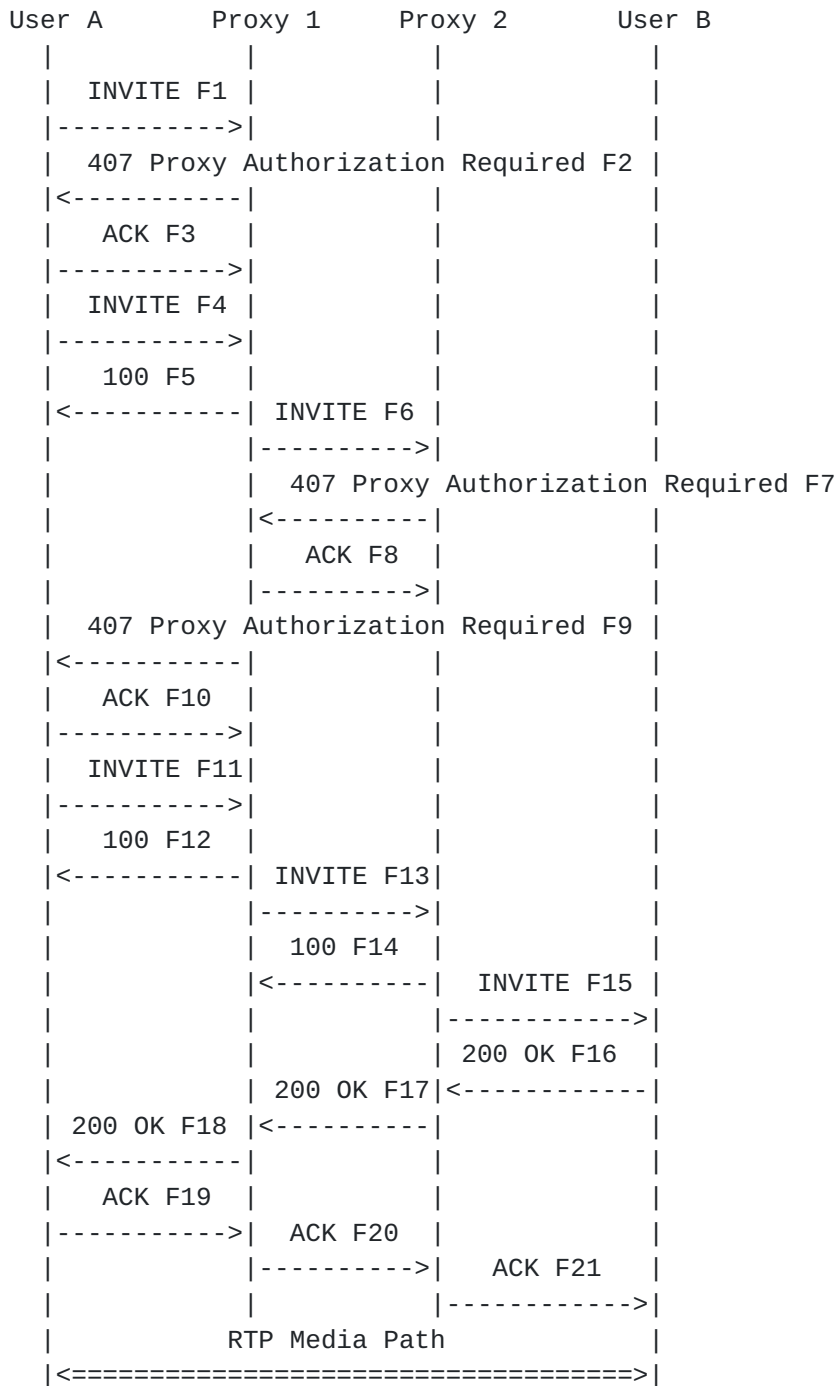

In this scenario, User A completes a call to User B using two proxies Proxy 1 and Proxy 2. User A has valid credentials in both domains. Since the initial INVITE (F1) does not contain the Authorization credentials Proxy 1 requires, so a 407 Proxy Authorization response is sent containing the challenge information. A new INVITE (F4) is then sent containing the correct credentials and the call proceeds after Proxy 2 challenges and receives valid

credentials. The call terminates when User B disconnects by initiating a BYE message.

Proxy 1 inserts a Record-Route header into the INVITE message to ensure that it is present in all subsequent message exchanges. Proxy 2 also inserts itself into the Record-Route header.

#### Message Details

F1 INVITE A -> Proxy 1

```
INVITE sip:UserB@biloxi.com SIP/2.0
Via: SIP/2.0/UDP client.atlanta.com:5060;branch=z9hG4bK74bf9
Max-Forwards: 70
Route: <sip:ss1.atlanta.com;lr>
From: BigGuy <sip:UserA@atlanta.com>;tag=9fxc76s1
To: LittleGuy <sip:UserB@biloxi.com>
Call-ID: 2xTb9vxSit55XU7p8@atlanta.com
CSeq: 1 INVITE
Contact: <sip:UserA@192.168.100.101>
Content-Type: application/sdp
Content-Length: 147
```

```
v=0
o=UserA 2890844526 2890844526 IN IP4 client.atlanta.com
s=-
c=IN IP4 192.168.100.101
t=0 0
m=audio 49172 RTP/AVP 0
a=rtpmap:0 PCMU/8000
```

/\* Proxy 1 challenges User A for authentication \*/

F2 407 Proxy Authorization Required Proxy 1 -> User A

```
SIP/2.0 407 Proxy Authorization Required
Via: SIP/2.0/UDP client.atlanta.com:5060;branch=z9hG4bK74bf9
;received=192.168.100.101
From: BigGuy <sip:UserA@atlanta.com>;tag=9fxc76s1
To: LittleGuy <sip:UserB@biloxi.com>;tag=876321
Call-ID: 2xTb9vxSit55XU7p8@atlanta.com
CSeq: 1 INVITE
Proxy-Authenticate: Digest realm="atlanta.com", qop="auth",
nonce="wf84f1cczx41ae6cbeaea9ce88d359",
opaque="", stale=FALSE, algorithm=MD5
Content-Length: 0
```

F3 ACK A -> Proxy 1

ACK sip:UserB@biloxi.com SIP/2.0

Johnston, et al.

Informational

[Page 30]

```
Max-Forwards: 70
Via: SIP/2.0/UDP client.atlanta.com:5060;branch=z9hG4bK74bf9
From: BigGuy <sip:UserA@atlanta.com>;tag=9fxced76sl
To: LittleGuy <sip:UserB@biloxi.com>;tag=876321
Call-ID: 2xTb9vxSit55XU7p8@atlanta.com
CSeq: 1 ACK
Content-Length: 0
```

```
/* User A responds be re-sending the INVITE with authentication
   credentials in it. The same Call-ID is used, so the CSeq is
   increased. */
```

```
F4 INVITE A -> Proxy 1
```

```
INVITE sip:UserB@biloxi.com SIP/2.0
Via: SIP/2.0/UDP client.atlanta.com:5060;branch=z9hG4bK74bf9
Max-Forwards: 70
Route: <sip:ss1.atlanta.com;lr>
From: BigGuy <sip:UserA@atlanta.com>;tag=9fxced76sl
To: LittleGuy <sip:UserB@biloxi.com>
Call-ID: 2xTb9vxSit55XU7p8@atlanta.com
CSeq: 2 INVITE
Contact: <sip:UserA@192.168.100.101>
Proxy-Authorization: Digest username="UserA", realm="atlanta.com",
  nonce="wf84f1ceczx41ae6cbe5aea9c8e88d359", opaque="",
  uri="sip:UserB@biloxi.com", response="42ce3cef44b22f50c6a6071bc8"
Content-Type: application/sdp
Content-Length: 147
```

```
v=0
o=UserA 2890844526 2890844526 IN IP4 client.atlanta.com
s=-
c=IN IP4 192.168.100.101
t=0 0
m=audio 49172 RTP/AVP 0
a=rtpmap:0 PCMU/8000
```

```
/* Proxy 1 accepts the credentials and forwards the INVITE to Proxy
   2. Proxy 1 is assumed to have been authenticated by Proxy 2 using
   IPSec. Client for A prepares to receive data on port 49172 from the
   network. */
```

```
F5 100 Trying Proxy 1 -> User A
```

```
SIP/2.0 100 Trying
Via: SIP/2.0/UDP client.atlanta.com:5060;branch=z9hG4bK74bf9
  ;received=192.168.100.101
From: BigGuy <sip:UserA@atlanta.com>;tag=9fxced76sl
```

To: LittleGuy <sip:UserB@biloxi.com>  
Call-ID: 2xTb9vXSit55XU7p8@atlanta.com

Johnston, et al.

Informational

[Page 31]

CSeq: 2 INVITE  
Content-Length: 0

F6 INVITE Proxy 1 -> Proxy 2

INVITE sip:UserB@biloxi.com SIP/2.0  
Via: SIP/2.0/UDP ss1.atlanta.com:5060;branch=z9hG4bK230f2.1  
Via: SIP/2.0/UDP client.atlanta.com:5060;branch=z9hG4bK74bf9  
;received=192.168.100.101  
Max-Forwards: 69  
Record-Route: <sip:ss1.atlanta.com;lr>  
From: BigGuy <sip:UserA@atlanta.com>;tag=9fxced76s1  
To: LittleGuy <sip:UserB@biloxi.com>  
Call-ID: 2xTb9vxSit55XU7p8@atlanta.com  
CSeq: 2 INVITE  
Contact: <sip:UserA@192.168.100.101>  
Content-Type: application/sdp  
Content-Length: 147

v=0  
o=UserA 2890844526 2890844526 IN IP4 client.atlanta.com  
s=-  
c=IN IP4 192.168.100.101  
t=0 0  
m=audio 49172 RTP/AVP 0  
a=rtpmap:0 PCMU/8000

/\* Proxy 2 challenges User A for authentication \*/

F7 407 Proxy Authorization Required Proxy 2 -> Proxy 1

SIP/2.0 407 Proxy Authorization Required  
Via: SIP/2.0/UDP ss1.atlanta.com:5060;branch=z9hG4bK230f2.1  
;received=192.168.255.111  
Via: SIP/2.0/UDP client.atlanta.com:5060;branch=z9hG4bK74bf9  
;received=192.168.100.101  
From: BigGuy <sip:UserA@atlanta.com>;tag=9fxced76s1  
To: LittleGuy <sip:UserB@biloxi.com>;tag=838209  
Call-ID: 2xTb9vxSit55XU7p8@atlanta.com  
CSeq: 2 INVITE  
Proxy-Authenticate: Digest realm="biloxi.com", qop="auth",  
nonce="c1e22c41ae6cbe5ae983a9c8e88d359",  
opaque="", stale=FALSE, algorithm=MD5  
Content-Length: 0

F8 ACK Proxy 1 -> Proxy 2

ACK sip:UserB@biloxi.com SIP/2.0

Via: SIP/2.0/UDP client.atlanta.com:5060;branch=z9hG4bK74bf9

Johnston, et al.

Informational

[Page 32]



Max-Forwards: 70  
From: BigGuy <sip:UserA@atlanta.com>;tag=9fxced76s1  
To: LittleGuy <sip:UserB@biloxi.com>;tag=838209  
Call-ID: 2xTb9vxSit55XU7p8@atlanta.com  
CSeq: 2 ACK  
Content-Length: 0

/\* Proxy 1 forwards the challenge to User A for authentication from  
Proxy 2 \*/

F9 407 Proxy Authorization Required Proxy 1 -> User A

SIP/2.0 407 Proxy Authorization Required  
Via: SIP/2.0/UDP client.atlanta.com:5060;branch=z9hG4bK74bf9  
;received=192.168.100.101  
From: BigGuy <sip:UserA@atlanta.com>;tag=9fxced76s1  
To: LittleGuy <sip:UserB@biloxi.com>;tag=838209  
Call-ID: 2xTb9vxSit55XU7p8@atlanta.com  
CSeq: 2 INVITE  
Proxy-Authenticate: Digest realm="biloxi.com", qop="auth",  
nonce="c1e22c41ae6cbe5ae983a9c8e88d359",  
opaque="", stale=FALSE, algorithm=MD5  
Content-Length: 0

F10 ACK User A -> Proxy 1

ACK sip:UserB@biloxi.com SIP/2.0  
Via: SIP/2.0/UDP client.atlanta.com:5060;branch=z9hG4bK74bf9  
Max-Forwards: 70  
From: BigGuy <sip:UserA@atlanta.com>;tag=9fxced76s1  
To: LittleGuy <sip:UserB@biloxi.com>;tag=838209  
Call-ID: 2xTb9vxSit55XU7p8@atlanta.com  
CSeq: 2 ACK  
Content-Length: 0

/\* User A responds by re-sending the INVITE with authentication  
credentials for Proxy 1 AND Proxy 2. \*/

F11 INVITE A -> Proxy 1

INVITE sip:UserB@biloxi.com SIP/2.0  
Via: SIP/2.0/UDP client.atlanta.com:5060;branch=z9hG4bK74bf9  
Max-Forwards: 70  
From: BigGuy <sip:UserA@atlanta.com>;tag=9fxced76s1  
To: LittleGuy <sip:UserB@biloxi.com>  
Call-ID: 2xTb9vxSit55XU7p8@atlanta.com  
CSeq: 3 INVITE

Contact: <sip:UserA@192.168.100.101>

Proxy-Authorization: Digest username="UserA", realm="atlanta.com",

Johnston, et al.

Informational

[Page 33]

```

    nonce="wf84f1ceczx41ae6cbe5aea9c8e88d359", opaque="",
    uri="sip:UserB@biloxi.com", response="42ce3cef44b22f50c6a6071bc8"
Proxy-Authorization: Digest username="UserA", realm="biloxi.com",
    nonce="c1e22c41ae6cbe5ae983a9c8e88d359", opaque="",
    uri="sip:UserB@biloxi.com", response="f44ab22f150c6a56071bce8"
Content-Type: application/sdp
Content-Length: 147

```

```

v=0
o=UserA 2890844526 2890844526 IN IP4 client.atlanta.com
s=-
c=IN IP4 192.168.100.101
t=0 0
m=audio 49172 RTP/AVP 0
a=rtpmap:0 PCMU/8000

```

```

/* Proxy 1 finds its credentials and authorizes User A, forwarding
the INVITE to Proxy. */

```

F12 100 Trying Proxy 1 -> User A

```

SIP/2.0 100 Trying
Via: SIP/2.0/UDP client.atlanta.com:5060;branch=z9hG4bK74bf9
    ;received=192.168.100.101
From: BigGuy <sip:UserA@atlanta.com>;tag=9fxced76sl
To: LittleGuy <sip:UserB@biloxi.com>
Call-ID: 2xTb9vxSit55XU7p8@atlanta.com
CSeq: 3 INVITE
Content-Length: 0

```

F13 INVITE Proxy 1 -> Proxy 2

```

INVITE sip:UserB@biloxi.com SIP/2.0
Via: SIP/2.0/UDP ss1.atlanta.com:5060;branch=z9hG4bK230f2.1
Via: SIP/2.0/UDP client.atlanta.com:5060;branch=z9hG4bK74bf9
    ;received=192.168.100.101
Max-Forwards: 69
Record-Route: <sip:ss1.atlanta.com;lr>
From: BigGuy <sip:UserA@atlanta.com>;tag=9fxced76sl
To: LittleGuy <sip:UserB@biloxi.com>
Call-ID: 2xTb9vxSit55XU7p8@atlanta.com
CSeq: 3 INVITE
Contact: <sip:UserA@192.168.100.101>
Proxy-Authorization: Digest username="UserA", realm="biloxi.com",
    nonce="c1e22c41ae6cbe5ae983a9c8e88d359", opaque="",
    uri="sip:UserB@biloxi.com", response="f44ab22f150c6a56071bce8"
Content-Type: application/sdp

```

Content-Length: 147

Johnston, et al.

Informational

[Page 34]

```
v=0
o=UserA 2890844526 2890844526 IN IP4 client.atlanta.com
s=-
c=IN IP4 192.168.100.101
t=0 0
m=audio 49172 RTP/AVP 0
a=rtpmap:0 PCMU/8000
```

```
/* Proxy 2 finds its credentials and authorizes User A, forwarding
the INVITE to User B. */
```

```
F14 100 Trying Proxy 2 -> Proxy 1
```

```
SIP/2.0 100 Trying
Via: SIP/2.0/UDP ss1.atlanta.com:5060;branch=z9hG4bK230f2.1
;received=192.168.255.111
Via: SIP/2.0/UDP client.atlanta.com:5060;branch=z9hG4bK74bf9
;received=192.168.100.101
From: BigGuy <sip:UserA@atlanta.com>;tag=9fxced76sl
To: LittleGuy <sip:UserB@biloxi.com>
Call-ID: 2xTb9vxSit55XU7p8@atlanta.com
CSeq: 3 INVITE
Content-Length: 0
```

```
F15 INVITE Proxy 2 -> User B
```

```
INVITE sip:UserB@192.168.200.201 SIP/2.0
Via: SIP/2.0/UDP ss2.biloxi.com:5060;branch=z9hG4bK31972.1
Via: SIP/2.0/UDP ss1.atlanta.com:5060;branch=z9hG4bK230f2.1
;received=192.168.255.111
Via: SIP/2.0/UDP client.atlanta.com:5060;branch=z9hG4bK74bf9
;received=192.168.100.101
Max-Forwards: 68
Record-Route: <sip:ss2.biloxi.com;lr>, <sip:ss1.atlanta.com;lr>
From: BigGuy <sip:UserA@atlanta.com>;tag=9fxced76sl
To: LittleGuy <sip:UserB@biloxi.com>
Call-ID: 2xTb9vxSit55XU7p8@atlanta.com
CSeq: 3 INVITE
Contact: <sip:UserA@192.168.100.101>
Content-Type: application/sdp
Content-Length: 147
```

```
v=0
o=UserA 2890844526 2890844526 IN IP4 client.atlanta.com
s=-
c=IN IP4 192.168.100.101
t=0 0
```

m=audio 49172 RTP/AVP 0  
a=rtpmap:0 PCMU/8000

Johnston, et al.

Informational

[Page 35]

```
/* User B answers the call immediately */
```

```
F16 200 OK User B -> Proxy 2
```

```
SIP/2.0 200 OK
```

```
Via: SIP/2.0/UDP ss2.biloxi.com:5060;branch=z9hG4bK31972.1
```

```
;received=192.168.156.222
```

```
Via: SIP/2.0/UDP ss1.atlanta.com:5060;branch=z9hG4bK230f2.1
```

```
;received=192.168.255.111
```

```
Via: SIP/2.0/UDP client.atlanta.com:5060;branch=z9hG4bK74bf9
```

```
;received=192.168.100.101
```

```
Record-Route: <sip:ss2.biloxi.com;lr>, <sip:ss1.atlanta.com;lr>
```

```
From: BigGuy <sip:UserA@atlanta.com>;tag=9fxced76sl
```

```
To: LittleGuy <sip:UserB@biloxi.com>;tag=9103874
```

```
Call-ID: 2xTb9vxSit55XU7p8@atlanta.com
```

```
CSeq: 3 INVITE
```

```
Contact: <sip:UserB@192.168.200.201>
```

```
Content-Type: application/sdp
```

```
Content-Length: 145
```

```
v=0
```

```
o=UserB 2890844527 2890844527 IN IP4 client.biloxi.com
```

```
s=-
```

```
c=IN IP4 192.168.200.201
```

```
t=0 0
```

```
m=audio 3456 RTP/AVP 0
```

```
a=rtpmap:0 PCMU/8000
```

```
F17 200 OK Proxy 2 -> Proxy 1
```

```
SIP/2.0 200 OK
```

```
Via: SIP/2.0/UDP ss1.atlanta.com:5060;branch=z9hG4bK230f2.1
```

```
;received=192.168.255.111
```

```
Via: SIP/2.0/UDP client.atlanta.com:5060;branch=z9hG4bK74bf9
```

```
;received=192.168.100.101
```

```
Record-Route: <sip:ss2.biloxi.com;lr>, <sip:ss1.atlanta.com;lr>
```

```
From: BigGuy <sip:UserA@atlanta.com>;tag=9fxced76sl
```

```
To: LittleGuy <sip:UserB@biloxi.com>;tag=9103874
```

```
Call-ID: 2xTb9vxSit55XU7p8@atlanta.com
```

```
CSeq: 3 INVITE
```

```
Contact: <sip:UserB@192.168.200.201>
```

```
Content-Type: application/sdp
```

```
Content-Length: 145
```

```
v=0
```

```
o=UserB 2890844527 2890844527 IN IP4 client.biloxi.com
```

```
s=-
```

c=IN IP4 192.168.200.201  
t=0 0  
m=audio 3456 RTP/AVP 0

Johnston, et al.

Informational

[Page 36]



a=rtpmap:0 PCMU/8000

F18 200 OK Proxy 1 -> User A

SIP/2.0 200 OK

Via: SIP/2.0/UDP client.atlanta.com:5060;branch=z9hG4bK74bf9  
;received=192.168.100.101

Record-Route: <sip:ss2.biloxi.com;lr>, <sip:ss1.atlanta.com;lr>

From: BigGuy <sip:UserA@atlanta.com>;tag=9fxced76sl

To: LittleGuy <sip:UserB@biloxi.com>;tag=9103874

Call-ID: 2xTb9vxSit55XU7p8@atlanta.com

CSeq: 3 INVITE

Contact: <sip:UserB@192.168.200.201>

Content-Type: application/sdp

Content-Length: 145

v=0

o=UserB 2890844527 2890844527 IN IP4 client.biloxi.com

s=-

c=IN IP4 192.168.200.201

t=0 0

m=audio 3456 RTP/AVP 0

a=rtpmap:0 PCMU/8000

F19 ACK User A -> Proxy 1

ACK sip:UserB@192.168.200.201 SIP/2.0

Via: SIP/2.0/UDP client.atlanta.com:5060;branch=z9hG4bK74bf9

Max-Forwards: 70

Route: <sip:ss1.atlanta.com;lr>, <sip:ss2.biloxi.com;lr>

From: BigGuy <sip:UserA@atlanta.com>;tag=9fxced76sl

To: LittleGuy <sip:UserB@biloxi.com>;tag=9103874

Call-ID: 2xTb9vxSit55XU7p8@atlanta.com

CSeq: 3 ACK

Content-Length: 0

F20 ACK Proxy 1 -> Proxy 2

ACK sip:UserB@192.168.200.201 SIP/2.0

Via: SIP/2.0/UDP ss1.atlanta.com:5060;branch=z9hG4bK230f2.1

Via: SIP/2.0/UDP client.atlanta.com:5060;branch=z9hG4bK74bf9  
;received=192.168.100.101

Max-Forwards: 69

Route: <sip:ss2.biloxi.com;lr>

From: BigGuy <sip:UserA@atlanta.com>;tag=9fxced76sl

To: LittleGuy <sip:UserB@biloxi.com>;tag=9103874

Call-ID: 2xTb9vxSit55XU7p8@atlanta.com

CSeq: 3 ACK

Contact: <sip:UserB@192.168.200.201>

Johnston, et al.

Informational

[Page 37]

Content-Length: 0

F21 ACK Proxy 2 -> User A

ACK sip:UserB@192.168.200.201 SIP/2.0

Via: SIP/2.0/UDP ss2.biloxi.com:5060;branch=z9hG4bK31972.1

Via: SIP/2.0/UDP ss1.atlanta.com:5060;branch=z9hG4bK230f2.1  
;received=192.168.255.111

Via: SIP/2.0/UDP client.atlanta.com:5060;branch=z9hG4bK74bf9  
;received=192.168.100.101

Max-Forwards: 68

From: BigGuy <sip:UserA@atlanta.com>;tag=9fxced76s1

To: LittleGuy <sip:UserB@biloxi.com>;tag=9103874

Call-ID: 2xTb9vxSit55XU7p8@atlanta.com

CSeq: 3 ACK

Contact: <sip:UserB@192.168.200.201>

Content-Length: 0



**3.1.4 Successful SIP to SIP with Proxy failure**

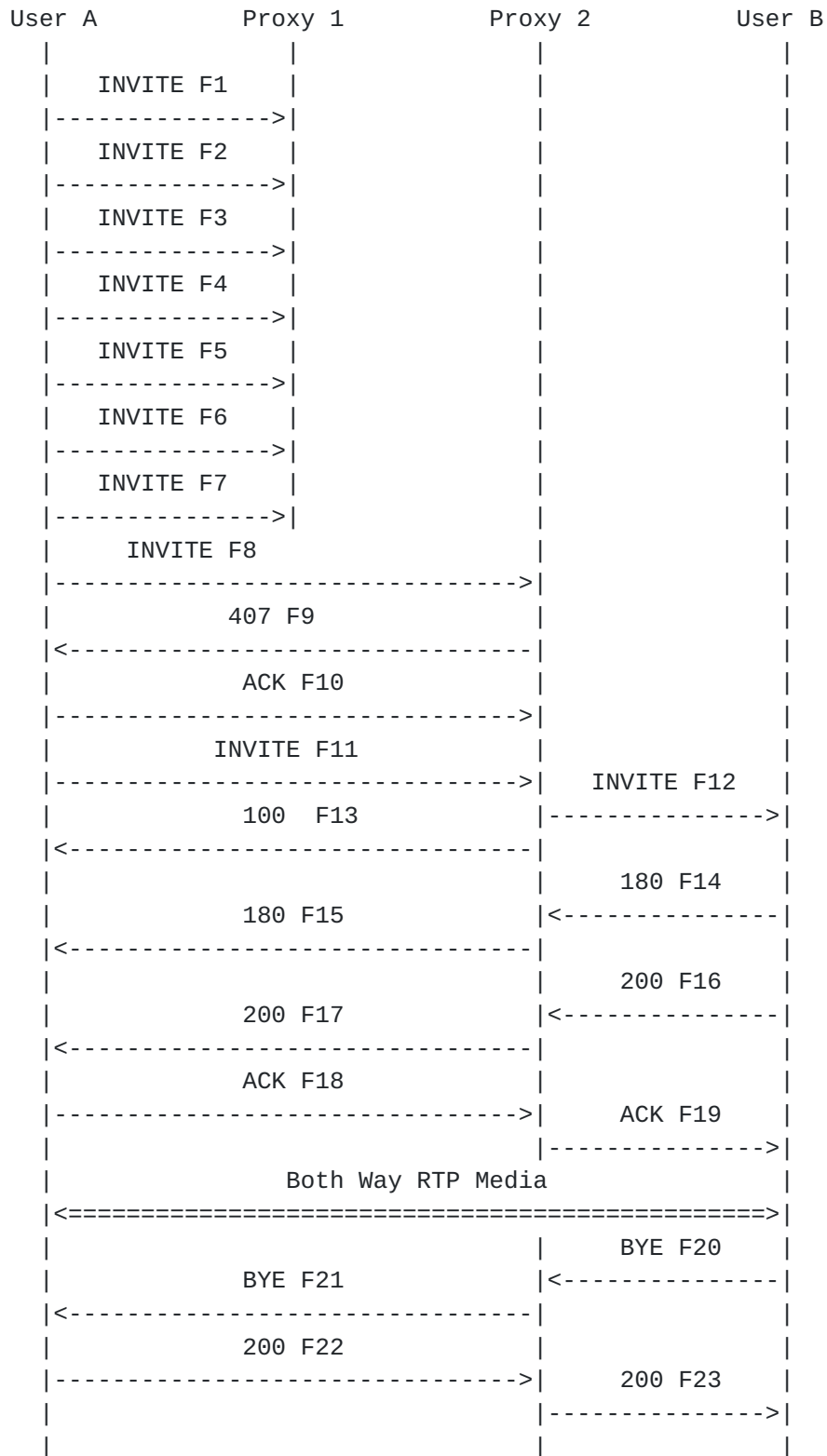

In this scenario, User A completes a call to User B via a Proxy

Server. User A is configured for a primary SIP Proxy Server Proxy 1 and a secondary SIP Proxy Server Proxy 2 (Or is able to use DNS SRV records to locate Proxy 1 and Proxy 2). User A has valid credentials

for both domains. Proxy 1 is out of service and does not respond to INVITES (it is reachable, but unresponsive). User A then completes the call to User B using Proxy 2.

#### Message Details

F1 INVITE A -> Proxy 1

```
INVITE sip:UserB@biloxi.com SIP/2.0
Via: SIP/2.0/UDP client.atlanta.com:5060;branch=z9hG4bK465bf9
Max-Forwards: 70
Route: <sip:ss1.atlanta.com;lr>
From: BigGuy <sip:UserA@atlanta.com>;tag=9fxced76s1
To: LittleGuy <sip:UserB@biloxi.com>
Call-ID: 2xTb9vxSit55XU7p8@atlanta.com
CSeq: 1 INVITE
Contact: <sip:UserA@192.168.100.101>
Content-Type: application/sdp
Content-Length: 147
```

```
v=0
o=UserA 2890844526 2890844526 IN IP4 client.atlanta.com
s=-
c=IN IP4 192.168.100.101
t=0 0
m=audio 49172 RTP/AVP 0
a=rtpmap:0 PCMU/8000
```

F2 INVITE A -> Proxy 1

Same as Message F1

F3 INVITE A -> Proxy 1

Same as Message F1

F4 INVITE A -> Proxy 1

Same as Message F1

F5 INVITE A -> Proxy 1

Same as Message F1

F6 INVITE A -> Proxy 1

Johnston, et al.

Informational

[Page 40]



Same as Message F1

F7 INVITE A -> Proxy 1

Same as Message F1

/\* User A gives up on the unresponsive proxy \*/

F8 INVITE A -> Proxy 2

```
INVITE sip:UserB@biloxi.com SIP/2.0
Via: SIP/2.0/UDP client.atlanta.com:5060;branch=z9hG4bK74bf9
Max-Forwards: 70
From: BigGuy <sip:UserA@atlanta.com>;tag=9fxced76sl
To: LittleGuy <sip:UserB@biloxi.com>
Call-ID: 4Fde34wkd11wsGFds3@atlanta.com
CSeq: 1 INVITE
Contact: <sip:UserA@192.168.100.101>
Content-Type: application/sdp
Content-Length: 147
```

```
v=0
o=UserA 2890844526 2890844526 IN IP4 client.atlanta.com
s=-
c=IN IP4 192.168.100.101
t=0 0
m=audio 49172 RTP/AVP 0
a=rtpmap:0 PCMU/8000
```

/\* Proxy 2 challenges User A for authentication \*/

F9 407 Proxy Authorization Required Proxy 2 -> User A

```
SIP/2.0 407 Proxy Authorization Required
Via: SIP/2.0/UDP client.atlanta.com:5060;branch=z9hG4bK74bf9
;received=192.168.100.101
From: BigGuy <sip:UserA@atlanta.com>;tag=9fxced76sl
To: LittleGuy <sip:UserB@biloxi.com>;tag=2421452
Call-ID: 4Fde34wkd11wsGFds3@atlanta.com
CSeq: 1 INVITE
Proxy-Authenticate: Digest realm="biloxi.com", qop="auth",
nonce="1ae6cbe5ea9c8e8df84fqnllec434a359",
opaque="", stale=FALSE, algorithm=MD5
Content-Length: 0
```

F10 ACK A -> Proxy 2

Johnston, et al.

Informational

[Page 41]

```
ACK sip:UserB@biloxi.com SIP/2.0
Via: SIP/2.0/UDP client.atlanta.com:5060;branch=z9hG4bK74bf9
Max-Forwards: 70
From: BigGuy <sip:UserA@atlanta.com>;tag=9fxced76sl
To: LittleGuy <sip:UserB@biloxi.com>;tag=2421452
Call-ID: 4Fde34wkd11wsGFds3@atlanta.com
CSeq: 1 ACK
Content-Length: 0
```

```
/* User A responds be re-sending the INVITE with authentication
credentials in it. */
```

```
F11 INVITE A -> Proxy 2
```

```
INVITE sip:UserB@biloxi.com SIP/2.0
Via: SIP/2.0/UDP client.atlanta.com:5060;branch=z9hG4bK74bf9
Max-Forwards: 70
From: BigGuy <sip:UserA@atlanta.com>;tag=9fxced76sl
To: LittleGuy <sip:UserB@biloxi.com>
Call-ID: 4Fde34wkd11wsGFds3@atlanta.com
CSeq: 2 INVITE
Contact: <sip:UserA@192.168.100.101>
Proxy-Authorization: Digest username="UserA", realm="biloxi.com",
  nonce="1ae6cbe5ea9c8e8df84fqnllec434a359", opaque="",
  uri="sip:UserB@biloxi.com",
  response="8a880c919d1a52f20a1593e228adf599"
Content-Type: application/sdp
Content-Length: 147
```

```
v=0
o=UserA 2890844526 2890844526 IN IP4 client.atlanta.com
s=-
c=IN IP4 192.168.100.101
t=0 0
m=audio 49172 RTP/AVP 0
a=rtpmap:0 PCMU/8000
```

```
/* Proxy 2 accepts the credentials and forwards the INVITE to User B.
Client for A prepares to receive data on port 49172 from the network.
*/
```

```
F12 INVITE Proxy 2 -> B
```

```
INVITE sip:UserB@192.168.200.201 SIP/2.0
Via: SIP/2.0/UDP ss2.biloxi.com:5060;branch=z9hG4bK721e418c4.1
Via: SIP/2.0/UDP client.atlanta.com:5060;branch=z9hG4bK74bf9
  ;received=192.168.100.101
```

Max-Forwards: 69

Record-Route: <sip:ss2.biloxi.com;lr>

Johnston, et al.

Informational

[Page 42]

From: BigGuy <sip:UserA@atlanta.com>;tag=9fxced76sl  
To: LittleGuy <sip:UserB@biloxi.com>  
Call-ID: 4Fde34wkd11wsGFDS3@atlanta.com  
CSeq: 2 INVITE  
Contact: <sip:UserA@192.168.100.101>  
Content-Type: application/sdp  
Content-Length: 147

v=0  
o=UserA 2890844526 2890844526 IN IP4 client.atlanta.com  
s=-  
c=IN IP4 192.168.100.101  
t=0 0  
m=audio 49172 RTP/AVP 0  
a=rtpmap:0 PCMU/8000

F13 100 Trying Proxy 2 -> User A

SIP/2.0 100 Trying  
Via: SIP/2.0/UDP client.atlanta.com:5060;branch=z9hG4bK74bf9  
;received=192.168.100.101  
From: BigGuy <sip:UserA@atlanta.com>;tag=9fxced76sl  
To: LittleGuy <sip:UserB@biloxi.com>  
Call-ID: 4Fde34wkd11wsGFDS3@atlanta.com  
CSeq: 2 INVITE  
Content-Length: 0

F14 180 Ringing B -> Proxy 2

SIP/2.0 180 Ringing  
Via: SIP/2.0/UDP ss2.biloxi.com:5060;branch=z9hG4bK721e418c4.1  
;received=192.168.156.222  
Via: SIP/2.0/UDP client.atlanta.com:5060;branch=z9hG4bK74bf9  
;received=192.168.100.101  
Record-Route: <sip:ss2.biloxi.com;lr>  
From: BigGuy <sip:UserA@atlanta.com>;tag=9fxced76sl  
To: LittleGuy <sip:UserB@biloxi.com>;tag=314159  
Call-ID: 4Fde34wkd11wsGFDS3@atlanta.com  
CSeq: 2 INVITE  
Contact: <sip:UserB@192.168.200.201>  
Content-Length: 0

F15 180 Ringing Proxy 2 -> A

SIP/2.0 180 Ringing  
Via: SIP/2.0/UDP client.atlanta.com:5060;branch=z9hG4bK74bf9  
;received=192.168.100.101

Record-Route: <sip:ss2.biloxi.com;lr>

From: BigGuy <sip:UserA@atlanta.com>;tag=9fxced76s1

Johnston, et al.

Informational

[Page 43]

To: LittleGuy <sip:UserB@biloxi.com>;tag=314159  
Call-ID: 4Fde34wkd11wsGFds3@atlanta.com  
CSeq: 2 INVITE  
Contact: <sip:UserB@192.168.200.201>  
Content-Length: 0

F16 200 OK B -> Proxy 2

SIP/2.0 200 OK  
Via: SIP/2.0/UDP ss2.biloxi.com:5060;branch=z9hG4bK721e418c4.1  
;received=192.168.156.222  
Via: SIP/2.0/UDP client.atlanta.com:5060;branch=z9hG4bK74bf9  
;received=192.168.100.101  
Record-Route: <sip:ss2.biloxi.com;lr>  
From: BigGuy <sip:UserA@atlanta.com>;tag=9fxced76sl  
To: LittleGuy <sip:UserB@biloxi.com>;tag=314159  
Call-ID: 4Fde34wkd11wsGFds3@atlanta.com  
CSeq: 2 INVITE  
Contact: <sip:UserB@192.168.200.201>  
Content-Type: application/sdp  
Content-Length: 145

v=0  
o=UserB 2890844527 2890844527 IN IP4 client.biloxi.com  
s=-  
c=IN IP4 192.168.200.201  
t=0 0  
m=audio 3456 RTP/AVP 0  
a=rtpmap:0 PCMU/8000

F17 200 OK Proxy 2 -> A

SIP/2.0 200 OK  
Via: SIP/2.0/UDP client.atlanta.com:5060;branch=z9hG4bK74bf9  
;received=192.168.100.101  
Record-Route: <sip:ss2.biloxi.com;lr>  
From: BigGuy <sip:UserA@atlanta.com>;tag=9fxced76sl  
To: LittleGuy <sip:UserB@biloxi.com>;tag=314159  
Call-ID: 4Fde34wkd11wsGFds3@atlanta.com  
CSeq: 2 INVITE  
Contact: <sip:UserB@192.168.200.201>  
Content-Type: application/sdp  
Content-Length: 145

v=0  
o=UserB 2890844527 2890844527 IN IP4 client.biloxi.com  
s=-

c=IN IP4 192.168.200.201  
t=0 0  
m=audio 3456 RTP/AVP 0

Johnston, et al.

Informational

[Page 44]



a=rtpmap:0 PCMU/8000

F18 ACK A -> Proxy 2

ACK sip:UserB@192.168.200.201 SIP/2.0  
Via: SIP/2.0/UDP client.atlanta.com:5060;branch=z9hG4bK74bf9  
Max-Forwards: 70  
Route: <sip:ss2.biloxi.com;lr>  
From: BigGuy <sip:UserA@atlanta.com>;tag=9fxced76s1  
To: LittleGuy <sip:UserB@biloxi.com>;tag=314159  
Call-ID: 4Fde34wkd11wsGFds3@atlanta.com  
CSeq: 2 ACK  
Content-Length: 0

F19 ACK Proxy 2 -> B

ACK sip:UserB@192.168.200.201 SIP/2.0  
Via: SIP/2.0/UDP ss2.biloxi.com:5060;branch=z9hG4bK721e418c4.1  
Via: SIP/2.0/UDP client.atlanta.com:5060;branch=z9hG4bK74bf9  
;received=192.168.100.101  
Max-Forwards: 69  
From: BigGuy <sip:UserA@atlanta.com>;tag=9fxced76s1  
To: LittleGuy <sip:UserB@biloxi.com>;tag=314159  
Call-ID: 4Fde34wkd11wsGFds3@atlanta.com  
CSeq: 2 ACK  
Content-Length: 0

/\* RTP streams are established between A and B \*/

/\* User B Hangs Up with User A. \*/

F20 BYE User B -> Proxy 2

BYE sip:UserA@192.168.100.101 SIP/2.0  
Via: SIP/2.0/UDP client.biloxi.com:5060;branch=z9hG4bKnashds7  
Max-Forwards: 70  
Route: <sip:ss2.biloxi.com;lr>  
From: LittleGuy <sip:UserB@biloxi.com>;tag=314159  
To: BigGuy <sip:UserA@atlanta.com>;tag=9fxced76s1  
Call-ID: 4Fde34wkd11wsGFds3@atlanta.com  
CSeq: 1 BYE  
Content-Length: 0

F21 BYE Proxy 2 -> User A

BYE sip:UserA@192.168.100.101 SIP/2.0

Via: SIP/2.0/UDP ss2.biloxi.com:5060;branch=z9hG4bK721e418c4.1

Via: SIP/2.0/UDP client.biloxi.com:5060;branch=z9hG4bKnashds7

Johnston, et al.

Informational

[Page 45]

```
;received=192.168.200.201
Max-Forwards: 69
From: LittleGuy <sip:UserB@biloxi.com>;tag=314159
To: BigGuy <sip:UserA@atlanta.com>;tag=9fxced76sl
Call-ID: 4Fde34wkd11wsGFDS3@atlanta.com
CSeq: 1 BYE
Content-Length: 0
```

```
F22 200 OK User A -> Proxy 2
```

```
SIP/2.0 200 OK
Via: SIP/2.0/UDP ss2.biloxi.com:5060;branch=z9hG4bK721e418c4.1
;received=192.168.156.222
Via: SIP/2.0/UDP client.biloxi.com:5060;branch=z9hG4bKnashds7
;received=192.168.200.201
From: LittleGuy <sip:UserB@biloxi.com>;tag=314159
To: BigGuy <sip:UserA@atlanta.com>;tag=9fxced76sl
Call-ID: 4Fde34wkd11wsGFDS3@atlanta.com
CSeq: 1 BYE
Content-Length: 0
```

```
F23 200 OK Proxy 2 -> User B
```

```
SIP/2.0 200 OK
Via: SIP/2.0/UDP client.biloxi.com:5060;branch=z9hG4bKnashds7
;received=192.168.200.201
From: LittleGuy <sip:UserB@biloxi.com>;tag=314159
To: BigGuy <sip:UserA@atlanta.com>;tag=9fxced76sl
Call-ID: 4Fde34wkd11wsGFDS3@atlanta.com
CSeq: 1 BYE
Content-Length: 0
```



**3.1.5 Successful SIP to SIP through SIP ALG**

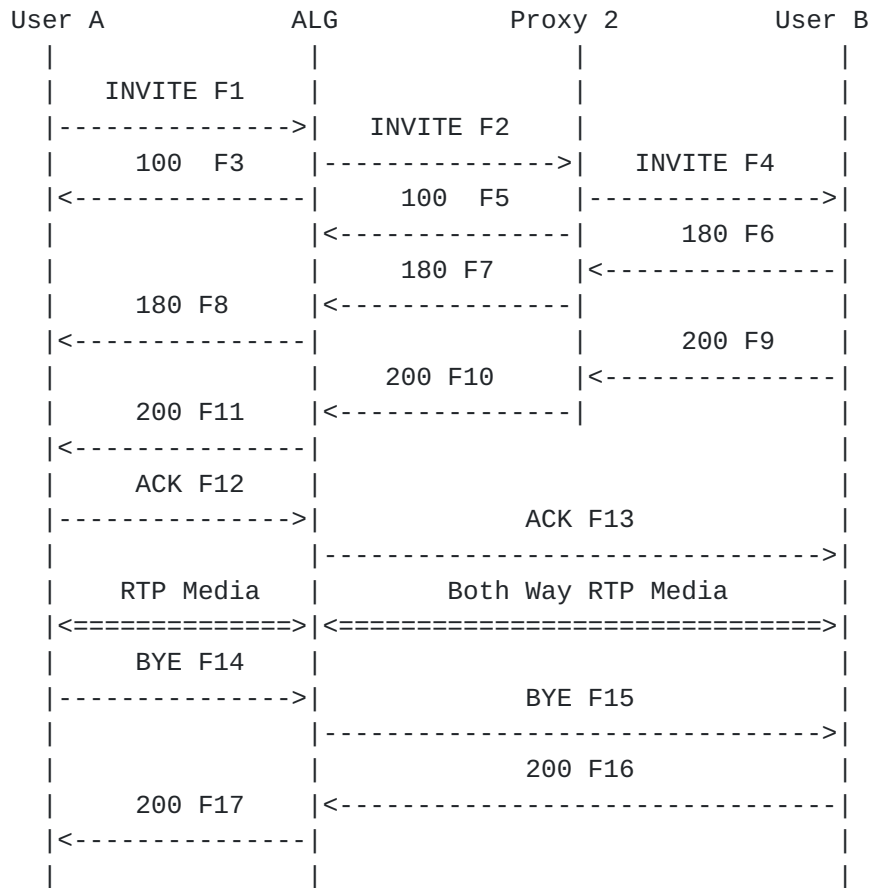

User A completes a call to User B through a ALG (Application Layer Gateway) and a SIP Proxy. The routing through the ALG is accomplished using a pre-loaded Route header in the INVITE F1. Note that the media stream setup is not end-to-end - the ALG terminates both media streams and bridges them. This is done by the ALG modifying the SDP in the INVITE (F1) and 200 OK (F10) messages, and possibly any 18x or ACK messages containing SDP.

In addition to firewall traversal, this Back-to-Back User Agent (B2BUA) could be used as part of an anonymizer service (in which all identifying information on User A would be removed), or to perform codec media conversion, such as mu-law to A-law conversion of PCM on an international call.

Also note that Proxy 2 does not Record-Route in this call flow.

Message Details

F1 INVITE A -> SIP ALG

INVITE sip:UserB@biloxi.com SIP/2.0  
Via: SIP/2.0/UDP client.atlanta.com:5060;branch=z9hG4bK74bf9  
Max-Forwards: 70

Johnston, et al.

Informational

[Page 47]

```
From: BigGuy <sip:UserA@atlanta.com>;tag=9fxc76s1
To: LittleGuy <sip:UserB@biloxi.com>
Call-ID: 2xTb9vxSit55XU7p8@atlanta.com
CSeq: 1 INVITE
Contact: <sip:UserA@192.168.100.101>
Route: <sip:alg1.atlanta.com;lr>
Proxy-Authorization: Digest username="UserA", realm="biloxi.com",
  nonce="85b4f1cen4341ae6cbe5a3a9c8e88df9", opaque="",
  uri="sip:UserB@biloxi.com",
  response="b3f392f9218a328b9294076d708e6815"
Content-Type: application/sdp
Content-Length: 147
```

```
v=0
o=UserA 2890844526 2890844526 IN IP4 client.atlanta.com
s=-
c=IN IP4 192.168.100.101
t=0 0
m=audio 49172 RTP/AVP 0
a=rtpmap:0 PCMU/8000
```

```
/* Client for A prepares to receive data on port 49172 from the
network. */
```

```
F2 INVITE SIP ALG -> Proxy 2
```

```
INVITE sip:UserB@biloxi.com SIP/2.0
Via: SIP/2.0/UDP alg1.atlanta.com:5060;branch=z9hG4bK739578.1
Via: SIP/2.0/UDP client.atlanta.com:5060;branch=z9hG4bK74bf9
  ;received=192.168.100.101
Max-Forwards: 69
Record-Route: <sip:alg1.atlanta.com;lr>
From: BigGuy <sip:UserA@atlanta.com>;tag=9fxc76s1
To: LittleGuy <sip:UserB@biloxi.com>
Call-ID: 2xTb9vxSit55XU7p8@atlanta.com
CSeq: 1 INVITE
Contact: <sip:UserA@192.168.100.101>
Proxy-Authorization: Digest username="UserA", realm="biloxi.com",
  nonce="85b4f1cen4341ae6cbe5a3a9c8e88df9", opaque="",
  uri="sip:UserB@biloxi.com",
  response="b3f392f9218a328b9294076d708e6815"
Content-Type: application/sdp
Content-Length: 146
```

```
v=0
o=UserA 2890844526 2890844526 IN IP4 client.atlanta.com
s=-
c=IN IP4 192.168.255.128
```

t=0 0  
m=audio 2000 RTP/AVP 0  
a=rtpmap:0 PCMU/8000

Johnston, et al.

Informational

[Page 48]



F3 100 Trying SIP ALG -> A

```
SIP/2.0 100 Trying
Via: SIP/2.0/UDP client.atlanta.com:5060;branch=z9hG4bK74bf9
    ;received=192.168.100.101
From: BigGuy <sip:UserA@atlanta.com>;tag=9fxced76sl
To: LittleGuy <sip:UserB@biloxi.com>
Call-ID: 2xTb9vxSit55XU7p8@atlanta.com
CSeq: 1 INVITE
Content-Length: 0
```

/\* SIP ALG prepares to proxy data from port 192.168.255.128/2000 to 192.168.100.101/49172. Proxy 2 uses a Location Service function to determine where B is located. Based upon location analysis the call is forwarded to User B \*/

F4 INVITE Proxy 2 -> B

```
INVITE sip:UserB@192.168.200.201 SIP/2.0
Via: SIP/2.0/UDP ss2.biloxi.com:5060;branch=z9hG4bK2d4790.1
Via: SIP/2.0/UDP alg1.atlanta.com:5060;branch=z9hG4bK739578.1
    ;received=192.168.255.128
Via: SIP/2.0/UDP client.atlanta.com:5060;branch=z9hG4bK74bf9
    ;received=192.168.100.101
Max-Forwards: 68
Record-Route: <sip:alg1.atlanta.com;lr>
From: BigGuy <sip:UserA@atlanta.com>;tag=9fxced76sl
To: LittleGuy <sip:UserB@biloxi.com>
Call-ID: 2xTb9vxSit55XU7p8@atlanta.com
CSeq: 1 INVITE
Contact: <sip:UserA@192.168.100.101>
Content-Type: application/sdp
Content-Length: 146
```

```
v=0
o=UserA 2890844526 2890844526 IN IP4 client.atlanta.com
s=-
c=IN IP4 192.168.255.128
t=0 0
m=audio 2000 RTP/AVP 0
a=rtpmap:0 PCMU/8000
```

F5 100 Trying Proxy 2 -> SIP ALG

```
SIP/2.0 100 Trying
Via: SIP/2.0/UDP alg1.atlanta.com:5060;branch=z9hG4bK739578.1
```

;received=192.168.255.128  
Via: SIP/2.0/UDP client.atlanta.com:5060;branch=z9hG4bK74bf9

Johnston, et al.

Informational

[Page 49]

;received=192.168.100.101  
From: BigGuy <sip:UserA@atlanta.com>;tag=9fxced76s1  
To: LittleGuy <sip:UserB@biloxi.com>  
Call-ID: 2xTb9vxSit55XU7p8@atlanta.com  
CSeq: 1 INVITE  
Content-Length: 0

F6 180 Ringing B -> Proxy 2

SIP/2.0 180 Ringing  
Via: SIP/2.0/UDP ss2.biloxi.com:5060;branch=z9hG4bK2d4790.1  
;received=192.168.156.222  
Via: SIP/2.0/UDP alg1.atlanta.com:5060;branch=z9hG4bK739578.1  
;received=192.168.255.128  
Via: SIP/2.0/UDP client.atlanta.com:5060;branch=z9hG4bK74bf9  
;received=192.168.100.101  
Record-Route: <sip:alg1.atlanta.com;lr>  
From: BigGuy <sip:UserA@atlanta.com>;tag=9fxced76s1  
To: LittleGuy <sip:UserB@biloxi.com>;tag=314159  
Call-ID: 2xTb9vxSit55XU7p8@atlanta.com  
CSeq: 1 INVITE  
Contact: <sip:UserB@192.168.200.201>  
Content-Length: 0

F7 180 Ringing Proxy 2 -> SIP ALG

SIP/2.0 180 Ringing  
Via: SIP/2.0/UDP alg1.atlanta.com:5060;branch=z9hG4bK739578.1  
;received=192.168.255.128  
Via: SIP/2.0/UDP client.atlanta.com:5060;branch=z9hG4bK74bf9  
;received=192.168.100.101  
Record-Route: <sip:alg1.atlanta.com;lr>  
From: BigGuy <sip:UserA@atlanta.com>;tag=9fxced76s1  
To: LittleGuy <sip:UserB@biloxi.com>;tag=314159  
Call-ID: 2xTb9vxSit55XU7p8@atlanta.com  
CSeq: 1 INVITE  
Contact: <sip:UserB@192.168.200.201>  
Content-Length: 0

F8 180 Ringing SIP ALG -> A

SIP/2.0 180 Ringing  
Via: SIP/2.0/UDP client.atlanta.com:5060;branch=z9hG4bK74bf9  
;received=192.168.100.101  
Record-Route: <sip:alg1.atlanta.com;lr>  
From: BigGuy <sip:UserA@atlanta.com>;tag=9fxced76s1  
To: LittleGuy <sip:UserB@biloxi.com>;tag=314159

Call-ID: 2xTb9vxSit55XU7p8@atlanta.com  
CSeq: 1 INVITE

Johnston, et al.

Informational

[Page 50]

Contact: <sip:UserB@192.168.200.201>  
Content-Length: 0

F9 200 OK B -> Proxy 2

SIP/2.0 200 OK  
Via: SIP/2.0/UDP ss2.biloxi.com:5060;branch=z9hG4bK2d4790.1  
;received=192.168.156.222  
Via: SIP/2.0/UDP alg1.atlanta.com:5060;branch=z9hG4bK739578.1  
;received=192.168.255.128  
Via: SIP/2.0/UDP client.atlanta.com:5060;branch=z9hG4bK74bf9  
;received=192.168.100.101  
Record-Route: <sip:alg1.atlanta.com;lr>  
From: BigGuy <sip:UserA@atlanta.com>;tag=9fxced76sl  
To: LittleGuy <sip:UserB@biloxi.com>;tag=314159  
Call-ID: 2xTb9vxSit55XU7p8@atlanta.com  
CSeq: 1 INVITE  
Contact: <sip:UserB@192.168.200.201>  
Content-Type: application/sdp  
Content-Length: 145

v=0  
o=UserB 2890844527 2890844527 IN IP4 client.biloxi.com  
s=-  
c=IN IP4 192.168.200.201  
t=0 0  
m=audio 3456 RTP/AVP 0  
a=rtpmap:0 PCMU/8000

F10 200 OK Proxy 2 -> SIP ALG

SIP/2.0 200 OK  
Via: SIP/2.0/UDP alg1.atlanta.com:5060;branch=z9hG4bK739578.1  
;received=192.168.255.128  
Via: SIP/2.0/UDP client.atlanta.com:5060;branch=z9hG4bK74bf9  
;received=192.168.100.101  
Record-Route: <sip:alg1.atlanta.com;lr>  
From: BigGuy <sip:UserA@atlanta.com>;tag=9fxced76sl  
To: LittleGuy <sip:UserB@biloxi.com>;tag=314159  
Call-ID: 2xTb9vxSit55XU7p8@atlanta.com  
CSeq: 1 INVITE  
Contact: <sip:UserB@192.168.200.201>  
Content-Type: application/sdp  
Content-Length: 145

v=0  
o=UserB 2890844527 2890844527 IN IP4 client.biloxi.com

S=-  
c=IN IP4 192.168.200.201  
t=0 0

Johnston, et al.

Informational

[Page 51]

m=audio 3456 RTP/AVP 0  
a=rtpmap:0 PCMU/8000

F11 200 OK SIP ALG -> A

SIP/2.0 200 OK  
Via: SIP/2.0/UDP client.atlanta.com:5060;branch=z9hG4bK74bf9  
;received=192.168.100.101  
Record-Route: <sip:alg1.atlanta.com;lr>  
From: BigGuy <sip:UserA@atlanta.com>;tag=9fxced76s1  
To: LittleGuy <sip:UserB@biloxi.com>;tag=314159  
Call-ID: 2xTb9vxSit55XU7p8@atlanta.com  
CSeq: 1 INVITE  
Contact: <sip:UserB@192.168.200.201>  
Content-Type: application/sdp  
Content-Length: 145

v=0  
o=UserB 2890844527 2890844527 IN IP4 client.biloxi.com  
s=-  
c=IN IP4 192.168.255.128  
t=0 0  
m=audio 1734 RTP/AVP 0  
a=rtpmap:0 PCMU/8000

/\* The ALG prepares to proxy packets from 192.168.255.128/  
1734 to 192.168.200.201/3456 \*/

F12 ACK A -> SIP ALG

ACK sip:UserB@192.168.200.201 SIP/2.0  
Via: SIP/2.0/UDP client.atlanta.com:5060;branch=z9hG4bK74bf9  
Max-Forwards: 70  
Route: <sip:alg1.atlanta.com;lr>  
From: BigGuy <sip:UserA@atlanta.com>;tag=9fxced76s1  
To: LittleGuy <sip:UserB@biloxi.com>;tag=314159  
Call-ID: 2xTb9vxSit55XU7p8@atlanta.com  
CSeq: 1 ACK  
Content-Length: 0

F13 ACK SIP ALG -> B

ACK sip:UserB@192.168.200.201 SIP/2.0  
Via: SIP/2.0/UDP alg1.atlanta.com:5060;branch=z9hG4bK739578.1  
Via: SIP/2.0/UDP client.atlanta.com:5060;branch=z9hG4bK74bf9  
;received=192.168.100.101  
Max-Forwards: 69

From: BigGuy <sip:UserA@atlanta.com>;tag=9fxced76s1  
To: LittleGuy <sip:UserB@biloxi.com>;tag=314159

Johnston, et al.

Informational

[Page 52]



Call-ID: 2xTb9vxSit55XU7p8@atlanta.com  
CSeq: 1 ACK  
Content-Length: 0

/\* RTP streams are established between A and the ALG and  
between the ALG and B\*/

/\* User A Hangs Up with User B. \*/

F14 BYE A -> SIP ALG

BYE sip:UserB@192.168.200.201 SIP/2.0  
Via: SIP/2.0/UDP client.atlanta.com:5060;branch=z9hG4bK74bf9  
Max-Forwards: 70  
Route: <sip:alg1.atlanta.com;lr>  
From: BigGuy <sip:UserA@atlanta.com>;tag=9fxced76s1  
To: LittleGuy <sip:UserB@biloxi.com>;tag=314159  
Call-ID: 2xTb9vxSit55XU7p8@atlanta.com  
CSeq: 2 BYE  
Content-Length: 0

F15 BYE SIP ALG -> B

BYE sip:UserB@192.168.200.201 SIP/2.0  
Via: SIP/2.0/UDP alg1.atlanta.com:5060;branch=z9hG4bK739578.1  
Via: SIP/2.0/UDP client.atlanta.com:5060;branch=z9hG4bK74bf9  
;received=192.168.100.101  
Max-Forwards: 69  
From: BigGuy <sip:UserA@atlanta.com>;tag=9fxced76s1  
To: LittleGuy <sip:UserB@biloxi.com>;tag=314159  
Call-ID: 2xTb9vxSit55XU7p8@atlanta.com  
CSeq: 2 BYE  
Content-Length: 0

F16 200 OK B -> SIP ALG

SIP/2.0 200 OK  
Via: SIP/2.0/UDP alg1.atlanta.com:5060;branch=z9hG4bK739578.1  
;received=192.168.255.128  
Via: SIP/2.0/UDP client.atlanta.com:5060;branch=z9hG4bK74bf9  
;received=192.168.100.101  
From: BigGuy <sip:UserA@atlanta.com>;tag=9fxced76s1  
To: LittleGuy <sip:UserB@biloxi.com>;tag=314159  
Call-ID: 2xTb9vxSit55XU7p8@atlanta.com  
CSeq: 2 BYE  
Content-Length: 0



F17 200 OK SIP ALG -> A

SIP/2.0 200 OK

Via: SIP/2.0/UDP client.atlanta.com:5060;branch=z9hG4bK74bf9  
;received=192.168.100.101

From: BigGuy <sip:UserA@atlanta.com>;tag=9fxced76sl

To: LittleGuy <sip:UserB@biloxi.com>;tag=314159

Call-ID: 2xTb9vxSit55XU7p8@atlanta.com

CSeq: 2 BYE

Content-Length: 0



**3.1.6 Successful SIP to SIP via Redirect and Proxy with SDP in ACK**

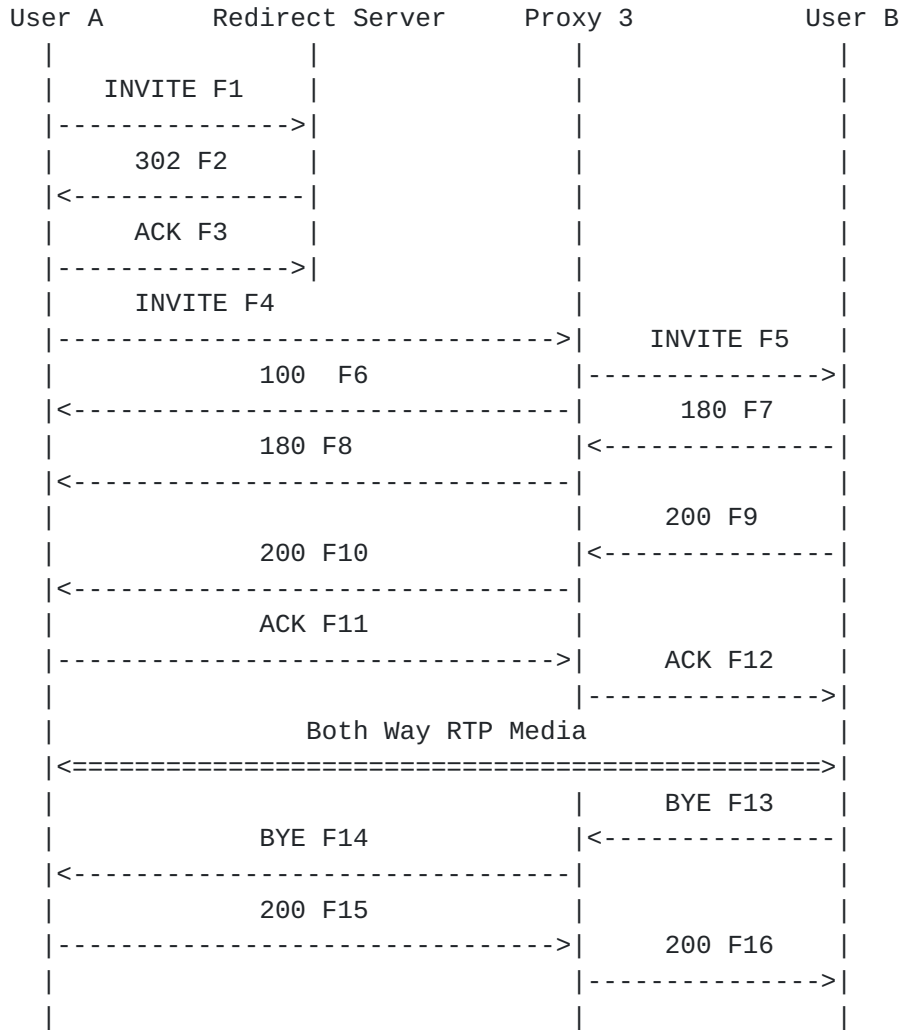

In this scenario, User A places a call to User B using first a Redirect server then a Proxy Server. The INVITE message is first sent to the Redirect Server. The Server returns a 302 Moved Temporarily response (F2) containing a Contact header with User B's current SIP address. User A then generates a new INVITE and sends to User B via the Proxy Server and the call proceeds normally. In this example, no SDP is present in the INVITE, so the SDP is carried in the ACK message.

The call is terminated when User B sends a BYE message.

Message Details

F1 INVITE A -> Redirect Server

INVITE sip:UserB@biloxi.com SIP/2.0  
Via: SIP/2.0/UDP client.atlanta.com:5060;branch=z9hG4bKbf9f44  
Max-Forwards: 70

Johnston, et al.

Informational

[Page 55]

From: BigGuy <sip:UserA@atlanta.com>;tag=9fxced76sl  
To: LittleGuy <sip:UserB@biloxi.com>  
Call-ID: 2xTb9vxSit55XU7p8@atlanta.com  
CSeq: 1 INVITE  
Contact: <sip:UserA@192.168.100.101>  
Content-Length: 0

F2 302 Moved Temporarily Redirect Proxy -> A

SIP/2.0 302 Moved Temporarily  
Via: SIP/2.0/UDP client.atlanta.com:5060;branch=z9hG4bKbf9f44  
;received=192.168.100.101  
From: BigGuy <sip:UserA@atlanta.com>;tag=9fxced76sl  
To: LittleGuy <sip:UserB@biloxi.com>;tag=53fHlqlQ2  
Call-ID: 2xTb9vxSit55XU7p8@atlanta.com  
CSeq: 1 INVITE  
Contact: sip:UserB@chicago.com  
Content-Length: 0

F3 ACK A -> Redirect Server

ACK sip:UserB@biloxi.com SIP/2.0  
Via: SIP/2.0/UDP client.atlanta.com:5060;branch=z9hG4bKbf9f44  
Max-Forwards: 70  
From: BigGuy <sip:UserA@atlanta.com>;tag=9fxced76sl  
To: LittleGuy <sip:UserB@biloxi.com>;tag=53fHlqlQ2  
Call-ID: 2xTb9vxSit55XU7p8@atlanta.com  
CSeq: 1 ACK  
Content-Length: 0

F4 INVITE A -> Proxy 3

INVITE sip:UserB@chicago.com SIP/2.0  
Via: SIP/2.0/UDP client.atlanta.com:5060;branch=z9hG4bK74bf9  
Max-Forwards: 70  
From: BigGuy <sip:UserA@atlanta.com>;tag=9fxced76sl  
To: LittleGuy <sip:UserB@biloxi.com>  
Call-ID: 2xTb9vxSit55XU7p8@atlanta.com  
CSeq: 2 INVITE  
Contact: <sip:UserA@192.168.100.101>  
Content-Length: 0

F5 INVITE Proxy 3 -> B

INVITE sip:UserB@192.168.200.100 SIP/2.0  
Via: SIP/2.0/UDP ss3.chicago.com:5060;branch=z9hG4bK721e418c4.1

Via: SIP/2.0/UDP client.atlanta.com:5060;branch=z9hG4bK74bf9  
;received=192.168.100.101

Johnston, et al.

Informational

[Page 56]



Max-Forwards: 69  
Record-Route: <sip:ss3.chicago.com;lr>  
From: BigGuy <sip:UserA@atlanta.com>;tag=9fxced76sl  
To: LittleGuy <sip:UserB@biloxi.com>  
Call-ID: 2xTb9vxSit55XU7p8@atlanta.com  
CSeq: 2 INVITE  
Contact: <sip:UserA@192.168.100.101>  
Content-Length: 0

F6 100 Trying Proxy 3 -> A

SIP/2.0 100 Trying  
Via: SIP/2.0/UDP client.atlanta.com:5060;branch=z9hG4bK74bf9  
;received=192.168.100.101  
From: BigGuy <sip:UserA@atlanta.com>;tag=9fxced76sl  
To: LittleGuy <sip:UserB@biloxi.com>  
Call-ID: 2xTb9vxSit55XU7p8@atlanta.com  
CSeq: 2 INVITE  
Content-Length: 0

F7 180 Ringing B -> Proxy 3

SIP/2.0 180 Ringing  
Via: SIP/2.0/UDP ss3.chicago.com:5060;branch=z9hG4bK721e418c4.1  
;received=192.168.182.333  
Via: SIP/2.0/UDP client.atlanta.com:5060;branch=z9hG4bK74bf9  
;received=192.168.100.101  
Record-Route: <sip:ss3.chicago.com;lr>  
From: BigGuy <sip:UserA@atlanta.com>;tag=9fxced76sl  
To: LittleGuy <sip:UserB@biloxi.com>;tag=314159  
Call-ID: 2xTb9vxSit55XU7p8@atlanta.com  
CSeq: 2 INVITE  
Contact: <sip:UserB@192.168.200.100>  
Content-Length: 0

F8 180 Ringing Proxy 3 -> A

SIP/2.0 180 Ringing  
Via: SIP/2.0/UDP client.atlanta.com:5060;branch=z9hG4bK74bf9  
;received=192.168.100.101  
Record-Route: <sip:ss3.chicago.com;lr>  
From: BigGuy <sip:UserA@atlanta.com>;tag=9fxced76sl  
To: LittleGuy <sip:UserB@biloxi.com>;tag=314159  
Call-ID: 2xTb9vxSit55XU7p8@atlanta.com  
CSeq: 2 INVITE  
Contact: <sip:UserB@192.168.200.100>  
Content-Length: 0



F9 200 OK B -> Proxy 3

SIP/2.0 200 OK

Via: SIP/2.0/UDP ss3.chicago.com:5060;branch=z9hG4bK721e418c4.1  
;received=192.168.182.333

Via: SIP/2.0/UDP client.atlanta.com:5060;branch=z9hG4bK74bf9  
;received=192.168.100.101

Record-Route: <sip:ss3.chicago.com;lr>

From: BigGuy <sip:UserA@atlanta.com>;tag=9fxced76s1

To: LittleGuy <sip:UserB@biloxi.com>;tag=314159

Call-ID: 2xTb9vxSit55XU7p8@atlanta.com

CSeq: 2 INVITE

Contact: <sip:UserB@192.168.200.100>

Content-Type: application/sdp

Content-Length: 146

v=0

o=UserB 2890844527 2890844527 IN IP4 client.chicago.com

s=-

c=IN IP4 192.168.200.100

t=0 0

m=audio 3456 RTP/AVP 0

a=rtpmap:0 PCMU/8000

F10 200 OK Proxy -> A

SIP/2.0 200 OK

Via: SIP/2.0/UDP client.atlanta.com:5060;branch=z9hG4bK74bf9  
;received=192.168.100.101

Record-Route: <sip:ss3.chicago.com;lr>

From: BigGuy <sip:UserA@atlanta.com>;tag=9fxced76s1

To: LittleGuy <sip:UserB@biloxi.com>;tag=314159

Call-ID: 2xTb9vxSit55XU7p8@atlanta.com

CSeq: 2 INVITE

Contact: <sip:UserB@192.168.200.100>

Content-Type: application/sdp

Content-Length: 146

v=0

o=UserB 2890844527 2890844527 IN IP4 client.chicago.com

s=-

c=IN IP4 192.168.200.100

t=0 0

m=audio 3456 RTP/AVP 0

a=rtpmap:0 PCMU/8000

/\* ACK contains SDP of A since none present in INVITE \*/

F11 ACK A -> Proxy 3

Johnston, et al.

Informational

[Page 58]

```
ACK sip:UserB@192.168.200.100 SIP/2.0
Via: SIP/2.0/UDP client.atlanta.com:5060;branch=z9hG4bK74bf9
Max-Forwards: 70
Route: <sip:ss3.chicago.com;lr>
From: BigGuy <sip:UserA@atlanta.com>;tag=9fxced76s1
To: LittleGuy <sip:UserB@biloxi.com>;tag=314159
Call-ID: 2xTb9vxSit55XU7p8@atlanta.com
CSeq: 2 ACK
Content-Type: application/sdp
Content-Length: 147
```

```
v=0
o=UserA 2890844526 2890844526 IN IP4 client.atlanta.com
s=-
c=IN IP4 192.168.100.101
t=0 0
m=audio 49172 RTP/AVP 0
a=rtpmap:0 PCMU/8000
```

F12 ACK Proxy 3 -> B

```
ACK sip:UserB@111.112.112.114 SIP/2.0
Via: SIP/2.0/UDP ss3.chicago.com:5060;branch=z9hG4bK721e418c4.1
Via: SIP/2.0/UDP client.atlanta.com:5060;branch=z9hG4bK74bf9
;received=192.168.100.101
Max-Forwards: 69
From: BigGuy <sip:UserA@atlanta.com>;tag=9fxced76s1
To: LittleGuy <sip:UserB@biloxi.com>;tag=314159
Call-ID: 2xTb9vxSit55XU7p8@atlanta.com
CSeq: 2 ACK
Content-Type: application/sdp
Content-Length: 147
```

```
v=0
o=UserA 2890844526 2890844526 IN IP4 client.atlanta.com
s=-
c=IN IP4 192.168.100.101
t=0 0
m=audio 49172 RTP/AVP 0
a=rtpmap:0 PCMU/8000
```

/\* RTP streams are established between A and B\*/

/\* User B Hangs Up with User A. \*/

F13 BYE B -> Proxy 3

```
BYE sip:UserA@192.168.100.101 SIP/2.0
Via: SIP/2.0/UDP client.chicago.com:5060;branch=z9hG4bKfgaw2
```

Max-Forwards: 70

Route: <sip:ss3.chicago.com;lr>

Johnston, et al.

Informational

[Page 59]

From: LittleGuy <sip:UserB@biloxi.com>;tag=314159  
To: BigGuy <sip:UserA@atlanta.com>;tag=9fxced76sl  
Call-ID: 2xTb9vxSit55XU7p8@atlanta.com  
CSeq: 1 BYE  
Content-Length: 0

F14 BYE Proxy 3 -> A

BYE sip:UserA@192.168.100.101 SIP/2.0  
Via: SIP/2.0/UDP ss3.chicago.com:5060;branch=z9hG4bK721e418c4.1  
;received=192.168.200.100  
Via: SIP/2.0/UDP client.chicago.com:5060;branch=z9hG4bKfgaw2  
Max-Forwards: 69  
From: LittleGuy <sip:UserB@biloxi.com>;tag=314159  
To: BigGuy <sip:UserA@atlanta.com>;tag=9fxced76sl  
Call-ID: 2xTb9vxSit55XU7p8@atlanta.com  
CSeq: 1 BYE  
Content-Length: 0

F15 200 OK A -> Proxy 3

SIP/2.0 200 OK  
Via: SIP/2.0/UDP ss3.chicago.com:5060;branch=z9hG4bK721e418c4.1  
;received=192.168.182.333  
Via: SIP/2.0/UDP client.chicago.com:5060;branch=z9hG4bKfgaw2  
;received=192.168.200.100  
From: LittleGuy <sip:UserB@biloxi.com>;tag=314159  
To: BigGuy <sip:UserA@atlanta.com>;tag=9fxced76sl  
Call-ID: 2xTb9vxSit55XU7p8@atlanta.com  
CSeq: 1 BYE  
Content-Length: 0

F16 200 OK Proxy 3 -> B

SIP/2.0 200 OK  
Via: SIP/2.0/UDP client.chicago.com:5060;branch=z9hG4bKfgaw2  
;received=192.168.200.100  
From: LittleGuy <sip:UserB@biloxi.com>;tag=314159  
To: BigGuy <sip:UserA@atlanta.com>;tag=9fxced76sl  
Call-ID: 2xTb9vxSit55XU7p8@atlanta.com  
CSeq: 1 BYE  
Content-Length: 0





3.1.7 Successful SIP to SIP with re-INVITE (IP Address Change)

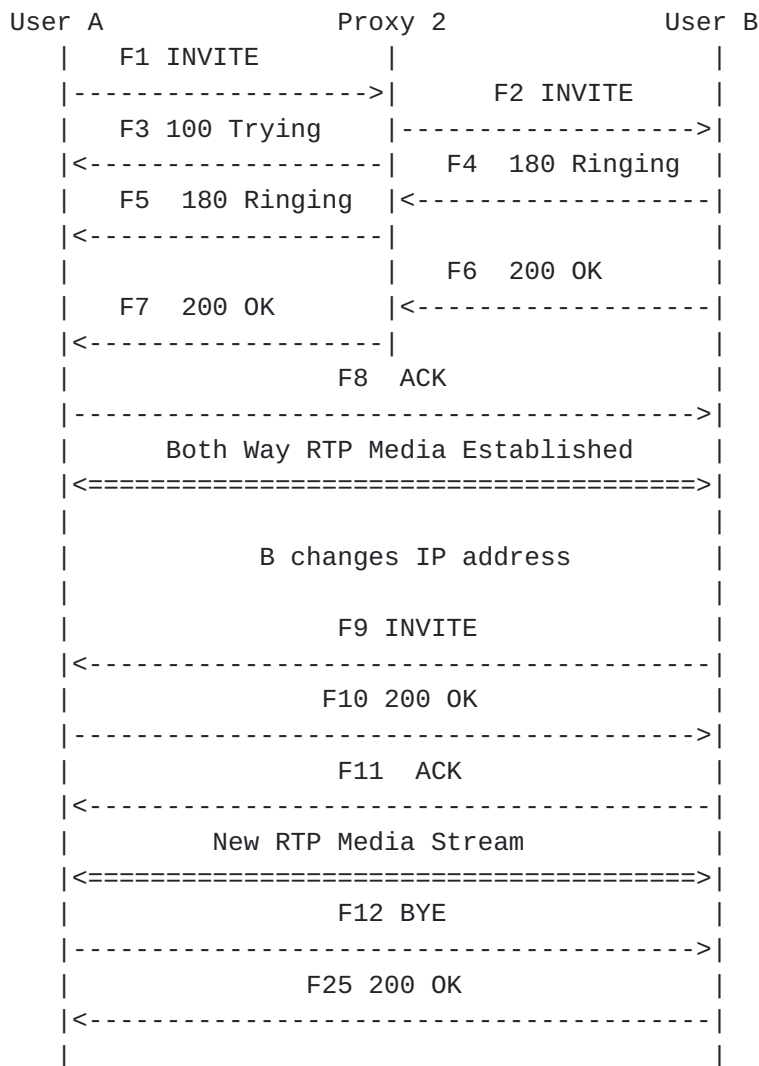

This example shows a session in which the media is changes midway through the session. When User B's IP address changes during the session, User B sends a re-INVITE containing a new Contact and SDP (version number incremented) information to A. In this flow, the proxy does not Record-Route so is not in the SIP messaging path after the initial exchange.

Message Details

F1 INVITE A -> Proxy 2

INVITE sip:UserB@biloxi.com SIP/2.0

Via: SIP/2.0/UDP client.atlanta.com:5060;branch=z9hG4bK74bf9

Max-Forwards: 70

From: BigGuy <sip:UserA@atlanta.com>;tag=9fxced76sl

To: LittleGuy <sip:UserB@biloxi.com>

Johnston, et al.

Informational

[Page 61]

Call-ID: 2xTb9vxSit55XU7p8@atlanta.com  
CSeq: 1 INVITE  
Contact: <sip:UserA@192.168.100.101>  
Content-Type: application/sdp  
Content-Length: 147

v=0  
o=UserA 2890844526 2890844526 IN IP4 client.atlanta.com  
s=-  
c=IN IP4 192.168.100.101  
t=0 0  
m=audio 49172 RTP/AVP 0  
a=rtpmap:0 PCMU/8000

F2 INVITE Proxy 2 -> B

INVITE sip:UserB@192.168.200.201 SIP/2.0  
Via: SIP/2.0/UDP ss2.biloxi.com:5060;branch=z9hG4bK2d4790.1  
Via: SIP/2.0/UDP client.atlanta.com:5060;branch=z9hG4bK74bf9  
;received=192.168.100.101  
Max-Forwards: 69  
From: BigGuy <sip:UserA@atlanta.com>;tag=9fxced76s1  
To: LittleGuy <sip:UserB@biloxi.com>  
Call-ID: 2xTb9vxSit55XU7p8@atlanta.com  
CSeq: 1 INVITE  
Contact: <sip:UserA@192.168.100.101>  
Content-Type: application/sdp  
Content-Length: 147

v=0  
o=UserA 2890844526 2890844526 IN IP4 client.atlanta.com  
s=-  
c=IN IP4 192.168.100.101  
t=0 0  
m=audio 49172 RTP/AVP 0  
a=rtpmap:0 PCMU/8000

F3 100 Trying Proxy 2 -> A

SIP/2.0 100 Trying  
Via: SIP/2.0/UDP client.atlanta.com:5060;branch=z9hG4bK74bf9  
;received=192.168.100.101  
From: BigGuy <sip:UserA@atlanta.com>;tag=9fxced76s1  
To: LittleGuy <sip:UserB@biloxi.com>  
Call-ID: 2xTb9vxSit55XU7p8@atlanta.com  
CSeq: 1 INVITE  
Content-Length: 0

F4 180 Ringing B -> Proxy 2

Johnston, et al.

Informational

[Page 62]

```
SIP/2.0 180 Ringing
Via: SIP/2.0/UDP ss2.biloxi.com:5060;branch=z9hG4bK2d4790.1
    ;received=192.168.156.222
Via: SIP/2.0/UDP client.atlanta.com:5060;branch=z9hG4bK74bf9
    ;received=192.168.100.101
From: BigGuy <sip:UserA@atlanta.com>;tag=9fxced76sl
To: LittleGuy <sip:UserB@biloxi.com>;tag=314159
Call-ID: 2xTb9vxSit55XU7p8@atlanta.com
CSeq: 1 INVITE
Contact: <sip:UserB@192.168.200.201>
Content-Length: 0
```

F5 180 Ringing Proxy 2 -> A

```
SIP/2.0 180 Ringing
Via: SIP/2.0/UDP client.atlanta.com:5060;branch=z9hG4bK74bf9
    ;received=192.168.100.101
From: BigGuy <sip:UserA@atlanta.com>;tag=9fxced76sl
To: LittleGuy <sip:UserB@biloxi.com>;tag=314159
Call-ID: 2xTb9vxSit55XU7p8@atlanta.com
CSeq: 1 INVITE
Contact: <sip:UserB@192.168.200.201>
Content-Length: 0
```

F6 200 OK B -> Proxy 2

```
SIP/2.0 200 OK
Via: SIP/2.0/UDP ss2.biloxi.com:5060;branch=z9hG4bK2d4790.1
    ;received=192.168.156.222
Via: SIP/2.0/UDP client.atlanta.com:5060;branch=z9hG4bK74bf9
    ;received=192.168.100.101
From: BigGuy <sip:UserA@atlanta.com>;tag=9fxced76sl
To: LittleGuy <sip:UserB@biloxi.com>;tag=314159
Call-ID: 2xTb9vxSit55XU7p8@atlanta.com
CSeq: 1 INVITE
Contact: <sip:UserB@192.168.200.201>
Content-Type: application/sdp
Content-Length: 145
```

```
v=0
o=UserB 2890844527 2890844527 IN IP4 client.biloxi.com
s=-
c=IN IP4 192.168.200.201
t=0 0
m=audio 3456 RTP/AVP 0
a=rtpmap:0 PCMU/8000
```

F7 200 OK Proxy 2 -> A

Johnston, et al.

Informational

[Page 63]

```
SIP/2.0 200 OK
Via: SIP/2.0/UDP client.atlanta.com:5060;branch=z9hG4bK74bf9
    ;received=192.168.100.101
From: BigGuy <sip:UserA@atlanta.com>;tag=9fxced76sl
To: LittleGuy <sip:UserB@biloxi.com>;tag=314159
Call-ID: 2xTb9vxSit55XU7p8@atlanta.com
CSeq: 1 INVITE
Contact: <sip:UserB@192.168.200.201>
Content-Type: application/sdp
Content-Length: 145
```

```
v=0
o=UserB 2890844527 2890844527 IN IP4 client.biloxi.com
s=-
c=IN IP4 192.168.200.201
t=0 0
m=audio 3456 RTP/AVP 0
a=rtpmap:0 PCMU/8000
```

F8 ACK A -> B

```
ACK sip:UserB@192.168.200.201 SIP/2.0
Via: SIP/2.0/UDP client.atlanta.com:5060;branch=z9hG4bK74bf9
Max-Forwards: 70
From: BigGuy <sip:UserA@atlanta.com>;tag=9fxced76sl
To: LittleGuy <sip:UserB@biloxi.com>;tag=314159
Call-ID: 2xTb9vxSit55XU7p8@atlanta.com
CSeq: 1 ACK
Content-Length: 0
```

/\* RTP streams are established between A and B \*/

/\* B changes IP address and re-INVITES A with new Contact and SDP \*/

F9 INVITE B -> A

```
INVITE sip:UserA@192.168.100.101 SIP/2.0
Via: SIP/2.0/UDP client.biloxi.com:5060;branch=z9hG4bK1k1d5l
Max-Forwards: 70
From: LittleGuy <sip:UserB@biloxi.com>;tag=314159
To: BigGuy <sip:UserA@atlanta.com>;tag=9fxced76sl
Call-ID: 2xTb9vxSit55XU7p8@atlanta.com
CSeq: 14 INVITE
Contact: <sip:UserB@192.168.200.100>
Content-Type: application/sdp
Content-Length: 147
```

v=0

Johnston, et al.

Informational

[Page 64]



```
o=UserB 2890844527 2890844528 IN IP4 client.chicago.com
s=-
c=IN IP4 192.168.200.100
t=0 0
m=audio 47172 RTP/AVP 0
a=rtpmap:0 PCMU/8000
```

F10 200 OK A ->B

```
SIP/2.0 200 OK
Via: SIP/2.0/UDP client.chicago.com:5060;branch=z9hG4bK1k1d51
;received=192.168.200.100
Max-Forwards: 70
From: LittleGuy <sip:UserB@biloxi.com>;tag=314159
To: BigGuy <sip:UserA@atlanta.com>;tag=9fxced76sl
Call-ID: 2xTb9vxSit55XU7p8@atlanta.com
CSeq: 14 INVITE
Contact: <sip:UserA@192.168.100.101>
Content-Type: application/sdp
Content-Length: 147
```

```
v=0
o=UserA 2890844526 2890844526 IN IP4 client.atlanta.com
s=-
c=IN IP4 192.168.100.101
t=0 0
m=audio 1000 RTP/AVP 0
a=rtpmap:0 PCMU/8000
```

F11 ACK B -> A

```
ACK sip:UserA@192.168.100.101 SIP/2.0
Via: SIP/2.0/UDP client.biloxi.com:5060;branch=z9hG4bK1k1d51
Max-Forwards: 70
From: LittleGuy <sip:UserB@biloxi.com>;tag=314159
To: BigGuy <sip:UserA@atlanta.com>;tag=9fxced76sl
Call-ID: 2xTb9vxSit55XU7p8@atlanta.com
CSeq: 14 ACK
Content-Length: 0
```

/\* New RTP stream established between A and B \*/

/\* A hangs up with B \*/

F12 BYE A -> B

```
BYE sip:UserB@192.168.200.100 SIP/2.0
```

Via: SIP/2.0/UDP client.atlanta.com:5060;branch=z9hG4bK74bf9  
Max-Forwards: 70

Johnston, et al.

Informational

[Page 65]

From: BigGuy <sip:UserA@atlanta.com>;tag=9fxc76s1  
To: LittleGuy <sip:UserB@biloxi.com>;tag=314159  
Call-ID: 2xTb9vxSit55XU7p8@atlanta.com  
CSeq: 2 BYE  
Content-Length: 0

F13 200 OK B -> A

SIP/2.0 200 OK  
Via: SIP/2.0/UDP client.atlanta.com:5060;branch=z9hG4bK74bf9  
;received=192.168.100.101  
Max-Forwards: 70  
From: BigGuy <sip:UserA@atlanta.com>;tag=9fxc76s1  
To: LittleGuy <sip:UserB@biloxi.com>;tag=314159  
Call-ID: 2xTb9vxSit55XU7p8@atlanta.com  
CSeq: 2 BYE  
Content-Length: 0



**3.2 Failure Scenarios**

**3.2.1 Unsuccessful SIP to SIP no answer**

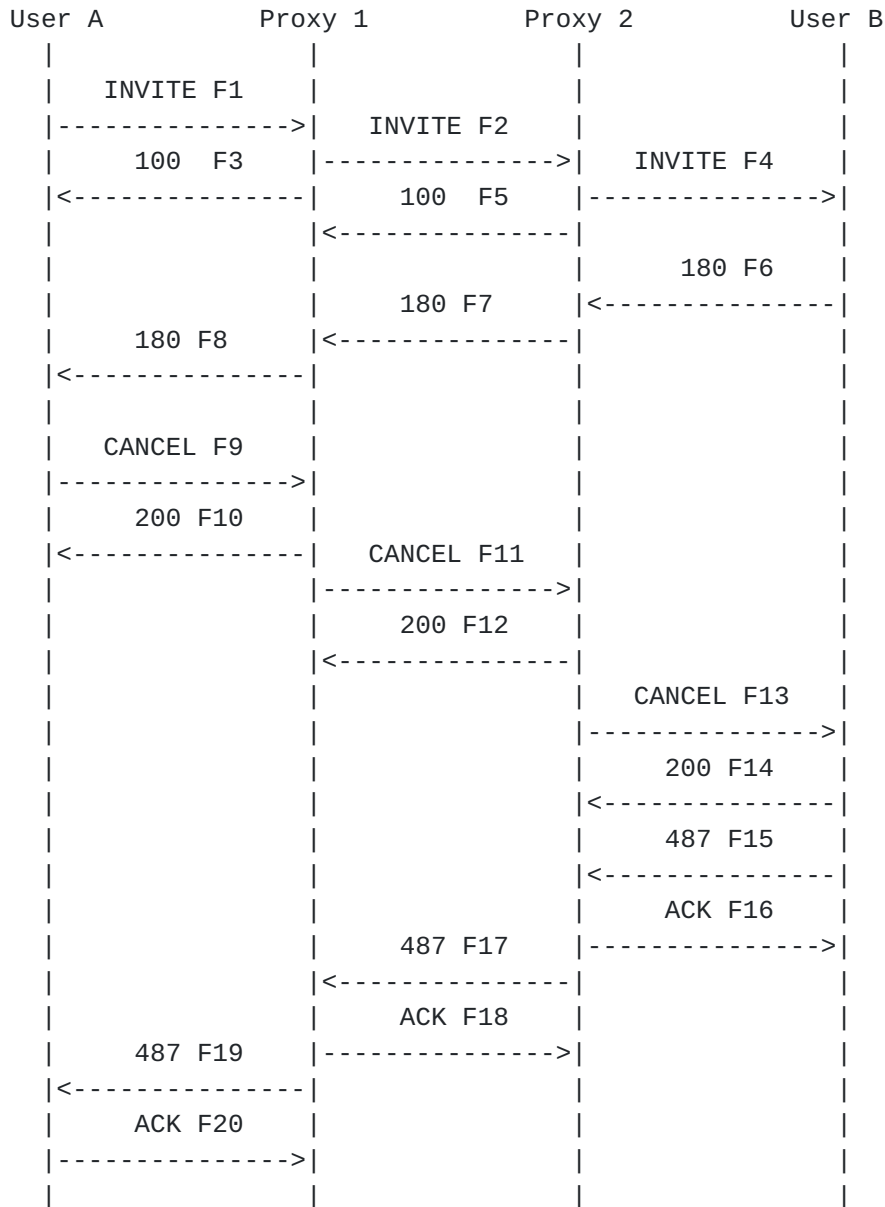

In this scenario, User A gives up on the call before User B answers (sends a 200 OK response). User A sends a CANCEL (F9) since no final response had been received from User B. If a 200 OK to the INVITE had crossed with the CANCEL, User A would have sent an ACK then a BYE to User B in order to properly terminate the call.

Note that the CANCEL message is acknowledged with a 200 OK on a hop by hop basis, rather than end to end.



## Message Details

F1 INVITE A -> Proxy 1

```
INVITE sip:UserB@biloxi.com SIP/2.0
Via: SIP/2.0/UDP client.atlanta.com:5060;branch=z9hG4bK74bf9
Max-Forwards: 70
Route: <sip:ss1.atlanta.com;lr>
From: BigGuy <sip:UserA@atlanta.com>;tag=9fxced76sl
To: LittleGuy <sip:UserB@biloxi.com>
Call-ID: 2xTb9vxSit55XU7p8@atlanta.com
CSeq: 1 INVITE
Contact: <sip:UserA@192.168.100.101>
Proxy-Authorization: Digest username="UserA", realm="atlanta.com",
  nonce="ze7k1ee88df84f1cec431ae6cbe5a359", opaque="",
  uri="sip:UserB@biloxi.com",
  response="b00b416324679d7e243f55708d44be7b"
Content-Type: application/sdp
Content-Length: 147
```

```
v=0
o=UserA 2890844526 2890844526 IN IP4 client.atlanta.com
s=-
c=IN IP4 192.168.100.101
t=0 0
m=audio 49172 RTP/AVP 0
a=rtpmap:0 PCMU/8000
```

```
/*Client for A prepares to receive data on port 49172 from the
network.*/
```

F2 INVITE Proxy 1 -> Proxy 2

```
INVITE sip:UserB@biloxi.com SIP/2.0
Via: SIP/2.0/UDP ss1.atlanta.com:5060;branch=z9hG4bK2d4790.1
Via: SIP/2.0/UDP client.atlanta.com:5060;branch=z9hG4bK74bf9
  ;received=192.168.100.101
Max-Forwards: 69
Record-Route: <sip:ss1.atlanta.com;lr>
From: BigGuy <sip:UserA@atlanta.com>;tag=9fxced76sl
To: LittleGuy <sip:UserB@biloxi.com>
Call-ID: 2xTb9vxSit55XU7p8@atlanta.com
CSeq: 1 INVITE
Contact: <sip:UserA@192.168.100.101>
Content-Type: application/sdp
Content-Length: 147
```

```
v=0
```

o=UserA 2890844526 2890844526 IN IP4 client.atlanta.com  
s=-

Johnston, et al.

Informational

[Page 68]



```
c=IN IP4 192.168.100.101
t=0 0
m=audio 49172 RTP/AVP 0
a=rtpmap:0 PCMU/8000
```

F3 100 Trying Proxy 1 -> A

```
SIP/2.0 100 Trying
Via: SIP/2.0/UDP client.atlanta.com:5060;branch=z9hG4bK74bf9
;received=192.168.100.101
From: BigGuy <sip:UserA@atlanta.com>;tag=9fxced76s1
To: LittleGuy <sip:UserB@biloxi.com>
Call-ID: 2xTb9vxSit55XU7p8@atlanta.com
CSeq: 1 INVITE
Content-Length: 0
```

F4 INVITE Proxy 2 -> B

```
INVITE sip:UserB@192.168.200.201 SIP/2.0
Via: SIP/2.0/UDP ss2.client.biloxi.com:5060;branch=z9hG4bK721e418c4.1
Via: SIP/2.0/UDP ss1.atlanta.com:5060;branch=z9hG4bK2d4790.1
;received=192.168.255.111
Via: SIP/2.0/UDP client.atlanta.com:5060;branch=z9hG4bK74bf9
;received=192.168.100.101
Record-Route: <sip:ss2.biloxi.com;lr>, <sip:ss1.atlanta.com;lr>
Max-Forwards: 68
From: BigGuy <sip:UserA@atlanta.com>;tag=9fxced76s1
To: LittleGuy <sip:UserB@biloxi.com>
Call-ID: 2xTb9vxSit55XU7p8@atlanta.com
CSeq: 1 INVITE
Contact: <sip:UserA@192.168.100.101>
Content-Type: application/sdp
Content-Length: 147
```

```
v=0
o=UserA 2890844526 2890844526 IN IP4 client.atlanta.com
s=-
c=IN IP4 192.168.100.101
t=0 0
m=audio 49172 RTP/AVP 0
a=rtpmap:0 PCMU/8000
```

F5 100 Trying Proxy 2 -> Proxy 1

```
SIP/2.0 100 Trying
Via: SIP/2.0/UDP ss1.atlanta.com:5060;branch=z9hG4bK2d4790.1
;received=192.168.255.111
```

Via: SIP/2.0/UDP client.atlanta.com:5060;branch=z9hG4bK74bf9  
;received=192.168.100.101

Johnston, et al.

Informational

[Page 69]

From: BigGuy <sip:UserA@atlanta.com>;tag=9fxced76sl  
To: LittleGuy <sip:UserB@biloxi.com>  
Call-ID: 2xTb9vxSit55XU7p8@atlanta.com  
CSeq: 1 INVITE  
Content-Length: 0

F6 180 Ringing B -> Proxy 2

SIP/2.0 180 Ringing  
Via: SIP/2.0/UDP ss2.client.biloxi.com:5060;branch=z9hG4bK721e418c4.1  
;received=192.168.156.222  
Via: SIP/2.0/UDP ss1.atlanta.com:5060;branch=z9hG4bK2d4790.1  
;received=192.168.255.111  
Via: SIP/2.0/UDP client.atlanta.com:5060;branch=z9hG4bK74bf9  
;received=192.168.100.101  
Record-Route: <sip:ss2.biloxi.com;lr>, <sip:ss1.atlanta.com;lr>  
From: BigGuy <sip:UserA@atlanta.com>;tag=9fxced76sl  
To: LittleGuy <sip:UserB@biloxi.com>;tag=314159  
Call-ID: 2xTb9vxSit55XU7p8@atlanta.com  
CSeq: 1 INVITE  
Contact: <sip:UserB@192.168.200.201>  
Content-Length: 0

F7 180 Ringing Proxy 2 -> Proxy 1

SIP/2.0 180 Ringing  
Via: SIP/2.0/UDP ss1.atlanta.com:5060;branch=z9hG4bK2d4790.1  
;received=192.168.255.111  
Via: SIP/2.0/UDP client.atlanta.com:5060;branch=z9hG4bK74bf9  
;received=192.168.100.101  
Record-Route: <sip:ss2.biloxi.com;lr>, <sip:ss1.atlanta.com;lr>  
From: BigGuy <sip:UserA@atlanta.com>;tag=9fxced76sl  
To: LittleGuy <sip:UserB@biloxi.com>;tag=314159  
Call-ID: 2xTb9vxSit55XU7p8@atlanta.com  
CSeq: 1 INVITE  
Contact: <sip:UserB@192.168.200.201>  
Content-Length: 0

F8 180 Ringing Proxy 1 -> A

SIP/2.0 180 Ringing  
Via: SIP/2.0/UDP client.atlanta.com:5060;branch=z9hG4bK74bf9  
;received=192.168.100.101  
Record-Route: <sip:ss2.biloxi.com;lr>, <sip:ss1.atlanta.com;lr>  
From: BigGuy <sip:UserA@atlanta.com>;tag=9fxced76sl  
To: LittleGuy <sip:UserB@biloxi.com>;tag=314159  
Call-ID: 2xTb9vxSit55XU7p8@atlanta.com

CSeq: 1 INVITE

Contact: <sip:UserB@192.168.200.201>

Johnston, et al.

Informational

[Page 70]

Content-Length: 0

F9 CANCEL A -> Proxy 1

CANCEL sip:UserB@biloxi.com SIP/2.0  
Via: SIP/2.0/UDP client.atlanta.com:5060;branch=z9hG4bK74bf9  
Max-Forwards: 70  
From: BigGuy <sip:UserA@atlanta.com>;tag=9fxced76s1  
To: LittleGuy <sip:UserB@biloxi.com>  
Call-ID: 2xTb9vxSit55XU7p8@atlanta.com  
CSeq: 1 CANCEL  
Content-Length: 0

F10 200 OK Proxy 1 -> A

SIP/2.0 200 OK  
Via: SIP/2.0/UDP client.atlanta.com:5060;branch=z9hG4bK74bf9  
;received=192.168.100.101  
From: BigGuy <sip:UserA@atlanta.com>;tag=9fxced76s1  
To: LittleGuy <sip:UserB@biloxi.com>  
Call-ID: 2xTb9vxSit55XU7p8@atlanta.com  
CSeq: 1 CANCEL  
Content-Length: 0

F11 CANCEL Proxy 1 -> Proxy 2

CANCEL sip:UserA@atlanta.com SIP/2.0  
Via: SIP/2.0/UDP ss1.atlanta.com:5060;branch=z9hG4bK2d4790.1  
Max-Forwards: 70  
From: BigGuy <sip:UserA@atlanta.com>;tag=9fxced76s1  
To: LittleGuy <sip:UserB@biloxi.com>  
Call-ID: 2xTb9vxSit55XU7p8@atlanta.com  
CSeq: 1 CANCEL  
Content-Length: 0

F12 200 OK Proxy 2 -> Proxy 1

SIP/2.0 200 OK  
Via: SIP/2.0/UDP ss1.atlanta.com:5060;branch=z9hG4bK2d4790.1  
;received=192.168.255.111  
From: BigGuy <sip:UserA@atlanta.com>;tag=9fxced76s1  
To: LittleGuy <sip:UserB@biloxi.com>  
Call-ID: 2xTb9vxSit55XU7p8@atlanta.com  
CSeq: 1 CANCEL  
Content-Length: 0

F13 CANCEL Proxy 2 -> B

Johnston, et al.

Informational

[Page 71]

CANCEL sip:UserB@192.168.200.201 SIP/2.0  
Via: SIP/2.0/UDP ss2.biloxi.com:5060;branch=z9hG4bK721e418c4.1  
Max-Forwards: 70  
From: BigGuy <sip:UserA@atlanta.com>;tag=9fxced76sl  
To: LittleGuy <sip:UserB@biloxi.com>  
Call-ID: 2xTb9vxSit55XU7p8@atlanta.com  
CSeq: 1 CANCEL  
Content-Length: 0

F14 200 OK B -> Proxy 2

SIP/2.0 200 OK  
Via: SIP/2.0/UDP ss2.biloxi.com:5060;branch=z9hG4bK721e418c4.1  
;received=192.168.156.222  
From: BigGuy <sip:UserA@atlanta.com>;tag=9fxced76sl  
To: LittleGuy <sip:UserB@biloxi.com>  
Call-ID: 2xTb9vxSit55XU7p8@atlanta.com  
CSeq: 1 CANCEL  
Content-Length: 0

F15 487 Request Terminated B -> Proxy 2

SIP/2.0 487 Request Terminated  
Via: SIP/2.0/UDP ss2.biloxi.com:5060;branch=z9hG4bK721e418c4.1  
;received=192.168.156.222  
Via: SIP/2.0/UDP ss1.atlanta.com:5060;branch=z9hG4bK2d4790.1  
;received=192.168.255.111  
Via: SIP/2.0/UDP client.atlanta.com:5060;branch=z9hG4bK74bf9  
;received=192.168.100.101  
From: BigGuy <sip:UserA@atlanta.com>;tag=9fxced76sl  
To: LittleGuy <sip:UserB@biloxi.com>;tag=314159  
Call-ID: 2xTb9vxSit55XU7p8@atlanta.com  
CSeq: 1 INVITE  
Content-Length: 0

F16 ACK Proxy 2 -> B

ACK sip:UserB@192.168.200.201 SIP/2.0  
Via: SIP/2.0/UDP ss2.biloxi.com:5060;branch=z9hG4bK721e418c4.1  
Max-Forwards: 70  
From: BigGuy <sip:UserA@atlanta.com>;tag=9fxced76sl  
To: LittleGuy <sip:UserB@biloxi.com>;tag=314159  
Call-ID: 2xTb9vxSit55XU7p8@atlanta.com  
CSeq: 1 ACK  
Content-Length: 0

F17 487 Request Terminated Proxy 2 -> Proxy 1

Johnston, et al.

Informational

[Page 72]



SIP/2.0 487 Request Terminated

Via: SIP/2.0/UDP ss1.atlanta.com:5060;branch=z9hG4bK2d4790.1  
;received=192.168.255.111

Via: SIP/2.0/UDP client.atlanta.com:5060;branch=z9hG4bK74bf9  
;received=192.168.100.101

From: BigGuy <sip:UserA@atlanta.com>;tag=9fxced76sl

To: LittleGuy <sip:UserB@biloxi.com>;tag=314159

Call-ID: 2xTb9vxSit55XU7p8@atlanta.com

CSeq: 1 INVITE

Content-Length: 0

F18 ACK Proxy 1 -> Proxy 2

ACK sip:UserB@biloxi.com SIP/2.0

Via: SIP/2.0/UDP ss2.biloxi.com:5060;branch=z9hG4bK721e418c4.1

Max-Forwards: 70

From: BigGuy <sip:UserA@atlanta.com>;tag=9fxced76sl

To: LittleGuy <sip:UserB@biloxi.com>;tag=314159

Call-ID: 2xTb9vxSit55XU7p8@atlanta.com

CSeq: 1 ACK

Content-Length: 0

F19 487 Request Terminated Proxy 1 -> A

SIP/2.0 487 Request Terminated

Via: SIP/2.0/UDP client.atlanta.com:5060;branch=z9hG4bK74bf9  
;received=192.168.100.101

From: BigGuy <sip:UserA@atlanta.com>;tag=9fxced76sl

To: LittleGuy <sip:UserB@biloxi.com>;tag=314159

Call-ID: 2xTb9vxSit55XU7p8@atlanta.com

CSeq: 1 INVITE

F20 ACK A -> Proxy 1

ACK sip:UserB@biloxi.com SIP/2.0

Via: SIP/2.0/UDP client.atlanta.com:5060;branch=z9hG4bK74bf9

Max-Forwards: 70

From: BigGuy <sip:UserA@atlanta.com>;tag=9fxced76sl

To: LittleGuy <sip:UserB@biloxi.com>;tag=314159

Call-ID: 2xTb9vxSit55XU7p8@atlanta.com

CSeq: 1 ACK

Content-Length: 0



**3.2.2 Unsuccessful SIP to SIP busy**

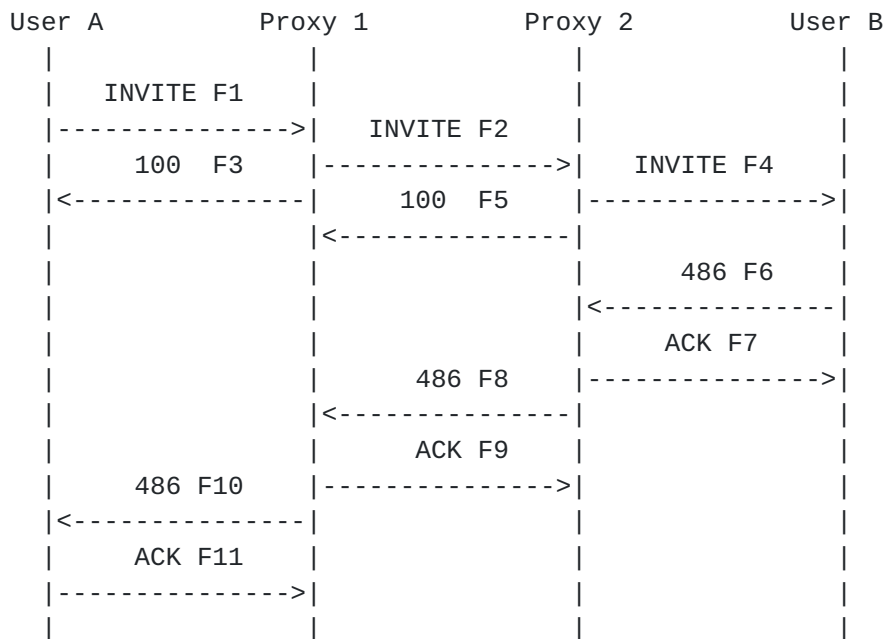

In this scenario, User B is busy and sends a 486 Busy Here response to User A's INVITE. Note that the non-2xx response is acknowledged on a hop-by-hop basis instead of end-to-end.

Message Details

F1 INVITE User A -> Proxy 1

```

INVITE sip:UserB@biloxi.com SIP/2.0
Via: SIP/2.0/UDP client.atlanta.com:5060;branch=z9hg4bk74bf9
Max-Forwards: 70
Route: <sip:ss1.atlanta.com;lr>
From: BigGuy <sip:UserA@atlanta.com>;tag=9fxced76s1
To: LittleGuy <sip:UserB@biloxi.com>
Call-ID: 2xTb9vxSit55XU7p8@atlanta.com
CSeq: 1 INVITE
Contact: <sip:UserA@192.168.100.101>
Proxy-Authorization: Digest username="UserA", realm="atlanta.com",
  nonce="dc3a5ab2530aa93112cf5904ba7d88fa", opaque="",
  uri="sip:UserB@biloxi.com",
  response="702138b27d869ac8741e10ec643d55be"
Content-Type: application/sdp
Content-Length: 147

v=0
o=UserA 2890844526 2890844526 IN IP4 client.atlanta.com
    
```

S=-  
c=IN IP4 192.168.100.101  
t=0 0

Johnston, et al.

Informational

[Page 74]

```
m=audio 49172 RTP/AVP 0
a=rtpmap:0 PCMU/8000
```

```
/*Client for A prepares to receive data on port 49172 from the
network.*/
```

```
F2 INVITE Proxy 1 -> Proxy 2
```

```
INVITE sip:UserB@biloxi.com SIP/2.0
Via: SIP/2.0/UDP ss1.atlanta.com:5060;branch=z9hG4bK2d4790.1
Via: SIP/2.0/UDP client.atlanta.com:5060;branch=z9hG4bK74bf9
;received=192.168.100.101
Max-Forwards: 69
Record-Route: <sip:ss1.atlanta.com;lr>
From: BigGuy <sip:UserA@atlanta.com>;tag=9fxced76s1
To: LittleGuy <sip:UserB@biloxi.com>
Call-ID: 2xTb9vxSit55XU7p8@atlanta.com
CSeq: 1 INVITE
Contact: <sip:UserA@192.168.100.101>
Content-Type: application/sdp
Content-Length: 147
```

```
v=0
o=UserA 2890844526 2890844526 IN IP4 client.atlanta.com
s=-
c=IN IP4 192.168.100.101
t=0 0
m=audio 49172 RTP/AVP 0
a=rtpmap:0 PCMU/8000
```

```
F3 100 Trying Proxy 1 -> User A
```

```
SIP/2.0 100 Trying
Via: SIP/2.0/UDP client.atlanta.com:5060;branch=z9hG4bK74bf9
;received=192.168.100.101
From: BigGuy <sip:UserA@atlanta.com>;tag=9fxced76s1
To: LittleGuy <sip:UserB@biloxi.com>
Call-ID: 2xTb9vxSit55XU7p8@atlanta.com
CSeq: 1 INVITE
Content-Length: 0
```

```
F4 INVITE Proxy 2 -> User B
```

```
INVITE sip:UserB@192.168.200.201 SIP/2.0
Via: SIP/2.0/UDP ss2.biloxi.com:5060;branch=z9hG4bK721e418c4.1
Via: SIP/2.0/UDP ss1.atlanta.com:5060;branch=z9hG4bK2d4790.1
;received=192.168.255.111
```

Via: SIP/2.0/UDP client.atlanta.com:5060;branch=z9hG4bK74bf9  
;received=192.168.100.101

Johnston, et al.

Informational

[Page 75]

Max-Forwards: 68  
Record-Route: <sip:ss2.biloxi.com;lr>, <sip:ss1.atlanta.com;lr>  
From: BigGuy <sip:UserA@atlanta.com>;tag=9fxced76s1  
To: LittleGuy <sip:UserB@biloxi.com>  
Call-ID: 2xTb9vxSit55XU7p8@atlanta.com  
CSeq: 1 INVITE  
Contact: <sip:UserA@192.168.100.101>  
Content-Type: application/sdp  
Content-Length: 147

v=0  
o=UserA 2890844526 2890844526 IN IP4 client.atlanta.com  
s=-  
c=IN IP4 192.168.100.101  
t=0 0  
m=audio 49172 RTP/AVP 0  
a=rtpmap:0 PCMU/8000

F5 100 Trying Proxy 2 -> Proxy 1

SIP/2.0 100 Trying  
Via: SIP/2.0/UDP ss1.atlanta.com:5060;branch=z9hG4bK2d4790.1  
;received=192.168.255.111  
Via: SIP/2.0/UDP client.atlanta.com:5060;branch=z9hG4bK74bf9  
;received=192.168.100.101  
From: BigGuy <sip:UserA@atlanta.com>;tag=9fxced76s1  
To: LittleGuy <sip:UserB@biloxi.com>  
Call-ID: 2xTb9vxSit55XU7p8@atlanta.com  
CSeq: 1 INVITE  
Content-Length: 0

F6 486 Busy Here User B -> Proxy 2

SIP/2.0 486 Busy Here  
Via: SIP/2.0/UDP ss2.biloxi.com:5060;branch=z9hG4bK721e418c4.1  
;received=192.168.156.222  
Via: SIP/2.0/UDP ss1.atlanta.com:5060;branch=z9hG4bK2d4790.1  
;received=192.168.255.111  
Via: SIP/2.0/UDP client.atlanta.com:5060;branch=z9hG4bK74bf9  
;received=192.168.100.101  
From: BigGuy <sip:UserA@atlanta.com>;tag=9fxced76s1  
To: LittleGuy <sip:UserB@biloxi.com>;tag=314159  
Call-ID: 2xTb9vxSit55XU7p8@atlanta.com  
CSeq: 1 INVITE  
Content-Length: 0

F7 ACK Proxy 2 -> User B

ACK sip:UserB@192.168.200.201 SIP/2.0

Johnston, et al.

Informational

[Page 76]



Via: SIP/2.0/UDP ss2.biloxi.com:5060;branch=z9hG4bK721e418c4.1  
Max-Forwards: 70  
From: BigGuy <sip:UserA@atlanta.com>;tag=9fxced76s1  
To: LittleGuy <sip:UserB@biloxi.com>;tag=314159  
Call-ID: 2xTb9vxSit55XU7p8@atlanta.com  
CSeq: 1 ACK  
Content-Length: 0

F8 486 Busy Here Proxy 2 -> Proxy 1

SIP/2.0 486 Busy Here  
Via: SIP/2.0/UDP ss1.atlanta.com:5060;branch=z9hG4bK2d4790.1  
;received=192.168.255.111  
Via: SIP/2.0/UDP client.atlanta.com:5060;branch=z9hG4bK74bf9  
;received=192.168.100.101  
From: BigGuy <sip:UserA@atlanta.com>;tag=9fxced76s1  
To: LittleGuy <sip:UserB@biloxi.com>;tag=314159  
Call-ID: 2xTb9vxSit55XU7p8@atlanta.com  
CSeq: 1 INVITE  
Content-Length: 0

F9 ACK Proxy 1 -> Proxy 2

ACK sip:UserB@biloxi.com SIP/2.0  
Via: SIP/2.0/UDP ss1.atlanta.com:5060;branch=z9hG4bK2d4790.1  
Max-Forwards: 70  
From: BigGuy <sip:UserA@atlanta.com>;tag=9fxced76s1  
To: LittleGuy <sip:UserB@biloxi.com>;tag=314159  
Call-ID: 2xTb9vxSit55XU7p8@atlanta.com  
CSeq: 1 ACK  
Content-Length: 0

F10 486 Busy Here Proxy 1 -> User A

SIP/2.0 486 Busy Here  
Via: SIP/2.0/UDP client.atlanta.com:5060;branch=z9hG4bK74bf9  
;received=192.168.100.101  
From: BigGuy <sip:UserA@atlanta.com>;tag=9fxced76s1  
To: LittleGuy <sip:UserB@biloxi.com>;tag=314159  
Call-ID: 2xTb9vxSit55XU7p8@atlanta.com  
CSeq: 1 INVITE  
Content-Length: 0

F11 ACK User A -> Proxy 1

ACK sip:UserB@biloxi.com SIP/2.0

Via: SIP/2.0/UDP client.atlanta.com:5060;branch=z9hG4bK74bf9  
Max-Forwards: 70

Johnston, et al.

Informational

[Page 77]

From: BigGuy <sip:UserA@atlanta.com>;tag=9fxced76sl  
To: LittleGuy <sip:UserB@biloxi.com>;tag=314159  
Call-ID: 2xTb9vxSit55XU7p8@atlanta.com  
CSeq: 1 ACK  
Content-Length: 0



**3.2.3 Unsuccessful SIP to SIP no response**

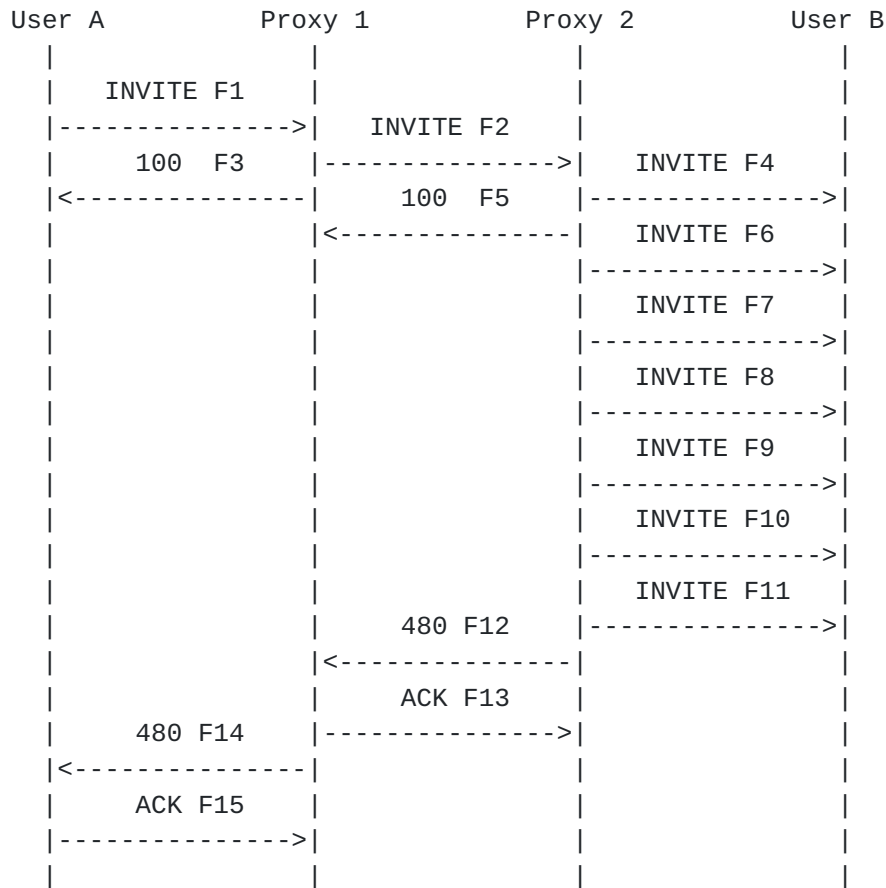

In this example, there is no response from User B to User A's INVITE messages being re-transmitted by Proxy 2. After the sixth re-transmission, Proxy 2 gives up and sends a 480 No Response to User A.

Message Details

F1 INVITE User A -> Proxy 1

```

INVITE sip:UserB@biloxi.com SIP/2.0
Via: SIP/2.0/UDP client.atlanta.com:5060;branch=z9hG4bK74bf9
Max-Forwards: 70
Route: <sip:ss1.atlanta.com;lr>
From: BigGuy <sip:UserA@atlanta.com>;tag=9fxced76s1
To: LittleGuy <sip:UserB@biloxi.com>
Call-ID: 2xTb9vxSit55XU7p8@atlanta.com
CSeq: 1 INVITE
Contact: <sip:UserA@192.168.100.101>
Proxy-Authorization: Digest username="UserA", realm="atlanta.com",
  nonce="cf5904ba7d8dc3a5ab2530aa931128fa", opaque="",
    
```

uri="sip:UserB@biloxi.com",  
response="7afc04be7961f053c24f80e7dbaf888f"  
Content-Type: application/sdp

Johnston, et al.

Informational

[Page 79]

Content-Length: 147

```
v=0
o=UserA 2890844526 2890844526 IN IP4 client.atlanta.com
s=-
c=IN IP4 192.168.100.101
t=0 0
m=audio 49172 RTP/AVP 0
a=rtpmap:0 PCMU/8000
```

/\*Client for A prepares to receive data on port 49172 from the network.\*/

F2 INVITE Proxy 1 -> Proxy 2

```
INVITE sip:UserB@biloxi.com SIP/2.0
Via: SIP/2.0/UDP ss1.atlanta.com:5060;branch=z9hG4bK2d4790.1
Via: SIP/2.0/UDP client.atlanta.com:5060;branch=z9hG4bK74bf9
;received=192.168.100.101
Max-Forwards: 69
Record-Route: <sip:ss1.atlanta.com;lr>
From: BigGuy <sip:UserA@atlanta.com>;tag=9fxced76s1
To: LittleGuy <sip:UserB@biloxi.com>
Call-ID: 2xTb9vxSit55XU7p8@atlanta.com
CSeq: 1 INVITE
Contact: <sip:UserA@192.168.100.101>
Content-Type: application/sdp
Content-Length: 147
```

```
v=0
o=UserA 2890844526 2890844526 IN IP4 client.atlanta.com
s=-
c=IN IP4 192.168.100.101
t=0 0
m=audio 49172 RTP/AVP 0
a=rtpmap:0 PCMU/8000
```

F3 100 Trying Proxy 1 -> User A

```
SIP/2.0 100 Trying
Via: SIP/2.0/UDP client.atlanta.com:5060;branch=z9hG4bK74bf9
;received=192.168.100.101
From: BigGuy <sip:UserA@atlanta.com>;tag=9fxced76s1
To: LittleGuy <sip:UserB@biloxi.com>
Call-ID: 2xTb9vxSit55XU7p8@atlanta.com
CSeq: 1 INVITE
Content-Length: 0
```

F4 INVITE Proxy 2 -> User B

Johnston, et al.

Informational

[Page 80]



```
INVITE sip:UserB@192.168.200.201 SIP/2.0
Via: SIP/2.0/UDP ss2.biloxi.com:5060;branch=z9hG4bK721e418c4.1
Via: SIP/2.0/UDP ss1.atlanta.com:5060;branch=z9hG4bK2d4790.1
    ;received=192.168.255.111
Via: SIP/2.0/UDP client.atlanta.com:5060;branch=z9hG4bK74bf9
    ;received=192.168.100.101
Max-Forwards: 68
Record-Route: <sip:ss2.biloxi.com;lr>, <sip:ss1.atlanta.com;lr>
From: BigGuy <sip:UserA@atlanta.com>;tag=9fxced76sl
To: LittleGuy <sip:UserB@biloxi.com>
Call-ID: 2xTb9vxSit55XU7p8@atlanta.com
CSeq: 1 INVITE
Contact: <sip:UserA@192.168.100.101>
Content-Type: application/sdp
Content-Length: 147
```

```
v=0
o=UserA 2890844526 2890844526 IN IP4 client.atlanta.com
s=-
c=IN IP4 192.168.100.101
t=0 0
m=audio 49172 RTP/AVP 0
a=rtpmap:0 PCMU/8000
```

F5 100 Trying Proxy 2 -> Proxy 1

```
SIP/2.0 100 Trying
Via: SIP/2.0/UDP ss1.atlanta.com:5060;branch=z9hG4bK2d4790.1
    ;received=192.168.255.111
Via: SIP/2.0/UDP client.atlanta.com:5060;branch=z9hG4bK74bf9
    ;received=192.168.100.101
From: BigGuy <sip:UserA@atlanta.com>;tag=9fxced76sl
To: LittleGuy <sip:UserB@biloxi.com>
Call-ID: 2xTb9vxSit55XU7p8@atlanta.com
CSeq: 1 INVITE
Content-Length: 0
```

F6 INVITE Proxy 2 -> User B

Resend of Message F4

F7 INVITE Proxy 2 -> User B

Resend of Message F4

F8 INVITE Proxy 2 -> User B

Johnston, et al.

Informational

[Page 81]

Resend of Message F4

F9 INVITE Proxy 2 -> User B

Resend of Message F4

F10 INVITE Proxy 2 -> User B

Resend of Message F4

F11 INVITE Proxy 2 -> User B

Resend of Message F4

/\* Proxy 2 gives up \*/

F12 480 No Response Proxy 2 -> Proxy 1

SIP/2.0 480 No Response

Via: SIP/2.0/UDP ss1.atlanta.com:5060;branch=z9hG4bK2d4790.1  
;received=192.168.255.111

Via: SIP/2.0/UDP client.atlanta.com:5060;branch=z9hG4bK74bf9  
;received=192.168.100.101

From: BigGuy <sip:UserA@atlanta.com>;tag=9fxced76s1

To: LittleGuy <sip:UserB@biloxi.com>;tag=314159

Call-ID: 2xTb9vxSit55XU7p8@atlanta.com

CSeq: 1 INVITE

Content-Length: 0

F13 ACK Proxy 1 -> Proxy 2

ACK sip:UserB@biloxi.com SIP/2.0

Via: SIP/2.0/UDP ss1.atlanta.com:5060;branch=z9hG4bK2d4790.1  
Max-Forwards: 70

From: BigGuy <sip:UserA@atlanta.com>;tag=9fxced76s1

To: LittleGuy <sip:UserB@biloxi.com>;tag=314159

Call-ID: 2xTb9vxSit55XU7p8@atlanta.com

CSeq: 1 ACK

Content-Length: 0

F14 480 No Response Proxy 1 -> User A

SIP/2.0 480 No Response

Via: SIP/2.0/UDP client.atlanta.com:5060;branch=z9hG4bK74bf9

;received=192.168.100.101

From: BigGuy <sip:UserA@atlanta.com>;tag=9fxced76sl

Johnston, et al.

Informational

[Page 82]

To: LittleGuy <sip:UserB@biloxi.com>;tag=314159  
Call-ID: 2xTb9vxSit55XU7p8@atlanta.com  
CSeq: 1 INVITE  
Content-Length: 0

F15 ACK User A -> Proxy 1

ACK sip:UserB@biloxi.com SIP/2.0  
Via: SIP/2.0/UDP client.atlanta.com:5060;branch=z9hG4bK74bf9  
Max-Forwards: 70  
From: BigGuy <sip:UserA@atlanta.com>;tag=9fxced76sl  
To: LittleGuy <sip:UserB@biloxi.com>;tag=314159  
Call-ID: 2xTb9vxSit55XU7p8@atlanta.com  
CSeq: 1 ACK  
Content-Length: 0



**3.2.4 Unsuccessful SIP to SIP Temporarily Unavailable**

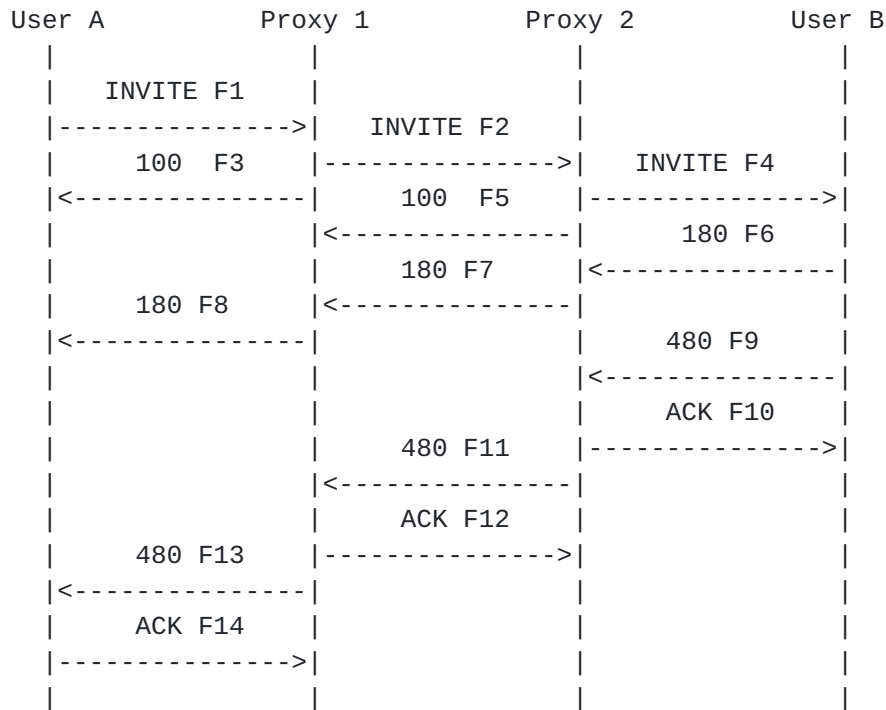

In this scenario, User B initially sends a 180 Ringing response to User A, indicating that alerting is taking place. However, then a 480 Unavailable is then sent to User A. This response is acknowledged then proxied back to User A.

Message Details

F1 INVITE A -> Proxy 1

```

INVITE sip:UserB@biloxi.com SIP/2.0
Via: SIP/2.0/UDP client.atlanta.com:5060;branch=z9hG4bK74bf9
Max-Forwards: 70
Route: <sip:ss1.atlanta.com;lr>
From: BigGuy <sip:UserA@atlanta.com>;tag=9fxced76s1
To: LittleGuy <sip:UserB@biloxi.com>
Call-ID: 2xTb9vxSit55XU7p8@atlanta.com
CSeq: 1 INVITE
Contact: <sip:UserA@192.168.100.101>
Proxy-Authorization: Digest username="UserA", realm="atlanta.com",
  nonce="aa9311cf5904ba7d8dc3a5ab253028fa", opaque="",
  uri="sip:UserB@biloxi.com",
  response="59a46a91bf1646562a4d486c84b399db"
Content-Type: application/sdp
    
```

Content-Length: 147

v=0

Johnston, et al.

Informational

[Page 84]



```
o=UserA 2890844526 2890844526 IN IP4 client.atlanta.com
s=-
c=IN IP4 192.168.100.101
t=0 0
m=audio 49172 RTP/AVP 0
a=rtpmap:0 PCMU/8000
```

```
/*Client for A prepares to receive data on port 49172 from the
network.*/
```

```
F2 INVITE Proxy 1 -> Proxy 2
```

```
INVITE sip:UserB@biloxi.com SIP/2.0
Via: SIP/2.0/UDP ss1.atlanta.com:5060;branch=z9hG4bK2d4790.1
Via: SIP/2.0/UDP client.atlanta.com:5060;branch=z9hG4bK74bf9
;received=192.168.100.101
Max-Forwards: 69
Record-Route: <sip:ss1.atlanta.com;lr>
From: BigGuy <sip:UserA@atlanta.com>;tag=9fxced76sl
To: LittleGuy <sip:UserB@biloxi.com>
Call-ID: 2xTb9vxSit55XU7p8@atlanta.com
CSeq: 1 INVITE
Contact: <sip:UserA@192.168.100.101>
Content-Type: application/sdp
Content-Length: 147
```

```
v=0
o=UserA 2890844526 2890844526 IN IP4 client.atlanta.com
s=-
c=IN IP4 192.168.100.101
t=0 0
m=audio 49172 RTP/AVP 0
a=rtpmap:0 PCMU/8000
```

```
F3 100 Trying Proxy 1 -> A
```

```
SIP/2.0 100 Trying
Via: SIP/2.0/UDP client.atlanta.com:5060;branch=z9hG4bK74bf9
;received=192.168.100.101
From: BigGuy <sip:UserA@atlanta.com>;tag=9fxced76sl
To: LittleGuy <sip:UserB@biloxi.com>
Call-ID: 2xTb9vxSit55XU7p8@atlanta.com
CSeq: 1 INVITE
Content-Length: 0
```

```
F4 INVITE Proxy 2 -> B
```

INVITE sip:UserB@192.168.200.201 SIP/2.0

Via: SIP/2.0/UDP ss2.biloxi.com:5060;branch=z9hG4bK721e418c4.1

Johnston, et al.

Informational

[Page 85]

Via: SIP/2.0/UDP ss1.atlanta.com:5060;branch=z9hG4bK2d4790.1  
;received=192.168.255.111  
Via: SIP/2.0/UDP client.atlanta.com:5060;branch=z9hG4bK74bf9  
;received=192.168.100.101  
Max-Forwards: 68  
Record-Route: <sip:ss2.biloxi.com;lr>, <sip:ss1.atlanta.com;lr>  
From: BigGuy <sip:UserA@atlanta.com>;tag=9fxced76sl  
To: LittleGuy <sip:UserB@biloxi.com>  
Call-ID: 2xTb9vxSit55XU7p8@atlanta.com  
CSeq: 1 INVITE  
Contact: <sip:UserA@192.168.100.101>  
Content-Type: application/sdp  
Content-Length: 147

v=0  
o=UserA 2890844526 2890844526 IN IP4 client.atlanta.com  
s=-  
c=IN IP4 192.168.100.101  
t=0 0  
m=audio 49172 RTP/AVP 0  
a=rtpmap:0 PCMU/8000

F5 100 Trying Proxy 2 -> Proxy 1

SIP/2.0 100 Trying  
Via: SIP/2.0/UDP ss1.atlanta.com:5060;branch=z9hG4bK2d4790.1  
;received=192.168.255.111  
Via: SIP/2.0/UDP client.atlanta.com:5060;branch=z9hG4bK74bf9  
;received=192.168.100.101  
From: BigGuy <sip:UserA@atlanta.com>;tag=9fxced76sl  
To: LittleGuy <sip:UserB@biloxi.com>  
Call-ID: 2xTb9vxSit55XU7p8@atlanta.com  
CSeq: 1 INVITE  
Content-Length: 0

F6 180 Ringing B -> Proxy 2

SIP/2.0 180 Ringing  
Via: SIP/2.0/UDP ss2.biloxi.com:5060;branch=z9hG4bK721e418c4.1  
;received=192.168.156.222  
Via: SIP/2.0/UDP ss1.atlanta.com:5060;branch=z9hG4bK2d4790.1  
;received=192.168.255.111  
Via: SIP/2.0/UDP client.atlanta.com:5060;branch=z9hG4bK74bf9  
;received=192.168.100.101  
Record-Route: <sip:ss2.biloxi.com;lr>, <sip:ss1.atlanta.com;lr>  
From: BigGuy <sip:UserA@atlanta.com>;tag=9fxced76sl  
To: LittleGuy <sip:UserB@biloxi.com>;tag=314159

Call-ID: 2xTb9vxSit55XU7p8@atlanta.com  
CSeq: 1 INVITE  
Contact: <sip:UserB@192.168.200.201>

Johnston, et al.

Informational

[Page 86]

Content-Length: 0

F7 180 Ringing Proxy 2 -> Proxy 1

SIP/2.0 180 Ringing

Via: SIP/2.0/UDP ss1.atlanta.com:5060;branch=z9hG4bK2d4790.1  
;received=192.168.255.111

Via: SIP/2.0/UDP client.atlanta.com:5060;branch=z9hG4bK74bf9  
;received=192.168.100.101

Record-Route: <sip:ss2.biloxi.com;lr>, <sip:ss1.atlanta.com;lr>

From: BigGuy <sip:UserA@atlanta.com>;tag=9fxced76sl

To: LittleGuy <sip:UserB@biloxi.com>;tag=314159

Call-ID: 2xTb9vxSit55XU7p8@atlanta.com

CSeq: 1 INVITE

Contact: <sip:UserB@192.168.200.201>

Content-Length: 0

F8 180 Ringing Proxy 1 -> A

SIP/2.0 180 Ringing

Via: SIP/2.0/UDP client.atlanta.com:5060;branch=z9hG4bK74bf9  
;received=192.168.100.101

Record-Route: <sip:ss2.biloxi.com;lr>, <sip:ss1.atlanta.com;lr>

From: BigGuy <sip:UserA@atlanta.com>;tag=9fxced76sl

To: LittleGuy <sip:UserB@biloxi.com>;tag=314159

Call-ID: 2xTb9vxSit55XU7p8@atlanta.com

CSeq: 1 INVITE

Contact: <sip:UserB@192.168.200.201>

Content-Length: 0

F9 480 Temporarily Unavailable B -> Proxy 2

SIP/2.0 480 Temporarily Unavailable

Via: SIP/2.0/UDP ss2.biloxi.com:5060;branch=z9hG4bK721e418c4.1  
;received=192.168.156.222

Via: SIP/2.0/UDP ss1.atlanta.com:5060;branch=z9hG4bK2d4790.1  
;received=192.168.255.111

Via: SIP/2.0/UDP client.atlanta.com:5060;branch=z9hG4bK74bf9  
;received=192.168.100.101

From: BigGuy <sip:UserA@atlanta.com>;tag=9fxced76sl

To: LittleGuy <sip:UserB@biloxi.com>;tag=314159

Call-ID: 2xTb9vxSit55XU7p8@atlanta.com

CSeq: 1 INVITE

Content-Length: 0

F10 ACK Proxy 2 -> B

ACK sip:UserB@192.168.200.201 SIP/2.0

Johnston, et al.

Informational

[Page 87]

Via: SIP/2.0/UDP ss2.biloxi.com:5060;branch=z9hG4bK721e418c4.1  
Max-Forwards: 70  
From: BigGuy <sip:UserA@atlanta.com>;tag=9fxced76s1  
To: LittleGuy <sip:UserB@biloxi.com>;tag=314159  
Call-ID: 2xTb9vxSit55XU7p8@atlanta.com  
CSeq: 1 ACK  
Content-Length: 0

F11 480 Temporarily Unavailable Proxy 2 -> Proxy 1

SIP/2.0 480 Temporarily Unavailable  
Via: SIP/2.0/UDP ss1.atlanta.com:5060;branch=z9hG4bK2d4790.1  
;received=192.168.255.111  
Via: SIP/2.0/UDP client.atlanta.com:5060;branch=z9hG4bK74bf9  
;received=192.168.100.101  
From: BigGuy <sip:UserA@atlanta.com>;tag=9fxced76s1  
To: LittleGuy <sip:UserB@biloxi.com>;tag=314159  
Call-ID: 2xTb9vxSit55XU7p8@atlanta.com  
CSeq: 1 INVITE  
Content-Length: 0

F12 ACK Proxy 1 -> Proxy 2

ACK sip:UserB@biloxi.com SIP/2.0  
Via: SIP/2.0/UDP ss1.atlanta.com:5060;branch=z9hG4bK2d4790.1  
Max-Forwards: 70  
From: BigGuy <sip:UserA@atlanta.com>;tag=9fxced76s1  
To: LittleGuy <sip:UserB@biloxi.com>;tag=314159  
Call-ID: 2xTb9vxSit55XU7p8@atlanta.com  
CSeq: 1 ACK  
Content-Length: 0

F13 480 Temporarily Unavailable Proxy 1 -> A

SIP/2.0 480 Temporarily Unavailable  
Via: SIP/2.0/UDP client.atlanta.com:5060;branch=z9hG4bK74bf9  
;received=192.168.100.101  
From: BigGuy <sip:UserA@atlanta.com>;tag=9fxced76s1  
To: LittleGuy <sip:UserB@biloxi.com>;tag=314159  
Call-ID: 2xTb9vxSit55XU7p8@atlanta.com  
CSeq: 1 INVITE  
Content-Length: 0

F14 ACK A -> Proxy 1

ACK sip:UserB@biloxi.com SIP/2.0

Via: SIP/2.0/UDP client.atlanta.com:5060;branch=z9hG4bK74bf9  
Max-Forwards: 70

Johnston, et al.

Informational

[Page 88]



From: BigGuy <sip:UserA@atlanta.com>;tag=9fxced76sl  
To: LittleGuy <sip:UserB@biloxi.com>;tag=314159  
Call-ID: 2xTb9vxSit55XU7p8@atlanta.com  
CSeq: 1 ACK  
Content-Length: 0



## **4 SIP to Gateway Dialing**

In the following scenarios, User A (BigGuy sip:UserA@atlanta.com) is a SIP phone or other SIP-enabled device. User B is reachable via the PSTN at global telephone number +19725552222. User A places a call to User B through a Proxy Server Proxy 1 and a Network Gateway. In other scenarios, User A places calls to User C, who is served via a PBX (Private Branch Exchange) and is identified by a private extension 444-3333, or global number +1-918-555-3333. Note that User A uses his/her global telephone number +1-314-555-1111 in the From header in the INVITE messages. This then gives the Gateway the option of using this header to populate the calling party identification field in subsequent signaling (CgPN in ISUP). Left open is the issue of how the Gateway can determine the accuracy of the telephone number, necessary before passing it as a valid CgPN in the PSTN.

There is a major difference in the call flows in this section. In-band alerting (ringing tone, busy tone, recorded announcements, etc.) may be present in the PSTN speech path after the receipt of the SS7 Address Complete Message (ACM) which maps to the SIP 180 Ringing response. To establish a two way media path prior to the call being answered (200 OK), a 183 Session Progress response is sent instead of a 180 Ringing. Note that since this 183 response is not sent reliably, it should be periodically resent by the gateway. The same SDP in the 183 should also be present in the 200 OK when the call is answered.

### **4.1 Success Scenarios**

In these scenarios, User A is a SIP phone or other SIP-enabled device. User A places a call to User B in the PSTN or User C on a PBX through a Proxy Server and a Gateway.



**4.1.1 Successful SIP to ISUP PSTN call**

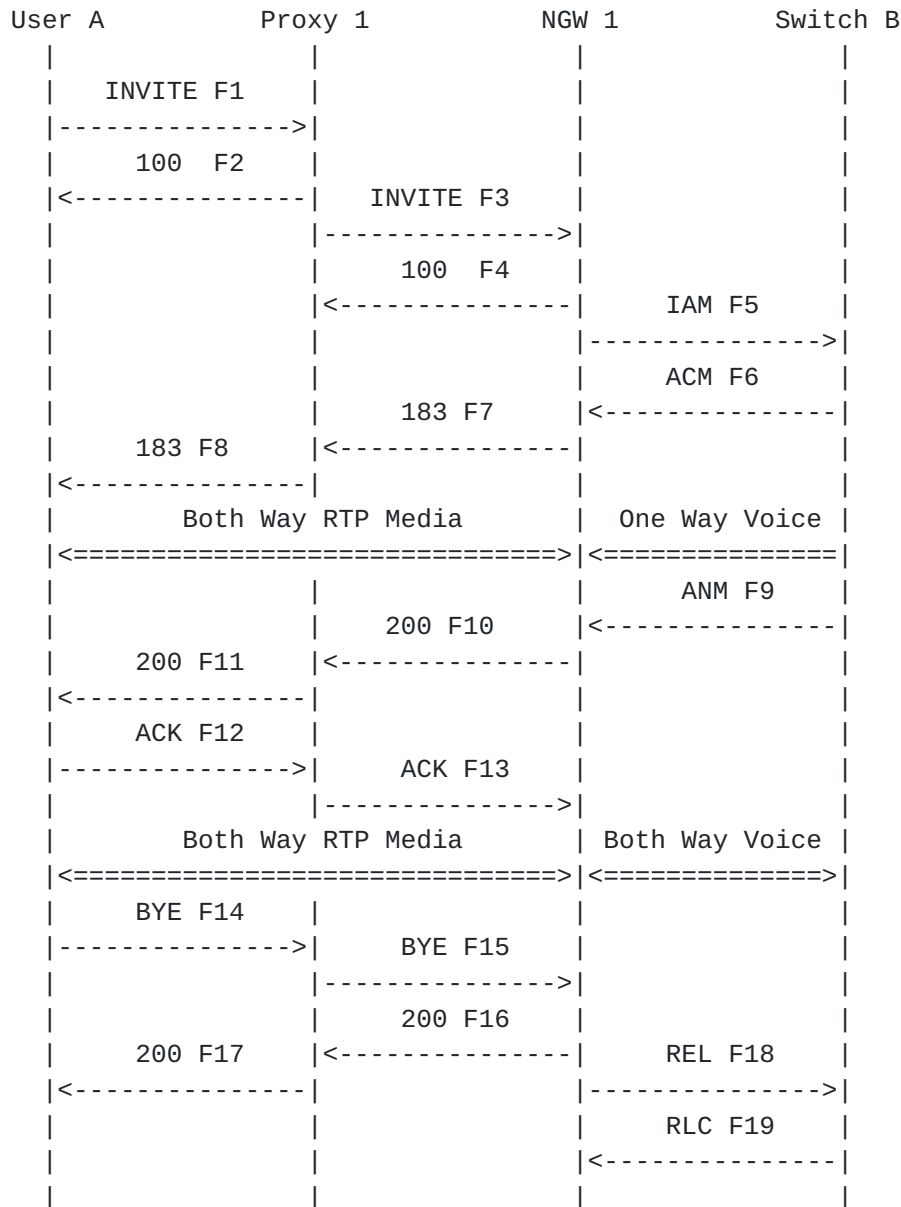

User A dials the globalized E.164 number +19725552222 to reach User B. Note that A might have only dialed the last 7 digits, or some other dialing plan. It is assumed that the SIP User Agent Client converts the digits into a global number and puts them into a SIP URI. Note that tel URIs could be used instead of SIP URIs.

User A could use either their SIP address (sip:UserA@atlanta.com) or SIP telephone number (sip:+13145551111@ss1.atlanta.com;user=phone) in the From header. In this example, the telephone number is included, and it is shown as being passed as calling party identification

through the Network Gateway (NGW 1) to User B (F5). Note that for this number to be passed into the SS7 network, it would have to be somehow verified for accuracy.

In this scenario, User B answers the call then User A disconnects the call. Signaling between NGW 1 and User B's telephone switch is ANSI ISUP. For the details of SIP to ISUP mapping, refer to [[SIP-ISUP](#)].

#### Message Details

F1 INVITE A -> Proxy 1

```
INVITE sip:+19725552222@ss1.atlanta.com;user=phone SIP/2.0
Via: SIP/2.0/UDP client.atlanta.com:5060;branch=z9hG4bK74bf9
Max-Forwards: 70
From: BigGuy <sip:+13145551111@ss1.atlanta.com;user=phone>
;tag=9fxced76sl
To: LittleGuy <sip:+19725552222@ss1.atlanta.com;user=phone>
Call-ID: 2xTb9vxSit55XU7p8@atlanta.com
CSeq: 1 INVITE
Contact: <sip:UserA@192.168.100.101>
Proxy-Authorization: Digest username="UserA", realm="atlanta.com",
  nonce="dc3a5ab25302aa931904ba7d88fa1cf5", opaque="",
  uri="sip:+19725552222@ss1.atlanta.com;user=phone",
  response="ccdca50cb091d587421457305d097458c"
Content-Type: application/sdp
Content-Length: 147
```

```
v=0
o=UserA 2890844526 2890844526 IN IP4 client.atlanta.com
s=-
c=IN IP4 192.168.100.101
t=0 0
m=audio 49172 RTP/AVP 0
a=rtpmap:0 PCMU/8000
```

F2 100 Trying Proxy 1 -> User A

```
SIP/2.0 100 Trying
Via: SIP/2.0/UDP client.atlanta.com:5060;branch=z9hG4bK74bf9
;received=192.168.100.101
From: BigGuy <sip:+13145551111@ss1.atlanta.com;user=phone>
;tag=9fxced76sl
To: LittleGuy <sip:+19725552222@ss1.atlanta.com;user=phone>
Call-ID: 2xTb9vxSit55XU7p8@atlanta.com
CSeq: 1 INVITE
Content-Length: 0
```

/\* Proxy 1 uses a Location Service function to determine the gateway

for terminating this call. The call is forwarded to NGW 1. Client  
for A prepares to receive data on port 49172 from the

Johnston, et al.

Informational

[Page 92]



network.\*/  
network.\*

F3 INVITE Proxy 1 -> NGW 1

```
INVITE sip:+19725552222@ngw1.atlanta.com;user=phone SIP/2.0
Via: SIP/2.0/UDP ss1.atlanta.com:5060;branch=z9hG4bK2d4790.1
Via: SIP/2.0/UDP client.atlanta.com:5060;branch=z9hG4bK74bf9
;received=192.168.100.101
Max-Forwards: 69
Record-Route: <sip:ss1.atlanta.com;lr>
From: BigGuy <sip:+13145551111@ss1.atlanta.com;user=phone>
;tag=9fxced76s1
To: LittleGuy <sip:+19725552222@ss1.atlanta.com;user=phone>
Call-ID: 2xTb9vxSit55XU7p8@atlanta.com
CSeq: 1 INVITE
Contact: <sip:UserA@192.168.100.101>
Content-Type: application/sdp
Content-Length: 147
```

```
v=0
o=UserA 2890844526 2890844526 IN IP4 client.atlanta.com
s=-
c=IN IP4 192.168.100.101
t=0 0
m=audio 49172 RTP/AVP 0
a=rtpmap:0 PCMU/8000
```

F4 100 Trying NGW 1 -> Proxy 1

```
SIP/2.0 100 Trying
Via: SIP/2.0/UDP ss1.atlanta.com:5060;branch=z9hG4bK2d4790.1
;received=192.168.255.111
From: BigGuy <sip:+13145551111@ss1.atlanta.com;user=phone>
;tag=9fxced76s1
To: LittleGuy <sip:+19725552222@ss1.atlanta.com;user=phone>
Call-ID: 2xTb9vxSit55XU7p8@atlanta.com
CSeq: 1 INVITE
Content-Length: 0
```

F5 IAM NGW 1 -> User B

```
IAM
CdPN=972-555-2222,NPI=E.164,NOA=National
CgPN=314-555-1111,NPI=E.164,NOA=National
```

F6 ACM User B -> NGW 1



F7 183 Session Progress NGW 1 -> Proxy 1

SIP/2.0 183 Session Progress

Via: SIP/2.0/UDP ss1.atlanta.com:5060;branch=z9hG4bK2d4790.1  
;received=192.168.255.111

Via: SIP/2.0/UDP client.atlanta.com:5060;branch=z9hG4bK74bf9  
;received=192.168.100.101

Record-Route: <sip:ss1.atlanta.com;lr>

From: BigGuy <sip:+13145551111@ss1.atlanta.com;user=phone>  
;tag=9fxced76s1

To: LittleGuy <sip:+19725552222@ss1.atlanta.com;user=phone>  
;tag=314159

Call-ID: 2xTb9vxSit55XU7p8@atlanta.com

CSeq: 1 INVITE

Contact: <sip:+19725552222@ngw1.atlanta.com;user=phone>

Content-Type: application/sdp

Content-Length: 141

v=0

o=GW 2890844527 2890844527 IN IP4 ngw1.atlanta.com

s=-

c=IN IP4 192.168.255.101

t=0 0

m=audio 3456 RTP/AVP 0

a=rtpmap:0 PCMU/8000

/\* NGW 1 sends PSTN audio (ringing) in the RTP path to A \*/

F8 183 Session Progress Proxy 1 -> User A

SIP/2.0 183 Session Progress

Via: SIP/2.0/UDP client.atlanta.com:5060;branch=z9hG4bK74bf9  
;received=192.168.100.101

Record-Route: <sip:ss1.atlanta.com;lr>

From: BigGuy <sip:+13145551111@ss1.atlanta.com;user=phone>  
;tag=9fxced76s1

To: LittleGuy <sip:+19725552222@ss1.atlanta.com;user=phone>  
;tag=314159

Call-ID: 2xTb9vxSit55XU7p8@atlanta.com

CSeq: 1 INVITE

Contact: <sip:+19725552222@ngw1.atlanta.com;user=phone>

Content-Type: application/sdp

Content-Length: 141

v=0

o=GW 2890844527 2890844527 IN IP4 ngw1.atlanta.com

s=-

c=IN IP4 192.168.255.101  
t=0 0  
m=audio 3456 RTP/AVP 0

Johnston, et al.

Informational

[Page 94]

a=rtpmap:0 PCMU/8000

F9 ANM User B -> NGW 1

ANM

F10 200 OK NGW 1 -> Proxy 1

SIP/2.0 200 OK

Via: SIP/2.0/UDP ss1.atlanta.com:5060;branch=z9hG4bK2d4790.1  
;received=192.168.255.111

Via: SIP/2.0/UDP client.atlanta.com:5060;branch=z9hG4bK74bf9  
;received=192.168.100.101

Record-Route: <sip:ss1.atlanta.com;lr>

From: BigGuy <sip:+13145551111@ss1.atlanta.com;user=phone>  
;tag=9fxced76sl

To: LittleGuy <sip:+19725552222@ss1.atlanta.com;user=phone>  
;tag=314159

Call-ID: 2xTb9vxSit55XU7p8@atlanta.com

CSeq: 1 INVITE

Contact: <sip:+19725552222@ngw1.atlanta.com;user=phone>

Content-Type: application/sdp

Content-Length: 141

v=0

o=GW 2890844527 2890844527 IN IP4 ngw1.atlanta.com

s=-

c=IN IP4 192.168.255.201

t=0 0

m=audio 3456 RTP/AVP 0

a=rtpmap:0 PCMU/8000

F11 200 OK Proxy 1 -> User A

SIP/2.0 200 OK

Via: SIP/2.0/UDP client.atlanta.com:5060;branch=z9hG4bK74bf9  
;received=192.168.100.101

Record-Route: <sip:ss1.atlanta.com;lr>

From: BigGuy <sip:+13145551111@ss1.atlanta.com;user=phone>  
;tag=9fxced76sl

To: LittleGuy <sip:+19725552222@ss1.atlanta.com;user=phone>  
;tag=314159

Call-ID: 2xTb9vxSit55XU7p8@atlanta.com

CSeq: 1 INVITE

Contact: <sip:+19725552222@ngw1.atlanta.com;user=phone>

Content-Type: application/sdp

Content-Length: 141

v=0

Johnston, et al.

Informational

[Page 95]

```
o=GW 2890844527 2890844527 IN IP4 ngw1.atlanta.com
s=-
c=IN IP4 192.168.255.101
t=0 0
m=audio 3456 RTP/AVP 0
a=rtpmap:0 PCMU/8000
```

F12 ACK A -> Proxy 1

```
ACK sip:+19725552222@ngw1.atlanta.com;user=phone SIP/2.0
Via: SIP/2.0/UDP client.atlanta.com:5060;branch=z9hG4bK74bf9
Max-Forwards: 70
Route: <sip:ss1.atlanta.com;lr>
From: BigGuy <sip:+13145551111@ss1.atlanta.com;user=phone>
;tag=9fxced76sl
To: LittleGuy <sip:+19725552222@ss1.atlanta.com;user=phone>
;tag=314159
Call-ID: 2xTb9vxSit55XU7p8@atlanta.com
CSeq: 1 ACK
Content-Length: 0
```

F13 ACK Proxy 1 -> NGW 1

```
ACK sip:+19725552222@ngw1.atlanta.com;user=phone SIP/2.0
Via: SIP/2.0/UDP ss1.atlanta.com:5060;branch=z9hG4bK2d4790.1
Via: SIP/2.0/UDP client.atlanta.com:5060;branch=z9hG4bK74bf9
;received=192.168.100.101
Max-Forwards: 69
From: BigGuy <sip:+13145551111@ss1.atlanta.com;user=phone>
;tag=9fxced76sl
To: LittleGuy <sip:+19725552222@ss1.atlanta.com;user=phone>
;tag=314159
Call-ID: 2xTb9vxSit55XU7p8@atlanta.com
CSeq: 1 ACK
Content-Length: 0
```

/\* User A Hangs Up with User B. \*/

F14 BYE A -> Proxy 1

```
BYE sip:+19725552222@ngw1.atlanta.com;user=phone SIP/2.0
Via: SIP/2.0/UDP client.atlanta.com:5060;branch=z9hG4bK74bf9
Max-Forwards: 70
Route: <sip:ss1.atlanta.com;lr>
From: BigGuy <sip:+13145551111@ss1.atlanta.com;user=phone>
;tag=9fxced76sl
To: LittleGuy <sip:+19725552222@ss1.atlanta.com;user=phone>
```

;tag=314159  
Call-ID: 2xTb9vXSit55XU7p8@atlanta.com

Johnston, et al.

Informational

[Page 96]



CSeq: 2 BYE  
Content-Length: 0

F15 BYE Proxy 1 -> NGW 1

BYE sip:+19725552222@ngw1.atlanta.com;user=phone SIP/2.0  
Via: SIP/2.0/UDP ss1.atlanta.com:5060;branch=z9hG4bK2d4790.1  
Via: SIP/2.0/UDP client.atlanta.com:5060;branch=z9hG4bK74bf9  
;received=192.168.100.101  
Max-Forwards: 69  
From: BigGuy <sip:+13145551111@ss1.atlanta.com;user=phone>  
;tag=9fxced76sl  
To: LittleGuy <sip:+19725552222@ss1.atlanta.com;user=phone>  
;tag=314159  
Call-ID: 2xTb9vxSit55XU7p8@atlanta.com  
CSeq: 2 BYE  
Content-Length: 0

F16 200 OK NGW 1 -> Proxy 1

SIP/2.0 200 OK  
Via: SIP/2.0/UDP ss1.atlanta.com:5060;branch=z9hG4bK2d4790.1  
;received=192.168.255.111  
Via: SIP/2.0/UDP client.atlanta.com:5060;branch=z9hG4bK74bf9  
;received=192.168.100.101  
From: BigGuy <sip:+13145551111@ss1.atlanta.com;user=phone>  
;tag=9fxced76sl  
To: LittleGuy <sip:+19725552222@ss1.atlanta.com;user=phone>  
;tag=314159  
Call-ID: 2xTb9vxSit55XU7p8@atlanta.com  
CSeq: 2 BYE  
Content-Length: 0

F17 200 OK Proxy 1 -> A

SIP/2.0 200 OK  
Via: SIP/2.0/UDP client.atlanta.com:5060;branch=z9hG4bK74bf9  
;received=192.168.100.101  
From: BigGuy <sip:+13145551111@ss1.atlanta.com;user=phone>  
;tag=9fxced76sl  
To: LittleGuy <sip:+19725552222@ss1.atlanta.com;user=phone>  
;tag=314159  
Call-ID: 2xTb9vxSit55XU7p8@atlanta.com  
CSeq: 2 BYE  
Content-Length: 0



REL  
CauseCode=16 Normal

F19 RLC B -> NGW 1

RLC



**4.1.1.2 Successful SIP to ISDN PBX call**

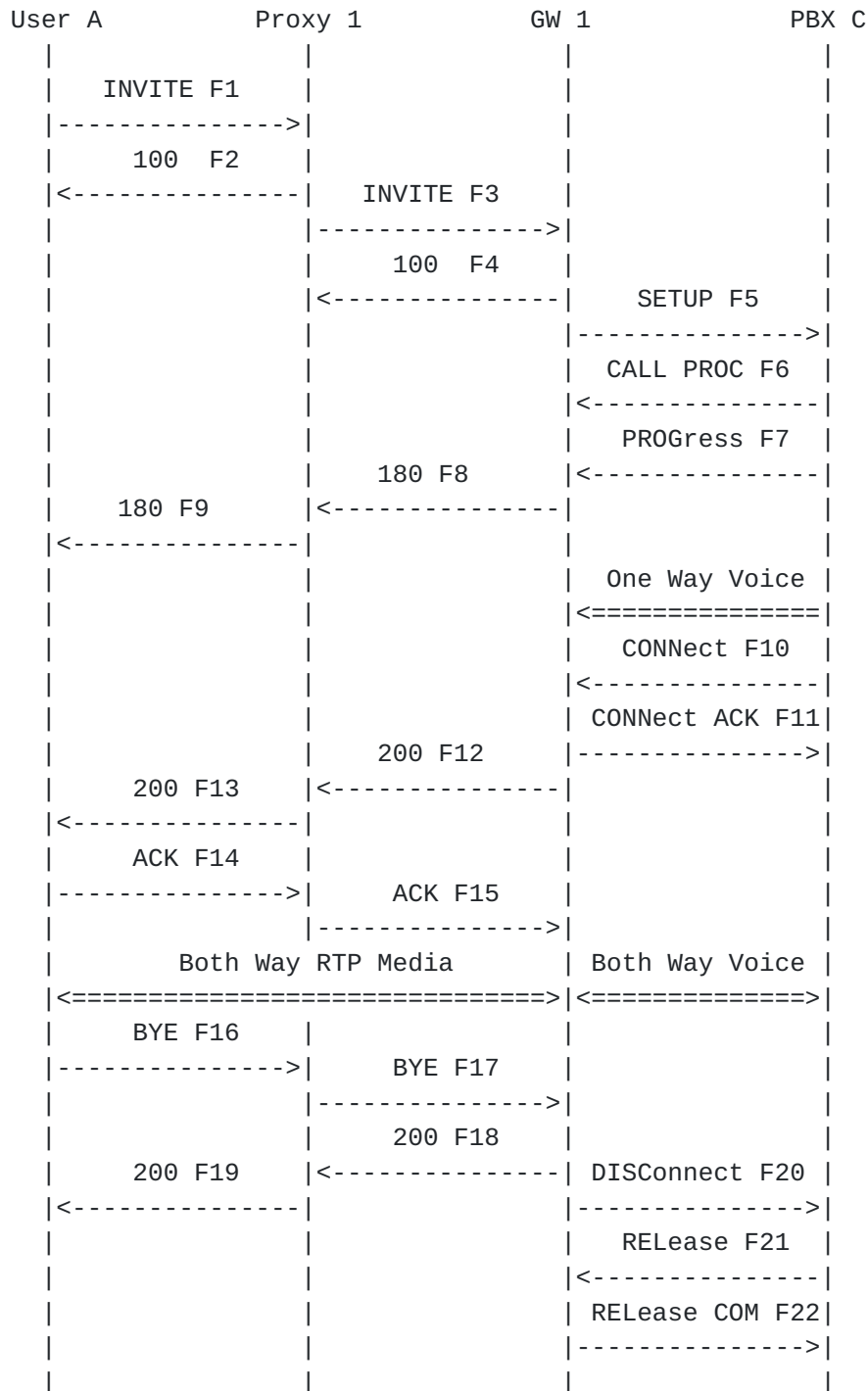

User A is a SIP device while User C is connected via a Gateway (GW 1) to a PBX. The PBX connection is via a ISDN trunk group. User A dials User C's telephone number (918-555-3333) which is globalized and put into a SIP URI.

The host portion of the Request-URI in the INVITE F3 is used to

identify the context (customer, trunk group, or line) in which the private number 444-3333 is valid. Otherwise, this INVITE message could get forwarded by GW 1 and the context of the digits could

become lost and the call unroutable.

Proxy 1 looks up the telephone number and locates the gateway that serves User C. User C is identified by its extension (444-3333) in the Request-URI sent to GW 1.

#### Message Details

F1 INVITE A -> Proxy 1

```
INVITE sip:+19185553333@ss1.atlanta.com;user=phone SIP/2.0
Via: SIP/2.0/UDP client.atlanta.com:5060;branch=z9hG4bK74bf9
Max-Forwards: 70
From: BigGuy <sip:+13145551111@ss1.atlanta.com;user=phone>
;tag=9fxced76sl
To: OtherGuy <sip:+19185553333@ss1.atlanta.com;user=phone>
Call-ID: 2xTb9vxSit55XU7p8@atlanta.com
CSeq: 2 INVITE
Contact: <sip:UserA@192.168.100.101>
Proxy-Authorization: Digest username="UserA",
realm="atlanta.com", nonce="qo0dc3a5ab22aa931904badfa1cf5j9h",
opaque="", uri="sip:+19185553333@ss1.atlanta.com;user=phone",
response="6c792f5c9fa360358b93c7fb826bf550"
Content-Type: application/sdp
Content-Length: 147
```

```
v=0
o=UserA 2890844526 2890844526 IN IP4 client.atlanta.com
s=-
c=IN IP4 192.168.100.101
t=0 0
m=audio 49172 RTP/AVP 0
a=rtpmap:0 PCMU/8000
```

F2 100 Trying Proxy 1 -> User A

```
SIP/2.0 100 Trying
Via: SIP/2.0/UDP client.atlanta.com:5060;branch=z9hG4bK74bf9
;received=192.168.100.101
From: BigGuy <sip:+13145551111@ss1.atlanta.com;user=phone>
;tag=9fxced76sl
To: OtherGuy <sip:+19185553333@ss1.atlanta.com;user=phone>
Call-ID: 2xTb9vxSit55XU7p8@atlanta.com
CSeq: 2 INVITE
Content-Length: 0
```

F3 INVITE Proxy 1 -> GW 1

Johnston, et al.

Informational

[Page 100]



```
INVITE sip:4443333@gw1.atlanta.com SIP/2.0
Via: SIP/2.0/UDP ss1.atlanta.com:5060;branch=z9hG4bK2d4790.1
Via: SIP/2.0/UDP client.atlanta.com:5060;branch=z9hG4bK74bf9
;received=192.168.100.101
Max-Forwards: 69
Record-Route: <sip:ss1.atlanta.com;lr>
From: BigGuy <sip:+13145551111@ss1.atlanta.com;user=phone>
;tag=9fxced76sl
To: OtherGuy <sip:+19185553333@ss1.atlanta.com;user=phone>
Call-ID: 2xTb9vxSit55XU7p8@atlanta.com
CSeq: 2 INVITE
Contact: <sip:UserA@192.168.100.101>
Content-Type: application/sdp
Content-Length: 147
```

```
v=0
o=UserA 2890844526 2890844526 IN IP4 client.atlanta.com
s=-
c=IN IP4 192.168.100.101
t=0 0
m=audio 49172 RTP/AVP 0
a=rtpmap:0 PCMU/8000
```

F4 100 Trying GW -> Proxy 1

```
SIP/2.0 100 Trying
Via: SIP/2.0/UDP ss1.atlanta.com:5060;branch=z9hG4bK2d4790.1
;received=192.168.255.111
From: BigGuy <sip:+13145551111@ss1.atlanta.com;user=phone>
;tag=9fxced76sl
To: OtherGuy <sip:+19185553333@ss1.atlanta.com;user=phone>
Call-ID: 2xTb9vxSit55XU7p8@atlanta.com
CSeq: 2 INVITE
Content-Length: 0
```

F5 SETUP GW 1 -> User C

```
Protocol discriminator=Q.931
Message type=SETUP
Bearer capability: Information transfer capability=0 (Speech) or 16
(3.1 kHz audio)
Channel identification=Preferred or exclusive B-channel
Progress indicator=1 (Call is not end-to-end ISDN;further call
progress information may be available inband)
Called party number:
Type of number unknown
Digits=444-3333
```

F6 CALL PROCeeding User C -> GW 1

Johnston, et al.

Informational

[Page 101]

Protocol discriminator=Q.931  
Message type=CALL PROC  
Channel identification=Exclusive B-channel

F7 PROGRESS User C -> GW 1

Protocol discriminator=Q.931  
Message type=PROG  
Progress indicator=1 (Call is not end-to-end ISDN;further call  
progress information may be available inband)

F8 180 Ringing GW 1 -> Proxy 1

SIP/2.0 180 Ringing  
Via: SIP/2.0/UDP ss1.atlanta.com:5060;branch=z9hG4bK2d4790.1  
;received=192.168.255.111  
Via: SIP/2.0/UDP client.atlanta.com:5060;branch=z9hG4bK74bf9  
;received=192.168.100.101  
Record-Route: <sip:ss1.atlanta.com;lr>  
From: BigGuy <sip:+13145551111@ss1.atlanta.com;user=phone>  
;tag=9fxced76sl  
To: OtherGuy <sip:+19185553333@ss1.atlanta.com;user=phone>  
;tag=314159  
Call-ID: 2xTb9vxSit55XU7p8@atlanta.com  
CSeq: 2 INVITE  
Contact: <sip:4443333@gw1.atlanta.com>  
Content-Length: 0

F9 180 Ringing Proxy 1 -> User A

SIP/2.0 180 Ringing  
Via: SIP/2.0/UDP client.atlanta.com:5060;branch=z9hG4bK74bf9  
;received=192.168.100.101  
Record-Route: <sip:ss1.atlanta.com;lr>  
From: BigGuy <sip:+13145551111@ss1.atlanta.com;user=phone>  
;tag=9fxced76sl  
To: OtherGuy <sip:+19185553333@ss1.atlanta.com;user=phone>  
;tag=314159  
Call-ID: 2xTb9vxSit55XU7p8@atlanta.com  
CSeq: 2 INVITE  
Contact: <sip:4443333@gw1.atlanta.com>  
Content-Length: 0

F10 CONNECT User C -> GW 1

Protocol discriminator=Q.931  
Message type=CONN

Johnston, et al.

Informational

[Page 102]

F11 CONNect ACK GW 1 -> User C

Protocol discriminator=Q.931  
Message type=CONN ACK

F12 200 OK GW 1 -> Proxy 1

SIP/2.0 200 OK  
Via: SIP/2.0/UDP ss1.atlanta.com:5060;branch=z9hG4bK2d4790.1  
;received=192.168.255.111  
Via: SIP/2.0/UDP client.atlanta.com:5060;branch=z9hG4bK74bf9  
;received=192.168.100.101  
Record-Route: <sip:ss1.atlanta.com;lr>  
From: BigGuy <sip:+13145551111@ss1.atlanta.com;user=phone>  
;tag=9fxced76sl  
To: OtherGuy <sip:+19185553333@ss1.atlanta.com;user=phone>  
;tag=314159  
Call-ID: 2xTb9vxSit55XU7p8@atlanta.com  
CSeq: 2 INVITE  
Contact: <sip:4443333@gw1.atlanta.com>  
Content-Type: application/sdp  
Content-Length: 140

v=0  
o=GW 2890844527 2890844527 IN IP4 gw1.atlanta.com  
s=-  
c=IN IP4 192.168.255.201  
t=0 0  
m=audio 3456 RTP/AVP 0  
a=rtpmap:0 PCMU/8000

F13 200 OK Proxy 1 -> User A

SIP/2.0 200 OK  
Via: SIP/2.0/UDP client.atlanta.com:5060;branch=z9hG4bK74bf9  
;received=192.168.100.101  
Record-Route: <sip:ss1.atlanta.com;lr>  
From: BigGuy <sip:+13145551111@ss1.atlanta.com;user=phone>  
;tag=9fxced76sl  
To: OtherGuy <sip:+19185553333@ss1.atlanta.com;user=phone>;tag=314159  
Call-ID: 2xTb9vxSit55XU7p8@atlanta.com  
CSeq: 2 INVITE  
Contact: <sip:4443333@gw1.atlanta.com>  
Content-Type: application/sdp  
Content-Length: 140

v=0

o=GW 2890844527 2890844527 IN IP4 gw1.atlanta.com

Johnston, et al.

Informational

[Page 103]

```
S=-
c=IN IP4 192.168.255.201
t=0 0
m=audio 3456 RTP/AVP 0
a=rtpmap:0 PCMU/8000
```

F14 ACK A -> Proxy 1

```
ACK sip:4443333@gw1.atlanta.com SIP/2.0
Via: SIP/2.0/UDP client.atlanta.com:5060;branch=z9hG4bK74bf9
Max-Forwards: 70
Route: <sip:ss1.atlanta.com;lr>
From: BigGuy <sip:+13145551111@ss1.atlanta.com;user=phone>
;tag=9fxced76sl
To: OtherGuy <sip:+19185553333@ss1.atlanta.com;user=phone>
;tag=314159
Call-ID: 2xTb9vxSit55XU7p8@atlanta.com
CSeq: 2 ACK
Content-Length: 0
```

F15 ACK Proxy 1 -> GW 1

```
ACK sip:4443333@gw1.atlanta.com SIP/2.0
Via: SIP/2.0/UDP ss1.atlanta.com:5060;branch=z9hG4bK2d4790.1
Via: SIP/2.0/UDP client.atlanta.com:5060;branch=z9hG4bK74bf9
;received=192.168.100.101
Max-Forwards: 69
From: BigGuy <sip:+13145551111@ss1.atlanta.com;user=phone>
;tag=9fxced76sl
To: OtherGuy <sip:+19185553333@ss1.atlanta.com;user=phone>
;tag=314159
Call-ID: 2xTb9vxSit55XU7p8@atlanta.com
CSeq: 2 ACK
Content-Length: 0
```

/\* User A Hangs Up with User B. \*/

F16 BYE A -> Proxy 1

```
BYE sip:4443333@gw1.atlanta.com SIP/2.0
Via: SIP/2.0/UDP client.atlanta.com:5060;branch=z9hG4bK74bf9
Max-Forwards: 70
Route: <sip:ss1.atlanta.com;lr>
From: BigGuy <sip:+13145551111@ss1.atlanta.com;user=phone>
;tag=9fxced76sl
To: OtherGuy <sip:+19185553333@ss1.atlanta.com;user=phone>
;tag=314159
```

Call-ID: 2xTb9vxSit55XU7p8@atlanta.com  
CSeq: 3 BYE

Johnston, et al.

Informational

[Page 104]



Content-Length: 0

F17 BYE Proxy 1 -> GW 1

BYE sip:4443333@gw1.atlanta.com SIP/2.0  
Via: SIP/2.0/UDP ss1.atlanta.com:5060;branch=z9hG4bK2d4790.1  
Via: SIP/2.0/UDP client.atlanta.com:5060;branch=z9hG4bK74bf9  
;received=192.168.100.101  
Max-Forwards: 69  
From: BigGuy <sip:+13145551111@ss1.atlanta.com;user=phone>  
;tag=9fxced76sl  
To: OtherGuy <sip:+19185553333@ss1.atlanta.com;user=phone>  
;tag=314159  
Call-ID: 2xTb9vxSit55XU7p8@atlanta.com  
CSeq: 3 BYE  
Content-Length: 0

F18 200 OK GW 1 -> Proxy 1

SIP/2.0 200 OK  
Via: SIP/2.0/UDP ss1.atlanta.com:5060;branch=z9hG4bK2d4790.1  
;received=192.168.255.111  
Via: SIP/2.0/UDP client.atlanta.com:5060;branch=z9hG4bK74bf9  
;received=192.168.100.101  
From: BigGuy <sip:+13145551111@ss1.atlanta.com;user=phone>  
;tag=9fxced76sl  
To: OtherGuy <sip:+19185553333@ss1.atlanta.com;user=phone>  
;tag=314159  
Call-ID: 2xTb9vxSit55XU7p8@atlanta.com  
CSeq: 3 BYE  
Content-Length: 0

F19 200 OK Proxy 1 -> A

SIP/2.0 200 OK  
Via: SIP/2.0/UDP client.atlanta.com:5060;branch=z9hG4bK74bf9  
;received=192.168.100.101  
From: BigGuy <sip:+13145551111@ss1.atlanta.com;user=phone>  
;tag=9fxced76sl  
To: OtherGuy <sip:+19185553333@ss1.atlanta.com;user=phone>  
;tag=314159  
Call-ID: 2xTb9vxSit55XU7p8@atlanta.com  
CSeq: 3 BYE  
Content-Length: 0

F20 DISConnect GW 1 -> User C

Protocol discriminator=Q.931

Johnston, et al.

Informational

[Page 105]

Message type=DISC  
Cause=16 (Normal clearing)

F21 RELease User C -> GW 1

Protocol discriminator=Q.931  
Message type=REL

F22 RELease COMplete GW 1 -> User C

Protocol discriminator=Q.931  
Message type=REL COM



**4.1.1.3 Successful SIP to ISUP PSTN call with overflow**

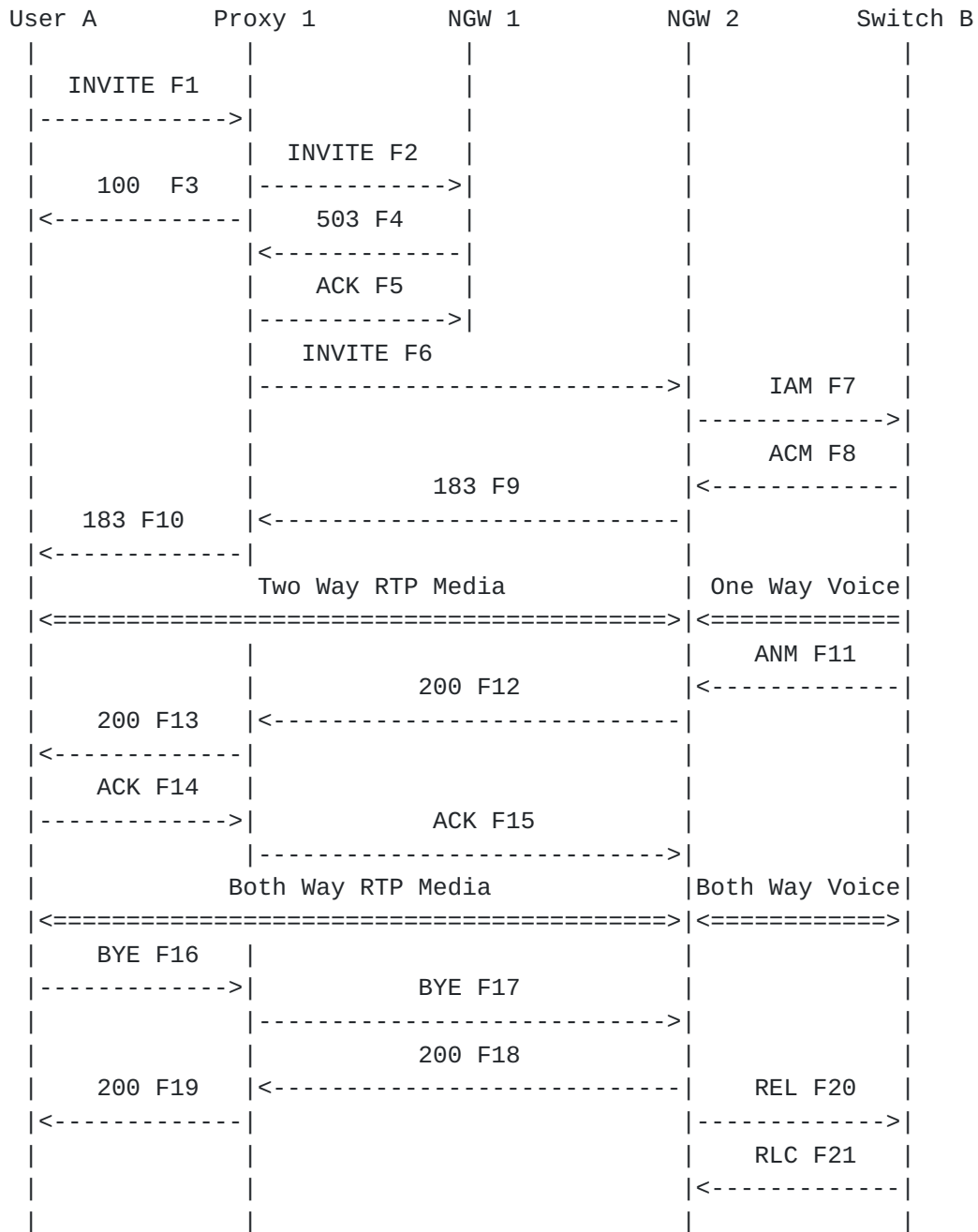

User A calls User B through Proxy 1. Proxy 1 tries to route to a Network Gateway NGW 1. NGW 1 is not available and responds with a 503 Service Unavailable (F4). The call is then routed to Network Gateway NGW 2. User B answers the call. The call is terminated when User A disconnects the call. NGW 2 and User B's telephone switch use ANSI ISUP signaling.

Message Details

F1 INVITE A -> Proxy 1

Johnston, et al.

Informational

[Page 107]

```
INVITE sip:+19725552222@ss1.atlanta.com;user=phone SIP/2.0
Via: SIP/2.0/UDP client.atlanta.com:5060;branch=z9hG4bK74bf9
Max-Forwards: 70
From: BigGuy <sip:+13145551111@ss1.atlanta.com;user=phone>
;tag=9fxced76sl
To: LittleGuy <sip:+19725552222@ss1.atlanta.com;user=phone>
Call-ID: 2xTb9vxSit55XU7p8@atlanta.com
CSeq: 1 INVITE
Contact: <sip:UserA@192.168.100.101>
Proxy-Authorization: Digest username="UserA",
realm="atlanta.com", nonce="b59311c3ba05b401cf80b2a2c5ac51b0",
opaque="", uri="sip:+19725552222@ss1.atlanta.com;user=phone",
response="ba6ab44923fa2614b28e3e3957789ab0"
Content-Type: application/sdp
Content-Length: 147
```

```
v=0
o=UserA 2890844526 2890844526 IN IP4 client.atlanta.com
s=-
c=IN IP4 192.168.100.101
t=0 0
m=audio 49172 RTP/AVP 0
a=rtpmap:0 PCMU/8000
```

```
/* Proxy 1 uses a Location Service function to determine where B is
located. Proxy 1 receives a primary route NGW 1 and a secondary
route NGW 2. NGW 1 is tried first */
```

```
F2 INVITE Proxy 1 -> NGW 1
```

```
INVITE sip:+19725552222@ngw1.atlanta.com;user=phone SIP/2.0
Via: SIP/2.0/UDP ss1.atlanta.com:5060;branch=z9hG4bK2d4790.1
Via: SIP/2.0/UDP client.atlanta.com:5060;branch=z9hG4bK74bf9
;received=192.168.100.101
Max-Forwards: 69
Record-Route: <sip:ss1.atlanta.com;lr>
From: BigGuy <sip:+13145551111@ss1.atlanta.com;user=phone>
;tag=9fxced76sl
To: LittleGuy <sip:+19725552222@ss1.atlanta.com;user=phone>
Call-ID: 2xTb9vxSit55XU7p8@atlanta.com
CSeq: 1 INVITE
Contact: <sip:UserA@192.168.100.101>
Content-Type: application/sdp
Content-Length: 147
```

```
v=0
o=UserA 2890844526 2890844526 IN IP4 client.atlanta.com
s=-
```

c=IN IP4 192.168.100.101  
t=0 0  
m=audio 49172 RTP/AVP 0

Johnston, et al.

Informational

[Page 108]



a=rtpmap:0 PCMU/8000

F3 100 Trying Proxy 1 -> User A

SIP/2.0 100 Trying

Via: SIP/2.0/UDP ss1.atlanta.com:5060;branch=z9hG4bK2d4790.1  
;received=192.168.255.111

Via: SIP/2.0/UDP client.atlanta.com:5060;branch=z9hG4bK74bf9  
;received=192.168.100.101

From: BigGuy <sip:+13145551111@ss1.atlanta.com;user=phone>  
;tag=9fxced76sl

To: LittleGuy <sip:+19725552222@ss1.atlanta.com;user=phone>

Call-ID: 2xTb9vxSit55XU7p8@atlanta.com

CSeq: 1 INVITE

Content-Length: 0

F4 503 Service Unavailable NGW 1 -> Proxy 1

SIP/2.0 503 Service Unavailable

Via: SIP/2.0/UDP ss1.atlanta.com:5060;branch=z9hG4bK2d4790.1  
;received=192.168.255.111

Via: SIP/2.0/UDP client.atlanta.com:5060;branch=z9hG4bK74bf9  
;received=192.168.100.101

Record-Route: <sip:ss1.atlanta.com;lr>

From: BigGuy <sip:+13145551111@ss1.atlanta.com;user=phone>  
;tag=9fxced76sl

To: LittleGuy <sip:+19725552222@ss1.atlanta.com;user=phone>  
;tag=123456789

Call-ID: 2xTb9vxSit55XU7p8@atlanta.com

CSeq: 1 INVITE

Content-Length: 0

F5 ACK Proxy 1 -> NGW 1

ACK sip:+19725552222@ngw1.atlanta.com;user=phone SIP/2.0

Via: SIP/2.0/UDP ss1.atlanta.com:5060;branch=z9hG4bK2d4790.1

Max-Forwards: 70

From: BigGuy <sip:+13145551111@ss1.atlanta.com;user=phone>  
;tag=9fxced76sl

To: LittleGuy <sip:+19725552222@ss1.atlanta.com>;user=phone>  
;tag=123456789

Call-ID: 2xTb9vxSit55XU7p8@atlanta.com

CSeq: 1 ACK

Content-Length: 0

/\* Proxy 1 now tries secondary route to NGW 2 \*/

F6 INVITE Proxy 1 -> NGW 2

Johnston, et al.

Informational

[Page 109]

```
INVITE sip:+19725552222@ngw2.atlanta.com;user=phone SIP/2.0
Via: SIP/2.0/UDP ss1.atlanta.com:5060;branch=z9hG4bK2d4790.2
Via: SIP/2.0/UDP client.atlanta.com:5060;branch=z9hG4bK74bf9
;received=192.168.100.101
Max-Forwards: 69
Record-Route: <sip:ss1.atlanta.com;lr>
From: BigGuy <sip:+13145551111@ss1.atlanta.com;user=phone>
;tag=9fxced76sl
To: LittleGuy <sip:+19725552222@ss1.atlanta.com;user=phone>
Call-ID: 2xTb9vxSit55XU7p8@atlanta.com
CSeq: 1 INVITE
Contact: <sip:UserA@192.168.100.101>
Content-Type: application/sdp
Content-Length: 147
```

```
v=0
o=UserA 2890844526 2890844526 IN IP4 client.atlanta.com
s=-
c=IN IP4 192.168.100.101
t=0 0
m=audio 49172 RTP/AVP 0
a=rtpmap:0 PCMU/8000
```

F7 IAM NGW 2 -> User B

```
IAM
CdPN=972-555-2222,NPI=E.164,NOA=National
CgPN=314-555-1111,NPI=E.164,NOA=National
```

F8 ACM User B -> NGW 2

ACM

F9 183 Session Progress NGW 2 -> Proxy 1

```
SIP/2.0 183 Session Progress
Via: SIP/2.0/UDP ss1.atlanta.com:5060;branch=z9hG4bK2d4790.2
;received=192.168.255.111
Via: SIP/2.0/UDP client.atlanta.com:5060;branch=z9hG4bK74bf9
;received=192.168.100.101
Record-Route: <sip:ss1.atlanta.com;lr>
From: BigGuy <sip:+13145551111@ss1.atlanta.com;user=phone>
;tag=9fxced76sl
To: LittleGuy <sip:+19725552222@ss1.atlanta.com;user=phone>
;tag=314159
Call-ID: 2xTb9vxSit55XU7p8@atlanta.com
```

CSeq: 1 INVITE

Contact: <sip:+19725552222@ngw2.atlanta.com;user=phone>

Johnston, et al.

Informational

[Page 110]

Content-Type: application/sdp  
Content-Length: 141

v=0  
o=GW 2890844527 2890844527 IN IP4 ngw2.atlanta.com  
s=-  
c=IN IP4 192.168.255.102  
t=0 0  
m=audio 3456 RTP/AVP 0  
a=rtpmap:0 PCMU/8000

/\* RTP packets are sent by GW to A for audio (e.g. ring tone) \*/

F10 183 Session Progress Proxy 1 -> User A

SIP/2.0 183 Session Progress  
Via: SIP/2.0/UDP client.atlanta.com:5060;branch=z9hG4bK74bf9  
;received=192.168.100.101  
Record-Route: <sip:ss1.atlanta.com;lr>  
From: BigGuy <sip:+13145551111@ss1.atlanta.com;user=phone>  
;tag=9fxced76s1  
To: LittleGuy <sip:+19725552222@ss1.atlanta.com;user=phone>  
;tag=314159  
Call-ID: 2xTb9vxSit55XU7p8@atlanta.com  
CSeq: 1 INVITE  
Contact: <sip:+19725552222@ngw2.atlanta.com;user=phone>  
Content-Type: application/sdp  
Content-Length: 141

v=0  
o=GW 2890844527 2890844527 IN IP4 ngw2.atlanta.com  
s=-  
c=IN IP4 192.168.255.102  
t=0 0  
m=audio 3456 RTP/AVP 0  
a=rtpmap:0 PCMU/8000

F11 ANM User B -> NGW 2

ANM

F12 200 OK NGW 2 -> Proxy 1

SIP/2.0 200 OK  
Via: SIP/2.0/UDP ss1.atlanta.com:5060;branch=z9hG4bK2d4790.2  
;received=192.168.255.111  
Via: SIP/2.0/UDP client.atlanta.com:5060;branch=z9hG4bK74bf9

;received=192.168.100.101  
Record-Route: <sip:ss1.atlanta.com;lr>

Johnston, et al.

Informational

[Page 111]

From: BigGuy <sip:+13145551111@ss1.atlanta.com;user=phone>  
;tag=9fxced76s1  
To: LittleGuy <sip:+19725552222@ss1.atlanta.com;user=phone>  
;tag=314159  
Call-ID: 2xTb9vxSit55XU7p8@atlanta.com  
CSeq: 1 INVITE  
Contact: <sip:+19725552222@ngw2.atlanta.com;user=phone>  
Content-Type: application/sdp  
Content-Length: 141

v=0  
o=GW 2890844527 2890844527 IN IP4 ngw2.atlanta.com  
s=-  
c=IN IP4 192.168.255.102  
t=0 0  
m=audio 3456 RTP/AVP 0  
a=rtpmap:0 PCMU/8000

F13 200 OK Proxy 1 -> User A

SIP/2.0 200 OK  
Via: SIP/2.0/UDP client.atlanta.com:5060;branch=z9hG4bK74bf9  
;received=192.168.100.101  
Record-Route: <sip:ss1.atlanta.com;lr>  
From: BigGuy <sip:+13145551111@ss1.atlanta.com;user=phone>  
;tag=9fxced76s1  
To: LittleGuy <sip:+19725552222@ss1.atlanta.com;user=phone>  
;tag=314159  
Call-ID: 2xTb9vxSit55XU7p8@atlanta.com  
CSeq: 1 INVITE  
Contact: <sip:+19725552222@ngw2.atlanta.com;user=phone>  
Content-Type: application/sdp  
Content-Length: 141

v=0  
o=GW 2890844527 2890844527 IN IP4 ngw2.atlanta.com  
s=-  
c=IN IP4 192.168.255.102  
t=0 0  
m=audio 3456 RTP/AVP 0  
a=rtpmap:0 PCMU/8000

F14 ACK A -> Proxy 1

ACK sip:+19725552222@ngw2.atlanta.com;user=phone SIP/2.0  
Via: SIP/2.0/UDP client.atlanta.com:5060;branch=z9hG4bK74bf9  
Max-Forwards: 70

Route: <ss1.atlanta.com;lr>

From: BigGuy <sip:+13145551111@ss1.atlanta.com;user=phone>  
;tag=9fxced76sl

Johnston, et al.

Informational

[Page 112]



To: LittleGuy <sip:+19725552222@ss1.atlanta.com;user=phone>  
;tag=314159  
Call-ID: 2xTb9vxSit55XU7p8@atlanta.com  
CSeq: 1 ACK  
Content-Length: 0

F15 ACK Proxy 1 -> NGW 2

ACK sip:+19725552222@ngw2.atlanta.com;user=phone SIP/2.0  
Via: SIP/2.0/UDP ss1.atlanta.com:5060;branch=z9hG4bK2d4790.2  
Via: SIP/2.0/UDP client.atlanta.com:5060;branch=z9hG4bK74bf9  
;received=192.168.100.101  
Max-Forwards: 69  
From: BigGuy <sip:+13145551111@ss1.atlanta.com;user=phone>  
;tag=9fxced76sl  
To: LittleGuy <sip:+19725552222@ss1.atlanta.com;user=phone>  
;tag=314159  
Call-ID: 2xTb9vxSit55XU7p8@atlanta.com  
CSeq: 1 ACK  
Content-Length: 0

/\* RTP streams are established between A and B(via the GW) \*/

/\* User A Hangs Up with User B. \*/

F16 BYE A -> Proxy 1

BYE sip:+19725552222@ngw2.atlanta.com;user=phone SIP/2.0  
Via: SIP/2.0/UDP client.atlanta.com:5060;branch=z9hG4bK74bf9  
Max-Forwards: 70  
Route: <ss1.atlanta.com;lr>  
From: BigGuy <sip:+13145551111@ss1.atlanta.com;user=phone>  
;tag=9fxced76sl  
To: LittleGuy <sip:+19725552222@ss1.atlanta.com;user=phone>  
;tag=314159  
Call-ID: 2xTb9vxSit55XU7p8@atlanta.com  
CSeq: 2 BYE  
Content-Length: 0

F17 BYE Proxy 1 -> NGW 2

BYE sip:+19725552222@ngw2.atlanta.com;user=phone SIP/2.0  
Via: SIP/2.0/UDP ss1.atlanta.com:5060;branch=z9hG4bK2d4790.2  
Via: SIP/2.0/UDP client.atlanta.com:5060;branch=z9hG4bK74bf9  
;received=192.168.100.101  
Max-Forwards: 69  
From: BigGuy <sip:+13145551111@ss1.atlanta.com;user=phone>

;tag=9fxced76sl  
To: LittleGuy <sip:+19725552222@ss1.atlanta.com;user=phone>

Johnston, et al.

Informational

[Page 113]

;tag=314159  
Call-ID: 2xTb9vxSit55XU7p8@atlanta.com  
CSeq: 2 BYE  
Content-Length: 0

F18 200 OK NGW 2 -> Proxy 1

SIP/2.0 200 OK  
Via: SIP/2.0/UDP ss1.atlanta.com:5060;branch=z9hG4bK2d4790.2  
;received=192.168.255.111  
Via: SIP/2.0/UDP client.atlanta.com:5060;branch=z9hG4bK74bf9  
;received=192.168.100.101  
From: BigGuy <sip:+13145551111@ss1.atlanta.com;user=phone>  
;tag=9fxced76sl  
To: LittleGuy <sip:+19725552222@ss1.atlanta.com;user=phone>  
;tag=314159  
Call-ID: 2xTb9vxSit55XU7p8@atlanta.com  
CSeq: 2 BYE  
Content-Length: 0

F19 200 OK Proxy 1 -> User A

SIP/2.0 200 OK  
Via: SIP/2.0/UDP client.atlanta.com:5060;branch=z9hG4bK74bf9  
;received=192.168.100.101  
From: BigGuy <sip:+13145551111@ss1.atlanta.com;user=phone>  
;tag=9fxced76sl  
To: LittleGuy <sip:+19725552222@ss1.atlanta.com;user=phone>  
;tag=314159  
Call-ID: 2xTb9vxSit55XU7p8@atlanta.com  
CSeq: 2 BYE  
Content-Length: 0

F20 REL NGW 2 -> B

REL  
CauseCode=16 Normal

F21 RLC B -> NGW 2

RLC



## **4.2 Failure Scenarios**

In these failure scenarios, the call does not complete. In most cases, however, a media stream is still setup. This is due to the fact that most failures in dialing to the PSTN result in in-band tones (busy, reorder tones or announcements - "The number you have dialed has changed. The new number is..."). The 183 Session Progress response containing SDP media information is used to setup this early media path so that the caller User A knows the final disposition of the call.

The media stream is either terminated by the caller after the tone or announcement has been heard and understood, or by the Gateway after a timer expires.

In other failure scenarios, a SS7 Release with Cause Code is mapped to a SIP response. In these scenarios, the early media path is not used, but the actual failure code is conveyed to the caller by the SIP User Agent Client.



**4.2.1 Unsuccessful SIP to PSTN call: Treatment from PSTN**

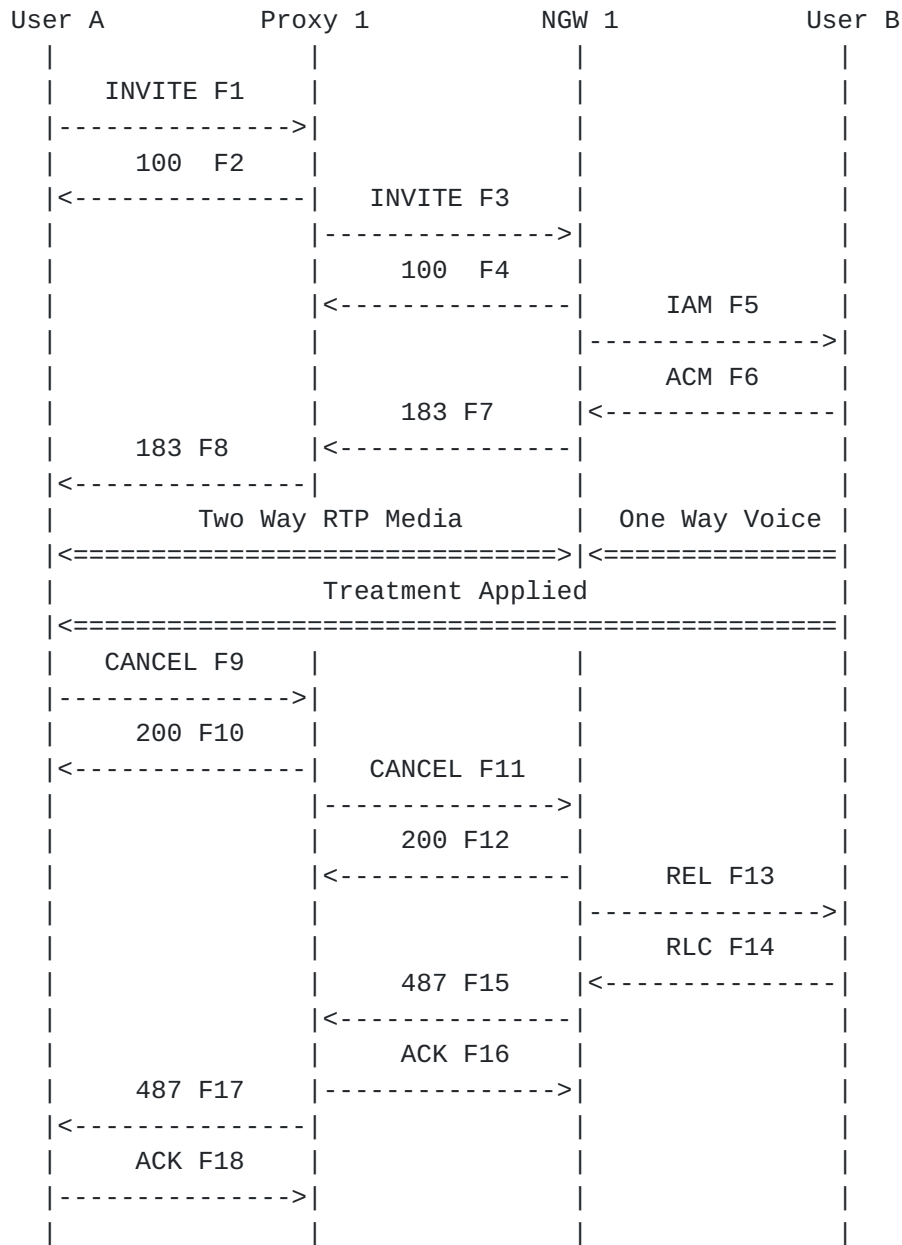

User A calls User B in the PSTN through a proxy server Proxy 1 and a Network Gateway NGW 1. The call is rejected by the PSTN with an in-band treatment (tone or recording) played. User A hears the treatment and then hangs up, which results in a CANCEL (F9) being sent to terminate the call. (A BYE is not sent since no final response was ever received by User A.)

Message Details

F1 INVITE A -> Proxy 1

INVITE sip:+19725552222@ss1.atlanta.com;user=phone SIP/2.0

Johnston, et al.

Informational

[Page 116]



```
Via: SIP/2.0/UDP client.atlanta.com:5060;branch=z9hG4bK74bf9
Max-Forwards: 70
From: BigGuy <sip:+13145551111@ss1.atlanta.com;user=phone>
;tag=9fxced76sl
To: LittleGuy <sip:+19725552222@ss1.atlanta.com;user=phone>
Call-ID: 2xTb9vxSit55XU7p8@atlanta.com
CSeq: 1 INVITE
Contact: <sip:UserA@192.168.100.101>
Proxy-Authorization: Digest username="UserA",
realm="atlanta.com", nonce="01cf8311c3b0b2a2c5ac51bb59a05b40",
opaque="", uri="sip:+19725552222@ss1.atlanta.com;user=phone",
response="e178fbe430e6680a1690261af8831f40"
Content-Type: application/sdp
Content-Length: 147
```

```
v=0
o=UserA 2890844526 2890844526 IN IP4 client.atlanta.com
s=-
c=IN IP4 192.168.100.101
t=0 0
m=audio 49172 RTP/AVP 0
a=rtpmap:0 PCMU/8000
```

F2 100 Trying Proxy 1 -> A

```
SIP/2.0 100 Trying
Via: SIP/2.0/UDP client.atlanta.com:5060;branch=z9hG4bK74bf9
;received=192.168.100.101
From: BigGuy <sip:+13145551111@ss1.atlanta.com;user=phone>
;tag=9fxced76sl
To: LittleGuy <sip:+19725552222@ss1.atlanta.com;user=phone>
Call-ID: 2xTb9vxSit55XU7p8@atlanta.com
CSeq: 1 INVITE
Content-Length: 0
```

```
/* Proxy 1 uses a Location Service function to determine where B is
located. Based upon location analysis the call is forwarded to NGW
1. Client for A prepares to receive data on port 49172 from the
network. */
```

F3 INVITE Proxy 1 -> NGW 1

```
INVITE sip:+19725552222@ngw1.atlanta.com;user=phone SIP/2.0
Via: SIP/2.0/UDP ss1.atlanta.com:5060;branch=z9hG4bK2d4790.1
Via: SIP/2.0/UDP client.atlanta.com:5060;branch=z9hG4bK74bf9
;received=192.168.100.101
Max-Forwards: 69
```

Record-Route: <sip:ss1.atlanta.com;lr>  
From: BigGuy <sip:+13145551111@ss1.atlanta.com;user=phone>  
;tag=9fxced76sl

Johnston, et al.

Informational

[Page 117]

To: LittleGuy <sip:+19725552222@ss1.atlanta.com;user=phone>  
Call-ID: 2xTb9vxSit55XU7p8@atlanta.com  
CSeq: 1 INVITE  
Contact: <sip:UserA@192.168.100.101>  
Content-Type: application/sdp  
Content-Length: 147

v=0  
o=UserA 2890844526 2890844526 IN IP4 client.atlanta.com  
s=-  
c=IN IP4 192.168.100.101  
t=0 0  
m=audio 49172 RTP/AVP 0  
a=rtpmap:0 PCMU/8000

F4 100 Trying NGW 1 -> Proxy 1

SIP/2.0 100 Trying  
Via: SIP/2.0/UDP ss1.atlanta.com:5060;branch=z9hG4bK2d4790.1  
;received=192.168.255.111  
Via: SIP/2.0/UDP client.atlanta.com:5060;branch=z9hG4bK74bf9  
;received=192.168.100.101  
From: BigGuy <sip:+13145551111@ss1.atlanta.com;user=phone>  
;tag=9fxced76sl  
To: LittleGuy <sip:+19725552222@ss1.atlanta.com;user=phone>  
Call-ID: 2xTb9vxSit55XU7p8@atlanta.com  
CSeq: 1 INVITE  
Content-Length: 0

F5 IAM NGW 1 -> User B

IAM  
CdPN=972-555-2222,NPI=E.164,NOA=National  
CgPN=314-555-1111,NPI=E.164,NOA=National

F6 ACM User B -> NGW 1

ACM

F7 183 Session Progress NGW 1 -> Proxy 1

SIP/2.0 183 Session Progress  
Via: SIP/2.0/UDP ss1.atlanta.com:5060;branch=z9hG4bK2d4790.1  
;received=192.168.255.111  
Via: SIP/2.0/UDP client.atlanta.com:5060;branch=z9hG4bK74bf9  
;received=192.168.100.101

Record-Route: <sip:ss1.atlanta.com;lr>

From: BigGuy <sip:+13145551111@ss1.atlanta.com;user=phone>

Johnston, et al.

Informational

[Page 118]

```
;tag=9fxced76s1
To: LittleGuy <sip:+19725552222@ss1.atlanta.com;user=phone>
;tag=314159
Call-ID: 2xTb9vxSit55XU7p8@atlanta.com
CSeq: 1 INVITE
Contact: <sip:+19725552222@ngw1.atlanta.com;user=phone>
Content-Type: application/sdp
Content-Length: 141
```

```
v=0
o=GW 2890844527 2890844527 IN IP4 ngw1.atlanta.com
s=-
c=IN IP4 192.168.255.101
t=0 0
m=audio 3456 RTP/AVP 0
a=rtpmap:0 PCMU/8000
```

F8 183 Session Progress Proxy 1 -> User A

```
SIP/2.0 183 Session Progress
Via: SIP/2.0/UDP client.atlanta.com:5060;branch=z9hG4bK74bf9
;received=192.168.100.101
Record-Route: <sip:ss1.atlanta.com;lr>
From: BigGuy <sip:+13145551111@ss1.atlanta.com;user=phone>
;tag=9fxced76s1
To: LittleGuy <sip:+19725552222@ss1.atlanta.com;user=phone>
;tag=314159
Call-ID: 2xTb9vxSit55XU7p8@atlanta.com
CSeq: 1 INVITE
Contact: <sip:+19725552222@ngw1.atlanta.com;user=phone>
Content-Type: application/sdp
Content-Length: 141
```

```
v=0
o=GW 2890844527 2890844527 IN IP4 ngw1.atlanta.com
s=-
c=IN IP4 192.168.255.101
t=0 0
m=audio 3456 RTP/AVP 0
a=rtpmap:0 PCMU/8000
```

/\* Caller hears the recorded announcement, then hangs up \*/

F9 CANCEL A -> Proxy 1

```
CANCEL sip:+19725552222@ss1.atlanta.com;user=phone SIP/2.0
Via: SIP/2.0/UDP client.atlanta.com:5060;branch=z9hG4bK74bf9
Max-Forwards: 70
```

From: BigGuy <sip:+13145551111@ss1.atlanta.com;user=phone>  
;tag=9fxced76sl

Johnston, et al.

Informational

[Page 119]

To: LittleGuy <sip:+19725552222@ss1.atlanta.com;user=phone>  
Call-ID: 2xTb9vxSit55XU7p8@atlanta.com  
CSeq: 1 CANCEL  
Content-Length: 0

F10 200 OK Proxy 1 -> A

SIP/2.0 200 OK  
Via: SIP/2.0/UDP client.atlanta.com:5060;branch=z9hG4bK74bf9  
;received=192.168.100.101  
From: BigGuy <sip:+13145551111@ss1.atlanta.com;user=phone>  
;tag=9fxced76s1  
To: LittleGuy <sip:+19725552222@ss1.atlanta.com;user=phone>  
Call-ID: 2xTb9vxSit55XU7p8@atlanta.com  
CSeq: 1 CANCEL  
Content-Length: 0

F11 CANCEL Proxy 1 -> NGW 1

CANCEL sip:+19725552222@ngw1.atlanta.com;user=phone SIP/2.0  
Via: SIP/2.0/UDP ss1.atlanta.com:5060;branch=z9hG4bK2d4790.1  
Max-Forwards: 70  
From: BigGuy <sip:+13145551111@ss1.atlanta.com;user=phone>  
;tag=9fxced76s1  
To: LittleGuy <sip:+19725552222@ss1.atlanta.com;user=phone>  
Call-ID: 2xTb9vxSit55XU7p8@atlanta.com  
CSeq: 1 CANCEL  
Content-Length: 0

F12 200 OK NGW 1 -> Proxy 1

SIP/2.0 200 OK  
Via: SIP/2.0/UDP ss1.atlanta.com:5060;branch=z9hG4bK2d4790.1  
;received=192.168.255.111  
From: BigGuy <sip:+13145551111@ss1.atlanta.com;user=phone>  
;tag=9fxced76s1  
To: LittleGuy <sip:+19725552222@ss1.atlanta.com;user=phone>  
Call-ID: 2xTb9vxSit55XU7p8@atlanta.com  
CSeq: 1 CANCEL  
Content-Length: 0

F13 REL NGW 1 -> B

REL  
CauseCode=18 No user responding

F14 RLC B -> NGW 1

Johnston, et al.

Informational

[Page 120]



RLC

F15 487 Request Terminated NGW 1 -> Proxy 1

SIP/2.0 487 Request Terminated  
Via: SIP/2.0/UDP ss1.atlanta.com:5060;branch=z9hG4bK2d4790.1  
;received=192.168.255.111  
Via: SIP/2.0/UDP client.atlanta.com:5060;branch=z9hG4bK74bf9  
;received=192.168.100.101  
From: BigGuy <sip:+13145551111@ss1.atlanta.com;user=phone>  
;tag=9fxced76sl  
To: LittleGuy <sip:+19725552222@ss1.atlanta.com;user=phone>  
;tag=314159  
Call-ID: 2xTb9vxSit55XU7p8@atlanta.com  
CSeq: 1 INVITE  
Content-Length: 0

F16 ACK Proxy 1 -> NGW 1

ACK sip:+19725552222@ngw1.atlanta.com;user=phone SIP/2.0  
Via: SIP/2.0/UDP ss1.atlanta.com:5060;branch=z9hG4bK2d4790.1  
Max-Forwards: 70  
From: BigGuy <sip:+13145551111@ss1.atlanta.com;user=phone>  
;tag=9fxced76sl  
To: LittleGuy <sip:+19725552222@ss1.atlanta.com;user=phone>  
;tag=314159  
Call-ID: 2xTb9vxSit55XU7p8@atlanta.com  
CSeq: 1 ACK  
Content-Length: 0

F17 487 Request Terminated Proxy 1 -> A

SIP/2.0 487 Request Terminated  
Via: SIP/2.0/UDP client.atlanta.com:5060;branch=z9hG4bK74bf9  
;received=192.168.100.101  
From: BigGuy <sip:+13145551111@ss1.atlanta.com;user=phone>  
;tag=9fxced76sl  
To: LittleGuy <sip:+19725552222@ss1.atlanta.com;user=phone>  
;tag=314159  
Call-ID: 2xTb9vxSit55XU7p8@atlanta.com  
CSeq: 1 INVITE  
Content-Length: 0

F18 ACK A -> Proxy 1

ACK sip:+19725552222@ss1.atlanta.com;user=phone SIP/2.0  
Via: SIP/2.0/UDP client.atlanta.com:5060;branch=z9hG4bK74bf9

Johnston, et al.

Informational

[Page 121]

```
Max-Forwards: 70
From: BigGuy <sip:+13145551111@ss1.atlanta.com;user=phone>
;tag=9fxced76s1
To: LittleGuy <sip:+19725552222@ss1.atlanta.com;user=phone>
;tag=314159
Call-ID: 2xTb9vxSit55XU7p8@atlanta.com
CSeq: 1 ACK
Content-Length: 0
```



**4.2.2 Unsuccessful SIP to PSTN: REL w/Cause from PSTN**

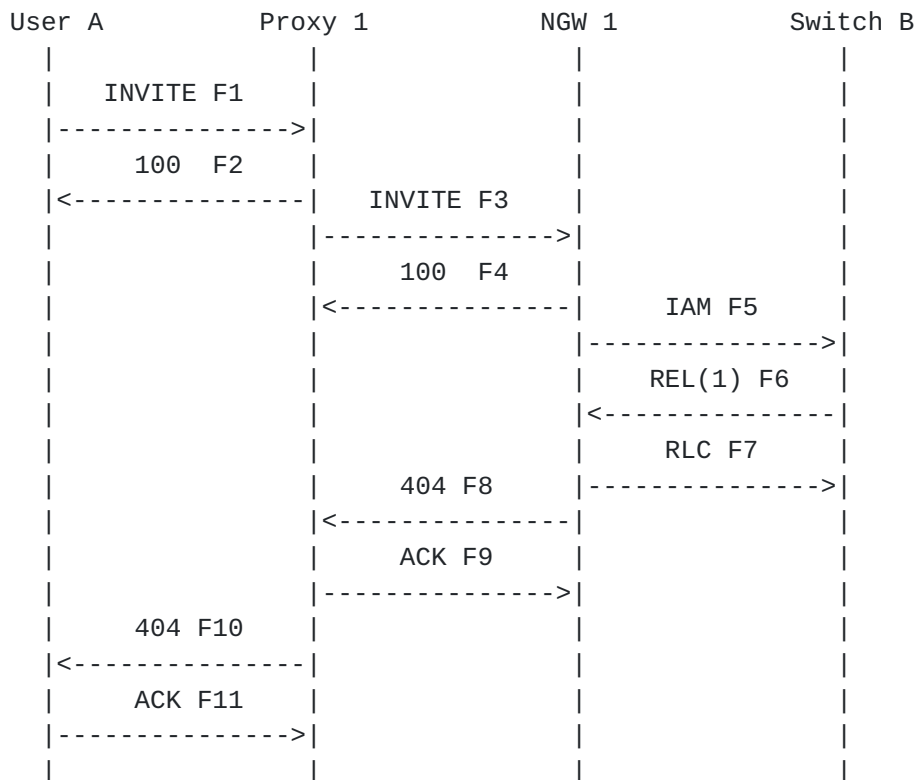

User A calls PSTN User B through a Proxy Server Proxy 1 and a Network Gateway NGW 1. The call is rejected by the PSTN with a ANSI ISUP Release message REL containing a specific Cause code. This cause value (1) is mapped by the Gateway to a SIP 404 Address Incomplete response which is proxied back to User A. For more details of ISUP cause value to SIP responses refer to [[SIP-ISUP](#)].

Message Details

F1 INVITE A -> Proxy 1

```

INVITE sip:+44-1234@ss1.atlanta.com;user=phone SIP/2.0
Via: SIP/2.0/UDP client.atlanta.com:5060;branch=z9hG4bK74bf9
Max-Forwards: 70
From: BigGuy <sip:+13145551111@ss1.atlanta.com;user=phone>
;tag=9fxced76s1
To: LittleGuy <sip:+44-1234@ss1.atlanta.com;user=phone>
Call-ID: 2xTb9vxSit55XU7p8@atlanta.com
CSeq: 1 INVITE
Contact: <sip:UserA@192.168.100.101>
Proxy-Authorization: Digest username="UserA",
realm="atlanta.com", nonce="j1c3b0b01cf832da2c5ac51bb59a05b40",
    
```

opaque="", uri="sip:+44-1234@ss1.atlanta.com;user=phone",  
response="a451358d46b55512863efe1dcca2f42"  
Content-Type: application/sdp

Content-Length: 147

```
v=0
o=UserA 2890844526 2890844526 IN IP4 client.atlanta.com
s=-
c=IN IP4 192.168.100.101
t=0 0
m=audio 49172 RTP/AVP 0
a=rtpmap:0 PCMU/8000
```

F2 100 Trying Proxy 1 -> A

```
SIP/2.0 100 Trying
Via: SIP/2.0/UDP client.atlanta.com:5060;branch=z9hG4bK74bf9
;received=192.168.100.101
From: BigGuy <sip:+13145551111@ss1.atlanta.com;user=phone>
;tag=9fxced76s1
To: LittleGuy <sip:+44-1234@ss1.atlanta.com;user=phone>
Call-ID: 2xTb9vxSit55XU7p8@atlanta.com
CSeq: 1 INVITE
Content-Length: 0
```

```
/* Proxy 1 uses a Location Service function to determine where B is
located. Based upon location analysis the call is forwarded to NGW1.
Client for A prepares to receive data on port 49172 from the network.
*/
```

F3 INVITE Proxy 1 -> NGW 1

```
INVITE sip:+44-1234@ngw1.atlanta.com;user=phone SIP/2.0
Via: SIP/2.0/UDP ss1.atlanta.com:5060;branch=z9hG4bK2d4790.1
Via: SIP/2.0/UDP client.atlanta.com:5060;branch=z9hG4bK74bf9
;received=192.168.100.101
Max-Forwards: 69
Record-Route: <sip:ss1.atlanta.com;lr>
From: BigGuy <sip:+13145551111@ss1.atlanta.com;user=phone>
;tag=9fxced76s1
To: LittleGuy <sip:+44-1234@ss1.atlanta.com;user=phone>
Call-ID: 2xTb9vxSit55XU7p8@atlanta.com
CSeq: 1 INVITE
Contact: <sip:UserA@192.168.100.101>
Content-Type: application/sdp
Content-Length: 147
```

```
v=0
o=UserA 2890844526 2890844526 IN IP4 client.atlanta.com
s=-
c=IN IP4 192.168.100.101
```

t=0 0

m=audio 49172 RTP/AVP 0

Johnston, et al.

Informational

[Page 124]



a=rtpmap:0 PCMU/8000

F4 100 Trying NGW 1 -> Proxy 1

SIP/2.0 100 Trying

Via: SIP/2.0/UDP ss1.atlanta.com:5060;branch=z9hG4bK2d4790.1  
;received=192.168.255.111

Via: SIP/2.0/UDP client.atlanta.com:5060;branch=z9hG4bK74bf9  
;received=192.168.100.101

From: BigGuy <sip:+13145551111@ss1.atlanta.com;user=phone>  
;tag=9fxced76s1

To: LittleGuy <sip:+44-1234@ss1.atlanta.com;user=phone>

Call-ID: 2xTb9vxSit55XU7p8@atlanta.com

CSeq: 1 INVITE

Content-Length: 0

F5 IAM NGW 1 -> User B

IAM

CdPN=44-1234,NPI=E.164,NOA=International

CgPN=314-555-1111,NPI=E.164,NOA=National

F6 REL User B -> NGW 1

REL

CauseValue=1 Unallocated number

F7 RLC NGW 1 -> User B

RLC

/\* Network Gateway maps CauseValue=1 to the SIP message 404 Not  
Found \*/

F8 404 Not Found NGW 1 -> Proxy 1

SIP/2.0 404 Not Found

Via: SIP/2.0/UDP ss1.atlanta.com:5060;branch=z9hG4bK2d4790.1  
;received=192.168.255.111

Via: SIP/2.0/UDP client.atlanta.com:5060;branch=z9hG4bK74bf9  
;received=192.168.100.101

From: BigGuy <sip:+13145551111@ss1.atlanta.com;user=phone>  
;tag=9fxced76s1

To: LittleGuy <sip:+44-1234@ss1.atlanta.com;user=phone>;tag=314159

Call-ID: 2xTb9vxSit55XU7p8@atlanta.com

CSeq: 1 INVITE

Error-Info: <sip:not-found-ann@ann.atlanta.com>

Johnston, et al.

Informational

[Page 125]

Content-Length: 0

F9 ACK Proxy 1 -> NGW 1

ACK sip:+44-1234@ngw1.atlanta.com;user=phone SIP/2.0  
Max-Forwards: 70  
Via: SIP/2.0/UDP ss1.atlanta.com:5060;branch=z9hG4bK2d4790.1  
From: BigGuy <sip:+13145551111@ss1.atlanta.com;user=phone>  
;tag=9fxced76sl  
To: LittleGuy <sip:+44-1234@ss1.atlanta.com;user=phone>;tag=314159  
Call-ID: 2xTb9vxSit55XU7p8@atlanta.com  
CSeq: 1 ACK  
Content-Length: 0

F10 404 Not Found Proxy 1 -> User A

SIP/2.0 404 Not Found  
Via: SIP/2.0/UDP client.atlanta.com:5060;branch=z9hG4bK74bf9  
;received=192.168.100.101  
From: BigGuy <sip:+13145551111@ss1.atlanta.com;user=phone>  
;tag=9fxced76sl  
To: LittleGuy <sip:+44-1234@ss1.atlanta.com;user=phone>;tag=314159  
Call-ID: 2xTb9vxSit55XU7p8@atlanta.com  
CSeq: 1 INVITE  
Error-Info: <sip:not-found-ann@ann.atlanta.com>  
Content-Length: 0

F11 ACK User A -> Proxy 1

ACK sip:+44-1234@ss1.atlanta.com;user=phone SIP/2.0  
Via: SIP/2.0/UDP client.atlanta.com:5060;branch=z9hG4bK74bf9  
Max-Forwards: 70  
From: BigGuy <sip:+13145551111@ss1.atlanta.com;user=phone>  
;tag=9fxced76sl  
To: LittleGuy <sip:+44-1234@ss1.atlanta.com;user=phone>;tag=314159  
Call-ID: 2xTb9vxSit55XU7p8@atlanta.com  
CSeq: 1 ACK  
Content-Length: 0



**4.2.3 Unsuccessful SIP to PSTN: ANM Timeout**

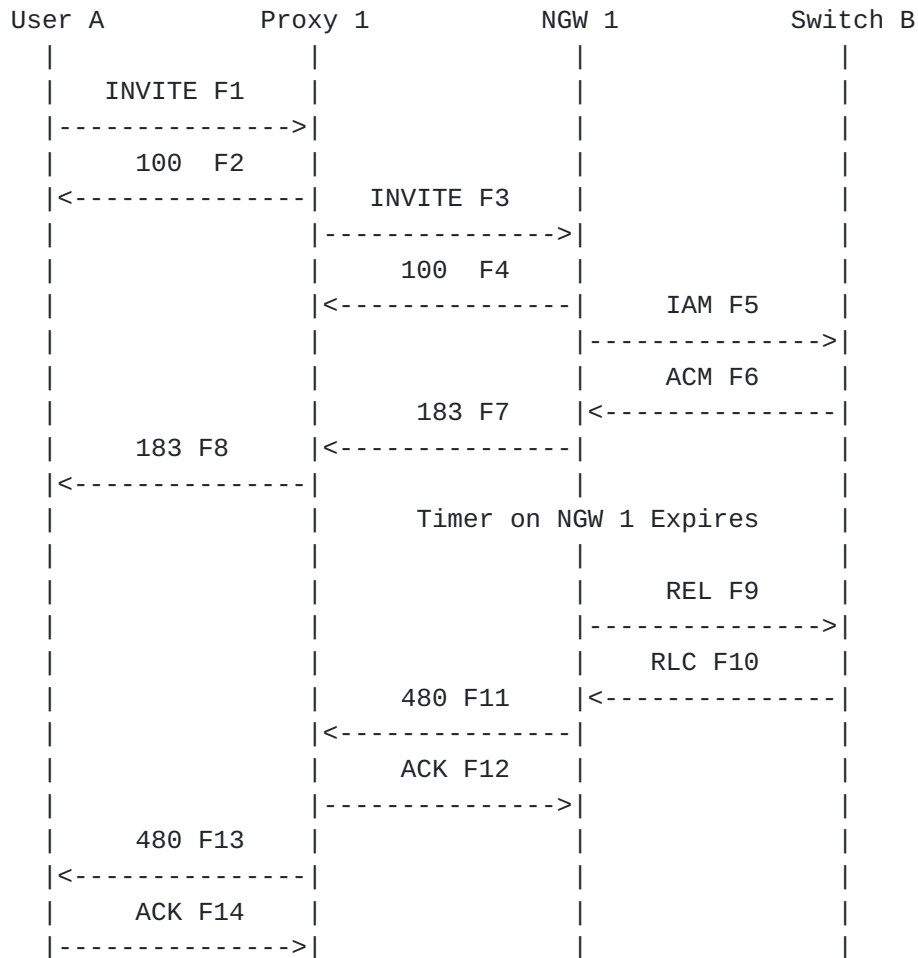

User A calls User B in the PSTN through a proxy server Proxy 1 and Network Gateway NGW 1. The call is released by the Gateway after a timer expires due to no Answer Message (ANM) being received. The Gateway sends an ISUP Release REL message to the PSTN and a 480 Temporarily Unavailable response to User A in the SIP network.

Message Details

F1 INVITE A -> Proxy 1

```

INVITE sip:+19725552222@ss1.atlanta.com;user=phone SIP/2.0
Via: SIP/2.0/UDP client.atlanta.com:5060;branch=z9hG4bK74bf9
Max-Forwards: 70
From: BigGuy <sip:+13145551111@ss1.atlanta.com;user=phone>
;tag=9fxced76s1
To: LittleGuy <sip:+19725552222@ss1.atlanta.com;user=phone>
Call-ID: 2xTb9vxSit55XU7p8@atlanta.com
    
```

CSeq: 1 INVITE  
Contact: <sip:UserA@192.168.100.101>  
Proxy-Authorization: Digest username="UserA",

Johnston, et al.

Informational

[Page 127]

```
realm="atlanta.com", nonce="da2c5ac51bb59a05j1c3b0b01cf832b40",
opaque="", uri="sip:+19725552222@ss1.atlanta.com;user=phone",
response="579cb9db184cdc25bf816f37cbc03c7d"
Content-Type: application/sdp
Content-Length: 147
```

```
v=0
o=UserA 2890844526 2890844526 IN IP4 client.atlanta.com
s=-
c=IN IP4 192.168.100.101
t=0 0
m=audio 49172 RTP/AVP 0
a=rtpmap:0 PCMU/8000
```

```
/* Proxy 1 uses a Location Service function to determine where B is
located. Based upon location analysis the call is forwarded to NGW
1. Client for A prepares to receive data on port 49172 from the
network.*/
```

F2 100 Trying Proxy 1 -> A

```
SIP/2.0 100 Trying
Via: SIP/2.0/UDP client.atlanta.com:5060;branch=z9hG4bK74bf9
;received=192.168.100.101
From: BigGuy <sip:+13145551111@ss1.atlanta.com;user=phone>
;tag=9fxced76s1
To: LittleGuy <sip:+19725552222@ss1.atlanta.com;user=phone>
Call-ID: 2xTb9vxSit55XU7p8@atlanta.com
CSeq: 1 INVITE
Content-Length: 0
```

F3 INVITE Proxy 1 -> NGW 1

```
INVITE sip:+19725552222@ngw1.atlanta.com;user=phone SIP/2.0
Via: SIP/2.0/UDP ss1.atlanta.com:5060;branch=z9hG4bK2d4790.1
Via: SIP/2.0/UDP client.atlanta.com:5060;branch=z9hG4bK74bf9
;received=192.168.100.101
Max-Forwards: 69
Record-Route: <sip:ss1.atlanta.com;lr>
From: BigGuy <sip:+13145551111@ss1.atlanta.com;user=phone>
;tag=9fxced76s1
To: LittleGuy <sip:+19725552222@ss1.atlanta.com;user=phone>
Call-ID: 2xTb9vxSit55XU7p8@atlanta.com
CSeq: 1 INVITE
Contact: <sip:UserA@192.168.100.101>
Content-Type: application/sdp
Content-Length: 147
```

v=0

o=UserA 2890844526 2890844526 IN IP4 client.atlanta.com

Johnston, et al.

Informational

[Page 128]



S=-  
c=IN IP4 192.168.100.101  
t=0 0  
m=audio 49172 RTP/AVP 0  
a=rtpmap:0 PCMU/8000

F4 100 Trying NGW 1 -> Proxy 1

SIP/2.0 100 Trying  
Via: SIP/2.0/UDP ss1.atlanta.com:5060;branch=z9hG4bK2d4790.1  
;received=192.168.255.111  
Via: SIP/2.0/UDP client.atlanta.com:5060;branch=z9hG4bK74bf9  
;received=192.168.100.101  
From: BigGuy <sip:+13145551111@ss1.atlanta.com;user=phone>  
;tag=9fxced76sl  
To: LittleGuy <sip:+19725552222@ss1.atlanta.com;user=phone>  
Call-ID: 2xTb9vxSit55XU7p8@atlanta.com  
CSeq: 1 INVITE  
Content-Length: 0

F5 IAM NGW 1 -> User B

IAM  
CdPN=972-555-2222,NPI=E.164,NOA=National  
CgPN=314-555-1111,NPI=E.164,NOA=National

F6 ACM User B -> NGW 1

ACM

F7 183 Session Progress NGW 1 -> Proxy 1

SIP/2.0 183 Session Progress  
Via: SIP/2.0/UDP ss1.atlanta.com:5060;branch=z9hG4bK2d4790.1  
;received=192.168.255.111  
Via: SIP/2.0/UDP client.atlanta.com:5060;branch=z9hG4bK74bf9  
;received=192.168.100.101  
Record-Route: <sip:ss1.atlanta.com;lr>  
From: BigGuy <sip:+13145551111@ss1.atlanta.com;user=phone>  
;tag=9fxced76sl  
To: LittleGuy <sip:+19725552222@ss1.atlanta.com;user=phone>  
;tag=314159  
Call-ID: 2xTb9vxSit55XU7p8@atlanta.com  
CSeq: 1 INVITE  
Contact: <sip:+19725552222@ngw1.atlanta.com;user=phone>  
Content-Type: application/sdp

Content-Length: 141

Johnston, et al.

Informational

[Page 129]

```
v=0
o=GW 2890844527 2890844527 IN IP4 ngw1.atlanta.com
s=-
c=IN IP4 192.168.255.101
t=0 0
m=audio 3456 RTP/AVP 0
a=rtpmap:0 PCMU/8000
```

F8 183 Session Progress Proxy 1 -> User A

```
SIP/2.0 183 Session Progress
Via: SIP/2.0/UDP client.atlanta.com:5060;branch=z9hG4bK74bf9
;received=192.168.100.101
Record-Route: <sip:ss1.atlanta.com;lr>
From: BigGuy <sip:+13145551111@ss1.atlanta.com;user=phone>
;tag=9fxced76s1
To: LittleGuy <sip:+19725552222@ss1.atlanta.com;user=phone>
;tag=314159
Call-ID: 2xTb9vxSit55XU7p8@atlanta.com
CSeq: 1 INVITE
Contact: <sip:+19725552222@ngw1.atlanta.com;user=phone>
Content-Type: application/sdp
Content-Length: 141
```

```
v=0
o=GW 2890844527 2890844527 IN IP4 ngw1.atlanta.com
s=-
c=IN IP4 192.168.255.201
t=0 0
m=audio 3456 RTP/AVP 0
a=rtpmap:0 PCMU/8000
```

/\* After NGW 1's timer expires, Network Gateway sends REL to ISUP network and 480 to SIP network \*/

F9 REL NGW 1 -> User B

```
REL
CauseCode=18 No user responding
```

F10 RLC User B -> NGW 1

```
RLC
```

F11 480 Temporarily Unavailable NGW 1 -> Proxy 1

SIP/2.0 480 Temporarily Unavailable

Via: SIP/2.0/UDP ss1.atlanta.com:5060;branch=z9hG4bK2d4790.1

Johnston, et al.

Informational

[Page 130]

;received=192.168.255.111  
Via: SIP/2.0/UDP client.atlanta.com:5060;branch=z9hG4bK74bf9  
;received=192.168.100.101  
From: BigGuy <sip:+13145551111@ss1.atlanta.com;user=phone>  
;tag=9fxced76sl  
To: LittleGuy <sip:+19725552222@ss1.atlanta.com;user=phone>  
;tag=314159  
Call-ID: 2xTb9vxSit55XU7p8@atlanta.com  
CSeq: 1 INVITE  
Error-Info: <sip:temp-unavail-ann@ann.atlanta.com>  
Content-Length: 0

F12 ACK Proxy 1 -> NGW 1

ACK sip:+19725552222@ngw1.atlanta.com;user=phone SIP/2.0  
Via: SIP/2.0/UDP ss1.atlanta.com:5060;branch=z9hG4bK2d4790.1  
Max-Forwards: 70  
From: BigGuy <sip:+13145551111@ss1.atlanta.com;user=phone>  
;tag=9fxced76sl  
To: LittleGuy <sip:+19725552222@ss1.atlanta.com;user=phone>  
;tag=314159  
Call-ID: 2xTb9vxSit55XU7p8@atlanta.com  
CSeq: 1 ACK  
Content-Length: 0

F13 480 Temporarily Unavailable F13 Proxy 1 -> User A

SIP/2.0 480 Temporarily Unavailable  
Via: SIP/2.0/UDP client.atlanta.com:5060;branch=z9hG4bK74bf9  
;received=192.168.100.101  
From: BigGuy <sip:+13145551111@ss1.atlanta.com;user=phone>  
;tag=9fxced76sl  
To: LittleGuy <sip:+19725552222@ss1.atlanta.com;user=phone>  
;tag=314159  
Call-ID: 2xTb9vxSit55XU7p8@atlanta.com  
CSeq: 1 INVITE  
Error-Info: <sip:temp-unavail-ann@ann.atlanta.com>  
Content-Length: 0

F14 ACK User A -> Proxy 1

ACK sip:+19725552222@ss1.atlanta.com;user=phone SIP/2.0  
Max-Forwards: 70  
Via: SIP/2.0/UDP client.atlanta.com:5060;branch=z9hG4bK74bf9  
From: BigGuy <sip:+13145551111@ss1.atlanta.com;user=phone>  
;tag=9fxced76sl  
To: LittleGuy <sip:+19725552222@ss1.atlanta.com;user=phone>

;tag=314159  
Call-ID: 2xTb9vXSit55XU7p8@atlanta.com

Johnston, et al.

Informational

[Page 131]

Internet Draft

SIP Call Flow Examples

July 2002

CSeq: 1 ACK  
Content-Length: 0





## **5 Gateway to SIP Dialing**

### **5.1 Success Scenarios**

In these scenarios, User A is placing calls from the PSTN to User B in a SIP network. User A's telephone switch signals to a Network Gateway (NGW 1) using ANSI ISUP.

Since the called SIP User Agent does not send in-band signaling information, no early media path needs to be established on the IP side. As a result, the 183 Session Progress response is not used. However, NGW 1 will establish a one way speech path prior to call completion, and generate ringing for the PSTN caller. Any tones or recordings are generated by NGW 1 and played in this speech path. When the call completes successfully, NGW 1 bridges the PSTN speech path with the IP media path.

To reduce the number of messages, only a single proxy server is shown in these flows, which means that the atlanta.com proxy server has access to the biloxi.com location service.



**5.1.1 Successful PSTN to SIP call**

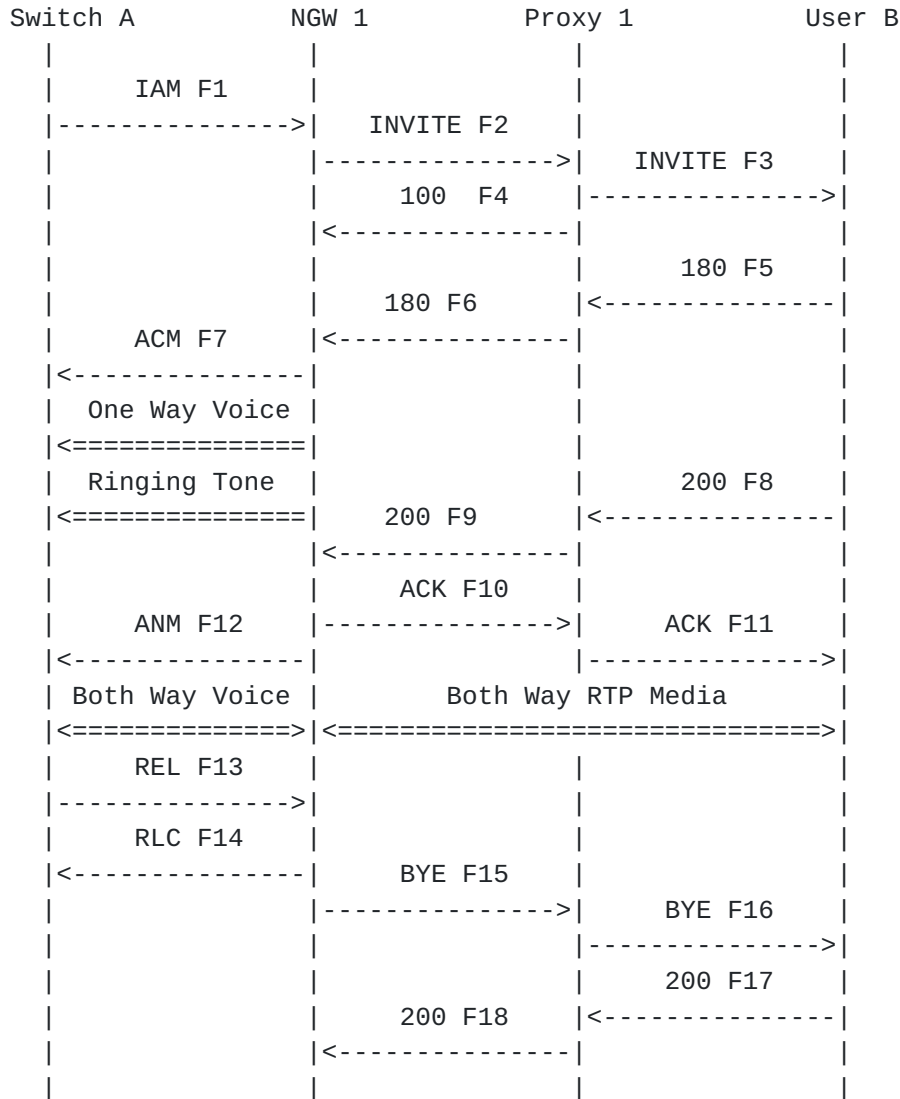

In this scenario, User A from the PSTN calls User B through a Network Gateway NGW1 and Proxy Server Proxy 1. When User B answers the call the media path is setup end-to-end. The call terminates when User A hangs up the call, with User A's telephone switch sending an ISUP RELease message which is mapped to a BYE by NGW 1.

Message Details

F1 IAM User A -> NGW 1

IAM

CgPN=314-555-1111,NPI=E.164,NOA=National

CdPN=972-555-2222,NPI=E.164,NOA=National

F2 INVITE A -> Proxy 1

Johnston, et al.

Informational

[Page 134]

```
INVITE sip:+19725552222@ss1.atlanta.com;user=phone SIP/2.0
Via: SIP/2.0/UDP ngw1.atlanta.com:5060;branch=z9hG4bKlueha2
Max-Forwards: 70
From: <sip:+13145551111@ngw1.atlanta.com;user=phone>;tag=7643kals
To: <sip:+19725552222@ss1.atlanta.com;user=phone>
Call-ID: 4Fde34wkd11wsGFDS3@ngw1.atlanta.com
CSeq: 1 INVITE
Contact: <sip:+13145551111@ngw1.atlanta.com;user=phone>
Content-Type: application/sdp
Content-Length: 141
```

```
v=0
o=GW 2890844527 2890844527 IN IP4 ngw1.atlanta.com
s=-
c=IN IP4 192.168.255.101
t=0 0
m=audio 3456 RTP/AVP 0
a=rtpmap:0 PCMU/8000
```

```
/* Proxy 1 uses a Location Service function to determine where B is
located. Based upon location analysis the call is forwarded to NGW
1. NGW 1 prepares to receive data on port 3456 from User A.*/
```

```
F3 INVITE Proxy 1 -> User B
```

```
INVITE sip:UserB@192.168.200.201 SIP/2.0
Via: SIP/2.0/UDP ss1.atlanta.com:5060;branch=z9hG4bK2d4790.1
Via: SIP/2.0/UDP ngw1.atlanta.com:5060;branch=z9hG4bKlueha2
;received=192.168.255.101
Max-Forwards: 69
Record-Route: <sip:ss1.atlanta.com;lr>
From: <sip:+13145551111@ngw1.atlanta.com;user=phone>;tag=7643kals
To: <sip:+19725552222@ss1.atlanta.com;user=phone>
Call-ID: 4Fde34wkd11wsGFDS3@ngw1.atlanta.com
CSeq: 1 INVITE
Contact: <sip:+13145551111@ngw1.atlanta.com;user=phone>
Content-Type: application/sdp
Content-Length: 141
```

```
v=0
o=GW 2890844527 2890844527 IN IP4 ngw1.atlanta.com
s=-
c=IN IP4 192.168.255.101
t=0 0
m=audio 3456 RTP/AVP 0
a=rtpmap:0 PCMU/8000
```

F4 100 Trying User B -> Proxy 1

SIP/2.0 100 Trying

Johnston, et al.

Informational

[Page 135]

Via: SIP/2.0/UDP ss1.atlanta.com:5060;branch=z9hG4bK2d4790.1  
;received=192.168.255.111  
Via: SIP/2.0/UDP ngw1.atlanta.com:5060;branch=z9hG4bKlueha2  
;received=192.168.255.101  
From: <sip:+13145551111@ngw1.atlanta.com;user=phone>;tag=7643kals  
To: <sip:+19725552222@ss1.atlanta.com;user=phone>  
Call-ID: 4Fde34wkd11wsGFds3@ngw1.atlanta.com  
CSeq: 1 INVITE  
Content-Length: 0

F5 180 Ringing User B -> Proxy 1

SIP/2.0 180 Ringing  
Via: SIP/2.0/UDP ss1.atlanta.com:5060;branch=z9hG4bK2d4790.1  
;received=192.168.255.111  
Via: SIP/2.0/UDP ngw1.atlanta.com:5060;branch=z9hG4bKlueha2  
;received=192.168.255.101  
Record-Route: <sip:ss1.atlanta.com;lr>  
From: <sip:+13145551111@ngw1.atlanta.com;user=phone>;tag=7643kals  
To: <sip:+19725552222@ss1.atlanta.com;user=phone>;tag=314159  
Call-ID: 4Fde34wkd11wsGFds3@ngw1.atlanta.com  
CSeq: 1 INVITE  
Contact: <sip:UserB@192.168.200.201>  
Content-Length: 0

F6 180 Ringing Proxy 1 -> NGW 1

SIP/2.0 180 Ringing  
Via: SIP/2.0/UDP ngw1.atlanta.com:5060;branch=z9hG4bKlueha2  
;received=192.168.255.101  
Record-Route: <sip:ss1.atlanta.com;lr>  
From: <sip:+13145551111@ngw1.atlanta.com;user=phone>;tag=7643kals  
To: <sip:+19725552222@ss1.atlanta.com;user=phone>;tag=314159  
Call-ID: 4Fde34wkd11wsGFds3@ngw1.atlanta.com  
CSeq: 1 INVITE  
Contact: <sip:UserB@192.168.200.201>  
Content-Length: 0

F7 ACM NGW 1 -> User A

ACM

F8 200 OK User B -> Proxy 1

SIP/2.0 200 OK  
Via: SIP/2.0/UDP ss1.atlanta.com:5060;branch=z9hG4bK2d4790.1

;received=192.168.255.111  
Via: SIP/2.0/UDP ngw1.atlanta.com:5060;branch=z9hG4bKlueha2

Johnston, et al.

Informational

[Page 136]



```
;received=192.168.255.101
Record-Route: <sip:ss1.atlanta.com;lr>
From: <sip:+13145551111@ngw1.atlanta.com;user=phone>;tag=7643kals
To: <sip:+19725552222@ss1.atlanta.com;user=phone>;tag=314159
Call-ID: 4Fde34wkd11wsGFDS3@ngw1.atlanta.com
Contact: <sip:UserB@192.168.200.201>
CSeq: 1 INVITE
Content-Type: application/sdp
Content-Length: 145
```

```
v=0
o=UserB 2890844527 2890844527 IN IP4 client.biloxi.com
s=-
c=IN IP4 192.168.200.201
t=0 0
m=audio 3456 RTP/AVP 0
a=rtpmap:0 PCMU/8000
```

F9 200 OK Proxy 1 -> NGW 1

```
SIP/2.0 200 OK
Via: SIP/2.0/UDP ngw1.atlanta.com:5060;branch=z9hG4bKlueha2
;received=192.168.255.101
Record-Route: <sip:ss1.atlanta.com;lr>
From: <sip:+13145551111@ngw1.atlanta.com;user=phone>;tag=7643kals
To: <sip:+19725552222@ss1.atlanta.com;user=phone>;tag=314159
Call-ID: 4Fde34wkd11wsGFDS3@ngw1.atlanta.com
CSeq: 1 INVITE
Contact: <sip:UserB@192.168.200.201>
Content-Type: application/sdp
Content-Length: 145
```

```
v=0
o=UserB 2890844527 2890844527 IN IP4 client.biloxi.com
s=-
c=IN IP4 192.168.200.201
t=0 0
m=audio 3456 RTP/AVP 0
a=rtpmap:0 PCMU/8000
```

F10 ACK NGW 1 -> Proxy 1

```
ACK sip:UserB@192.168.200.201 SIP/2.0
Via: SIP/2.0/UDP ngw1.atlanta.com:5060;branch=z9hG4bKlueha2
Max-Forwards: 70
Route: <sip:ss1.atlanta.com;lr>
From: <sip:+13145551111@ngw1.atlanta.com;user=phone>;tag=7643kals
```

To: <sip:+19725552222@ss1.atlanta.com;user=phone>;tag=314159  
Call-ID: 4Fde34wkd11wsGFDS3@ngw1.atlanta.com  
CSeq: 1 ACK

Johnston, et al.

Informational

[Page 137]

Content-Length: 0

F11 ACK Proxy 1 -> User B

ACK sip:UserB@192.168.200.201 SIP/2.0  
Via: SIP/2.0/UDP ss1.atlanta.com:5060;branch=z9hG4bK2d4790.1  
Via: SIP/2.0/UDP ngw1.atlanta.com:5060;branch=z9hG4bKlueha2  
;received=192.168.255.101  
Max-Forwards: 69  
From: <sip:+13145551111@ngw1.atlanta.com;user=phone>;tag=7643kals  
To: <sip:+19725552222@ss1.atlanta.com;user=phone>;tag=314159  
Call-ID: 4Fde34wkd11wsGFDS3@ngw1.atlanta.com  
CSeq: 1 ACK  
Content-Length: 0

F12 ANM User B -> NGW 1

ANM

/\* RTP streams are established between A and B (via the GW) \*/

/\* User A Hangs Up with User B. \*/

F13 REL User A -> NGW 1

REL  
CauseCode=16 Normal

F14 RLC NGW 1 -> User A

RLC

F15 BYE NGW 1-> Proxy 1

BYE sip:UserB@192.168.200.201 SIP/2.0  
Via: SIP/2.0/UDP ngw1.atlanta.com:5060;branch=z9hG4bKlueha2  
Max-Forwards: 70  
Route: <sip:ss1.atlanta.com;lr>  
From: <sip:+13145551111@ngw1.atlanta.com;user=phone>;tag=7643kals  
To: <sip:+19725552222@ss1.atlanta.com;user=phone>;tag=314159  
Call-ID: 4Fde34wkd11wsGFDS3@ngw1.atlanta.com  
CSeq: 2 BYE  
Content-Length: 0

F16 BYE Proxy 1 -> User B

Johnston, et al.

Informational

[Page 138]

BYE sip:UserB@192.168.200.201 SIP/2.0  
Via: SIP/2.0/UDP ss1.atlanta.com:5060;branch=z9hG4bK2d4790.1  
Via: SIP/2.0/UDP ngw1.atlanta.com:5060;branch=z9hG4bKlueha2  
;received=192.168.255.101  
Max-Forwards: 69  
From: <sip:+13145551111@ngw1.atlanta.com;user=phone>;tag=7643kals  
To: <sip:+19725552222@ss1.atlanta.com;user=phone>;tag=314159  
Call-ID: 4Fde34wkd11wsGFDS3@ngw1.atlanta.com  
CSeq: 2 BYE  
Content-Length: 0

F17 200 OK User B -> Proxy 1

SIP/2.0 200 OK  
Via: SIP/2.0/UDP ss1.atlanta.com:5060;branch=z9hG4bK2d4790.1  
;received=192.168.255.111  
Via: SIP/2.0/UDP ngw1.atlanta.com:5060;branch=z9hG4bKlueha2  
;received=192.168.255.101  
From: <sip:+13145551111@ngw1.atlanta.com;user=phone>;tag=7643kals  
To: <sip:+19725552222@ss1.atlanta.com;user=phone>;tag=314159  
Call-ID: 4Fde34wkd11wsGFDS3@ngw1.atlanta.com  
CSeq: 2 BYE  
Content-Length: 0

F18 200 OK Proxy 1 -> NGW 1

SIP/2.0 200 OK  
Via: SIP/2.0/UDP ngw1.atlanta.com:5060;branch=z9hG4bKlueha2  
;received=192.168.255.101  
From: <sip:+13145551111@ngw1.atlanta.com;user=phone>;tag=7643kals  
To: <sip:+19725552222@ss1.atlanta.com;user=phone>;tag=314159  
Call-ID: 4Fde34wkd11wsGFDS3@ngw1.atlanta.com  
CSeq: 2 BYE  
Content-Length: 0



5.1.2 Successful PSTN to SIP call, Fast Answer

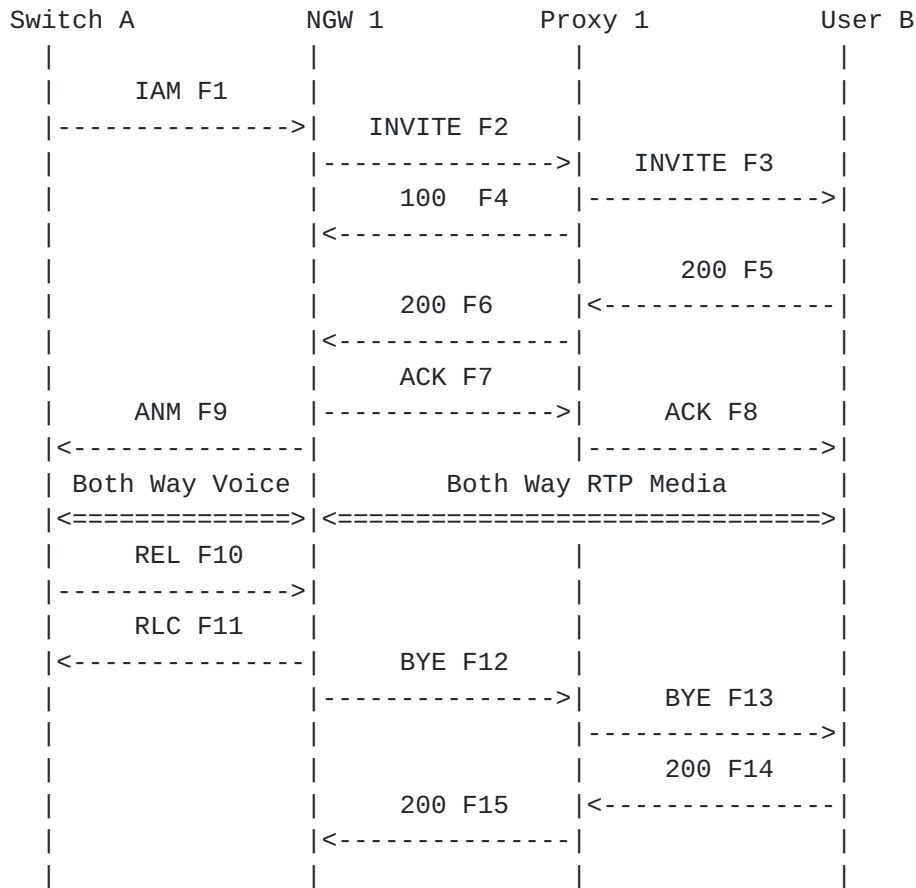

This "fast answer" scenario is similar to 5.1.1 except that User B immediately accepts the call, sending a 200 OK (F5) without sending a 180 Ringing response. The Gateway then sends an Answer Message (ANM) without sending an Address Complete Message (ACM). Note that for ETSI and some other ISUP variants, a CONnect message (CON) would be sent instead of the ANM.

Message Details

F1 IAM User A -> NGW 1

IAM  
 CgPN=314-555-1111,NPI=E.164,NOA=National  
 CdPN=972-555-2222,NPI=E.164,NOA=National

F2 INVITE NGW 1 -> Proxy 1

INVITE sip:+19725552222@ngw1.atlanta.com;user=phone SIP/2.0  
 Via: SIP/2.0/UDP ngw1.atlanta.com:5060;branch=z9hG4bKlueha2  
 Max-Forwards: 70

From: <sip:+13145551111@ngw1.atlanta.com;user=phone>;tag=7643kals  
To: <sip:+19725552222@ss1.atlanta.com;user=phone>

Johnston, et al.

Informational

[Page 140]



Call-ID: 4Fde34wkd11wsGFds3@ngw1.atlanta.com  
CSeq: 1 INVITE  
Contact: <sip:+13145551111@ngw1.atlanta.com;user=phone>  
Content-Type: application/sdp  
Content-Length: 141

v=0  
o=GW 2890844527 2890844527 IN IP4 ngw1.atlanta.com  
s=-  
c=IN IP4 192.168.255.101  
t=0 0  
m=audio 3456 RTP/AVP 0  
a=rtpmap:0 PCMU/8000

/\* Proxy 1 uses a Location Service function to determine where B is located. Based upon location analysis the call is forwarded to User B. User B prepares to receive data on port 3456 from User A.\*/

F3 INVITE Proxy 1 -> User B

INVITE UserB@biloxi.com SIP/2.0  
Via: SIP/2.0/UDP ss1.atlanta.com:5060;branch=z9hG4bK2d4790.1  
Via: SIP/2.0/UDP ngw1.atlanta.com:5060;branch=z9hG4bKlueha2  
;received=192.168.255.101  
Max-Forwards: 69  
Record-Route: <sip:ss1.atlanta.com;lr>  
From: <sip:+13145551111@ngw1.atlanta.com;user=phone>;tag=7643kals  
To: <sip:+19725552222@ss1.atlanta.com;user=phone>  
Call-ID: 4Fde34wkd11wsGFds3@ngw1.atlanta.com  
CSeq: 1 INVITE  
Contact: <sip:+13145551111@ngw1.atlanta.com;user=phone>  
Content-Type: application/sdp  
Content-Length: 141

v=0  
o=GW 2890844527 2890844527 IN IP4 ngw1.atlanta.com  
s=-  
c=IN IP4 192.168.255.101  
t=0 0  
m=audio 3456 RTP/AVP 0  
a=rtpmap:0 PCMU/8000

F4 100 Trying Proxy 1 -> NGW 1

SIP/2.0 100 Trying  
Via: SIP/2.0/UDP ngw1.atlanta.com:5060;branch=z9hG4bKlueha2  
;received=192.168.255.201  
From: <sip:+13145551111@ngw1.atlanta.com;user=phone>;tag=7643kals

To: <sip:+19725552222@ss1.atlanta.com;user=phone>  
Call-ID: 4Fde34wkd11wsGFDS3@ngw1.atlanta.com

Johnston, et al.

Informational

[Page 141]

CSeq: 1 INVITE  
Content-Length: 0

F5 200 OK User B -> Proxy 1

SIP/2.0 200 OK  
Via: SIP/2.0/UDP ss1.atlanta.com:5060;branch=z9hG4bK2d4790.1  
;received=192.168.255.111  
Via: SIP/2.0/UDP ngw1.atlanta.com:5060;branch=z9hG4bKlueha2  
;received=192.168.255.101  
Record-Route: <sip:ss1.atlanta.com;lr>  
From: <sip:+13145551111@ngw1.atlanta.com;user=phone>;tag=7643kals  
To: <sip:+19725552222@ss1.atlanta.com;user=phone>;tag=314159  
Call-ID: 4Fde34wkd11wsGFDS3@ngw1.atlanta.com  
CSeq: 1 INVITE  
Contact: <sip:UserB@192.168.200.201>  
Content-Type: application/sdp  
Content-Length: 145

v=0  
o=UserB 2890844527 2890844527 IN IP4 client.biloxi.com  
s=-  
c=IN IP4 192.168.200.201  
t=0 0  
m=audio 3456 RTP/AVP 0  
a=rtpmap:0 PCMU/8000

F6 200 OK Proxy 1 -> NGW 1

SIP/2.0 200 OK  
Via: SIP/2.0/UDP ngw1.atlanta.com:5060;branch=z9hG4bKlueha2  
;received=192.168.255.101  
Record-Route: <sip:ss1.atlanta.com;lr>  
From: <sip:+13145551111@ngw1.atlanta.com;user=phone>;tag=7643kals  
To: <sip:+19725552222@ss1.atlanta.com;user=phone>;tag=314159  
Call-ID: 4Fde34wkd11wsGFDS3@ngw1.atlanta.com  
CSeq: 1 INVITE  
Contact: <sip:UserB@192.168.200.201>  
Content-Type: application/sdp  
Content-Length: 145

v=0  
o=GW 2890844527 2890844527 IN IP4 ngw1.atlanta.com  
s=-  
c=IN IP4 192.168.200.201  
t=0 0  
m=audio 3456 RTP/AVP 0

a=rtpmap:0 PCMU/8000

Johnston, et al.

Informational

[Page 142]

F7 ACK NGW 1 -> Proxy 1

ACK UserB@192.168.200.201 SIP/2.0  
Via: SIP/2.0/UDP ngw1.atlanta.com:5060;branch=z9hG4bKlueha2  
Max-Forwards: 70  
Route: <sip:ss1.atlanta.com;lr>  
From: <sip:+13145551111@ngw1.atlanta.com;user=phone>;tag=7643kals  
To: <sip:+19725552222@ss1.atlanta.com;user=phone>;tag=314159  
Call-ID: 4Fde34wkd11wsGFds3@ngw1.atlanta.com  
CSeq: 1 ACK  
Content-Length: 0

F8 ACK Proxy 1 -> User B

ACK UserB@192.168.200.201 SIP/2.0  
Via: SIP/2.0/UDP ss1.atlanta.com:5060;branch=z9hG4bK2d4790.1  
Via: SIP/2.0/UDP ngw1.atlanta.com:5060;branch=z9hG4bKlueha2  
;received=130.131.132.14  
Max-Forwards: 69  
From: <sip:+13145551111@ngw1.atlanta.com;user=phone>;tag=7643kals  
To: <sip:+19725552222@ss1.atlanta.com;user=phone>;tag=314159  
Call-ID: 4Fde34wkd11wsGFds3@ngw1.atlanta.com  
CSeq: 1 ACK  
Content-Length: 0

F9 ANM User B -> NGW 1

ANM

/\* RTP streams are established between A and B (via the GW) \*/

/\* User A Hangs Up with User B. \*/

F10 REL ser A -> NGW 1

REL  
CauseCode=16 Normal

F11 RLC NGW 1 -> User A

RLC

F12 BYE NGW 1 -> Proxy 1

BYE sip:UserB@192.168.200.201 SIP/2.0

Via: SIP/2.0/UDP ngw1.atlanta.com:5060;branch=z9hG4bKlueha2  
Max-Forwards: 70

Johnston, et al.

Informational

[Page 143]

Route: <sip:ss1.atlanta.com;lr>  
From: <sip:+13145551111@ngw1.atlanta.com;user=phone>;tag=7643kals  
To: <sip:+19725552222@ss1.atlanta.com;user=phone>;tag=314159  
Call-ID: 4Fde34wkd11wsGFDS3@ngw1.atlanta.com  
CSeq: 2 BYE  
Content-Length: 0

F13 BYE Proxy 1 -> User B

BYE sip:UserB@192.168.200.201 SIP/2.0  
Via: SIP/2.0/UDP ss1.atlanta.com:5060;branch=z9hG4bK2d4790.1  
Via: SIP/2.0/UDP ngw1.atlanta.com:5060;branch=z9hG4bKlueha2  
;received=192.168.255.101  
Max-Forwards: 69  
From: <sip:+13145551111@ngw1.atlanta.com;user=phone>;tag=7643kals  
To: <sip:+19725552222@ss1.atlanta.com;user=phone>;tag=314159  
Call-ID: 4Fde34wkd11wsGFDS3@ngw1.atlanta.com  
CSeq: 2 BYE  
Content-Length: 0

F14 200 OK User B -> Proxy 1

SIP/2.0 200 OK  
Via: SIP/2.0/UDP ss1.atlanta.com:5060;branch=z9hG4bK2d4790.1  
;received=192.168.255.111  
Via: SIP/2.0/UDP ngw1.atlanta.com:5060;branch=z9hG4bKlueha2  
;received=192.168.255.101  
From: <sip:+13145551111@ngw1.atlanta.com;user=phone>;tag=7643kals  
To: <sip:+19725552222@ss1.atlanta.com;user=phone>;tag=314159  
Call-ID: 4Fde34wkd11wsGFDS3@ngw1.atlanta.com  
CSeq: 2 BYE  
Content-Length: 0

F15 200 OK Proxy 1 -> NGW 1

SIP/2.0 200 OK  
Via: SIP/2.0/UDP ngw1.atlanta.com:5060;branch=z9hG4bKlueha2  
;received=192.168.255.101  
From: <sip:+13145551111@ngw1.atlanta.com;user=phone>;tag=7643kals  
To: <sip:+19725552222@ss1.atlanta.com;user=phone>;tag=314159  
Call-ID: 4Fde34wkd11wsGFDS3@ngw1.atlanta.com  
CSeq: 2 BYE  
Content-Length: 0





**5.1.1.3 Successful PBX to SIP call**

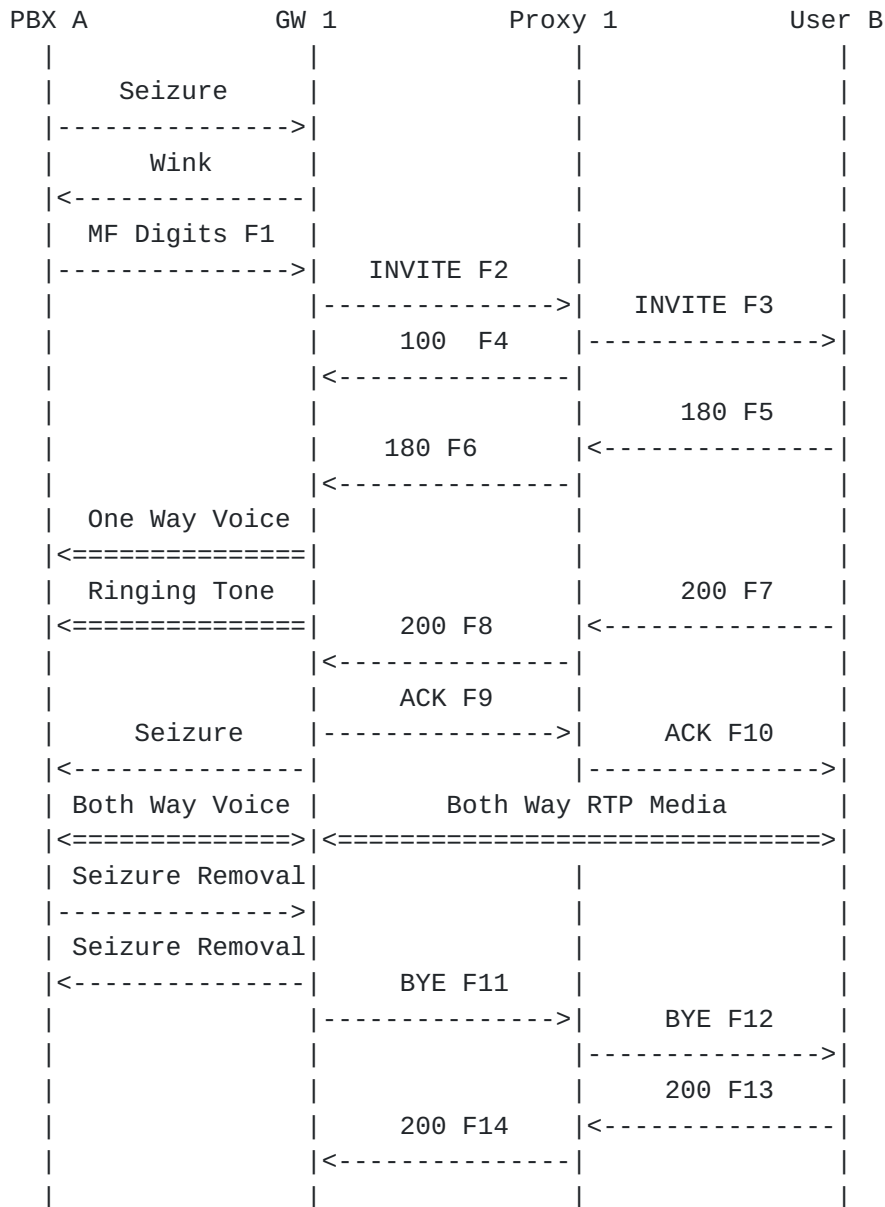

In this scenario, User A dials from PBX A to User B through GW 1 and Proxy 1. This is an example of a call that appears destined for the PSTN but instead is routed to a SIP Client.

Signaling between PBX A and GW 1 is Feature Group B (FGB) circuit associated signaling, in-band Multi-Frequency (MF) outputting. After the receipt of the 180 Ringing from User B, GW 1 generates ringing tone for User A.

User B answers the call by sending a 200 OK. The call terminates when User A hangs up, causing GW1 to send a BYE.

The Gateway can only identify the trunk group that the call came in on, it cannot identify the individual line on PBX A that is placing the call. The SIP URI used to identify the caller is

Johnston, et al.

Informational

[Page 145]

shown in these flows as sip:551313@gw1.atlanta.com.

Message Details

PBX A -> GW 1

Seizure

GW 1 -> PBX A

Wink

F1 MF Digits PBX A -> GW 1

KP 1 972 555 2222 ST

F2 INVITE GW 1 -> Proxy 1

```
INVITE sip:+19725552222@ss1.atlanta.com;user=phone SIP/2.0
Via: SIP/2.0/UDP gw1.atlanta.com:5060;branch=z9hG4bKwqwee65
Max-Forwards: 70
From: <sip:551313@gw1.atlanta.com;user=phone>;tag=jwdkallkzm
To: <sip:+19725552222@ss1.atlanta.com;user=phone>
Call-ID: 4Fde34wkd11wsGFds3@gw1.atlanta.com
CSeq: 1 INVITE
Contact: <sip:551313@gw1.atlanta.com;user=phone>
Content-Type: application/sdp
Content-Length: 141
```

```
v=0
o=GW 2890844527 2890844527 IN IP4 ngw1.atlanta.com
s=-
c=IN IP4 192.168.255.201
t=0 0
m=audio 3456 RTP/AVP 0
a=rtpmap:0 PCMU/8000
```

/\* Proxy 1 uses a Location Service function to determine where the phone number +19725552222 is located. Based upon location analysis the call is forwarded to SIP User B. \*/

F3 INVITE Proxy 1 -> User B

```
INVITE sip:UserB@192.168.200.201 SIP/2.0
Via: SIP/2.0/UDP ss1.atlanta.com:5060;branch=z9hG4bK2d4790.1
```

Via: SIP/2.0/UDP gw1.atlanta.com:5060;branch=z9hG4bKwqwee65  
;received=192.168.255.201

Johnston, et al.

Informational

[Page 146]

Max-Forwards: 69  
Record-Route: <sip:ss1.atlanta.com;lr>  
From: <sip:551313@gw1.atlanta.com;user=phone>;tag=jwdkallkzm  
To: <sip:+19725552222@ss1.atlanta.com;user=phone>  
Call-ID: 4Fde34wkd11wsGFds3@gw1.atlanta.com  
CSeq: 1 INVITE  
Contact: <sip:551313@gw1.atlanta.com;user=phone>  
Content-Type: application/sdp  
Content-Length: 141

v=0  
o=GW 2890844527 2890844527 IN IP4 gw1.atlanta.com  
s=-  
c=IN IP4 192.168.255.201  
t=0 0  
m=audio 3456 RTP/AVP 0  
a=rtpmap:0 PCMU/8000

F4 100 Trying Proxy 1 -> GW 1

SIP/2.0 100 Trying  
Via: SIP/2.0/UDP ngw1.atlanta.com:5060;branch=z9hG4bKlueha2  
;received=192.168.255.201  
From: <sip:551313@gw1.atlanta.com;user=phone>;tag=jwdkallkzm  
To: <sip:+19725552222@ss1.atlanta.com;user=phone>;tag=314159  
Call-ID: 4Fde34wkd11wsGFds3@gw1.atlanta.com  
CSeq: 1 INVITE  
Content-Length: 0

F5 180 Ringing User B -> Proxy 1

SIP/2.0 180 Ringing  
Via: SIP/2.0/UDP ss1.atlanta.com:5060;branch=z9hG4bK2d4790.1  
;received=192.168.255.111  
Via: SIP/2.0/UDP ngw1.atlanta.com:5060;branch=z9hG4bKlueha2  
;received=192.168.255.201  
Record-Route: <sip:ss1.atlanta.com;lr>  
From: <sip:551313@gw1.atlanta.com;user=phone>;tag=jwdkallkzm  
To: <sip:+19725552222@ss1.atlanta.com;user=phone>;tag=314159  
Call-ID: 4Fde34wkd11wsGFds3@gw1.atlanta.com  
CSeq: 1 INVITE  
Contact: <sip:UserB@192.168.200.201>  
Content-Length: 0

F6 180 Ringing Proxy 1 -> GW 1

SIP/2.0 180 Ringing

Via: SIP/2.0/UDP gw1.atlanta.com:5060;branch=z9hG4bKwqwee65  
;received=192.168.255.201

Johnston, et al.

Informational

[Page 147]

```
Record-Route: <sip:ss1.atlanta.com;lr>
From: <sip:551313@gw1.atlanta.com;user=phone>;tag=jwdkallkzm
To: <sip:+19725552222@ss1.atlanta.com;user=phone>;tag=314159
Call-ID: 4Fde34wkd11wsGFDS3@gw1.atlanta.com
CSeq: 1 INVITE
Contact: <sip:UserB@192.168.200.201>
Content-Length: 0
```

```
/* One way Voice path is established between GW and the PBX for
ringing. */
```

```
F7 200 OK User B -> Proxy 1
```

```
SIP/2.0 200 OK
Via: SIP/2.0/UDP ss1.atlanta.com:5060;branch=z9hG4bK2d4790.1
;received=192.168.255.111
Via: SIP/2.0/UDP gw1.atlanta.com:5060;branch=z9hG4bKwqwee65
;received=192.168.255.201
Record-Route: <sip:ss1.atlanta.com;lr>
From: <sip:551313@gw1.atlanta.com;user=phone>;tag=jwdkallkzm
To: <sip:+19725552222@ss1.atlanta.com;user=phone>;tag=314159
Call-ID: 4Fde34wkd11wsGFDS3@gw1.atlanta.com
Contact: <sip:UserB@192.168.200.201>
CSeq: 1 INVITE
Content-Type: application/sdp
Content-Length: 145
```

```
v=0
o=UserB 2890844527 2890844527 IN IP4 client.biloxi.com
s=-
c=IN IP4 192.168.200.201
t=0 0
m=audio 3456 RTP/AVP 0
a=rtpmap:0 PCMU/8000
```

```
F8 200 OK Proxy 1 -> GW 1
```

```
SIP/2.0 200 OK
Via: SIP/2.0/UDP gw1.atlanta.com:5060;branch=z9hG4bKwqwee65
;received=192.168.255.201
Record-Route: <sip:ss1.atlanta.com;lr>
From: <sip:551313@gw1.atlanta.com;user=phone>;tag=jwdkallkzm
To: <sip:+19725552222@ss1.atlanta.com;user=phone>;tag=314159
Call-ID: 4Fde34wkd11wsGFDS3@gw1.atlanta.com
CSeq: 1 INVITE
Contact: <sip:UserB@192.168.200.201>
Content-Type: application/sdp
```

Content-Length: 145

v=0

Johnston, et al.

Informational

[Page 148]



```
o=UserB 2890844527 2890844527 IN IP4 client.biloxi.com
s=-
c=IN IP4 192.168.200.201
t=0 0
m=audio 3456 RTP/AVP 0
a=rtpmap:0 PCMU/8000
```

F9 ACK GW 1 -> Proxy 1

```
ACK sip:UserB@192.168.200.201 SIP/2.0
Via: SIP/2.0/UDP gw1.atlanta.com:5060;branch=z9hG4bKwqwee65
Max-Forwards: 70
Route: <sip:ss1.atlanta.com;lr>
From: <sip:551313@gw1.atlanta.com;user=phone>;tag=jwdkallkzm
To: <sip:+19725552222@ss1.atlanta.com;user=phone>;tag=314159
Call-ID: 4Fde34wkd11wsGFDS3@gw1.atlanta.com
CSeq: 1 ACK
Content-Length: 0
```

F10 ACK Proxy 1 -> User B

```
ACK sip:UserB@192.168.200.201 SIP/2.0
Via: SIP/2.0/UDP ss1.atlanta.com:5060;branch=z9hG4bK2d4790.1
Via: SIP/2.0/UDP gw1.atlanta.com:5060;branch=z9hG4bKwqwee65
;received=192.168.255.201
Max-Forwards: 69
From: <sip:551313@gw1.atlanta.com;user=phone>;tag=jwdkallkzm
To: <sip:+19725552222@ss1.atlanta.com;user=phone>;tag=314159
Call-ID: 4Fde34wkd11wsGFDS3@ngw1.atlanta.com
CSeq: 1 ACK
Content-Length: 0
```

/\* RTP streams are established between A and B (via the GW) \*/

/\* User A Hangs Up with User B. \*/

F11 BYE GW 1 -> Proxy 1

```
BYE sip:UserB@192.168.200.201 SIP/2.0
Via: SIP/2.0/UDP gw1.atlanta.com:5060;branch=z9hG4bKwqwee65
Max-Forwards: 70
Route: <sip:ss1.atlanta.com;lr>
From: <sip:551313@gw1.atlanta.com;user=phone>;tag=jwdkallkzm
To: <sip:+19725552222@ss1.atlanta.com;user=phone>;tag=314159
Call-ID: 4Fde34wkd11wsGFDS3@gw1.atlanta.com
CSeq: 2 BYE
Content-Length: 0
```



F12 BYE Proxy 1 -> User B

```
BYE sip:UserB@192.168.200.201 SIP/2.0
Via: SIP/2.0/UDP ss1.atlanta.com:5060;branch=z9hG4bK2d4790.1
Via: SIP/2.0/UDP gw1.atlanta.com:5060;branch=z9hG4bKwqwee65
    ;received=192.168.255.201
Max-Forwards: 69
To: <sip:+19725552222@ss1.atlanta.com;user=phone>;tag=314159
Call-ID: 4Fde34wkd11wsGFds3@gw1.atlanta.com
CSeq: 2 BYE
Content-Length: 0
```

F13 200 OK User B -> Proxy 1

```
SIP/2.0 200 OK
Via: SIP/2.0/UDP ss1.atlanta.com:5060;branch=z9hG4bK2d4790.1
    ;received=192.168.255.111
Via: SIP/2.0/UDP gw1.atlanta.com:5060;branch=z9hG4bKwqwee65
    ;received=192.168.255.201
From: <sip:551313@gw1.atlanta.com;user=phone>;tag=jwdkallkzm
To: <sip:+19725552222@ss1.atlanta.com;user=phone>;tag=314159
Call-ID: 4Fde34wkd11wsGFds3@gw1.atlanta.com
CSeq: 2 BYE
Content-Length: 0
```

F14 200 OK Proxy 1 -> GW 1

```
SIP/2.0 200 OK
Via: SIP/2.0/UDP gw1.atlanta.com:5060;branch=z9hG4bKwqwee65
    ;received=192.168.255.201
From: <sip:551313@gw1.atlanta.com;user=phone>;tag=jwdkallkzm
To: <sip:+19725552222@ss1.atlanta.com;user=phone>;tag=314159
Call-ID: 4Fde34wkd11wsGFds3@gw1.atlanta.com
CSeq: 2 BYE
Content-Length: 0
```



**5.2 Failure Scenarios**

**5.2.1 Unsuccessful PSTN to SIP REL, SIP error mapped to REL**

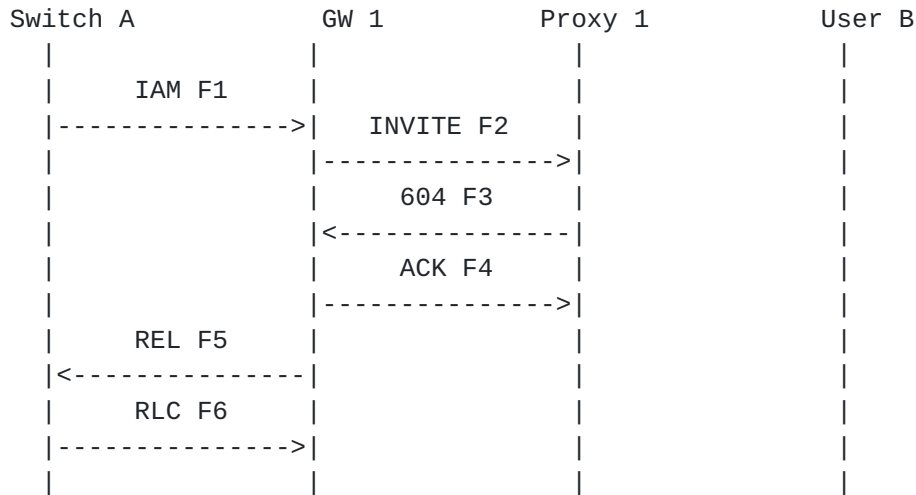

User A attempts to place a call through Gateway GW 1 and Proxy 1, which is unable to find any routing for the number. The call is rejected by Proxy 1 with a REL message containing a specific Cause value mapped by the gateway based on the SIP error.

Message Details

F1 IAM User A -> GW 1

```
IAM
CgPN=314-555-1111,NPI=E.164,NOA=National
CdPN=972-555-9999,NPI=E.164,NOA=National
```

F2 INVITE A -> Proxy 1

```
INVITE sip:+1972559999@ss1.atlanta.com;user=phone SIP/2.0
Via: SIP/2.0/UDP ngw1.atlanta.com:5060;branch=z9hG4bKlueha2
Max-Forwards: 70
From: <sip:+13145551111@gw1.atlanta.com;user=phone>;tag=076342s
To: <sip:+1972559999@ss1.atlanta.com;user=phone>
Call-ID: 4Fde34wkd11wsGFDS3@gw1.atlanta.com
CSeq: 1 INVITE
Contact: <sip:+13145551111@gw1.atlanta.com;user=phone>
Content-Type: application/sdp
Content-Length: 140
```

```
v=0
o=GW 2890844527 2890844527 IN IP4 gw1.atlanta.com
s=-
```

c=IN IP4 192.168.255.201  
t=0 0

Johnston, et al.

Informational

[Page 151]

```
m=audio 3456 RTP/AVP 0
a=rtpmap:0 PCMU/8000
```

```
/* Proxy 1 uses a Location Service to find a route to +1-972-555-
9999. A route is not found, so Proxy 1 rejects the call. */
```

F3 604 Does Not Exist Anywhere Proxy 1 -> GW 1

```
SIP/2.0 604 Does Not Exist Anywhere
Via: SIP/2.0/UDP ngw1.atlanta.com:5060;branch=z9hG4bKlueha2
;received=192.168.255.201
From: <sip:+13145551111@gw1.atlanta.com;user=phone>;tag=076342s
To: <sip:+1972559999@ss1.atlanta.com;user=phone>;tag=6a34d410
Call-ID: 4Fde34wkd11wsGFDS3@gw1.atlanta.com
CSeq: 1 INVITE
Error-Info: <sip:does-not-exist@ann.atlanta.com>
Content-Length: 0
```

F4 ACK GW 1 -> Proxy 1

```
ACK sip:+1972559999@ss1.atlanta.com;user=phone SIP/2.0
Via: SIP/2.0/UDP ngw1.atlanta.com:5060;branch=z9hG4bKlueha2
Max-Forwards: 70
From: <sip:+13145551111@gw1.atlanta.com;user=phone>;tag=076342s
To: <sip:+1972559999@ss1.atlanta.com;user=phone>;tag=6a34d410
Call-ID: 4Fde34wkd11wsGFDS3@gw1.atlanta.com
CSeq: 1 ACK
Content-Length: 0
```

F5 REL GW 1 -> User A

```
REL
CauseCode=1
```

F6 RLC User A -> GW 1

```
RLC
```





**5.2.2 Unsuccessful PSTN to SIP REL, SIP busy mapped to REL**

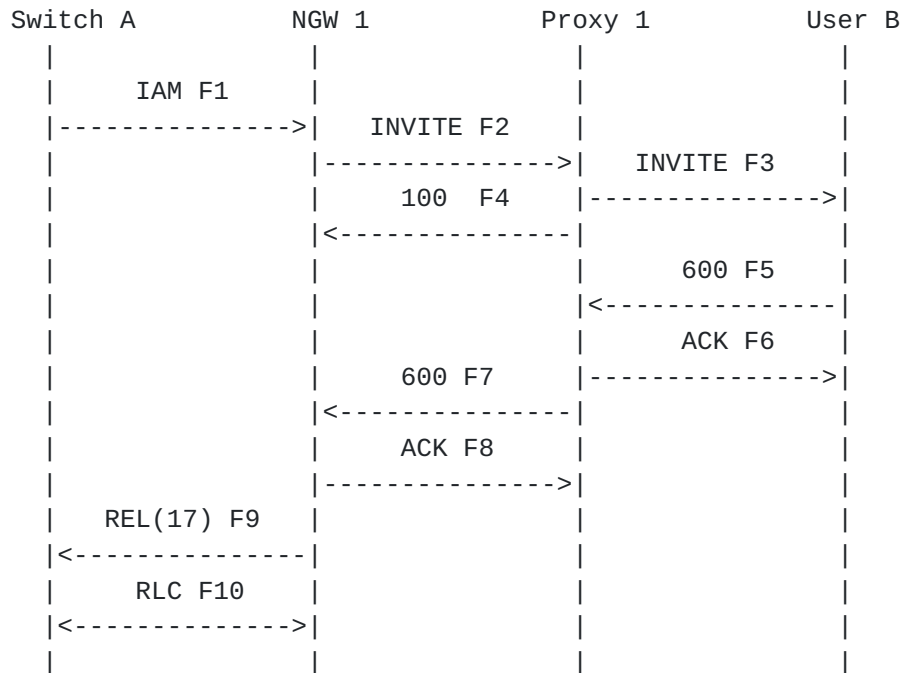

In this scenario, User A calls User B through Network Gateway NGW 1 and Proxy 1. The call is routed to User B by Proxy 1. The call is rejected by User B who sends a 600 Busy Everywhere response. The Gateway sends a REL message containing a specific Cause value mapped by the gateway based on the SIP error.

Since no interworking is indicated in the IAM (F1), the busy tone is generated locally by User A's telephone switch. In scenario 5.2.3, the busy signal is generated by the Gateway since interworking is indicated. For more discussion on interworking, refer to [[SIP-ISUP](#)].

Message Details

F1 IAM User A -> NGW 1

```
IAM
CgPN=314-555-1111,NPI=E.164,NOA=National
CdPN=972-555-2222,NPI=E.164,NOA=National
```

F2 INVITE A -> Proxy 1

```
INVITE sip:+19725552222@ngw1.atlanta.com;user=phone SIP/2.0
Via: SIP/2.0/UDP ngw1.atlanta.com:5060;branch=z9hG4bKlueha2
Max-Forwards: 70
From: <sip:+13145551111@ngw1.atlanta.com;user=phone>;tag=7643kals
```

To: <sip:+19725552222@ss1.atlanta.com;user=phone>  
Call-ID: 4Fde34wkd11wsGFDS3@ngw1.atlanta.com

Johnston, et al.

Informational

[Page 153]

```
CSeq: 1 INVITE
Contact: <sip:+13145551111@ngw1.atlanta.com;user=phone>
Content-Type: application/sdp
Content-Length: 140
```

```
v=0
o=GW 2890844527 2890844527 IN IP4 gw1.atlanta.com
s=-
c=IN IP4 192.168.255.201
t=0 0
m=audio 3456 RTP/AVP 0
a=rtpmap:0 PCMU/8000
```

```
/* Proxy 1 uses a Location Service function to determine a route for
+19725552222. The call is then forwarded to User B. */
```

```
F3 INVITE F3 Proxy 1 -> User B
```

```
INVITE UserB@biloxi.com SIP/2.0
Via: SIP/2.0/UDP ss1.atlanta.com:5060;branch=z9hG4bK2d4790.1
Via: SIP/2.0/UDP ngw1.atlanta.com:5060;branch=z9hG4bKlueha2
;received=192.168.255.201
Max-Forwards: 69
Record-Route: <sip:ss1.atlanta.com;lr>
From: <sip:+13145551111@ngw1.atlanta.com;user=phone>;tag=7643kals
To: <sip:+19725552222@ss1.atlanta.com;user=phone>
Call-ID: 4Fde34wkd11wsGFDS3@ngw1.atlanta.com
CSeq: 1 INVITE
Contact: <sip:+13145551111@ngw1.atlanta.com;user=phone>
Content-Type: application/sdp
Content-Length: 140
```

```
v=0
o=GW 2890844527 2890844527 IN IP4 gw1.atlanta.com
s=-
c=IN IP4 192.168.255.201
t=0 0
m=audio 3456 RTP/AVP 0
a=rtpmap:0 PCMU/8000
```

```
F4 100 Trying Proxy 1 -> NGW 1
```

```
SIP/2.0 100 Trying
Via: SIP/2.0/UDP ngw1.atlanta.com:5060;branch=z9hG4bKlueha2
;received=192.168.255.201
From: <sip:+13145551111@ngw1.atlanta.com;user=phone>;tag=7643kals
To: <sip:+19725552222@ss1.atlanta.com;user=phone>;tag=314159
Call-ID: 4Fde34wkd11wsGFDS3@ngw1.atlanta.com
```

CSeq: 1 INVITE  
Content-Length: 0

Johnston, et al.

Informational

[Page 154]

F5 600 Busy Everywhere User B -> Proxy 1

SIP/2.0 600 Busy Everywhere  
Via: SIP/2.0/UDP ss1.atlanta.com:5060;branch=z9hG4bK2d4790.1  
;received=192.168.255.111  
Via: SIP/2.0/UDP ngw1.atlanta.com:5060;branch=z9hG4bKlueha2  
;received=192.168.255.201  
From: <sip:+13145551111@ngw1.atlanta.com;user=phone>;tag=7643kals  
To: <sip:+19725552222@ss1.atlanta.com;user=phone>;tag=314159  
Call-ID: 4Fde34wkd11wsGFds3@ngw1.atlanta.com  
CSeq: 1 INVITE  
Content-Length: 0

F6 ACK Proxy 1 -> User B

ACK UserB@biloxi.com SIP/2.0  
Via: SIP/2.0/UDP ss1.atlanta.com:5060;branch=z9hG4bK2d4790.1  
Max-Forwards: 70  
From: <sip:+13145551111@ngw1.atlanta.com;user=phone>;tag=7643kals  
To: <sip:+19725552222@ss1.atlanta.com;user=phone>;tag=314159  
Call-ID: 4Fde34wkd11wsGFds3@ngw1.atlanta.com  
CSeq: 1 ACK  
Content-Length: 0

F7 600 Busy Everywhere Proxy 1 -> NGW 1

SIP/2.0 600 Busy Everywhere  
Via: SIP/2.0/UDP ngw1.atlanta.com:5060;branch=z9hG4bKlueha2  
;received=192.168.255.201  
From: <sip:+13145551111@ngw1.atlanta.com;user=phone>;tag=7643kals  
To: <sip:+19725552222@ss1.atlanta.com;user=phone>;tag=314159  
Call-ID: 4Fde34wkd11wsGFds3@ngw1.atlanta.com  
CSeq: 1 INVITE  
Content-Length: 0

F8 ACK NGW 1 -> Proxy 1

ACK UserB@biloxi.com SIP/2.0  
Via: SIP/2.0/UDP ngw1.atlanta.com:5060;branch=z9hG4bKlueha2  
Max-Forwards: 70  
From: <sip:+13145551111@ngw1.atlanta.com;user=phone>;tag=7643kals  
To: <sip:+19725552222@ss1.atlanta.com;user=phone>;tag=314159  
Call-ID: 4Fde34wkd11wsGFds3@ngw1.atlanta.com  
CSeq: 1 ACK  
Content-Length: 0



F9 REL NGW 1 -> User A

REL  
CauseCode=17 Busy

F10 RLC User A -> NGW 1

RLC





**5.2.3 Unsuccessful PSTN->SIP, SIP error interworking to tones**

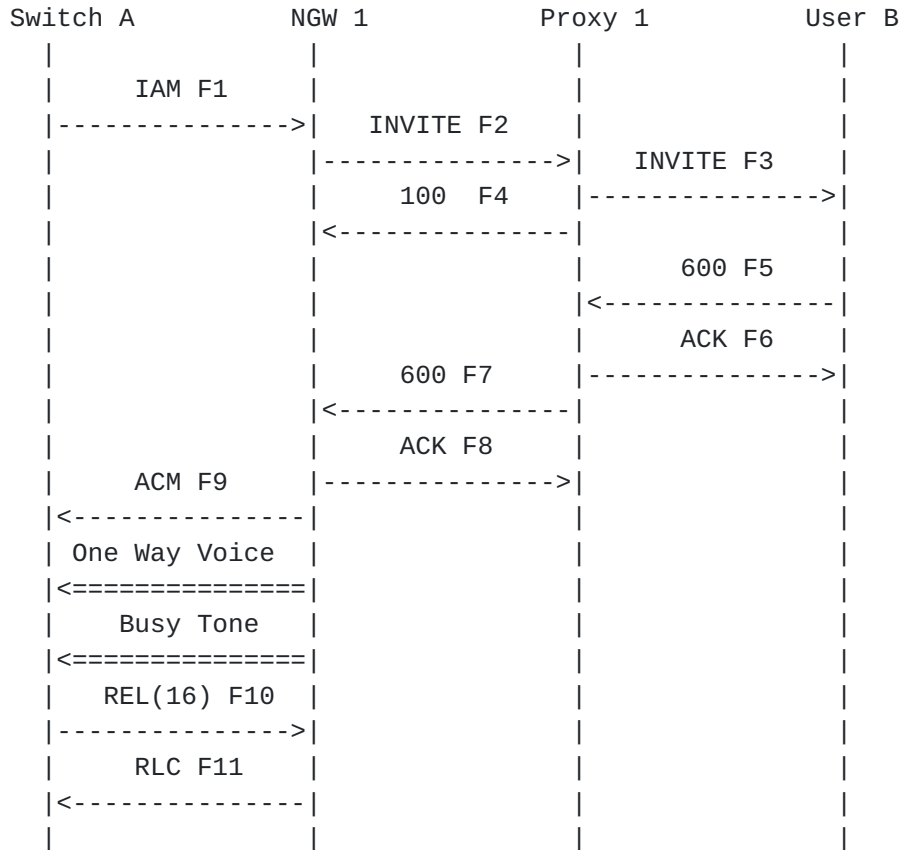

In this scenario, User A calls User B through Network Gateway NGW1 and Proxy 1. The call is routed to User B by Proxy 1. The call is rejected by the User B client. NGW 1 sets up a two way voice path to User A and plays busy tone. The caller then disconnects

NGW 1 plays the busy tone since the IAM (F1) indicates the interworking is present. In scenario 5.2.2, with no interworking, the busy indication is carried in the REL Cause value and is generated locally instead.

Again, note that for ETSI or ITU ISUP, a CONnect message would be sent instead of the Answer Message.

Message Details

F1 IAM User A -> NGW 1

IAM  
 CgPN=314-555-1111,NPI=E.164,NOA=National  
 CdPN=972-555-2222,NPI=E.164,NOA=National

Interworking=encountered

Johnston, et al.

Informational

[Page 157]

F2 INVITE NGW1 -> Proxy 1

```
INVITE sip:+19725552222@ngw1.atlanta.com;user=phone SIP/2.0
Via: SIP/2.0/UDP ngw1.atlanta.com:5060;branch=z9hG4bKlueha2
Max-Forwards: 70
From: <sip:+13145551111@ngw1.atlanta.com;user=phone>;tag=7643kals
To: <sip:+19725552222@ss1.atlanta.com;user=phone>
Call-ID: 4Fde34wkd11wsGFDS3@ngw1.atlanta.com
CSeq: 1 INVITE
Contact: <sip:+13145551111@ngw1.atlanta.com;user=phone>
Content-Type: application/sdp
Content-Length: 141
```

```
v=0
o=GW 2890844527 2890844527 IN IP4 ngw1.atlanta.com
s=-
c=IN IP4 192.168.255.101
t=0 0
m=audio 3456 RTP/AVP 0
a=rtpmap:0 PCMU/8000
```

/\* Proxy 1 uses a Location Service function to determine a route for +19725552222. The call is then forwarded to User B. \*/

F3 INVITE Proxy 1 -> User B

```
INVITE UserB@biloxi.com SIP/2.0
Via: SIP/2.0/UDP ss1.atlanta.com:5060;branch=z9hG4bK2d4790.1
Via: SIP/2.0/UDP ngw1.atlanta.com:5060;branch=z9hG4bKlueha2
;received=192.168.255.101
Max-Forwards: 69
Record-Route: <sip:ss1.atlanta.com;lr>
From: <sip:+13145551111@ngw1.atlanta.com;user=phone>;tag=7643kals
To: <sip:+19725552222@ss1.atlanta.com;user=phone>
Call-ID: 4Fde34wkd11wsGFDS3@ngw1.atlanta.com
CSeq: 1 INVITE
Contact: <sip:+13145551111@ngw1.atlanta.com;user=phone>
Content-Type: application/sdp
Content-Length: 141
```

```
v=0
o=GW 2890844527 2890844527 IN IP4 ngw1.atlanta.com
s=-
c=IN IP4 192.168.255.101
t=0 0
m=audio 3456 RTP/AVP 0
a=rtpmap:0 PCMU/8000
```

F4 100 Trying User B -> Proxy 1

Johnston, et al.

Informational

[Page 158]

SIP/2.0 100 Trying

Via: SIP/2.0/UDP ss1.atlanta.com:5060;branch=z9hG4bK2d4790.1  
;received=192.168.255.111

Via: SIP/2.0/UDP ngw1.atlanta.com:5060;branch=z9hG4bKlueha2  
;received=192.168.255.101

From: <sip:+13145551111@ngw1.atlanta.com;user=phone>;tag=7643kals

To: <sip:+19725552222@ss1.atlanta.com;user=phone>

Call-ID: 4Fde34wkd11wsGFds3@ngw1.atlanta.com

CSeq: 1 INVITE

Content-Length: 0

F5 600 Busy Everywhere User B -> Proxy 1

SIP/2.0 600 Busy Everywhere

Via: SIP/2.0/UDP ss1.atlanta.com:5060;branch=z9hG4bK2d4790.1  
;received=192.168.255.111

Via: SIP/2.0/UDP ngw1.atlanta.com:5060;branch=z9hG4bKlueha2  
;received=192.168.255.101

From: <sip:+13145551111@ngw1.atlanta.com;user=phone>;tag=7643kals

To: <sip:+19725552222@ss1.atlanta.com;user=phone>;tag=314159

Call-ID: 4Fde34wkd11wsGFds3@ngw1.atlanta.com

CSeq: 1 INVITE

Content-Length: 0

F6 ACK Proxy 1 -> User B

ACK UserB@biloxi.com SIP/2.0

Via: SIP/2.0/UDP ss1.atlanta.com:5060;branch=z9hG4bK2d4790.1  
Max-Forwards: 70

From: <sip:+13145551111@ngw1.atlanta.com;user=phone>;tag=7643kals

To: <sip:+19725552222@ss1.atlanta.com;user=phone>;tag=314159

Call-ID: 4Fde34wkd11wsGFds3@ngw1.atlanta.com

CSeq: 1 ACK

Content-Length: 0

F7 600 Busy Everywhere Proxy 1 -> NGW 1

SIP/2.0 600 Busy Everywhere

Via: SIP/2.0/UDP ngw1.atlanta.com:5060;branch=z9hG4bKlueha2  
;received=192.168.255.101

From: <sip:+13145551111@ngw1.atlanta.com;user=phone>;tag=7643kals

To: <sip:+19725552222@ss1.atlanta.com;user=phone>;tag=314159

Call-ID: 4Fde34wkd11wsGFds3@ngw1.atlanta.com

CSeq: 1 INVITE

Content-Length: 0

F8 ACK NGW 1 -> Proxy 1

Johnston, et al.

Informational

[Page 159]

ACK sip:+19725552222@ngw1.atlanta.com;user=phone SIP/2.0  
Via: SIP/2.0/UDP ngw1.atlanta.com:5060;branch=z9hG4bKlueha2  
Max-Forwards: 70  
From: <sip:+13145551111@ngw1.atlanta.com;user=phone>;tag=7643kals  
To: <sip:+19725552222@ss1.atlanta.com;user=phone>;tag=314159  
Call-ID: 4Fde34wkd11wsGFDS3@ngw1.atlanta.com  
CSeq: 1 ACK  
Content-Length: 0

F9 ACM NGW 1 -> User A

ACM

/\* A one way speech path is established between NGW 1 and User A. \*/

/\* Call Released after User A hangs up. \*/

F10 REL User A -> NGW 1

REL

CauseCode=16

F11 RLC NGW 1 -> User A

RLC





**5.2.4 Unsuccessful PSTN->SIP, ACM timeout**

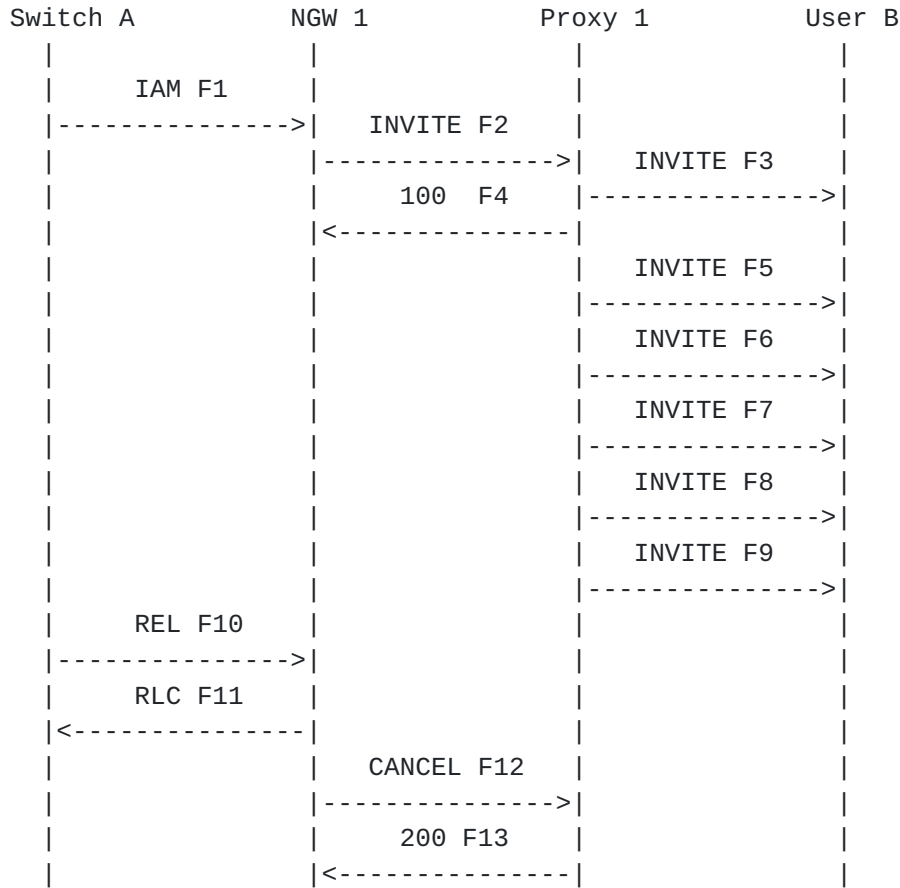

User A calls User B through NGW 1 and Proxy 1. Proxy 1 re-sends the INVITE after the expiration of SIP timer T1 without receiving any response from User B. User B never responds with 180 Ringing or any other response (it is reachable but unresponsive). After the expiration of a timer, User A's network disconnects the call by sending a Release message REL. The Gateway maps this to a CANCEL. Message Details

F1 IAM User A -> NGW 1

IAM  
 CgPN=314-555-1111,NPI=E.164,NOA=National  
 CdPN=972-555-2222,NPI=E.164,NOA=National

F2 INVITE A -> Proxy 1

INVITE sip:+19725552222@ss1.atlanta.com;user=phone SIP/2.0  
 Via: SIP/2.0/UDP ngw1.atlanta.com:5060;branch=z9hG4bKlueha2  
 Max-Forwards: 70  
 From: <sip:+13145551111@ngw1.atlanta.com;user=phone>;tag=7643kals  
 To: <sip:+19725552222@ss1.atlanta.com;user=phone>

Call-ID: 4Fde34wkd11wsGFDS3@ngw1.atlanta.com

CSeq: 1 INVITE

Contact: <sip:+13145551111@ngw1.atlanta.com;user=phone>

Johnston, et al.

Informational

[Page 161]

Content-Type: application/sdp  
Content-Length: 141

v=0  
o=GW 2890844527 2890844527 IN IP4 ngw1.atlanta.com  
s=-  
c=IN IP4 192.168.255.101  
t=0 0  
m=audio 3456 RTP/AVP 0  
a=rtpmap:0 PCMU/8000

/\* Proxy 1 uses a Location Service function to determine a route for  
+19725552222. The call is then forwarded to User B. \*/

F3 INVITE Proxy 1 -> User B

INVITE sip:UserB@biloxi.com SIP/2.0  
Via: SIP/2.0/UDP ss1.atlanta.com:5060;branch=z9hG4bK2d4790.1  
Via: SIP/2.0/UDP ngw1.atlanta.com:5060;branch=z9hG4bKlueha2  
;received=192.168.255.101  
Max-Forwards: 69  
Record-Route: <sip:ss1.atlanta.com;lr>  
From: <sip:+13145551111@ngw1.atlanta.com;user=phone>;tag=7643kals  
To: <sip:+19725552222@ss1.atlanta.com;user=phone>  
Call-ID: 4Fde34wkd11wsGFDS3@ngw1.atlanta.com  
CSeq: 1 INVITE  
Contact: <sip:+13145551111@ngw1.atlanta.com;user=phone>  
Content-Type: application/sdp  
Content-Length: 141

v=0  
o=GW 2890844527 2890844527 IN IP4 ngw1.atlanta.com  
c c=IN IP4 192.168.255.101  
t=0 0  
m=audio 3456 RTP/AVP 0  
a=rtpmap:0 PCMU/8000

F4 100 Trying Proxy 1 -> NGW 1

SIP/2.0 100 Trying  
Via: SIP/2.0/UDP ngw1.atlanta.com:5060;branch=z9hG4bKlueha2  
;received=192.168.255.101  
From: <sip:+13145551111@ngw1.atlanta.com;user=phone>;tag=7643kals  
To: <sip:+19725552222@ss1.atlanta.com;user=phone>  
Call-ID: 4Fde34wkd11wsGFDS3@ngw1.atlanta.com  
CSeq: 1 INVITE  
Content-Length: 0

F5 INVITE Proxy 1 -> User B

Johnston, et al.

Informational

[Page 162]

Same as Message F3

F6 INVITE Proxy 1 -> User B

Same as Message F3

F7 INVITE Proxy 1 -> User B

Same as Message F3

F8 INVITE Proxy 1 -> User B

Same as Message F3

F9 INVITE Proxy 1 -> User B

Same as Message F3

/\* Timer expires in User A's access network. \*/

F10 REL User A -> NGW 1

REL

CauseCode=16 Normal

F11 RLC NGW 1 -> User A

RLC

F12 CANCEL NGW 1 -> Proxy 1

CANCEL sip:+19725552222@ss11.atlanta.com;user=phone SIP/2.0

Via: SIP/2.0/UDP ngw1.atlanta.com:5060;branch=z9hG4bKlueha2

Max-Forwards: 70

From: <sip:+13145551111@ngw1.atlanta.com;user=phone>;tag=7643kals

To: <sip:+19725552222@ss1.atlanta.com;user=phone>

Call-ID: 4Fde34wkd11wsGFDS3@ngw1.atlanta.com

CSeq: 1 CANCEL

Content-Length: 0

F13 200 OK Proxy 1 -> NGW 1

SIP/2.0 200 OK

Via: SIP/2.0/UDP ngw1.atlanta.com:5060;branch=z9hG4bK1ueha2

Johnston, et al.

Informational

[Page 163]

```
;received=192.168.255.101
From: <sip:+13145551111@ngw1.atlanta.com;user=phone>;tag=7643kals
To: <sip:+19725552222@ss1.atlanta.com;user=phone>
Call-ID: 4Fde34wkd11wsGFDS3@ngw1.atlanta.com
CSeq: 1 CANCEL
Content-Length: 0
```





**5.2.5 Unsuccessful PSTN->SIP, ACM timeout, stateless Proxy**

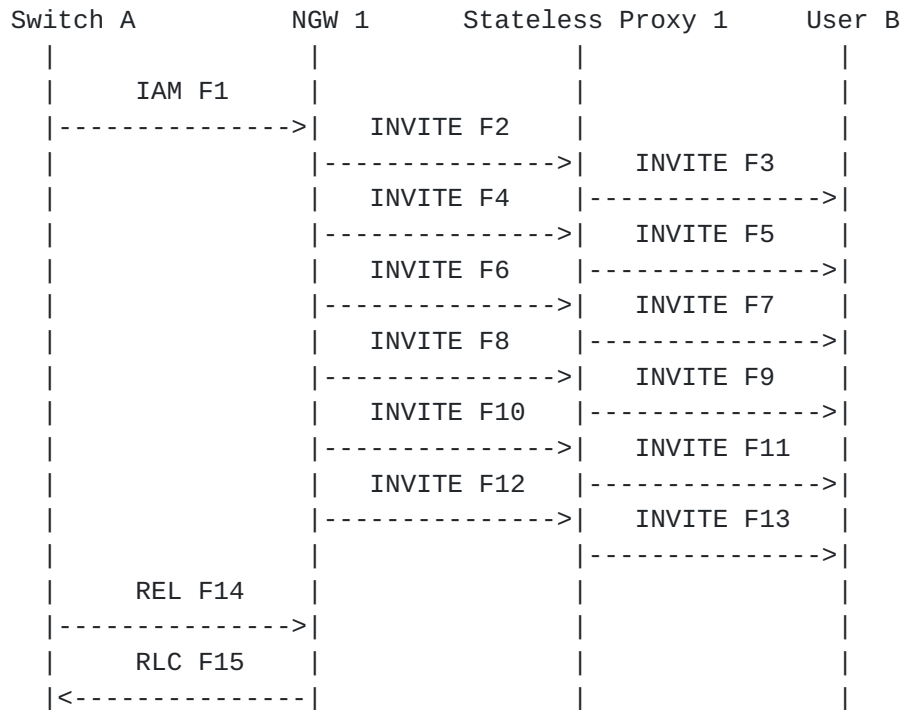

In this scenario, User A calls User B through NGW 1 and Proxy 1. Since Proxy 1 is stateless (it does not send a 100 Trying response), NGW 1 re-sends the INVITE message after the expiration of SIP timer T1. User B does not respond with 180 Ringing. User A's network disconnects the call with a release REL (CauseCode=102 Timeout).

Message Details

F1 IAM User A -> NGW 1

```
IAM
CgPN=314-555-1111,NPI=E.164,NOA=National
CdPN=972-555-2222,NPI=E.164,NOA=National
```

F2 INVITE NGW 1 -> Proxy 1

```
INVITE sip:+19725552222@ss1.atlanta.com;user=phone SIP/2.0
Via: SIP/2.0/UDP ngw1.atlanta.com:5060;branch=z9hG4bKlueha2
Max-Forwards: 70
From: <sip:+13145551111@ngw1.atlanta.com;user=phone>;tag=7643kals
To: <sip:+19725552222@ss1.atlanta.com;user=phone>
Call-ID: 4Fde34wkd11wsGFDS3@ngw1.atlanta.com
CSeq: 1 INVITE
```

Contact: <sip:+13145551111@ngw1.atlanta.com;user=phone>  
Content-Type: application/sdp

Johnston, et al.

Informational

[Page 165]

Content-Length: 141

```
v=0
o=GW 2890844527 2890844527 IN IP4 ngw1.atlanta.com
s=-
c=IN IP4 192.168.255.101
t=0 0
m=audio 3456 RTP/AVP 0
a=rtpmap:0 PCMU/8000
```

/\* Proxy 1 uses a Location Service function to determine a route for +19725552222. The call is then forwarded to User B. \*/

F3 INVITE Proxy 1 -> User B

```
INVITE sip:UserB@biloxi.com SIP/2.0
Via: SIP/2.0/UDP ss1.atlanta.com:5060;branch=z9hG4bK2d4790.1
Via: SIP/2.0/UDP ngw1.atlanta.com:5060;branch=z9hG4bK1ueha2
;received=192.168.255.201
Max-Forwards: 69
From: <sip:+13145551111@ngw1.atlanta.com;user=phone>;tag=7643kals
To: <sip:+19725552222@ss1.atlanta.com;user=phone>
Call-ID: 4Fde34wkd11wsGFds3@ngw1.atlanta.com
CSeq: 1 INVITE
Contact: <sip:+13145551111@ngw1.atlanta.com;user=phone>
Content-Type: application/sdp
Content-Length: 141
```

```
v=0
o=GW 2890844527 2890844527 IN IP4 ngw1.atlanta.com
s=-
c=IN IP4 192.168.255.101
t=0 0
m=audio 3456 RTP/AVP 0
a=rtpmap:0 PCMU/8000
```

F4 INVITE NGW 1 -> Proxy 1

Same as Message F2

F5 INVITE Proxy 1 -> User B

Same as Message F3

F6 INVITE NGW 1 -> Proxy 1

Same as Message F2

Johnston, et al.

Informational

[Page 166]

F7 INVITE Proxy 1 -> User B

Same as Message F3

F8 INVITE NGW 1 -> Proxy 1

Same as Message F2

F9 INVITE Proxy 1 -> User B

Same as Message F3

F10 INVITE NGW 1 -> Proxy 1

Same as Message F2

F11 INVITE Proxy 1 -> User B

Same as Message F3

F12 INVITE NGW 1 -> Proxy 1

Same as Message F2

F13 INVITE Proxy 1 -> User B

Same as Message F3

/\* A timer expires in User A's access network. \*/

F14 REL User A -> NGW 1

REL

CauseCode=102 Timeout

F15 RLC NGW 1 -> User A

RLC



**5.2.6 Unsuccessful PSTN->SIP, Caller Abandonment**

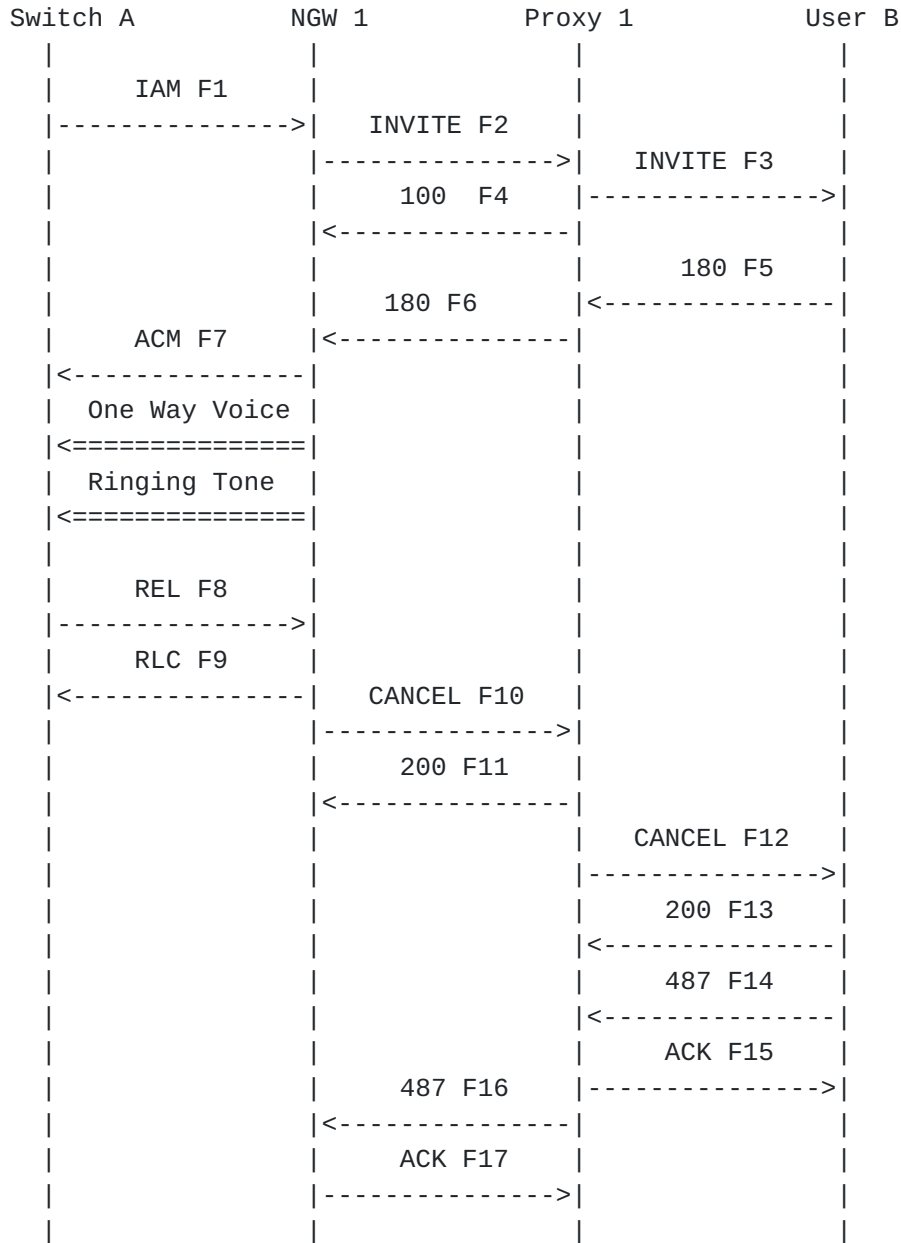

In this scenario, User A calls User B through NGW 1 and Proxy 1. User B does not respond with 200 OK. NGW 1 plays ringing tone since the ACM indicates that interworking has been encountered. User A disconnects the call with a Release message REL which is mapped by NGW 1 to a CANCEL. Note that if User B had sent a 200 OK response after the REL, NGW 1 would have sent an ACK then a BYE to properly terminate the call.

Message Details

F1 IAM User A -> NGW 1

Johnston, et al.

Informational

[Page 168]



IAM

CgPN=314-555-1111,NPI=E.164,NOA=National

CdPN=972-555-2222,NPI=E.164,NOA=National

F2 INVITE A -> Proxy 1

```
INVITE sip:+19725552222@ss1.atlanta.com;user=phone SIP/2.0
Via: SIP/2.0/UDP ngw1.atlanta.com:5060;branch=z9hG4bKlueha2
Max-Forwards: 70
From: <sip:+13145551111@ngw1.atlanta.com;user=phone>;tag=7643kals
To: <sip:+19725552222@ss1.atlanta.com;user=phone>
Call-ID: 4Fde34wkd11wsGFds3@ngw1.atlanta.com
CSeq: 1 INVITE
Contact: <sip:+13145551111@ngw1.atlanta.com;user=phone>
Content-Type: application/sdp
Content-Length: 141
```

v=0

o=GW 2890844527 2890844527 IN IP4 ngw1.atlanta.com

s=-

c=IN IP4 192.168.255.101

t=0 0

m=audio 3456 RTP/AVP 0

a=rtpmap:0 PCMU/8000

```
/* Proxy 1 uses a Location Service function to determine a route for
+19725552222. The call is then forwarded to User B. */
```

F3 INVITE Proxy 1 -> User B

```
INVITE sip:UserB@biloxi.com SIP/2.0
Via: SIP/2.0/UDP ss1.atlanta.com:5060;branch=z9hG4bK2d4790.1
Via: SIP/2.0/UDP ngw1.atlanta.com:5060;branch=z9hG4bKlueha2
;received=192.168.255.101
Max-Forwards: 69
Record-Route: <sip:ss1.atlanta.com;lr>
From: <sip:+13145551111@ngw1.atlanta.com;user=phone>;tag=7643kals
To: <sip:+19725552222@ss1.atlanta.com;user=phone>
Call-ID: 4Fde34wkd11wsGFds3@ngw1.atlanta.com
CSeq: 1 INVITE
Contact: <sip:+13145551111@ngw1.atlanta.com;user=phone>
Content-Type: application/sdp
Content-Length: 141
```

v=0

o=GW 2890844527 2890844527 IN IP4 ngw1.atlanta.com

s=-

c=IN IP4 192.168.255.101  
t=0 0

Johnston, et al.

Informational

[Page 169]

m=audio 3456 RTP/AVP 0  
a=rtpmap:0 PCMU/8000

F4 100 Trying User B -> Proxy 1

SIP/2.0 100 Trying  
Via: SIP/2.0/UDP ss1.atlanta.com:5060;branch=z9hG4bK2d4790.1  
;received=192.168.255.111  
Via: SIP/2.0/UDP ngw1.atlanta.com:5060;branch=z9hG4bKlueha2  
;received=192.168.255.201  
From: <sip:+13145551111@ngw1.atlanta.com;user=phone>;tag=7643kals  
To: <sip:+19725552222@ss1.atlanta.com;user=phone>  
Call-ID: 4Fde34wkd11wsGFds3@ngw1.atlanta.com  
CSeq: 1 INVITE  
Content-Length: 0

F5 180 Ringing User B -> Proxy 1

SIP/2.0 180 Ringing  
Via: SIP/2.0/UDP ss1.atlanta.com:5060;branch=z9hG4bK2d4790.1  
;received=192.168.255.111  
Via: SIP/2.0/UDP ngw1.atlanta.com:5060;branch=z9hG4bKlueha2  
;received=192.168.255.101  
Record-Route: <sip:ss1.atlanta.com;lr>  
From: <sip:+13145551111@ngw1.atlanta.com;user=phone>;tag=7643kals  
To: <sip:+19725552222@ss1.atlanta.com;user=phone>;tag=314159  
Call-ID: 4Fde34wkd11wsGFds3@ngw1.atlanta.com  
CSeq: 1 INVITE  
Contact: <sip:UserB@192.168.200.201>  
Content-Length: 0

F6 180 Ringing Proxy 1 -> NGW 1

SIP/2.0 180 Ringing  
Via: SIP/2.0/UDP ngw1.atlanta.com:5060;branch=z9hG4bKlueha2  
;received=192.168.255.101  
Record-Route: <sip:ss1.atlanta.com;lr>  
From: <sip:+13145551111@ngw1.atlanta.com;user=phone>;tag=7643kals  
To: <sip:+19725552222@ss1.atlanta.com;user=phone>;tag=314159  
Call-ID: 4Fde34wkd11wsGFds3@ngw1.atlanta.com  
CSeq: 1 INVITE  
Contact: <sip:UserB@192.168.200.201>  
Content-Length: 0

F7 ACM NGW 1 -> User A



/\* User A hangs up \*/

F8 REL User A -> NGW 1

REL

CauseCode=16 Normal

F9 RLC NGW 1 -> User A

RLC

F10 CANCEL NGW 1 -> Proxy 1

CANCEL sip:+19725552222@ss1.atlanta.com;user=phone SIP/2.0  
Via: SIP/2.0/UDP ngw1.atlanta.com:5060;branch=z9hG4bKlueha2  
Max-Forwards: 70  
From: <sip:+13145551111@ngw1.atlanta.com;user=phone>;tag=7643kals  
To: <sip:+19725552222@ss1.atlanta.com;user=phone>  
Call-ID: 4Fde34wkd11wsGFDS3@ngw1.atlanta.com  
CSeq: 1 CANCEL  
Content-Length: 0

F11 200 OK Proxy 1 -> NGW 1

SIP/2.0 200 OK  
Via: SIP/2.0/UDP ngw1.atlanta.com:5060;branch=z9hG4bKlueha2  
;received=192.168.255.101  
From: <sip:+13145551111@ngw1.atlanta.com;user=phone>;tag=7643kals  
To: <sip:+19725552222@ss1.atlanta.com;user=phone>  
Call-ID: 4Fde34wkd11wsGFDS3@ngw1.atlanta.com  
CSeq: 1 CANCEL  
Content-Length: 0

F12 CANCEL Proxy 1 -> User B

CANCEL sip:UserB@biloxi.com SIP/2.0  
Via: SIP/2.0/UDP ss1.atlanta.com:5060;branch=z9hG4bK2d4790.1  
Max-Forwards: 70  
From: <sip:+13145551111@ngw1.atlanta.com;user=phone>;tag=7643kals  
To: <sip:+19725552222@ss1.atlanta.com;user=phone>  
Call-ID: 4Fde34wkd11wsGFDS3@ngw1.atlanta.com  
CSeq: 1 CANCEL  
Content-Length: 0

F13 200 OK User B -> Proxy 1

Johnston, et al.

Informational

[Page 171]

SIP/2.0 200 OK  
Via: SIP/2.0/UDP ss1.atlanta.com:5060;branch=z9hG4bK2d4790.1  
;received=192.168.255.111  
From: <sip:+13145551111@ngw1.atlanta.com;user=phone>;tag=7643kals  
To: <sip:+19725552222@ss1.atlanta.com;user=phone>  
Call-ID: 4Fde34wkd11wsGFDS3@ngw1.atlanta.com  
CSeq: 1 CANCEL  
Content-Length: 0

F14 487 Request Terminated User B -> Proxy 1

SIP/2.0 487 Request Terminated  
Via: SIP/2.0/UDP ss1.atlanta.com:5060;branch=z9hG4bK2d4790.1  
;received=192.168.255.111  
Via: SIP/2.0/UDP ngw1.atlanta.com:5060;branch=z9hG4bKlueha2  
;received=192.168.255.101  
From: <sip:+13145551111@ngw1.atlanta.com;user=phone>;tag=7643kals  
To: <sip:+19725552222@ss1.atlanta.com;user=phone>;tag=314159  
Call-ID: 4Fde34wkd11wsGFDS3@ngw1.atlanta.com  
CSeq: 1 INVITE  
Content-Length: 0

F15 ACK Proxy 1 -> User B

ACK sip:UserB@biloxi.com SIP/2.0  
Via: SIP/2.0/UDP ngw1.atlanta.com:5060;branch=z9hG4bKlueha2  
Max-Forwards: 70  
From: <sip:+13145551111@ngw1.atlanta.com;user=phone>;tag=7643kals  
To: <sip:+19725552222@ss1.atlanta.com;user=phone>;tag=314159  
Call-ID: 4Fde34wkd11wsGFDS3@ngw1.atlanta.com  
CSeq: 1 ACK  
Content-Length: 0

F16 487 Request Terminated Proxy 1 -> NGW 1

SIP/2.0 487 Request Terminated  
Via: SIP/2.0/UDP ngw1.atlanta.com:5060;branch=z9hG4bKlueha2  
;received=192.168.255.101  
From: <sip:+13145551111@ngw1.atlanta.com;user=phone>;tag=7643kals  
To: <sip:+19725552222@ss1.atlanta.com;user=phone>;tag=314159  
Call-ID: 4Fde34wkd11wsGFDS3@ngw1.atlanta.com  
CSeq: 1 INVITE  
Content-Length: 0

F17 ACK NGW 1 -> Proxy 1

ACK sip:+19725552222@ss11.atlanta.com;user=phone SIP/2.0  
Via: SIP/2.0/UDP ngw1.atlanta.com:5060;branch=z9hG4bKlueha2

Johnston, et al.

Informational

[Page 172]



Max-Forwards: 70

From: <sip:+13145551111@ngw1.atlanta.com;user=phone>;tag=7643kals

To: <sip:+19725552222@ss1.atlanta.com;user=phone>;tag=314159

Call-ID: 4Fde34wkd11wsGFDS3@ngw1.atlanta.com

CSeq: 1 ACK

Content-Length: 0



## **6 Gateway to Gateway Dialing via SIP Network**

In these scenarios, both the caller and the called party are in the telephone network, either normal PSTN subscribers or PBX extensions. The calls route through two Gateways and at least one SIP Proxy Server. The Proxy Server performs the authentication and location of the Gateways.

Again it is noted that the intent of this call flows document is not to provide a detailed parameter level mapping of SIP to PSTN protocols. For information on SIP to ISUP mapping, the reader is referred to other references [[SIP-ISUP](#)].

### **6.1 Success Scenarios**

In these scenarios, the call is successfully completed between the two Gateways allowing the PSTN or PBX users to communicate. The 183 Session Progress response is used to indicate in-band alerting may flow from the called party telephone switch to the caller.



**6.1.1 Successful ISUP PSTN to ISUP PSTN call**

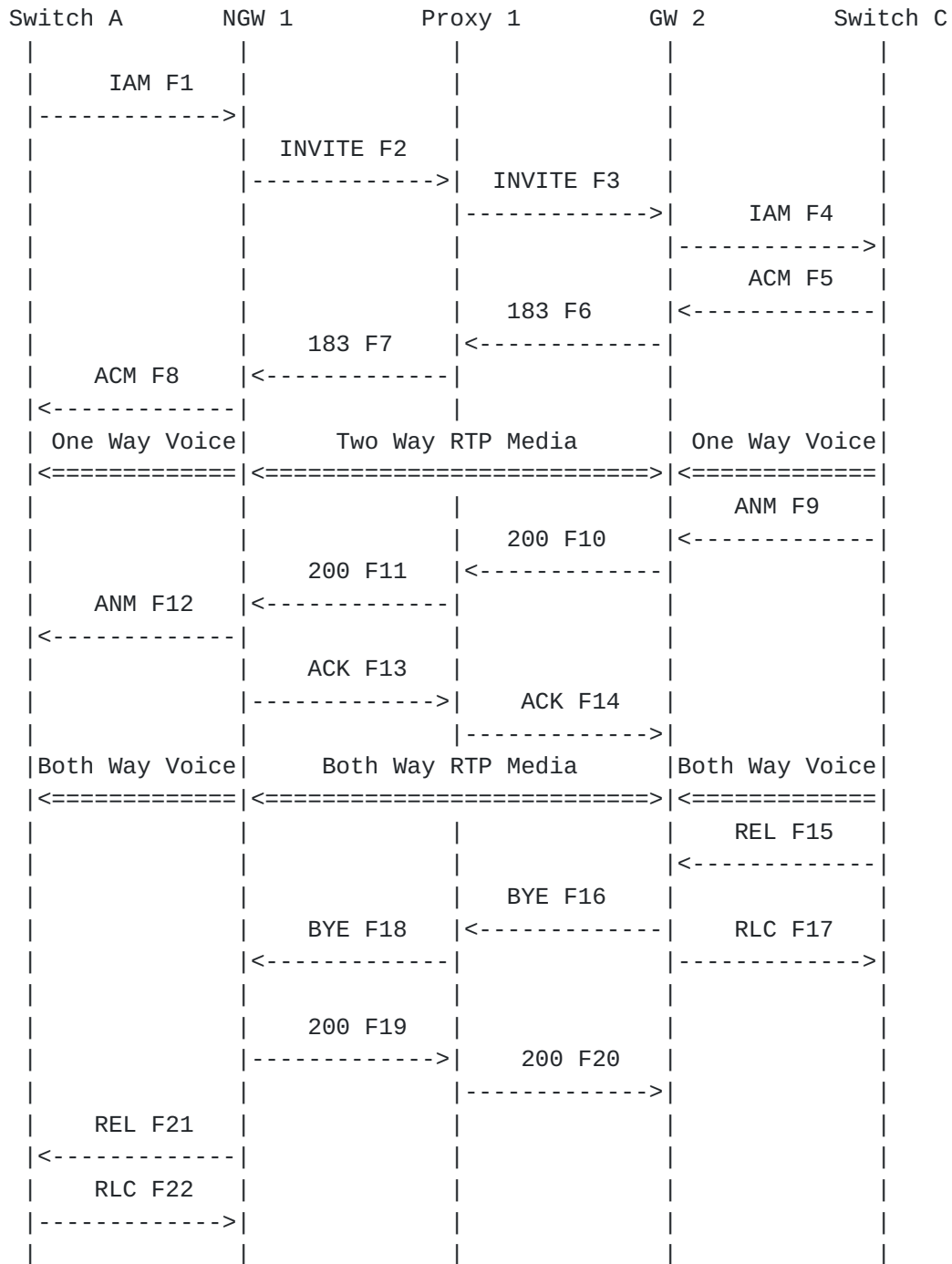

In this scenario, User A in the PSTN calls User C who is an extension on a PBX. User A's telephone switch signals via SS7 to the Network Gateway NGW 1, while User C's PBX signals via SS7 with the Gateway GW 2. The CdPN and CgPN are mapped by GW1 into SIP URIs and placed in the To and From headers. Proxy 1 looks up the dialed digits in the Request-URI and maps the digits to the PBX extension of

User C which is served by GW 2. The Proxy in F3 uses the host portion of the Request-URI to identify what private dialing plan is being referenced. The INVITE is then forwarded to GW 2 for call

completion. An early media path is established end-to-end so that User A can hear the ringing tone generated by PBX C.

User C answers the call and the media path is cut through in both directions. User B hangs up terminating the call.

#### Message Details

F1 IAM Switch A -> NGW 1

IAM

CgPN=314-555-1111,NPI=E.164,NOA=National

CdPN=918-555-3333,NPI=E.164,NOA=National

F2 INVITE NGW 1 -> Proxy 1

INVITE sip:+19185553333@ss1.atlanta.com;user=phone SIP/2.0

Via: SIP/2.0/UDP ngw1.atlanta.com:5060;branch=z9hG4bKlueha2

Max-Forwards: 70

From: <sip:+13145551111@ngw1.atlanta.com;user=phone>;tag=7643kals

To: <sip:+19185553333@ss1.atlanta.com;user=phone>

Call-ID: 2xTb9vxSit55XU7p8@ngw1.atlanta.com

CSeq: 1 INVITE

Contact: <sip:+13145551111@ngw1.atlanta.com;user=phone>

Content-Type: application/sdp

Content-Length: 141

v=0

o=GW 2890844526 2890844526 IN IP4 gw1.atlanta.com

s=-

c=IN IP4 192.168.255.101

t=0 0

m=audio 49172 RTP/AVP 0

a=rtpmap:0 PCMU/8000

/\* Proxy 1 consults Location Service and translates the dialed number to a private number in the Request-URI\*/

F3 INVITE Proxy 1 -> GW 2

INVITE sip:4443333@gw2.atlanta.com SIP/2.0

Via: SIP/2.0/UDP ss1.atlanta.com:5060;branch=z9hG4bK2d4790.1

Via: SIP/2.0/UDP ngw1.atlanta.com:5060;branch=z9hG4bKwqwee65  
;received=192.168.255.101

Max-Forwards: 69

Record-Route: <sip:ss1.atlanta.com;lr>

From: <sip:+13145551111@ngw1.atlanta.com;user=phone>;tag=7643kals

To: <sip:+19185553333@ss1.atlanta.com;user=phone>  
Call-ID: 2xTb9vxSit55XU7p8@ngw1.atlanta.com

Johnston, et al.

Informational

[Page 176]



CSeq: 1 INVITE  
Contact: <sip:+13145551111@ngw1.atlanta.com;user=phone>  
Content-Type: application/sdp  
Content-Length: 141

v=0  
o=GW 2890844526 2890844526 IN IP4 ngw1.atlanta.com  
s=-  
c=IN IP4 192.168.255.101  
t=0 0  
m=audio 49172 RTP/AVP 0  
a=rtpmap:0 PCMU/8000

F4 IAM GW 2 -> Switch C

IAM  
CgPN=314-555-1111,NPI=E.164,NOA=National  
CdPN=444-3333,NPI=Private,NOA=Subscriber

F5 ACM Switch C -> GW 2

ACM

/\* Based on the ACM message, GW 2 returns a 183 response. In-band call progress indications are sent to User A through NGW 1. \*/

F6 183 Session Progress GW 2 -> Proxy 1

SIP/2.0 183 Session Progress  
Via: SIP/2.0/UDP ss1.atlanta.com:5060;branch=z9hG4bK2d4790.1  
;received=192.168.255.111  
Via: SIP/2.0/UDP ngw1.atlanta.com:5060;branch=z9hG4bKlueha2  
;received=192.168.255.101  
Record-Route: <sip:ss1.atlanta.com;lr>  
From: <sip:+13145551111@ngw1.atlanta.com;user=phone>;tag=7643kals  
To: <sip:+19185553333@ss1.atlanta.com;user=phone>;tag=314159  
Call-ID: 2xTb9vxSit55XU7p8@ngw1.atlanta.com  
CSeq: 1 INVITE  
Contact: <sip:4443333@gw2.atlanta.com>  
Content-Type: application/sdp  
Content-Length: 149

v=0  
o=GW 987654321 987654321 IN IP4 gw2.atlanta.com  
s=-  
c=IN IP4 192.168.255.202  
t=0 0

m=audio 14918 RTP/AVP 0  
a=rtpmap:0 PCMU/8000

Johnston, et al.

Informational

[Page 177]

F7 183 Session Progress Proxy 1 -> GW 1

SIP/2.0 183 Session Progress

Via: SIP/2.0/UDP ngw1.atlanta.com:5060;branch=z9hG4bKlueha2  
;received=192.168.255.101

Record-Route: <sip:ss1.atlanta.com;lr>

From: <sip:+13145551111@ngw1.atlanta.com;user=phone>;tag=7643kals

To: <sip:+19185553333@ss1.atlanta.com;user=phone>;tag=314159

Call-ID: 2xTb9vxSit55XU7p8@ngw1.atlanta.com

CSeq: 1 INVITE

Contact: <sip:4443333@gw2.atlanta.com>

Content-Type: application/sdp

Content-Length: 149

v=0

o=GW 987654321 987654321 IN IP4 gw2.atlanta.com

s=-

c=IN IP4 192.168.255.202

t=0 0

m=audio 14918 RTP/AVP 0

a=rtpmap:0 PCMU/8000

/\* NGW 1 receives packets from GW 2 with encoded ringback, tones or  
other audio. NGW 1 decodes this and places it on the originating  
trunk. \*/

F8 ACM NGW 1 -> Switch A

ACM

/\* User B answers \*/

F9 ANM Switch C -> GW 2

ANM

F10 200 OK GW 2 -> Proxy 1

SIP/2.0 200 OK

Via: SIP/2.0/UDP ss1.atlanta.com:5060;branch=z9hG4bK2d4790.1  
;received=192.168.255.111

Via: SIP/2.0/UDP ngw1.atlanta.com:5060;branch=z9hG4bKlueha2  
;received=192.168.255.101

Record-Route: <sip:ss1.atlanta.com;lr>

From: <sip:+13145551111@ngw1.atlanta.com;user=phone>;tag=7643kals

To: <sip:+19185553333@ss1.atlanta.com;user=phone>;tag=314159  
Call-ID: 2xTb9vXSit55XU7p8@ngw1.atlanta.com

Johnston, et al.

Informational

[Page 178]

CSeq: 1 INVITE  
Contact: <sip:4443333@gw2.atlanta.com>  
Content-Type: application/sdp  
Content-Length: 149

v=0  
o=GW 987654321 987654321 IN IP4 gw2.atlanta.com  
s=-  
c=IN IP4 192.168.255.202  
t=0 0  
m=audio 14918 RTP/AVP 0  
a=rtpmap:0 PCMU/8000

F11 200 OK Proxy 1 -> NGW 1

SIP/2.0 200 OK  
Via: SIP/2.0/UDP ngw1.atlanta.com:5060;branch=z9hG4bKlueha2  
;received=192.168.255.101  
Record-Route: <sip:ss1.atlanta.com;lr>  
From: <sip:+13145551111@ngw1.atlanta.com;user=phone>;tag=7643kals  
To: <sip:+19185553333@ss1.atlanta.com;user=phone>;tag=314159  
Call-ID: 2xTb9vxSit55XU7p8@ngw1.atlanta.com  
CSeq: 1 INVITE  
Contact: <sip:4443333@gw2.atlanta.com>  
Content-Type: application/sdp  
Content-Length: 149

v=0  
o=GW 987654321 987654321 IN IP4 gw2.atlanta.com  
s=-  
c=IN IP4 192.168.255.202  
t=0 0  
m=audio 14918 RTP/AVP 0  
a=rtpmap:0 PCMU/8000

F12 ANM NGW 1 -> Switch A

ANM

F13 ACK NGW 1 -> Proxy 1

ACK sip:4443333@gw2.atlanta.com SIP/2.0  
Via: SIP/2.0/UDP ngw1.atlanta.com:5060;branch=z9hG4bKlueha2  
Max-Forwards: 70  
Route: <sip:ss1.atlanta.com;lr>  
From: <sip:+13145551111@ngw1.atlanta.com;user=phone>;tag=7643kals

To: <sip:+19185553333@ss1.atlanta.com;user=phone>;tag=314159  
Call-ID: 2xTb9vXsit55XU7p8@gw1.atlanta.com

Johnston, et al.

Informational

[Page 179]

CSeq: 1 ACK  
Content-Length: 0

F14 ACK Proxy 1 -> GW 2

ACK sip:4443333@gw2.atlanta.com SIP/2.0  
Via: SIP/2.0/UDP ss1.atlanta.com:5060;branch=z9hG4bK2d4790.1  
Via: SIP/2.0/UDP ngw1.atlanta.com:5060;branch=z9hG4bKlueha2  
;received=192.168.255.101  
Max-Forwards: 69  
From: <sip:+13145551111@ngw1.atlanta.com;user=phone>;tag=7643kals  
To: <sip:+19185553333@ss1.atlanta.com;user=phone>;tag=314159  
Call-ID: 2xTb9vxSit55XU7p8@ngw1.atlanta.com  
CSeq: 1 ACK  
Content-Length: 0

/\* RTP streams are established between NGW 1 and GW 2. \*/

/\* User B Hangs Up with User A. \*/

F15 REL Switch C -> GW 2

REL  
CauseCode=16 Normal

F16 BYE GW 2 -> Proxy 1

BYE sip:+13145551111@ngw1.atlanta.com;user=phone SIP/2.0  
Via: SIP/2.0/UDP gw2.atlanta.com:5060;branch=z9hG4bKtexp6  
Max-Forwards: 70  
Route: <sip:ss1.atlanta.com;lr>  
From: <sip:+19185553333@ss1.atlanta.com;user=phone>;tag=314159  
To: <sip:+13145551111@ngw1.atlanta.com;user=phone>;tag=7643kals  
Call-ID: 2xTb9vxSit55XU7p8@ngw1.atlanta.com  
CSeq: 4 BYE  
Content-Length: 0

F17 RLC GW 2 -> Switch C

RLC

F18 BYE Proxy 1 -> NGW 1

BYE sip:+13145551111@ngw1.atlanta.com;user=phone SIP/2.0  
Via: SIP/2.0/UDP ss1.atlanta.com:5060;branch=z9hG4bK2d4790.1

Via: SIP/2.0/UDP gw2.atlanta.com:5060;branch=z9hG4bKtexp6  
;received=192.168.255.202

Johnston, et al.

Informational

[Page 180]



Max-Forwards: 69  
From: <sip:+19185553333@ss1.atlanta.com;user=phone>;tag=314159  
To: <sip:+13145551111@ngw1.atlanta.com;user=phone>;tag=7643kals  
Call-ID: 2xTb9vxSit55XU7p8@ngw1.atlanta.com  
CSeq: 4 BYE  
Content-Length: 0

F19 200 OK NGW 1 -> Proxy 1

SIP/2.0 200 OK  
Via: SIP/2.0/UDP ss1.atlanta.com:5060;branch=z9hG4bK2d4790.1  
;received=192.168.255.111  
Via: SIP/2.0/UDP gw2.atlanta.com:5060;branch=z9hG4bKt6xx6  
;received=192.168.255.202  
From: <sip:+19185553333@ss1.atlanta.com;user=phone>;tag=314159  
To: <sip:+13145551111@ngw1.atlanta.com;user=phone>;tag=7643kals  
Call-ID: 2xTb9vxSit55XU7p8@ngw1.atlanta.com  
CSeq: 4 BYE  
Content-Length: 0

F20 200 OK Proxy 1 -> GW 2

SIP/2.0 200 OK  
Via: SIP/2.0/UDP gw2.atlanta.com:5060;branch=z9hG4bKt6xx6  
;received=192.168.255.202  
From: <sip:+19185553333@ss1.atlanta.com;user=phone>;tag=314159  
To: <sip:+13145551111@ngw1.atlanta.com;user=phone>;tag=7643kals  
Call-ID: 2xTb9vxSit55XU7p8@ngw1.atlanta.com  
CSeq: 4 BYE  
Content-Length: 0

F21 REL Switch C -> GW 2

REL  
CauseCode=16 Normal

F22 RLC GW 2 -> Switch C

RLC



**6.1.2 Successful FGB PBX to ISDN PBX call with overflow**

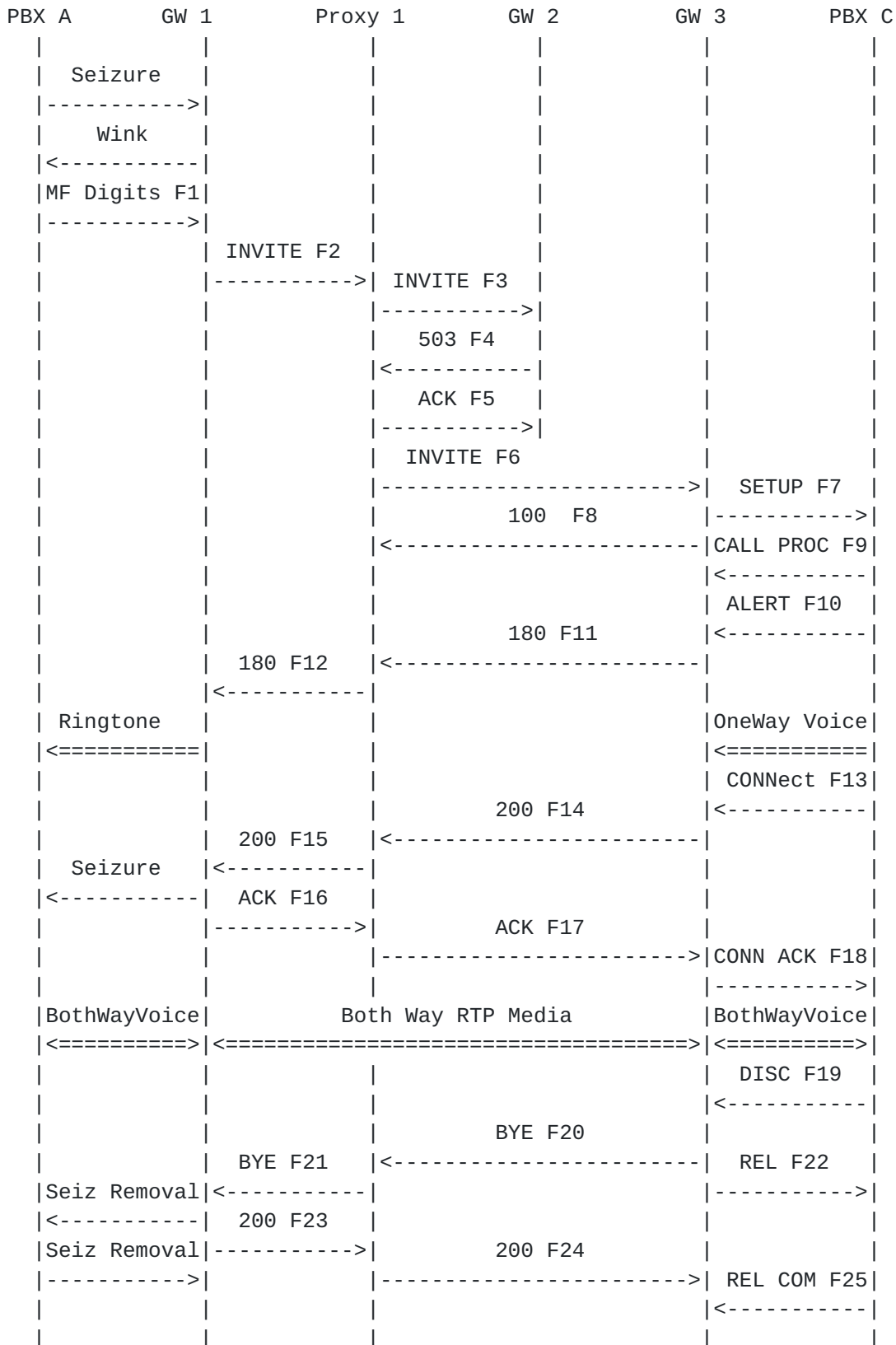

PBX User A calls PBX User C via Gateway GW 1 and Proxy 1. During the

Johnston, et al.

Informational

[Page 182]

attempt to reach User C via GW 2, an error is encountered - Proxy 1 receives a 503 Service Unavailable (F4) response to the forwarded INVITE. This could be due to all circuits being busy, or some other outage at GW 2. Proxy 1 recognizes the error and uses an alternative route via GW 3 to terminate the call. From there, the call proceeds normally with User C answering the call. The call is terminated when User C hangs up.

#### Message Details

PBX A -> GW 1

Seizure

GW 1 -> PBX A

Wink

F1 MF Digits PBX A -> GW 1

KP 444 3333 ST

F2 INVITE GW 1 -> Proxy 1

```
INVITE sip:4443333@ss1.atlanta.com SIP/2.0
Via: SIP/2.0/UDP gw1.atlanta.com:5060;branch=z9hG4bKwqwee65
Max-Forwards: 70
From: <sip:551313@gw1.atlanta.com>;tag=63412s
To: <sip:4443333@ss1.atlanta.com>
Call-ID: 2xTb9vxSit55XU7p8@gw1.atlanta.com
CSeq: 1 INVITE
Contact: <sip:551313@gw1.atlanta.com>
Content-Type: application/sdp
Content-Length: 141
```

```
v=0
o=GW 2890844526 2890844526 IN IP4 gw1.atlanta.com
s=-
c=IN IP4 192.168.255.201
t=0 0
m=audio 49172 RTP/AVP 0
a=rtpmap:0 PCMU/8000
```

/\* Proxy 1 uses a Location Service function to determine where B is located. Response is returned listing alternative routes, GW2 and

GW3, which are then tried sequentially. \*/

Johnston, et al.

Informational

[Page 183]

F3 INVITE Proxy 1 -> GW 2

```
INVITE sip:4443333@gw2.atlanta.com SIP/2.0
Via: SIP/2.0/UDP ss1.atlanta.com:5060;branch=z9hG4bK2d4790.1
Via: SIP/2.0/UDP gw1.atlanta.com:5060;branch=z9hG4bKwqwee65
   ;received=192.168.255.201
Max-Forwards: 69
Record-Route: <sip:ss1.atlanta.com;lr>
From: <sip:551313@gw1.atlanta.com>;tag=63412s
To: <sip:4443333@ss1.atlanta.com>
Call-ID: 2xTb9vxSit55XU7p8@gw1.atlanta.com
CSeq: 1 INVITE
Contact: <sip:551313@gw1.atlanta.com>
Content-Type: application/sdp
Content-Length: 141
```

```
v=0
o=GW 2890844526 2890844526 IN IP4 gw1.atlanta.com
s=-
c=IN IP4 192.168.255.201
t=0 0
m=audio 49172 RTP/AVP 0
a=rtpmap:0 PCMU/8000
```

F4 503 Service Unavailable GW 2 -> Proxy 1

```
SIP/2.0 503 Service Unavailable
Via: SIP/2.0/UDP ss1.atlanta.com:5060;branch=z9hG4bK2d4790.1
   ;received=192.168.255.111
Via: SIP/2.0/UDP gw1.atlanta.com:5060;branch=z9hG4bKwqwee65
   ;received=192.168.255.201
From: <sip:551313@gw1.atlanta.com>;tag=63412s
To: <sip:4443333@ss1.atlanta.com>;tag=314159
Call-ID: 2xTb9vxSit55XU7p8@gw1.atlanta.com
CSeq: 1 INVITE
Content-Length: 0
```

F5 ACK Proxy 1 -> GW 2

```
ACK sip:4443333@ss1.atlanta.com SIP/2.0
Via: SIP/2.0/UDP ss1.atlanta.com:5060;branch=z9hG4bK2d4790.1
Via: SIP/2.0/UDP gw1.atlanta.com:5060;branch=z9hG4bKwqwee65
   ;received=192.168.255.201
Max-Forward: 70
From: <sip:551313@gw1.atlanta.com>;tag=63412s
To: <sip:4443333@ss1.atlanta.com>;tag=314159
Call-ID: 2xTb9vxSit55XU7p8@gw1.atlanta.com
```

CSeq: 1 ACK  
Content-Length: 0

Johnston, et al.

Informational

[Page 184]



F6 INVITE Proxy 1 -> GW 3

INVITE sip:+19185553333@gw3.atlanta.com;user=phone SIP/2.0  
Via: SIP/2.0/UDP ss1.atlanta.com:5060;branch=z9hG4bK2d4790.2  
Via: SIP/2.0/UDP gw1.atlanta.com:5060;branch=z9hG4bKwqwee65  
;received=192.168.255.201  
Max-Forwards: 69  
Record-Route: <sip:ss1.atlanta.com;lr>  
From: <sip:551313@gw1.atlanta.com>;tag=63412s  
To: <sip:4443333@ss1.atlanta.com>  
Call-ID: 2xTb9vxSit55XU7p8@gw1.atlanta.com  
CSeq: 1 INVITE  
Contact: <sip:551313@gw1.atlanta.com>  
Content-Type: application/sdp  
Content-Length: 141

v=0  
o=GW 2890844526 2890844526 IN IP4 gw1.atlanta.com  
s=-  
c=IN IP4 192.168.255.201  
t=0 0  
m=audio 49172 RTP/AVP 0  
a=rtpmap:0 PCMU/8000

F7 SETUP GW 3 -> PBX C

Protocol discriminator=Q.931  
Message type=SETUP  
Bearer capability: Information transfer capability=0 (Speech) or 16  
(3.1 kHz audio)  
Channel identification=Preferred or exclusive B-channel  
Progress indicator=1 (Call is not end-to-end ISDN; further call  
progress information may be available inband)  
Called party number:  
Type of number and numbering plan ID=33 (National number in ISDN  
numbering plan)  
Digits=918-555-3333

F8 100 Trying GW 3 -> Proxy 1

SIP/2.0 100 Trying  
Via: SIP/2.0/UDP gw1.atlanta.com:5060;branch=z9hG4bKwqwee65  
;received=192.168.255.201  
From: <sip:551313@gw1.atlanta.com>;tag=63412s  
To: <sip:4443333@ss1.atlanta.com>  
Call-ID: 2xTb9vxSit55XU7p8@gw1.atlanta.com  
CSeq: 1 INVITE

Content-Length: 0

Johnston, et al.

Informational

[Page 185]

F9 CALL PROCeeding PBX C -> GW 3

Protocol discriminator=Q.931  
Message type=CALL PROC

F10 ALERT PBX C -> GW 3

Protocol discriminator=Q.931  
Message type=PROG

/\* Based on ALERT message, GW 3 returns a 180 response. \*/

F11 180 Ringing GW 3 -> Proxy 1

SIP/2.0 180 Ringing  
Via: SIP/2.0/UDP ss1.atlanta.com:5060;branch=z9hG4bK2d4790.2  
;received=192.168.255.111  
Via: SIP/2.0/UDP gw1.atlanta.com:5060;branch=z9hG4bKwqwee65  
;received=192.168.255.201  
Record-Route: <sip:ss1.atlanta.com;lr>  
From: <sip:551313@gw1.atlanta.com>;tag=63412s  
To: <sip:4443333@ss1.atlanta.com>;tag=123456789  
Call-ID: 2xTb9vxSit55XU7p8@gw1.atlanta.com  
CSeq: 1 INVITE  
Contact: <sip:+19185553333@gw3.atlanta.com;user=phone>  
Content-Length: 0

F12 180 Ringing Proxy 1 -> GW 1

SIP/2.0 180 Ringing  
Via: SIP/2.0/UDP gw1.atlanta.com:5060;branch=z9hG4bKwqwee65  
;received=192.168.255.201  
Record-Route: <sip:ss1.atlanta.com;lr>  
From: <sip:551313@gw1.atlanta.com>;tag=63412s  
To: <sip:4443333@ss1.atlanta.com>;tag=123456789  
Call-ID: 2xTb9vxSit55XU7p8@gw1.atlanta.com  
CSeq: 1 INVITE  
Contact: <sip:+19185553333@gw3.atlanta.com;user=phone>  
Content-Length: 0

F13 CONNect PBX C -> GW 3

Protocol discriminator=Q.931  
Message type=CONN

F14 200 OK GW 3 -> Proxy 1

Johnston, et al.

Informational

[Page 186]

SIP/2.0 200 OK  
Via: SIP/2.0/UDP ss1.atlanta.com:5060;branch=z9hG4bK2d4790.2  
;received=192.168.255.111  
Via: SIP/2.0/UDP gw1.atlanta.com:5060;branch=z9hG4bKwqwee65  
;received=192.168.255.201  
Record-Route: <sip:ss1.atlanta.com;lr>  
From: <sip:551313@gw1.atlanta.com>;tag=63412s  
To: <sip:4443333@ss1.atlanta.com>;tag=123456789  
Call-ID: 2xTb9vxSit55XU7p8@gw1.atlanta.com  
CSeq: 1 INVITE  
Contact: <sip:+19185553333@gw3.atlanta.com;user=phone>  
Content-Type: application/sdp  
Content-Length: 149

v=0  
o=GW 987654321 987654321 IN IP4 gw3.atlanta.com  
s=-  
c=IN IP4 192.168.255.203  
t=0 0  
m=audio 14918 RTP/AVP 0  
a=rtpmap:0 PCMU/8000

F15 200 OK Proxy 1 -> GW 1

SIP/2.0 200 OK  
Via: SIP/2.0/UDP gw1.atlanta.com:5060;branch=z9hG4bKwqwee65  
;received=192.168.255.201  
Record-Route: <sip:ss1.atlanta.com;lr>  
From: <sip:551313@gw1.atlanta.com>;tag=63412s  
To: <sip:4443333@ss1.atlanta.com>;tag=123456789  
Call-ID: 2xTb9vxSit55XU7p8@gw1.atlanta.com  
CSeq: 1 INVITE  
Contact: <sip:+19185553333@gw3.atlanta.com;user=phone>  
Content-Type: application/sdp  
Content-Length: 149

v=0  
o=GW 987654321 987654321 IN IP4 gw3.atlanta.com  
s=-  
c=IN IP4 192.168.255.203  
t=0 0  
m=audio 14918 RTP/AVP 0  
a=rtpmap:0 PCMU/8000

GW 1 -> PBX A

Seizure



F16 ACK GW 1 -> Proxy 1

ACK sip:+19185553333@gw3.atlanta.com;user=phone SIP/2.0  
Via: SIP/2.0/UDP gw1.atlanta.com:5060;branch=z9hG4bKwqwee65  
Max-Forwards: 70  
Route: <sip:ss1.atlanta.com;lr>  
From: <sip:551313@gw1.atlanta.com>;tag=63412s  
To: <sip:4443333@ss1.atlanta.com>;tag=123456789  
Call-ID: 2xTb9vxSit55XU7p8@gw1.atlanta.com  
CSeq: 1 ACK  
Content-Length: 0

F17 ACK Proxy 1 -> GW 3

ACK sip:+19185553333@gw3.atlanta.com;user=phone SIP/2.0  
Via: SIP/2.0/UDP ss1.atlanta.com:5060;branch=z9hG4bK2d4790.2  
Via: SIP/2.0/UDP gw1.atlanta.com:5060;branch=z9hG4bKwqwee65  
;received=192.168.255.201  
Max-Forwards: 69  
From: <sip:551313@gw1.atlanta.com>;tag=63412s  
To: <sip:4443333@ss1.atlanta.com>;tag=123456789  
Call-ID: 2xTb9vxSit55XU7p8@gw1.atlanta.com  
CSeq: 1 ACK  
Content-Length: 0

F18 CONNect ACK GW 3 -> PBX C

Protocol discriminator=Q.931  
Message type=CONN ACK

/\* RTP streams are established between GW 1 and GW 3. \*/

/\* User B Hangs Up with User A. \*/

F19 DISConnect PBX C -> GW 3

Protocol discriminator=Q.931  
Message type=DISC  
Cause=16 (Normal clearing)

F20 BYE GW 3 -> Proxy 1

BYE sip:551313@gw1.atlanta.com SIP/2.0  
Via: SIP/2.0/UDP gw3.atlanta.com:5060;branch=z9hG4bKkdjuwq  
Max-Forwards: 70  
Route: <sip:ss1.atlanta.com;lr>

From: <sip:4443333@ss1.atlanta.com>;tag=123456789  
To: <sip:551313@gw1.atlanta.com>;tag=63412s

Johnston, et al.

Informational

[Page 188]



Call-ID: 2xTb9vxSit55XU7p8@gw1.atlanta.com  
CSeq: 1 BYE  
Content-Length: 0

F21 BYE Proxy 1 -> GW 1

BYE sip:551313@gw1.atlanta.com SIP/2.0  
Via: SIP/2.0/UDP ss1.atlanta.com:5060;branch=z9hG4bK2d4790.2  
Via: SIP/2.0/UDP gw3.atlanta.com:5060;branch=z9hG4bKkdjuwq  
;received=192.168.255.203  
Max-Forwards: 69  
From: <sip:4443333@ss1.atlanta.com>;tag=123456789  
To: <sip:551313@gw1.atlanta.com>;tag=63412s  
Call-ID: 2xTb9vxSit55XU7p8@gw1.atlanta.com  
CSeq: 1 BYE  
Content-Length: 0

GW 1 -> PBX A

Seizure removal

F22 RELEase GW 3 -> PBX C

Protocol discriminator=Q.931  
Message type=REL

F23 200 OK GW 1 -> Proxy 1

SIP/2.0 200 OK  
Via: SIP/2.0/UDP ss1.atlanta.com:5060;branch=z9hG4bK2d4790.2  
;received=192.168.255.111  
Via: SIP/2.0/UDP gw3.atlanta.com:5060;branch=z9hG4bKkdjuwq  
;received=192.168.255.203  
From: <sip:4443333@ss1.atlanta.com>;tag=123456789  
To: <sip:551313@gw1.atlanta.com>;tag=63412s  
Call-ID: 2xTb9vxSit55XU7p8@gw1.atlanta.com  
CSeq: 1 BYE  
Content-Length: 0

F24 200 OK Proxy 1 -> GW 3

SIP/2.0 200 OK  
Via: SIP/2.0/UDP gw3.atlanta.com:5060;branch=z9hG4bKkdjuwq  
;received=192.168.255.203  
From: <sip:4443333@ss1.atlanta.com>;tag=123456789

To: <sip:551313@gw1.atlanta.com>;tag=63412s  
Call-ID: 2xTb9vxSit55XU7p8@gw1.atlanta.com

Johnston, et al.

Informational

[Page 189]

CSeq: 1 BYE  
Content-Length: 0

F25 RELease COMplete PBX C -> GW 3

Protocol discriminator=Q.931  
Message type=REL COM

PBX A -> GW 1

Seizure removal



## [7 SIP Test Messages](#)

The files in here are test messages for SIP servers to exercise various functions. They have been used in SIPit interoperability events. All messages shown here are valid, unless otherwise noted. The correct behavior of servers and clients is also described.

### [7.1 INVITE Parser Torture Test Message](#)

This message is a correctly formatting SIP message. It contains:

line folding all over  
 escaped characters within quotes  
 LWS between colons, semicolons, headers, and other fields  
 both comma separated and separate listing of headers  
 mix or short and long form for the same header  
 unknown header field  
 unusual header ordering  
 unknown parameters of a known header

Proxies should forward message and clients should respond as to a normal INVITE message.

#### Message Details

```

INVITE sip:vivekg@chair.dnrc.bell-labs.com SIP/2.0
TO :
  sip:vivekg@chair.dnrc.bell-labs.com ; tag = 1918181833n
From : "J Rosenberg \\" <sip:jdrosen@lucent.com>
  ;
  tag = 98asjd8
Max-Forwards: 6
Call-ID
  : 0ha0isndaksdj@10.1.1.1
cseq: 8
  INVITE
Via : SIP / 2.0
  /UDP
  135.180.130.133;branch=z9hG4bKkdjuw
Subject :
NewFangledHeader: newfangled value
  more newfangled value
Content-Type: application/sdp
v: SIP / 2.0 / TCP 1192.168.156.222 ;
  branch = 9ikj8 ,
  SIP / 2.0 / UDP 192.168.255.111 ; hidden
m:"Quoted string \\" <sip:jdrosen@bell-labs.com> ; newparam =

```

newvalue ;  
secondparam = secondvalue ; q = 0.33,  
tel:4443322

Johnston, et al.

Informational

[Page 191]

```
v=0
o=mhandley 29739 7272939 IN IP4 126.5.4.3
s=-
c=IN IP4 135.180.130.88
t=0 0
m=audio 492170 RTP/AVP 0 12
m=video 3227 RTP/AVP 31
a=rtpmap:31 LPC
```

## **7.2 INVITE with Proxy-Require and Require**

This message tests support for Proxy-Require and Require. It is a request that contains both headers, listing new features.

Proxies and clients should respond with a 420 Bad Extension, and an Unsupported header listing these features.

### Message Details

```
INVITE sip:user@company.com SIP/2.0
To: sip:j_user@company.com
From: sip:caller@university.edu;tag=242etr
Max-Forward: 6
Call-ID: 0ha0isndaksdj@10.1.1.1
Require: newfeature1, newfeature2
Proxy-Require: newfeature3, newfeature4
CSeq: 8 INVITE
Via: SIP/2.0/UDP 135.180.130.133;branch=z9hG4bKkdjuw
```

## **7.3 INVITE with Unknown Schemes in URIs**

This message contains unknown schemes in the Request URI, To, From and Contact headers of a request.

A server should probably return a not found error; but other behaviors are acceptable.

### Message Details

```
INVITE name:John_Smith SIP/2.0
To: isbn:2983792873
From: <http://www.cs.columbia.edu>;tag=3234233
Call-ID: 0ha0isndaksdj@10.1.2.3
CSeq: 8 INVITE
Max-Forward: 7
Via: SIP/2.0/UDP 135.180.130.133:5060;branch=z9hG4bKkdjuw
```

Content-Type: application/sdp

Johnston, et al.

Informational

[Page 192]



```
v=0
o=mhandley 29739 7272939 IN IP4 126.5.4.3
s=-
c=IN IP4 135.180.130.88
t=0 0
m=audio 492170 RTP/AVP 0 12
m=video 3227 RTP/AVP 31
a=rtpmap:31 LPC
```

#### **7.4 REGISTER with Y2038 Test**

This message is a registration request with an expiration year of 2040. This makes sure that a server doesn't crash on seeing a date past Y2038.

The correct behavior is probably to limit the lifetime to some configured maximum.

##### Message Details

```
REGISTER sip:company.com SIP/2.0
To: sip:user@company.com
From: sip:user@company.com;tag=3411345
Max-Forwards: 8
Contact: sip:user@host.company.com
Call-ID: 0ha0isndaksdj@10.0.0.1
CSeq: 8 REGISTER
Via: SIP/2.0/UDP 135.180.130.133;branch=z9hG4bKkdjuw
Expires: Sat, 01 Dec 2040 16:00:00 GMT
```

#### **7.5 INVITE with inconsistent Accept and message body**

This is a UAS test. It is a request that includes an Accept header without SDP. The UAS should respond with an error.

##### Message Details

```
INVITE sip:user@company.com SIP/2.0
To: sip:j_user@company.com
From: sip:caller@university.edu;tag=234
Max-Forwards: 5
Call-ID: 0ha0isndaksdj@10.0.0.1
Accept: text/newformat
CSeq: 8 INVITE
```

Via: SIP/2.0/UDP 135.180.130.133;branch=z9hG4bKkdjuw  
Content-Type: application/sdp

Johnston, et al.

Informational

[Page 193]

```
v=0
c=IN IP4 135.180.130.88
m=audio 492170 RTP/AVP 0 12
m=video 3227 RTP/AVP 31
a=rtpmap:31 LPC
```

## **[7.6 INVITE with non-SDP message body](#)**

This is a test of a user agent server. It is a request that includes a body of a non-SDP type.

The user agent server should respond with an error.

### Message Details

```
INVITE sip:user@comapny.com SIP/2.0
To: sip:j.user@company.com
From: sip:caller@university.edu;tag=8
Max-Forwards: 70
Call-ID: 0ha0isndaksdj@10.0.0.1
CSeq: 8 INVITE
Via: SIP/2.0/UDP 135.180.130.133;branch=z9hG4bKkdjuw
Content-Type: application/newformat
```

```
<audio>
  <pcmu port="443"/>
</audio>
```

## **[7.7 Unknown Method Message](#)**

This request message contains a new unknown method, NEWMETHOD.

A proxy should forward this using the same retransmission rules as BYE. A UAS should reject it with an error, and list the available methods in the response.

### Message Details

```
NEWMETHOD sip:user@comapny.com SIP/2.0
To: sip:j.user@company.com
From: sip:caller@university.edu;tag=34525
Max-Forwards: 6
Call-ID: 0ha0isndaksdj@10.0.0.1
CSeq: 8 NEWMETHOD
```

Via: SIP/2.0/UDP 135.180.130.133;branch=z9hG4bKkdjuw  
Content-Type: application/sdp

Johnston, et al.

Informational

[Page 194]

```
v=0
o=mhandley 29739 7272939 IN IP4 126.5.4.3
c=IN IP4 135.180.130.88
m=audio 492170 RTP/AVP 0 12
m=video 3227 RTP/AVP 31
a=rtpmap:31 LPC
```

### **7.8 Unknown Method with CSeq Error**

This message is nearly identical to the Unknown Method message. It is a request with a new unknown method, but with a CSeq method tag which does not match.

A proxy should either respond with an error, or correct the method tag. The user agent should reject it with an error, and list the available methods in the response.

#### Message Details

```
NEWMETHOD sip:user@comapny.com SIP/2.0
To: sip:j.user@company.com
From: sip:caller@university.edu;tag=23411413
Max-Forwards: 3
Call-ID: 0ha0isndaksdj@10.0.1.1
CSeq: 8 INVITE
Via: SIP/2.0/UDP 135.180.130.133;branch=z9hG4bKkdjuw
Content-Type: application/sdp
```

```
v=0
o=mhandley 29739 7272939 IN IP4 126.5.4.3
s=-
c=IN IP4 135.180.130.88
t=0 0
m=audio 492170 RTP/AVP 0 12
m=video 3227 RTP/AVP 31
a=rtpmap:31 LPC
```

### **7.9 REGISTER with Unknown Authorization Scheme**

This message is a REGISTER request with an unknown authorization scheme.

The server should do something reasonable, such as rejecting the

request.

Johnston, et al.

Informational

[Page 195]

## Message Details

```
REGISTER sip:company.com SIP/2.0
To: sip:j.user@company.com
From: sip:j.user@company.com;tag=87321hj23128
Max-Forwards: 8
Call-ID: 0ha0isndaksdj@10.0.1.1
CSeq: 8 REGISTER
Via: SIP/2.0/UDP 135.180.130.133;branch=z9hG4bKkdjuw
Authorization: Super-PGP ajsohdaosdh0asyhdaind08yasdknasd09asidhas0d8
```

**7.10 Multiple SIP Request in a Single Message**

This message contains two requests, separated by a bunch of whitespace. Since the message exceeds the length indicated in the Content-Length header, the message should be rejected. (Multiple SIP requests per UDP packet are no longer allowed.)

## Message Details

```
REGISTER sip:company.com SIP/2.0
To: sip:j.user@company.com
From: sip:j.user@company.com;tag=43251j3j324
Max-Forwards: 8
Call-ID: 0ha0isndaksdj@10.0.2.2
Contact: sip:j.user@host.company.com
CSeq: 8 REGISTER
Via: SIP/2.0/UDP 135.180.130.133;branch=z9hG4bKkdjuw
Content-Length: 0
```

```
INVITE sip:joe@company.com SIP/2.0
To: sip:joe@company.com
From: sip:caller@university.edu;tag=141334
Max-Forwards: 8
Call-ID: 0ha0isnda977644900765@10.0.0.1
CSeq: 8 INVITE
Via: SIP/2.0/UDP 135.180.130.133;branch=z9hG4bKkdjuw
Content-Type: application/sdp
```

```
v=0
o=mhandley 29739 7272939 IN IP4 126.5.4.3
s=-
c=IN IP4 135.180.130.88
t=0 0
```

m=audio 492170 RTP/AVP 0 12  
m =video 3227 RTP/AVP 31

Johnston, et al.

Informational

[Page 196]



```
a=rtpmap:31 LPC
```

### **7.11 INVITE missing Required Headers**

This message contains no Call-ID, From, or To header.

The server should not crash, and ideally should respond with an error.

#### Message Details

```
INVITE sip:user@company.com SIP/2.0
CSeq: 0 INVITE
Via: SIP/2.0/UDP 135.180.130.133;branch=z9hG4bKkdjuw
Content-Type: application/sdp
```

```
v=0
o=mhandley 29739 7272939 IN IP4 126.5.4.3
s=-
c=IN IP4 135.180.130.88
t=0 0
m=audio 492170 RTP/AVP 0 12
m=video 3227 RTP/AVP 31
a=rtpmap:31 LPC
```

### **7.12 INVITE with Duplicate Required Headers**

The message contains a request with an extra Call-ID and To field.

The server should not crash, and should ideally respond with an error.

#### Message Details

```
INVITE sip:user@company.com SIP/2.0
Via: SIP/2.0/UDP 135.180.130.133;branch=z9hG4bKkdjuw
Max-Forwards: 70
CSeq: 0 INVITE
Call-ID: 98asdh@10.1.1.1
Call-ID: 98asdh@10.1.1.2
From: sip:caller@university.edu;tag=3413415
From: sip:caller@organization.org
To: sip:user@company.com
Content-Type: application/sdp
```

v=0

Johnston, et al.

Informational

[Page 197]

```
o=mhandley 29739 7272939 IN IP4 126.5.4.3
s=-
c=IN IP4 135.180.130.88
t=0 0
m=audio 492170 RTP/AVP 0 12
m=video 3227 RTP/AVP 31
a=rtpmap:31 LPC
```

### [7.13](#) INVITE with Illegal Expires Header

This message contains an Expires header which has illegal values for a number of components, but otherwise is syntactically correct.

#### Message Details

```
INVITE sip:user@company.com SIP/2.0
Via: SIP/2.0/UDP 135.180.130.133;branch=z9hG4bKkdjuw
Max-Forwards: 88
CSeq: 0 INVITE
Call-ID: 98asdh@10.1.1.2
Expires: Thu, 44 Dec 1999 16:00:00 EDT
From: sip:caller@university.edu;tag=3651
To: sip:user@company.com
Content-Type: application/sdp
```

```
v=0
o=mhandley 29739 7272939 IN IP4 126.5.4.3
s=-
c=IN IP4 135.180.130.88
t=0 0
m=audio 492170 RTP/AVP 0 12
m=video 3227 RTP/AVP 31
a=rtpmap:31 LPC
```

### [7.14](#) 200 OK Response with Broadcast Via Header

This message is a response with a 2nd Via header of 255.255.255.255.

On receiving this response, the top Via header is stripped and the packet forwarded. Since the next address is the broadcast address, it causes the packet to be broadcast onto the network. A smart server should ignore packets with 2nd Via headers that are 255.255.255.255 or 127.0.0.1. At the very least it should not crash.

Message Details

Johnston, et al.

Informational

[Page 198]

```
SIP/2.0 200 OK
Via: SIP/2.0/UDP 135.180.130.57;branch=0
Via: SIP/2.0/UDP 255.255.255.255;branch=0
Max-Forwards: 70
Call-ID: 0384840201@10.1.1.1
CSeq: 0 INVITE
From: sip:user@company.com;tag=11141343
To: sip:user@university.edu;tag=2229
Content-Type: application/sdp
```

```
v=0
o=mhandley 29739 7272939 IN IP4 126.5.4.3
s=-
c=IN IP4 224.2.17.12/127
t=0 0
m=audio 492170 RTP/AVP 0 12
m=video 3227 RTP/AVP 31
a=rtpmap:31 LPC
```

### [7.15](#) INVITE with Invalid Via and Contact Headers

This is a request with the Via and Contact headers incorrect. They contain additional semicolons and commas without parameters or values.

The server should respond with a Bad Request error.

#### Message Details

```
INVITE sip:user@company.com SIP/2.0
To: sip:j.user@company.com
From: sip:caller@university.edu;tag=134161461246
Max-Forwards: 7
Call-ID: 0ha0isndaksdj@10.0.0.1
CSeq: 8 INVITE
Via: SIP/2.0/UDP 135.180.130.133;;;
Contact: "" <>;,"Joe" <sip:joe@org.org>;;;;
Content-Type: application/sdp
```

```
v=0
o=mhandley 29739 7272939 IN IP4 126.5.4.3
s=-
c=IN IP4 135.180.130.88
t=0 0
m=audio 492170 RTP/AVP 0 12
m=video 3227 RTP/AVP 31
a=rtpmap:31 LPC
```



### **7.16 INVITE with Incorrect Content-Length Header**

This is a request message with a Content Length that is much larger than the length of the body.

When sent UDP, the server should respond with an error. With TCP, there's not much you can do but wait...

#### Message Details

```
INVITE sip:user@company.com SIP/2.0
Max-Forwards: 80
To: sip:j.user@company.com
From: sip:caller@university.edu;tag=93942939o2
Call-ID: 0ha0isndaksdj@10.0.0.1
CSeq: 8 INVITE
Via: SIP/2.0/UDP 135.180.130.133
Content-Type: application/sdp
Content-Length: 9999
```

```
v=0
o=mhandley 29739 7272939 IN IP4 126.5.4.3
s=-
c=IN IP4 135.180.130.88
t=0 0
m=audio 492170 RTP/AVP 0 12
m=video 3227 RTP/AVP 31
a=rtpmap:31 LPC
```

### **7.17 INVITE with Invalid Value for Content-Length**

This is a request message with a negative value for Content-Length.

The server should respond with an error.

#### Message Details

```
INVITE sip:user@company.com SIP/2.0
Max-Forwards: 254
To: sip:j.user@company.com
From: sip:caller@university.edu;tag=3
Call-ID: 0ha0isndaksdj@10.0.0.1
CSeq: 8 INVITE
Via: SIP/2.0/UDP 135.180.130.133;branch=z9hG4bKkdjuw
Content-Type: application/sdp
```

Content-Length: -999

Johnston, et al.

Informational

[Page 200]



```
v=0
o=mhandley 29739 7272939 IN IP4 126.5.4.3
s=-
c=IN IP4 135.180.130.88
t=0 0
m=audio 492170 RTP/AVP 0 12
m=video 3227 RTP/AVP 31
a=rtpmap:31 LPC
```

### [7.18](#) INVITE with Garbage after Message Body

This is a request message with garbage after the end of the SDP included in the body.

The servers should reject the request as the body is longer than the Content-Length.

#### Message Details

```
INVITE sip:user@company.com SIP/2.0
To: sip:j.user@company.com
From: sip:caller@university.edu;tag=3223
Max-Forwards: 7
Call-ID: 0ha0isndaksdj@10.0.0.1
CSeq: 8 INVITE
Via: SIP/2.0/UDP 135.180.130.133
Content-Type: application/sdp
Content-Length: 138
```

```
v=0
o=mhandley 29739 7272939 IN IP4 126.5.4.3
s=-
c=IN IP4 135.180.130.88
t=0 0
m=audio 492170 RTP/AVP 0 12
m=video 3227 RTP/AVP 31
a=rtpmap:31 LPC
asdpsd08asdsdk;;;asd
a0sdjhg8a0''...';;;;
```

### [7.19](#) INVITE with Error in Display Name in To Header

This is a request with an unterminated quote in the display name of the To field.

The server can either return an error, or proxy it if it is

Johnston, et al.

Informational

[Page 201]

successful parsing without the terminating quote.

#### Message Details

```
INVITE sip:user@company.com SIP/2.0
To: "Mr. J. User <sip:j.user@company.com>"
From: sip:caller@university.edu;tag=93334
Max-Forwards: 10
Call-ID: 0ha0isndaksdj@10.0.0.1
CSeq: 8 INVITE
Via: SIP/2.0/UDP 135.180.130.133:5050;branch=z9hG4bKkdjuw
Content-Type: application/sdp
Content-Length: 138
```

```
v=0
o=mhandley 29739 7272939 IN IP4 126.5.4.3
s=-
c=IN IP4 135.180.130.88
t=0 0
m=audio 492170 RTP/AVP 0 12
m=video 3227 RTP/AVP 31
a=rtpmap:31 LPC
```

### **7.20 INVITE with a Semicolon-Separated Parameter in the "user" Part**

This is an INVITE request with a semicolon-separated parameter in the "user" part.

Outbound proxies should direct it appropriately.

#### Message Details

```
INVITE sip:user;par=u%40h.com@company.com SIP/2.0
To: sip:j_user@company.com
From: sip:caller@university.edu;tag=33242
Max-Forwards: 3
Call-ID: 0ha0isndaksdj@10.1.1.1
CSeq: 8 INVITE
Via: SIP/2.0/UDP 135.180.130.133;branch=z9hG4bKkdjuw
```

### **7.21 INVITE with Illegal Enclosing of Request-URI in "<>"**

This INVITE is illegal because the Request-URI has been enclosed within in "<>".

An intelligent server may be able to deal with this and fix up

Johnston, et al.

Informational

[Page 202]

athe Request-URI if acting as a Proxy. If not it should respond 400 with an appropriate reason phrase.

#### Message Details

```
INVITE <sip:user@company.com> SIP/2.0
To: sip:user@company.com
From: sip:caller@university.edu;tag=39291
Max-Forwards: 23
Call-ID: 1@10.0.0.1
CSeq: 1 INVITE
Via: SIP/2.0/UDP 135.180.130.133
Content-Type: application/sdp
Content-Length: 174
```

```
v=0
o=mhandley 29739 7272939 IN IP4 126.5.4.3
s=-
c=IN IP4 135.180.130.88
t=3149328700 0
m=audio 492170 RTP/AVP 0 12
m=video 3227 RTP/AVP 31
a=rtpmap:31 LPC
```

### **7.22 INVITE with Illegal LWS within Elements of Request-URI**

This INVITE has illegal LWS within the SIP URI.

An intelligent server may be able to deal with this and fix up the Request-URI if acting as a Proxy. If not it should respond 400 with an appropriate reason phrase.

#### Message Details

```
INVITE sip:user@company.com; transport=udp SIP/2.0
To: sip:user@company.com
From: sip:caller@university.edu;tag=231413434
Max-Forwards: 5
Call-ID: 2@10.0.0.1
CSeq: 1 INVITE
Via: SIP/2.0/UDP 135.180.130.133:5060;branch=z9hG4bKkdjuw
Content-Type: application/sdp
Content-Length: 174
```

```
v=0
o=mhandley 29739 7272939 IN IP4 126.5.4.3
```

S=-

c=IN IP4 135.180.130.88

Johnston, et al.

Informational

[Page 203]

```
t=3149328700 0
m=audio 492170 RTP/AVP 0 12
m=video 3227 RTP/AVP 31
a=rtpmap:31 LPC
```

### **7.23 INVITE with illegal >1 SP between elements of Request URI**

This INVITE has illegal >1 SP between elements of the Request-URI.

An intelligent server may be able to deal with this and fix up the Request-URI if acting as a Proxy. If not it should respond 400 with an appropriate reason phrase.

#### Message Details

```
INVITE sip:user@company.com SIP/2.0
Max-Forwards: 8
To: sip:user@company.com
From: sip:caller@university.edu;tag=8814
Call-ID: 3@10.0.0.1
CSeq: 1 INVITE
Via: SIP/2.0/UDP 135.180.130.133:5060;branch=z9hG4bKkdjuw
Content-Type: application/sdp
Content-Length: 174
```

```
v=0
o=mhandley 29739 7272939 IN IP4 126.5.4.3
s=-
c=IN IP4 135.180.130.88
t=0 0
m=audio 492170 RTP/AVP 0 12
m=video 3227 RTP/AVP 31
a=rtpmap:31 LPC
```

### **7.24 INVITE with a legal SIP URI containing escaped characters**

This INVITE is legal and has a Request-URI with a SIP URI containing escaped characters.

#### Message Details

```
INVITE sip:sip%3Auser%40example.com@company.com;other-param=summit
SIP/2.0
To: sip:user@company.com
```

From: sip:caller@university.edu;tag=938  
Max-Forwards: 87

Johnston, et al.

Informational

[Page 204]



```
Call-ID: 4@10.0.0.1
CSeq: 1 INVITE
Via: SIP/2.0/UDP 135.180.130.133:5060;branch=z9hG4bKkdjuw
Content-Type: application/sdp
Content-Length: 174
```

```
v=0
o=mhandley 29739 7272939 IN IP4 126.5.4.3
s=-
c=IN IP4 135.180.130.88
t=0 0
m=audio 492170 RTP/AVP 0 12
m=video 3227 RTP/AVP 31
a=rtpmap:31 LPC
```

### **7.25 INVITE with the illegal use of escaped headers in Request-URI**

This INVITE is illegal as it the Request-URI contains a SIP URI containing escaped headers.

An intelligent server may be liberal enough to accept this. A server acting as a proxy should remove the escaped header before processing.

#### Message Details

```
INVITE sip:user@company.com?Route=%3Csip:sip.example.com%3E SIP/2.0
To: sip:user@company.com
From: sip:caller@university.edu;tag=341518
Max-Forwards: 7
Call-ID: 5@10.0.0.1
CSeq: 1 INVITE
Via: SIP/2.0/UDP 135.180.130.133:5060;branch=z9hG4bKkdjuw
Content-Type: application/sdp
Content-Length: 174
```

```
v=0
o=mhandley 29739 7272939 IN IP4 126.5.4.3
s=-
c=IN IP4 135.180.130.88
t=0 0
m=audio 492170 RTP/AVP 0 12
m=video 3227 RTP/AVP 31
a=rtpmap:31 LPC
```

## [7.26](#) INVITE containing an unknown scheme in the Request URI

Johnston, et al.

Informational

[Page 205]

This INVITE contains an unknown URI scheme in the Request-URI.

A server should reject this message with a 400 response plus an appropriate reason phrase despite being able to understand the To header as a SIP URI.

#### Message Details

```
INVITE name:user SIP/2.0
To: sip:user@company.com
From: sip:caller@university.edu;tag=384
Max-Forwards: 3
Call-ID: 6@10.0.0.1
CSeq: 1 INVITE
Via: SIP/2.0/UDP 135.180.130.133;branch=z9hG4bKkdjuw
Content-Type: application/sdp
Content-Length: 174
```

```
v=0
o=mhandley 29739 7272939 IN IP4 126.5.4.3
s=-
c=IN IP4 135.180.130.88
t=0 0
m=audio 492170 RTP/AVP 0 12
m=video 3227 RTP/AVP 31
a=rtpmap:31 LPC
```

#### [7.27](#) OPTIONS with no LWS between display name and <

This OPTIONS request is legal despite there being no LWS between the display name and < in the From header.

#### Message Details

```
OPTIONS sip:user@company.com SIP/2.0
To: sip:user@company.com
From: "caller"<sip:caller@example.com>;tag=323
Max-Forwards: 70
Call-ID: 1234abcd@10.0.0.1
CSeq: 1 OPTIONS
Via: SIP/2.0/UDP 135.180.130.133:5060;branch=z9hG4bKkdjuw
```

#### [7.28](#) OPTIONS with extran LWS between display name and <

This OPTIONS request is legal despite there being extra LWS between

the display name and < in the From header.

Johnston, et al.

Informational

[Page 206]

## Message Details

```
OPTIONS sip:user@company.com SIP/2.0
To: sip:user@company.com
From: "caller" <sip:caller@example.com>;tag=32
Max-Forwards: 70
Call-ID: 1234abcd@10.0.0.1
CSeq: 2 OPTIONS
Via: SIP/2.0/UDP 135.180.130.133:5060;branch=z9hG4bKkdjuw
```

**7.29 INVITE with an illegal SIP Date format.**

This INVITE is illegal as it contains a non GMT time zone in the SIP Date header.

An intelligent server may be able to fix this up and correct the time to GMT. Alternatively this message may illicit a 400 response with an appropriate reason phrase.

## Message Details

```
INVITE sip:user@company.com SIP/2.0
To: sip:user@company.com
From: sip:caller@university.edu;tag=2
Max-Forwards: 70
Call-ID: 7@10.0.0.1
CSeq: 1 INVITE
Via: SIP/2.0/UDP 135.180.130.133:5060;branch=z9hG4bKkdjuw
Date: Fri, 01 Jan 2010 16:00:00 EST
Content-Type: application/sdp
Content-Length: 174
```

```
v=0
o=mhandley 29739 7272939 IN IP4 126.5.4.3
s=-
c=IN IP4 135.180.130.88
t=0 0
m=audio 492170 RTP/AVP 0 12
m=video 3227 RTP/AVP 31
a=rtpmap:31 LPC
```

**7.30 INVITE with Passed Expires Time**

This is a legal INVITE but the message content has long since

expired.

Johnston, et al.

Informational

[Page 207]

A server should respond 408 (Timeout).

#### Message Details

```
INVITE sip:user@company.com SIP/2.0
To: sip:user@company.com
From: sip:caller@university.edu;tag=3843
Max-Forwards: 70
Call-ID: 8@10.0.0.1
CSeq: 1 INVITE
Via: SIP/2.0/UDP 135.180.130.133:5060;branch=z9hG4bKkdjuw
Expires: Thu, 01 Dec 1994 16:00:00 GMT
Content-Type: application/sdp
Content-Length: 174
```

```
v=0
o=mhandley 29739 7272939 IN IP4 126.5.4.3
s=-
c=IN IP4 135.180.130.88
t=0 0
m=audio 492170 RTP/AVP 0 12
m=video 3227 RTP/AVP 31
a=rtpmap:31 LPC
```

### **7.31 INVITE with Max-Forwards Set to Zero**

This is a legal SIP request with the Max-Forwards header set to zero.

A proxy or gateway should not forward the request and respond 483 (Too Many Hops).

#### Message Details

```
INVITE sip:user@company.com SIP/2.0
To: sip:user@company.com
From: sip:caller@university.edu;tag=3ghsd41
Call-ID: 9@10.0.0.1
CSeq: 1 INVITE
Via: SIP/2.0/UDP 135.180.130.133:5060;branch=z9hG4bKkdjuw
Max-Forwards: 0
Content-Type: application/sdp
Content-Length: 174
```

```
v=0
o=mhandley 29739 7272939 IN IP4 126.5.4.3
s=-
```

c=IN IP4 135.180.130.88  
t=0 0

Johnston, et al.

Informational

[Page 208]



```
m=audio 492170 RTP/AVP 0 12
m=video 3227 RTP/AVP 31
a=rtpmap:31 LPC
```

### **7.32 REGISTER with a Escaped Header in a Legal SIP URI of a Contact**

This is a legal REGISTER message where the Contact header contains a SIP URI with an escaped header within it.

#### Message Details

```
REGISTER sip:company.com SIP/2.0
To: sip:user@company.com
From: sip:user@company.com;tag=8
Max-Forwards: 70
Contact: sip:user@host.company.com
Call-ID: k345asr13fdbv@10.0.0.1
CSeq: 1 REGISTER
Via: SIP/2.0/UDP 135.180.130.133:5060;branch=z9hG4bKkdjuw
Contact: <sip:user@example.com?Route=%3Csip:sip.example.com%3E>
```

### **7.33 REGISTER with a Escaped Header in a Illegal SIP URI of a Contact**

This is an illegal message as the REGISTER request contains a SIP URI with an escaped header but it is not enclosed in <>

A server should respond 400 with an appropriate reason phrase.

#### Message Details

```
REGISTER sip:company.com SIP/2.0
To: sip:user@company.com
From: sip:user@company.com;tag=998332
Max-Forwards: 70
Contact: sip:user@host.company.com
Call-ID: k345asr13fdbv@10.0.0.1
CSeq: 1 REGISTER
Via: SIP/2.0/UDP 135.180.130.133:5060;branch=z9hG4bKkdjuw
Contact: sip:user@example.com?Route=%3Csip:sip.example.com%3E
```

### **7.34 INVITE with Long Values in Headers**

This is a legal message that contains long values in many headers.

Johnston, et al.

Informational

[Page 209]

## Message Details

INVITE sip:user@company.com SIP/2.0  
To: "I have a user name of extreme proportion"  
<sip:user@company.com:6000;other-param=1234567890somethingelsealong1234567890>  
From: sip:caller@university.edu;tag=12481841982424  
Call-ID:  
kl24ahsd546folnyt2vbak9sad98u23naodiunzds09a3bqw0sdfbsk34poouymnae004  
3nsed09mfkvc74bd0cuwnms05dknw87hjpobd76f  
CSeq: 1 INVITE  
P-My-State: sldkjflzdsfaret0803adgaasd0afds0asdaasd  
Via: SIP/2.0/TCP sip33.example.com  
Via: SIP/2.0/TCP sip32.example.com  
Via: SIP/2.0/TCP sip31.example.com  
Via: SIP/2.0/TCP sip30.example.com  
Via: SIP/2.0/TCP sip29.example.com  
Via: SIP/2.0/TCP sip28.example.com  
Via: SIP/2.0/TCP sip27.example.com  
Via: SIP/2.0/TCP sip26.example.com  
Via: SIP/2.0/TCP sip25.example.com  
Via: SIP/2.0/TCP sip24.example.com  
Via: SIP/2.0/TCP sip23.example.com  
Via: SIP/2.0/TCP sip22.example.com  
Via: SIP/2.0/TCP sip21.example.com  
Via: SIP/2.0/TCP sip20.example.com  
Via: SIP/2.0/TCP sip19.example.com  
Via: SIP/2.0/TCP sip18.example.com  
Via: SIP/2.0/TCP sip17.example.com  
Via: SIP/2.0/TCP sip16.example.com  
Via: SIP/2.0/TCP sip15.example.com  
Via: SIP/2.0/TCP sip14.example.com  
Via: SIP/2.0/TCP sip13.example.com  
Via: SIP/2.0/TCP sip12.example.com  
Via: SIP/2.0/TCP sip11.example.com  
Via: SIP/2.0/TCP sip10.example.com  
Via: SIP/2.0/TCP sip9.example.com  
Via: SIP/2.0/TCP sip8.example.com  
Via: SIP/2.0/TCP sip7.example.com  
Via: SIP/2.0/TCP sip6.example.com  
Via: SIP/2.0/TCP sip5.example.com  
Via: SIP/2.0/TCP sip4.example.com  
Via: SIP/2.0/TCP sip3.example.com  
Via: SIP/2.0/TCP sip2.example.com  
Via: SIP/2.0/TCP sip1.example.com  
Via: SIP/2.0/TCP  
host.example.com;received=135.180.130.133;branch=C1C3344E2710000000E2

99E568E7potato10potato0potato0  
Content-Type: application/sdp

Johnston, et al.

Informational

[Page 210]

```

v=0
o=mhandley 29739 7272939 IN IP4 126.5.4.3
s=-
c=IN IP4 135.180.130.88
t=0 0
m=audio 492170 RTP/AVP 0 12
m=video 3227 RTP/AVP 31
a=rtpmap:31 LPC

```

### **7.35 OPTIONS with multiple headers.**

This is an illegal and badly mangled message.

A server should respond 400 with an appropriate reason phrase if it can. It may just drop this message.

#### Message Details

```

OPTIONS sip:135.180.130.133 SIP/2.0
Via: SIP/2.0/UDP company.com:5604
Max-Forwards: 70
From: sip:iuser@company.com;tag=74345345
To: sip:user@135.180.130.133
Call-ID: 1804928587@company.com
CSeq: 1 OPTIONS
Expires: 0 0l@company.com
To: sip:user@135.180.130.133
Call-ID: 1804928587@company.com
CSeq: 1 OPTIONS
Contact: sip:host.company.com
Expires: 0xpires: 0sip:host.company.com
Expires: 0
Contact: sip:host.company.com

```

### **7.36 INVITE with large number of SDP attributes and telephone subscriber Request-URI**

This is a legal message with a large number of SDP attributes and a long telephone subscriber Request-URI

#### Message Details

```

INVITE sip:+19725552222;phone-
context=name%40domain;new=user?%22Route%3a%20X%40Y%3bZ=W%22@gw1.atlan

```

ta.com;user=phone SIP/2.0

Via: SIP/2.0/UDP iftgw.biloxi.com:5060;branch=z9hG4bKjeefr3

Johnston, et al.

Informational

[Page 211]

```
Max-Forwards: 70
From:
<sip:+13035551111@ift.client.atlanta.com;user=phone>;tag=3321flke
To: sip:+16555552222@ss1.atlanta.com;user=phone
Call-ID: 1717@ift.client.atlanta.com
CSeq: 56 INVITE
Content-Type: application/sdp
Content-Length: 320
```

```
v=0
o=faxgw1 2890844527 2890844527 IN IP4 iftgw.biloxi.com
s=-
c=IN IP4 iftmg.biloxi.com
t=0 0
m=image 49172 udptl t38
a=T38FaxVersion:0
a=T38maxBitRate:14400
a=T38FaxFillBitRemoval:0
a=T38FaxTranscodingMMR:0
a=T38FaxTranscodingJBIG:0
a=T38FaxRateManagement:transferredTCF
a=T38FaxMaxBuffer:260
a=T38FaxUdpEC:t38UDPR
```

### **7.37 REGISTER with a contact parameter.**

This REGISTER contains a contact where the 'user' parameter should be interpreted as being a contact-param and not a url-param.

The register should succeed but a subsequent retrieval of the registration must not include "user=phone" as a url-parameter.

#### Message Details

```
REGISTER sip:bell-tel.com SIP/2.0
Via: SIP/2.0/UDP saturn.bell-tel.com:5060;branch=z9hG4bKkdjuw
Max-Forwards: 70
From: sip:watson@bell-tel.com;tag=DkfVgjkrtMwaerKKpe
To: sip:watson@bell-tel.com
Call-ID: 70710@saturn.bell-tel.com
CSeq: 2 REGISTER
Contact: sip:+19725552222@gw1.atlanta.com;user=phone
```

### **7.38 REGISTER with a url parameter.**

This register contains a contact where the 'user'parameter is a url-

param.

Johnston, et al.

Informational

[Page 212]



The register should succeed and a subsequent retrieval of the registration must include "user=phone" as a url-parameter.

#### Message Details

```
REGISTER sip:bell-tel.com SIP/2.0
Via: SIP/2.0/UDP saturn.bell-tel.com:5060;branch=z9hG4bKkdjuw
Max-Forwards: 70
From: sip:watson@bell-tel.com;tag=838293
To: sip:watson@bell-tel.com
Call-ID: 70710@saturn.bell-tel.com
CSeq: 3 REGISTER
Contact: <sip:+19725552222@gw1.atlanta.com;user=phone>
```

### **7.39 INVITE with an Unquoted Display Name Containing Multiple Tokens**

This is a legal INVITE where the To and From header contain display names that contain multiple tokens but are unquoted.

#### Message Details

```
INVITE sip:t.watson@ieee.org SIP/2.0
Via: SIP/2.0/UDP c.bell-tel.com:5060;branch=z9hG4bKkdjuw
Max-Forwards: 70
From: A. Bell <sip:a.g.bell@bell-tel.com>;tag=459843
To: T. Watson <sip:t.watson@ieee.org>
Call-ID: 31414@c.bell-tel.com
CSeq: 1 INVITE
```

### **7.40 INVITE with an Unquoted Display Name Containing Non-Token Characters**

This is an illegal invite as the display names in the To and From headers contain non-token characters but are unquoted.

A server may be intelligent enough to cope with this but may also return a 400 response with an appropriate reason phrase.

#### Message Details

```
INVITE sip:t.watson@ieee.org SIP/2.0
Via: SIP/2.0/UDP c.bell-tel.com:5060;branch=z9hG4bKkdjuw
Max-Forwards: 70
From: Bell, Alexander <sip:a.g.bell@bell-tel.com>;tag=43
```

To: Watson, Thomas <sip:t.watson@ieee.org>  
Call-ID: 31415@c.bell-tel.com

Johnston, et al.

Informational

[Page 213]

CSeq: 1 INVITE

#### **[7.41](#) INVITE with Unknown (Higher) Protocol Version in Start Line**

This is an illegal INVITE as the SIP Protocol version is unknown.

The server should respond to the request with a bad version error.

##### Message Details

```
INVITE sip:t.watson@ieee.org SIP/7.0
Via: SIP/2.0/UDP c.bell-tel.com;branch=z9hG4bKkdjuw
Max-Forwards: 70
From: A. Bell <sip:a.g.bell@bell-tel.com>;tag=qweoiqpe
To: T. Watson <sip:t.watson@ieee.org>
Call-ID: 31417@c.bell-tel.com
CSeq: 1 INVITE
```

#### **[7.42](#) INVITE with [RFC2543](#) syntax**

This is a legal message per [RFC 2543](#) which should be accepted by [RFC 3261](#) elements which want to maintain backwards compatibility.

##### Message Details

```
INVITE sip:UserB@biloxi.com SIP/2.0
Via: SIP/2.0/UDP iftgw.biloxi.com
From: <sip:+13035551111@ift.client.atlanta.com;user=phone>;tag=93752
Record-Route: <sip:UserB@biloxi.com;maddr=ss1.wcom.com>
To: sip:+16505552222@ss1.atlanta.com;user=phone
Call-ID: 1717@ift.client.atlanta.com
CSeq: 56 INVITE
```

## **[8](#) Security Considerations**

Since this document represents NON NORMATIVE examples of SIP session establishment and interworking between SIP and the PSTN, the security considerations in [RFC 3261](#) [[RFC3261](#)] and [[SIP-ISUP](#)] apply.

## **[9](#) IANA Considerations**

None.



## **10 Acknowledgements**

Thanks to Rohan Mahy, Adam Roach, Gonzalo Camarillo, Cullen Jennings, and Tom Taylor for their detailed comments during the final final review.

The authors wish to thank Neil Deason for his additions to the Torture Test messages and Kundan Singh for performing parser validation of messages.

The authors wish to thank the following individuals for their participation in the final review of this call flows document: Aseem Agarwal, Rafi Assadi, Ben Campbell, Sunitha Kumar, Jon Peterson, Marc Petit-Huguenin, Vidhi Rastogi, and Bodgey Yin Shaohua.

The authors also wish to thank the following individuals for their assistance: Jean-Francois Mule, Hemant Agrawal, Henry Sinnreich, David Devanatham, Joe Pizzimenti, Matt Cannon, John Hearty, the whole MCI WorldCom IPOP Design team, Scott Orton, Greg Osterhout, Pat Sollee, Doug Weisenberg, Danny Mistry, Steve McKinnon, and Denise Ingram, Denise Caballero, Tom Redman, Ilya Slain, Pat Sollee, John Truetken, and others from MCI WorldCom, 3Com, Cisco, Lucent and Nortel.

## **11 References**

[RFC3261] J. Rosenberg, H. Schulzrinne, G. Camarillo, A. Johnston, J. Peterson, R. Sparks, M. Handley, and E. Schooler, "SIP: Session Initiation Protocol", Internet Engineering Task Force, Work in Progress.

[RFC2617] Franks, J., Hallam-Baker, P., Hostetler, J., Lawrence, S., Leach, P., Luotonen, A. and L. Stewart, "HTTP authentication: Basic and Digest Access Authentication", [RFC 2617](#), June 1999.

[RFC3264] J. Rosenberg and H. Schulzrinne, "An Offer/Answer Model with SDP", Internet Engineering Task Force, [RFC 3264](#), April 2002.

[RFC2401] S. Kent, R. Atkinson, "Security Architecture for the Internet Protocol", [RFC 2401](#), November 1998.

[RFC2246] Dierks, T. and C. Allen, "The TLS Protocol Version 1.0", [RFC 2246](#), January 1999.

[RFC2806] A. Vaha-Sipila, "URLs for Telephone Calls", Internet Draft, Internet Engineering Task Force, [RFC 2806](#), April 2000.

[SIP-ISUP] G. Camarillo, "Best Current Practice for ISUP to SIP

Mapping", Internet Draft, Internet Engineering Task Force,  
Work in progress.

Johnston, et al.

Informational

[Page 215]

Author's Addresses

All listed authors actively contributed large amounts of text to this document.

Alan Johnston  
WorldCom  
100 South 4th Street  
St. Louis, MO 63102  
USA

E-Mail: alan.johnston@wcom.com

Steve Donovan  
dynamicsoft, Inc.  
5100 Tennyson Parkway  
Suite 1200  
Plano, Texas 75024  
USA

E-Mail: sdonovan@dynamicsoft.com

Robert Sparks  
dynamicsoft, Inc.  
5100 Tennyson Parkway  
Suite 1200  
Plano, Texas 75024  
USA

E-Mail: rsparks@dynamicsoft.com

Chris Cunningham  
dynamicsoft, Inc.  
5100 Tennyson Parkway  
Suite 1200  
Plano, Texas 75024  
USA

E-Mail: ccunningham@dynamicsoft.com

Dean Willis  
dynamicsoft, Inc.  
5100 Tennyson Parkway  
Suite 1200  
Plano, Texas 75024  
USA

Email: [dwillis@dynamicsoft.com](mailto:dwillis@dynamicsoft.com)

Johnston, et al.

Informational

[Page 216]



Jonathan Rosenberg  
dynamicsoft  
72 Eagle Rock Ave  
East Hanover, NJ 07936  
USA

Email: [jdrosen@dynamicsoft.com](mailto:jdrosen@dynamicsoft.com)

Kevin Summers  
Sonus  
1701 North Collins Blvd, Suite 3000  
Richardson, TX 75080  
USA

Email: [kevin.summers@sonusnet.com](mailto:kevin.summers@sonusnet.com)

Henning Schulzrinne  
Dept. of Computer Science  
Columbia University  
1214 Amsterdam Avenue  
New York, NY 10027  
USA

Email: [schulzrinne@cs.columbia.edu](mailto:schulzrinne@cs.columbia.edu)

#### Copyright Notice

"Copyright (C) The Internet Society 2002. All Rights Reserved.

This document and translations of it may be copied and furnished to others, and derivative works that comment on or otherwise explain it or assist in its implementation may be prepared, copied, published and distributed, in whole or in part, without restriction of any kind, provided that the above copyright notice and this paragraph are included on all such copies and derivative works. However, this document itself may not be modified in any way, such as by removing the copyright notice or references to the Internet Society or other Internet organizations, except as needed for the purpose of developing Internet standards in which case the procedures for copyrights defined in the Internet Standards process must be followed, or as required to translate it into languages other than

English.

Johnston, et al.

Informational

[Page 217]

The limited permissions granted above are perpetual and will not be revoked by the Internet Society or its successors or assigns.

This document and the information contained herein is provided on an "AS IS" basis and THE INTERNET SOCIETY AND THE INTERNET ENGINEERING TASK FORCE DISCLAIMS ALL WARRANTIES, EXPRESS OR IMPLIED, INCLUDING BUT NOT LIMITED TO ANY WARRANTY THAT THE USE OF THE INFORMATION HEREIN WILL NOT INFRINGE ANY RIGHTS OR ANY IMPLIED WARRANTIES OF MERCHANTABILITY OR FITNESS FOR A PARTICULAR PURPOSE.

#### Acknowledgement

Funding for the RFC Editor function is currently provided by the Internet Society.

