

SIPREC
Internet-Draft
Intended status: Standards Track
Expires: October 15, 2011

Ram Mohan. Ravindranath
Parthasarathi. Ravindran
Paul. Kyzivat
Cisco Systems, Inc.
April 13, 2011

Session Initiation Protocol (SIP) Recording Metadata
draft-ietf-siprec-metadata-00

Abstract

Session recording is a critical requirement in many communications environments such as call centers and financial trading. In some of these environments, all calls must be recorded for regulatory, compliance, and consumer protection reasons. Recording of a session is typically performed by sending a copy of a media stream to a recording device. This document describes the metadata model as viewed by Session Recording Server(SRS).

Status of this Memo

This Internet-Draft is submitted in full conformance with the provisions of [BCP 78](#) and [BCP 79](#).

Internet-Drafts are working documents of the Internet Engineering Task Force (IETF). Note that other groups may also distribute working documents as Internet-Drafts. The list of current Internet-Drafts is at <http://datatracker.ietf.org/drafts/current/>.

Internet-Drafts are draft documents valid for a maximum of six months and may be updated, replaced, or obsoleted by other documents at any time. It is inappropriate to use Internet-Drafts as reference material or to cite them other than as "work in progress."

This Internet-Draft will expire on October 15, 2011.

Copyright Notice

Copyright (c) 2011 IETF Trust and the persons identified as the document authors. All rights reserved.

This document is subject to [BCP 78](#) and the IETF Trust's Legal Provisions Relating to IETF Documents (<http://trustee.ietf.org/license-info>) in effect on the date of publication of this document. Please review these documents carefully, as they describe your rights and restrictions with respect to this document. Code Components extracted from this document must

Internet-Draft

SIP Recording Metadata

April 2011

include Simplified BSD License text as described in Section 4.e of the Trust Legal Provisions and are provided without warranty as described in the Simplified BSD License.

Table of Contents

1.	Introduction	3
2.	Terminology	3
3.	Metadata Model	3
4.	Recording Metadata elements	5
4.1.	Recording Session	5
4.1.1.	Attributes	5
4.1.2.	Associations	6
4.2.	Communication Session Group	6
4.2.1.	Attributes	6
4.2.2.	Associations	6
4.3.	Communication Session	7
4.3.1.	Attributes	7
4.3.2.	Associations	8
4.4.	Participant	8
4.4.1.	Attributes	9
4.4.2.	Associations	9
4.5.	Media Stream	10
4.5.1.	Attributes	10
4.5.2.	Associations	11
4.6.	Extension Data	11
5.	Metadata Model Object Instances	11
5.1.	Use case 1: Basic Call	11
5.2.	Use case 2: Basic Call with hold/resume	12
5.3.	Use case 3: Basic call with Transfer	14
5.4.	Conference Use Cases	15
5.4.1.	Case 1:	16
5.4.2.	Case 2:	18
5.4.3.	Case 3:	20
5.4.4.	Case 4:	21
6.	Security Considerations	22
7.	IANA Considerations	22
8.	Acknowledgement	22
9.	References	22
9.1.	Normative References	22
9.2.	Informative References	22
	Authors' Addresses	22

1. Introduction

Session recording is a critical requirement in many communications environments such as call centers and financial trading. In some of these environments, all calls must be recorded for regulatory, compliance, and consumer protection reasons. Recording of a session is typically performed by sending a copy of a media stream to a recording device. This document focuses on the Recording metadata which describes the communication session. The document describes a metadata model as viewed by Session Recording Server, the requirements for which are described in [[I-D.ietf-siprec-req](#)] and the architecture for which is described in [[I-D.ietf-siprec-architecture](#)].

2. Terminology

The key words "MUST", "MUST NOT", "REQUIRED", "SHALL", "SHALL NOT", "SHOULD", "SHOULD NOT", "RECOMMENDED", "MAY", and "OPTIONAL" in this document are to be interpreted as described in [[RFC2119](#)]. This document only uses these key words when referencing normative statements in existing RFCs."

3. Metadata Model

Metadata is the information that describes recorded media and the CS to which they relate. Below diagram shows a model for Metadata as viewed by Session Recording Server (SRS).

Internet-Draft

SIP Recording Metadata

April 2011

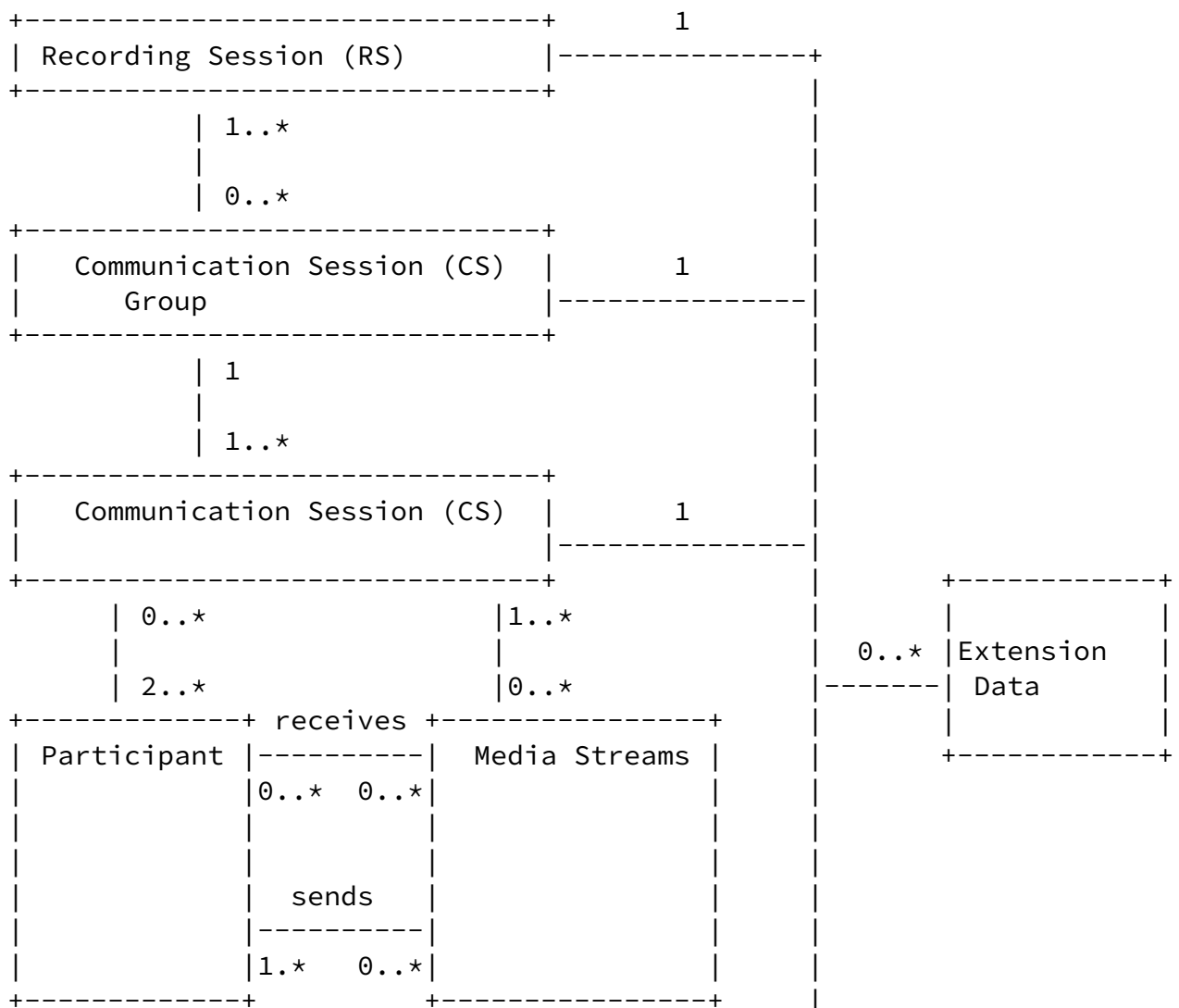

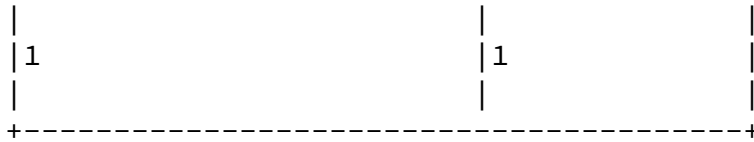

The mechanism MUST provide a means to convey every attribute mentioned in the metadata model. Session Recording Client (SRC) MAY initiate the Recording Session. It should be noted that the Recording Session is a completely independent from the Communication Session that is being recorded at both the SIP dialog level and at the session level. The metadata MUST be conveyed from SRC to SRS. The metadata MAY be conveyed within the Recording Session Dialog.

Note that the metadata model captures changes that occur over the duration of the recording session. For example, if the call is transferred from one participant to another, then the SRC SHALL

convey a change of participant and the properties of the new media stream to the SRS.

Some of the data in the model may not be conveyed explicitly from the SRC to the SRS, if it can be obtained contextually by the SRS. For instance, the timing of changes may not explicitly conveyed from the SRC to the SRC, because the mechanism (yet to be defined) which conveys the metadata may implicitly provide the timing. (E.g. the time a change occurred by be assumed to be the same as the time when notification of the change is received by the SRS.)

[4.](#) Recording Metadata elements

This section describes each element of the metadata model, and the attributes of each element. This section also describes how different elements are associated.

[4.1.](#) Recording Session

+-----+

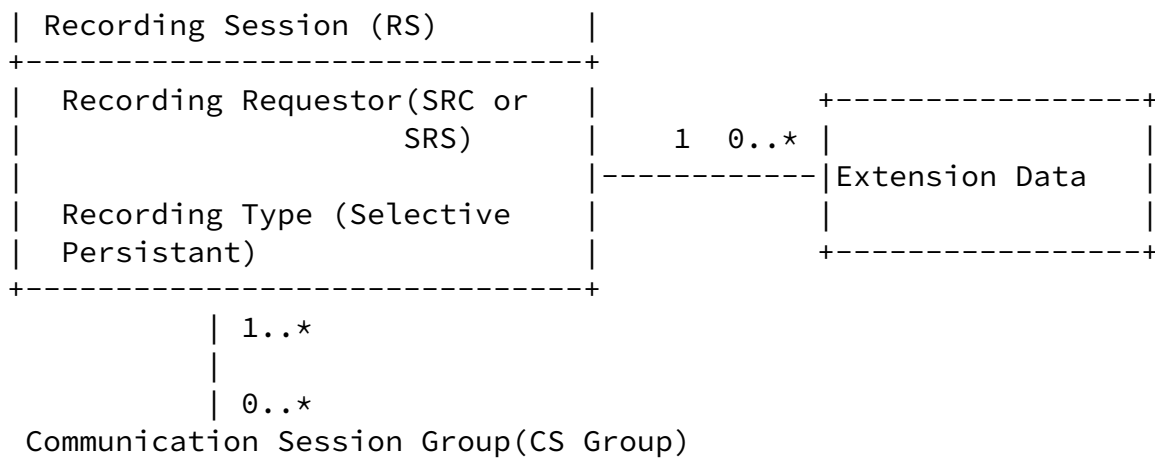

A Recording Session element represents one instance of a Recording Session.

4.1.1. Attributes

A Recording Session element MAY have attributes like:

- o Recording requestor(which could be SRS or SRC).
- o Recording type - This attribute indicates whether the recording session is selective or persistent.

4.1.2. Associations

One instance of Recording Session SHALL have:

- o Zero or more instances of Communication Session Group.The allowance of zero instances is to accommodate persistent recording, where there may be none.
- o Each CS Group MUST be associated with one or more Recording Sessions [setup by the same SRC.]

4.2. Communication Session Group

Recording Session (RS)
| 1..*

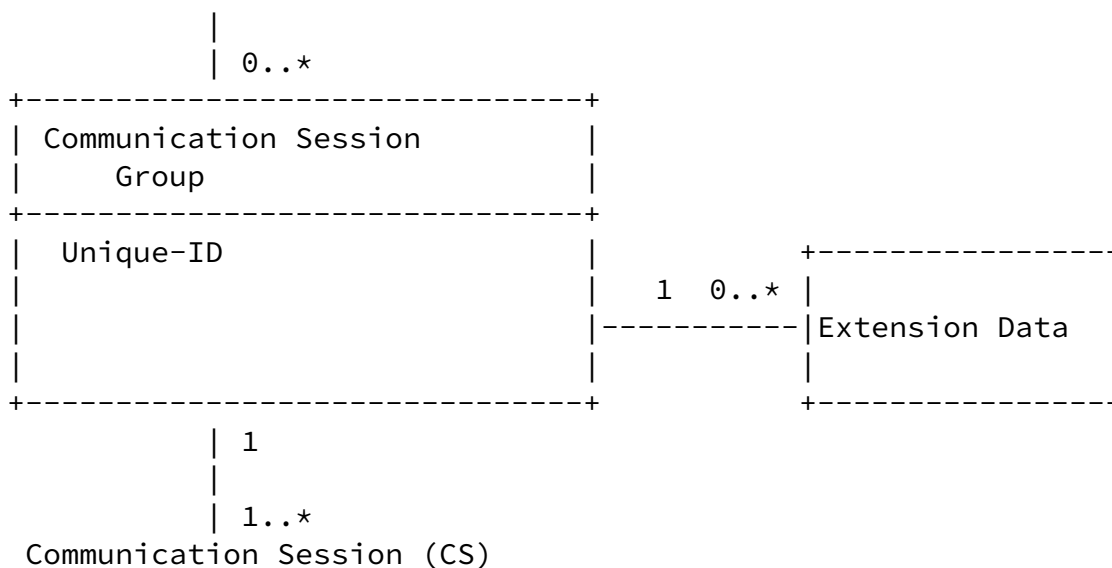

A Communication Session Group provides association or linking of Communication Sessions.

4.2.1. Attributes

A CS Group MUST have a Unique-ID attribute. This Unique-ID is to group different CSs that are related. SRC (or MAY be SRS) MUST ensure the uniqueness of Unique-ID in case multiple SRC interacts with the same SRS. The mechanism by which SRC groups the CS is outside the scope of SIPREC.

4.2.2. Associations

A communication Session Group SHALL be associated with RS and CS in the following manner:

- o There can be one or more Recording Session elements per Communication Session Group.
- o Each Communication Session Group MUST be associated with one or more RS [setup by the same SRC]
- o There MAY be one or more Communication Sessions per CS Group [e.g. Consult Transfer]
- o Each CS MUST be associated to one CS-Group

4.3. Communication Session

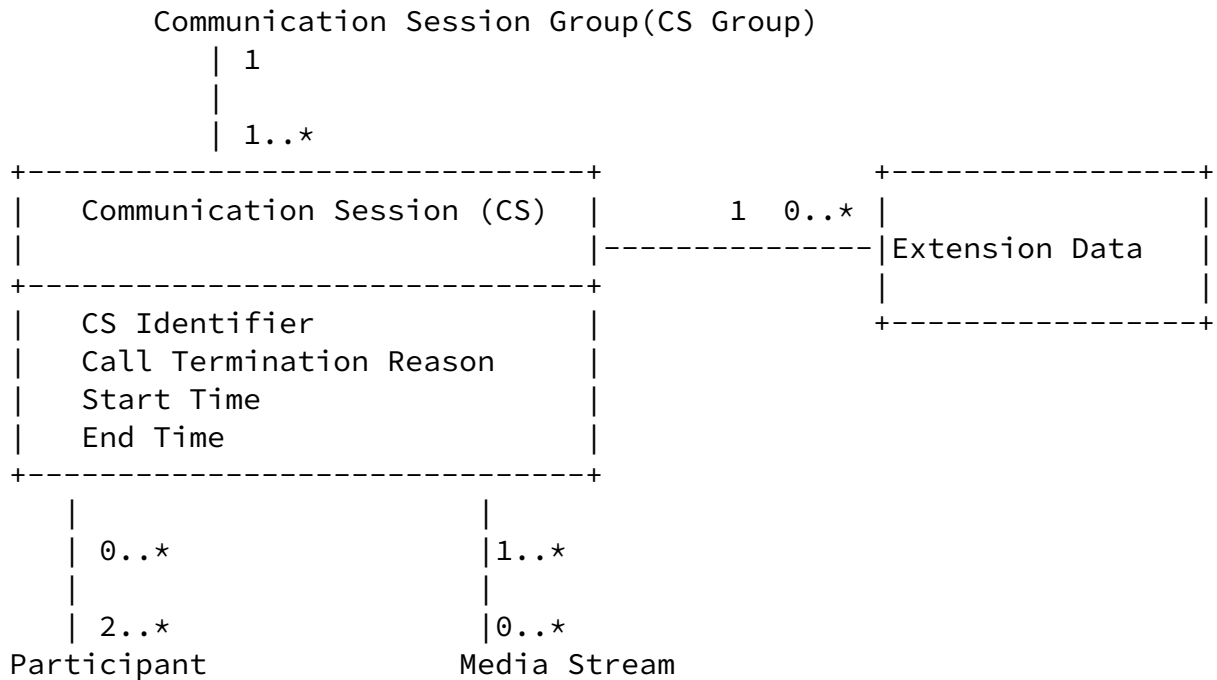

A Communication Session block/element in the metadata model represents Communication Session and its properties needed as seen by SRC.

4.3.1. Attributes

A communication Session block SHALL have the following attributes:

- o Call Termination Reason - This represents the reason why a CS was terminated. The communication session MAY contain a Call Termination Reason. This MAY be derived from SIP Reason header of CS.
- o CS Identifier - This attribute is used to uniquely identify a CS.

- o Start Time - This attribute represents CS start time

- o End Time - This attribute represents CS end time

Attributes like Retention (represent the value/duration for which Media streams of the CS needs to be retained), Force Deletion, Access Information e.t.c that are primarily related to policy will not be passed in metadata from SRC to SRS. However if there are implementations where SRC has enough information, this could be sent as Extension Data attached to CS

4.3.2. Associations

A Communication Session SHALL be associated to CS-Group, Participant and Media Stream. Cardinalities between CS and Participant allows:

- o CS to have atleast two or more participants
- o Participant may be associated with zero or more CS's (It is possible, though unlikely, that there are participants who are not part of any CS). An example of such a case is participants in a premixed media stream. The SRC may have knowledge of such Participants, yet not have any signaling relationship with them. This might arise if one participant in CS is a conf focus. Another use case is if one UA in CS works in 3pcc mode to acquire an MoH media stream, this might be reflected as unique source for media stream without having a reported signaling relationship to it.
- o The model also allows participants in CS that are not participants in the media. An example is the identity of a 3pcc controller that has initiated a CS to two or more participants of the CS. Another example is the identity of a conference focus. Of course a focus is probably in the media, but since it may only be there as a mixer, it may not report itself as a participant in any of the media streams.

Cardinalities between CS and Media Stream allows:

- o A CS to have zero or more Streams
- o A stream can be associated with 1 or more CS. An example is multicast MoH stream which might be associated with many CSs. Also if we were to consider a B2BUA to have a separate CS on each "side" then they might share a stream. (Though more likely this would be treated as a single CS.)

4.4. Participant

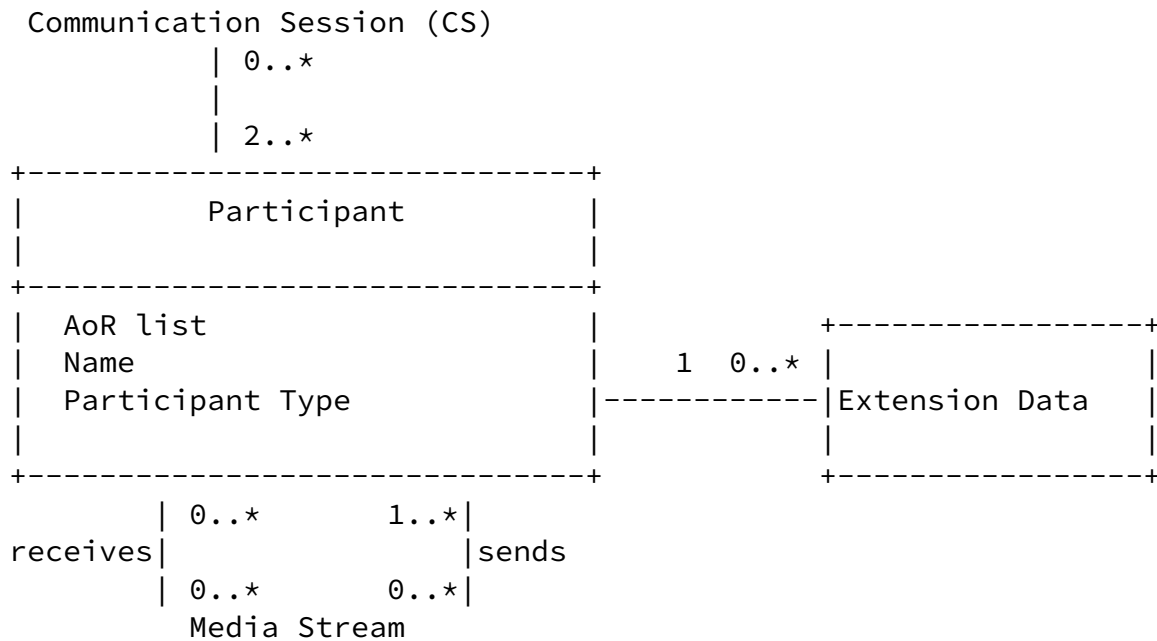

A Participant block has information about a device that is part of a CS and/or contributes/consumes media stream(s) belonging to a CS.

[4.4.1. Attributes](#)

Participant has attributes like:

- o AoR list - Has list of AoRs. An AoR MAY be SIP/SIPS/TEL URI. There MAY be cases where a participant can have more than one AoR [e.g. P-Asserted-ID which can have both SIP and TEL URIs]
- o Name - This attribute represents Participant name(SIP display name) or DN number (in case it is known)
- o Participant Type - This attribute can have values as "internal" or "external" or "don't know" (in cases where it is not possible to determine).

Other attributes [like Participant Role] MAY be carried as part of extension data to Participant from SRC to SRS.

[4.4.2. Associations](#)

Cardinalities between participant and Media Stream allows:

- o Participant to receives zero or more media streams
- o Participant to send zero or more media streams. (Same participant provides multiple streams e.g. audio and video)

- o Media stream to be received by zero or more participants. Its possible, though perhaps unlikely, that a stream is generated but sent only to the SRC and SRS, not to any participant. E.g. In conferencing where all participants are on hold and the SRC is collocated with the focus. Also a media stream may be received by multiple participants (e.g. Whisper calls, side conversations).
- o Media stream to be sent by one or more participants (pre-mixed streams).

Example of a case where a participant may receive Zero or more streams - a Supervisor may have side conversation with Agent, while Agent converses with customer.

[4.5. Media Stream](#)

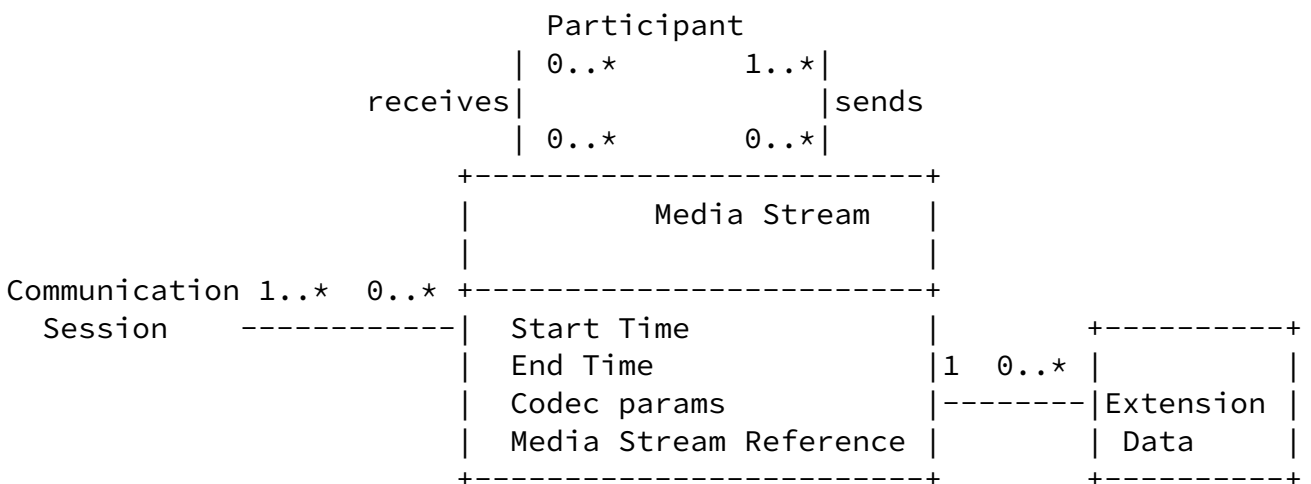

A Media Stream block shall have properties of media as seen by SRC and sent to SRS. Different instances of Media Stream block would be created whenever there is a change in media (e.g. dir change like pause/resume and/or codec change and/or participant change.).

[4.5.1. Attributes](#)

A Media Stream block SHALL have the following attributes:

- o Start Time - Represents Media Start time at SRC.
- o End Time - Represents Media End time at SRC. This is an optional attribute and MAY be included after a stream ends
- o Codec params - represents codec parameters of the CS media
- o Media Stream Reference - In implementations this can reference to m-line

The metadata model should include media streams that are not being

delivered to the SRS. Examples include cases where SRC offered certain media types but SRS chooses to accept only a subset of them OR an SRC may not even offer a certain media type due to its restrictions to record

[4.5.2.](#) Associations

A Media Stream SHALL be associated with Participant and CS. The details of association with the Participant are described in the Participant block section. The details of association with CS is mentioned in the CS section.

[4.6.](#) Extension Data

A recording metadata object contains additional data not specified as part of siprec. This is intended to accommodate future standards track extensions, as well as vendor and user specific extensions. The mechanism MUST provide a means of unambiguously distinguishing such extension data.

[5.](#) Metadata Model Object Instances

This section describes the metadata model object instances for different use cases of SIPREC. For the sake of simplicity as the media streams sent by each of the participants is received by every other participant in these use cases, it is NOT shown in the object instance diagrams below.

[5.1.](#) Use case 1: Basic Call

Basic call between two Participants A and B. In this use case each

participant sends one Media Stream. For the sake of simplicity "receives" lines are not shown in this instance diagram. Media Streams sent by each participant is received all other participants of that CS.

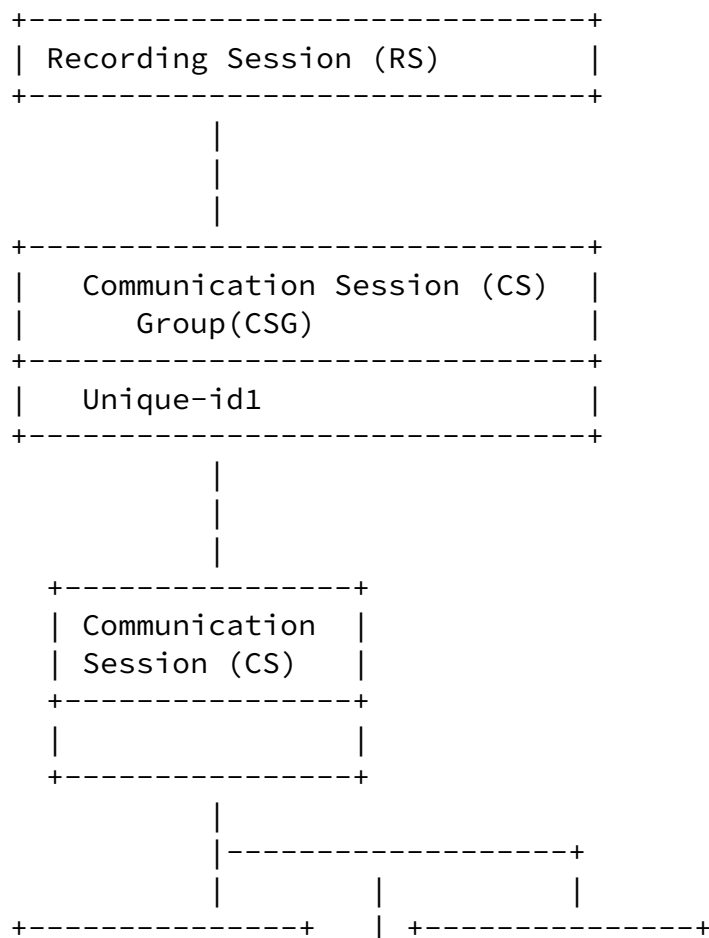

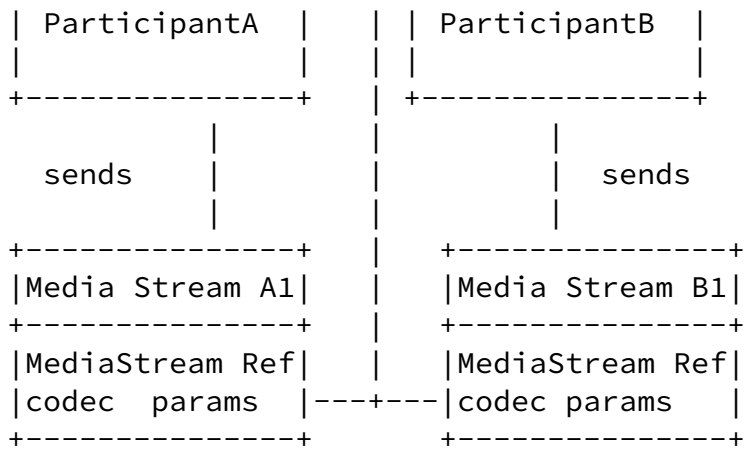

[5.2.](#) Use case 2: Basic Call with hold/resume

Basic call between two Participants A and B and with Participant A or B doing a Hold/Resume. In this use case each participant sends one Media Stream. After Hold/Resume the properties of Media MAY change. For the sake of simplicity "receives" lines are not shown in this instance diagram. Media Streams sent by each participant is received all other participants of that CS.

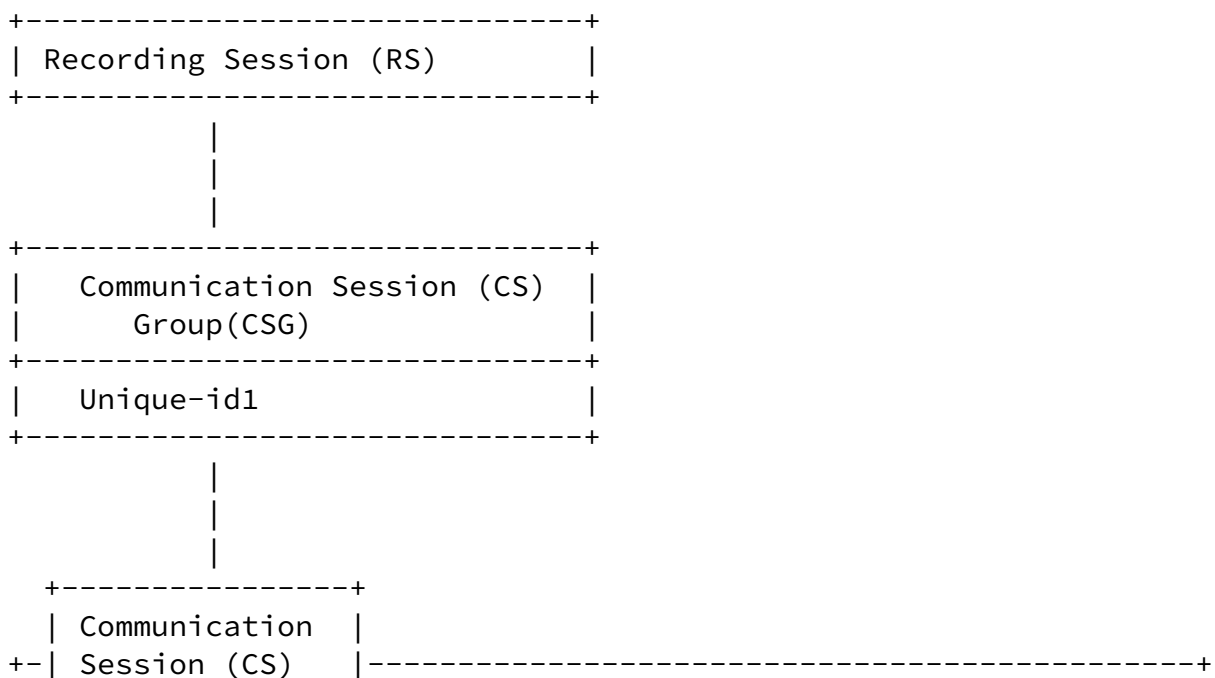

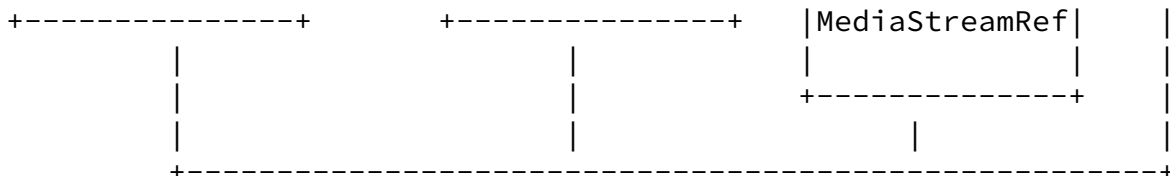
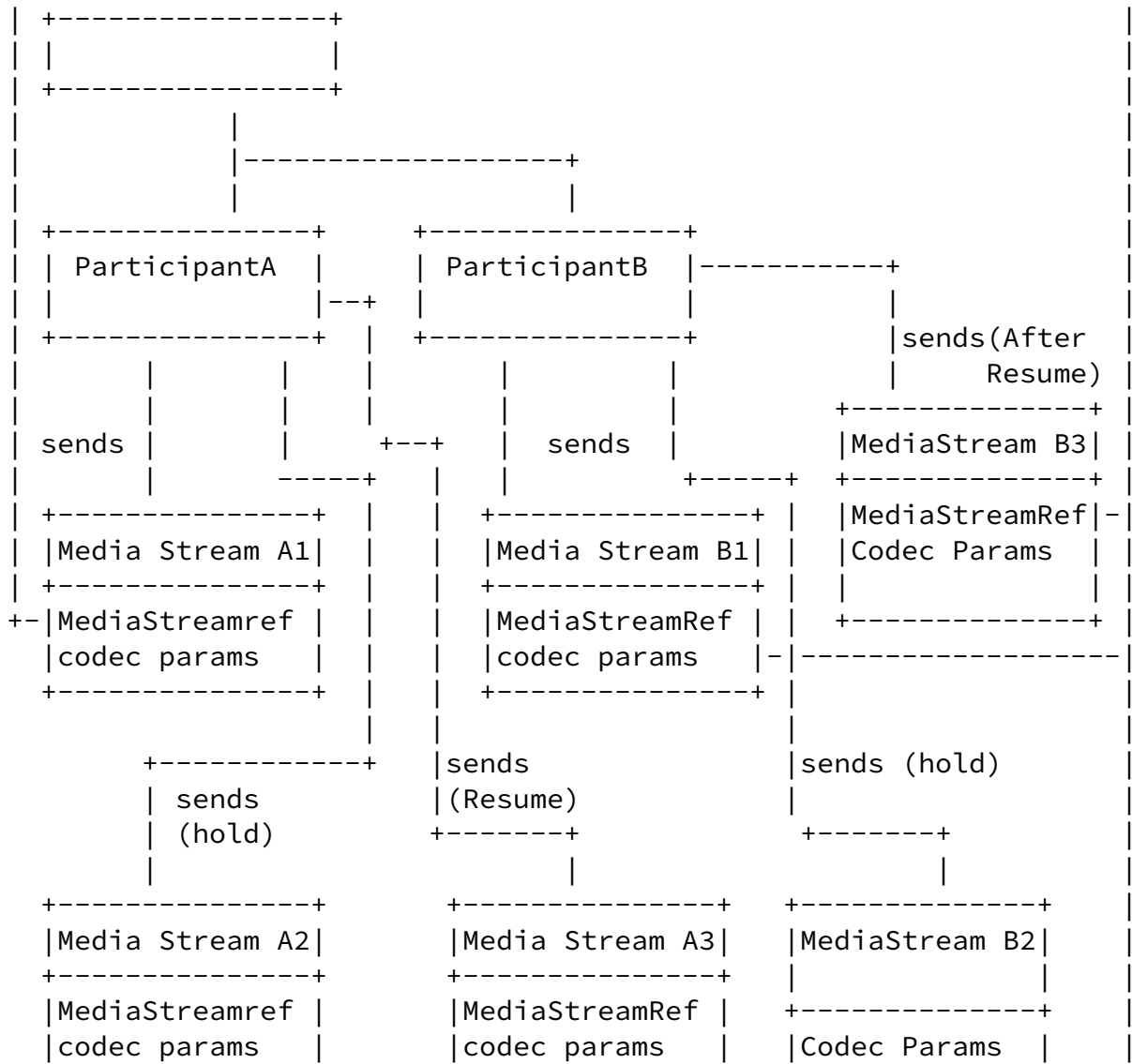

NOTE: Need discussions on how to represent Hold/Resume from SRC to SRS and Pause/Resume from SRS to SRC.

[5.3.](#) Use case 3: Basic call with Transfer

Basic call between two Participants A and B and with Participant A transfer(consult transfer) to Participant C. In this use case each participant sends one Media Stream. After transfer the properties of Participant A Media MAY change. For the sake of simplicity "receives" lines are not shown in this instance diagram. Media Streams sent by each participant is received all other participants of that CS.

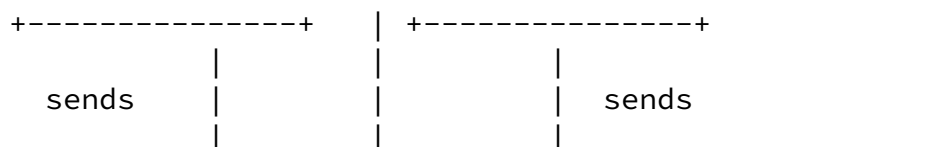
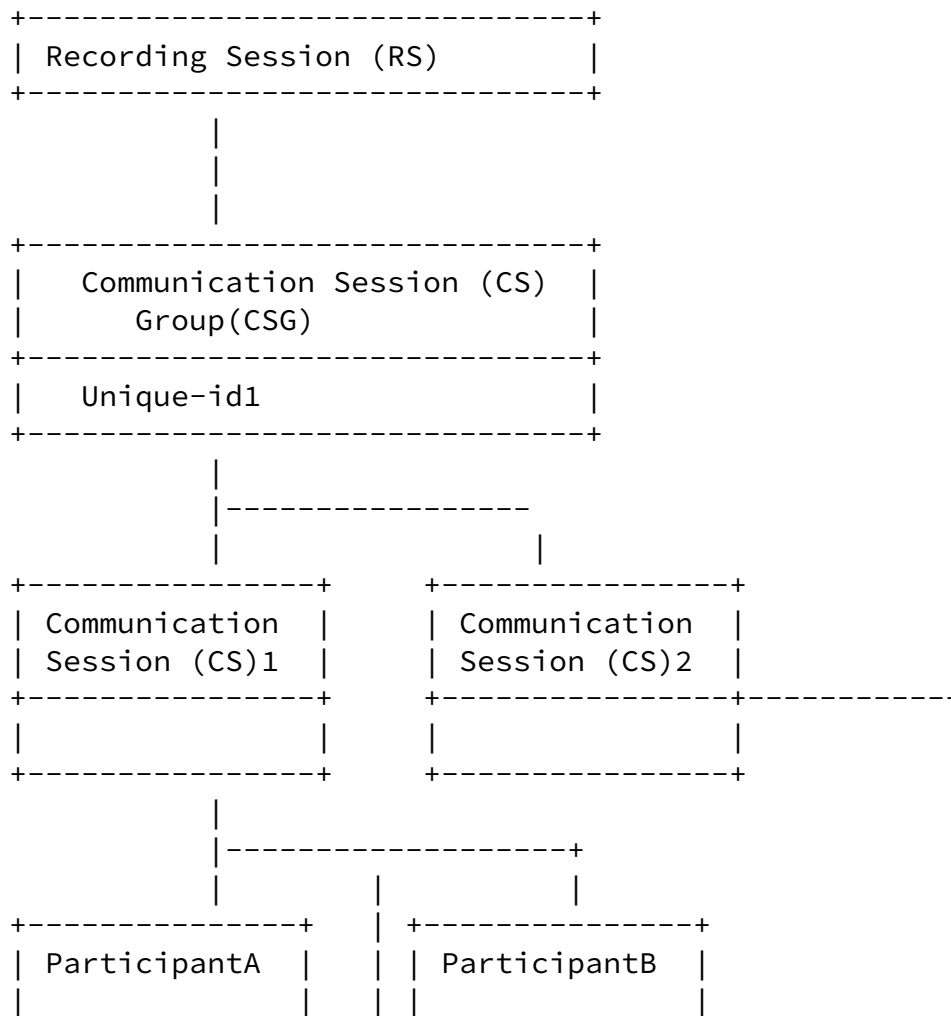

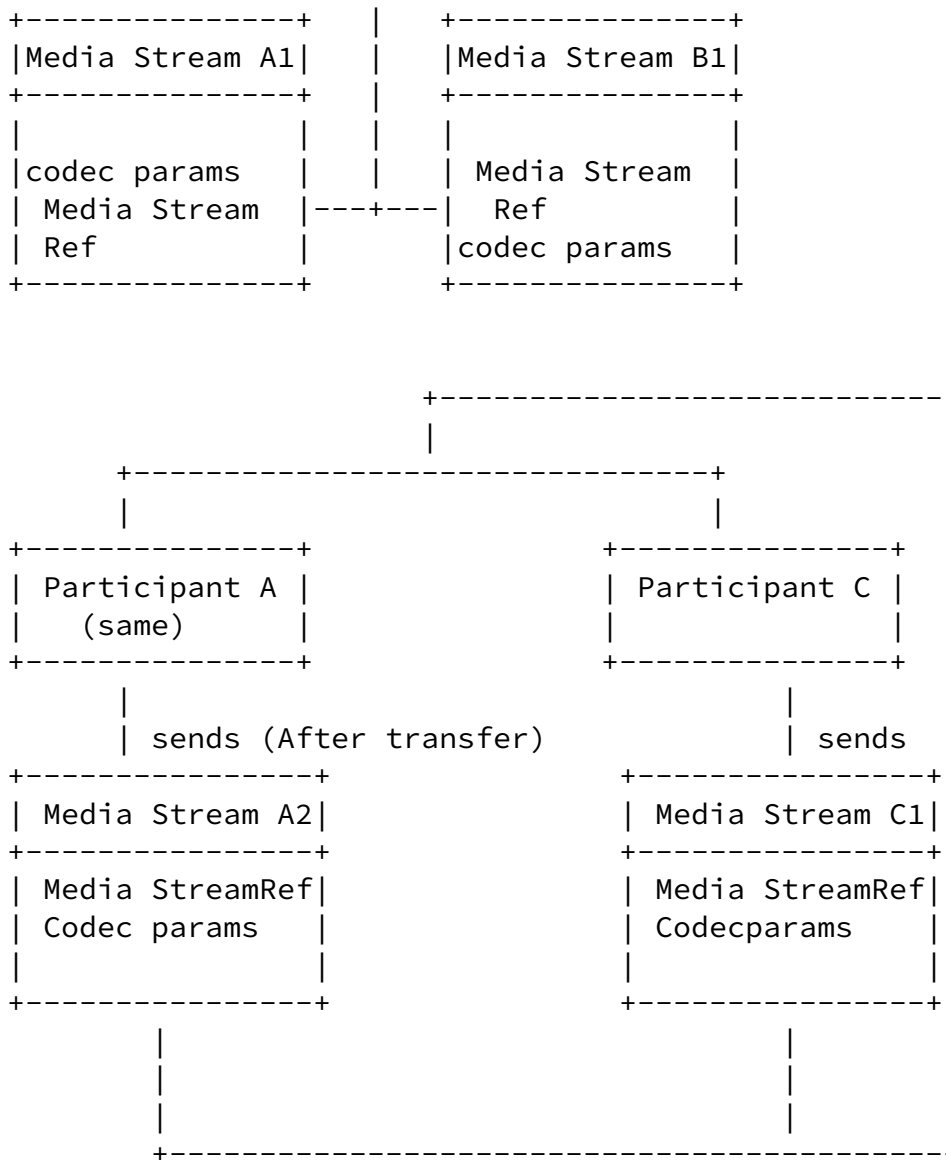

5.4. Conference Use Cases

Depending on who act as SRC and the information that an SRC has there can be several ways to model conference use cases. This section has instance diagrams for the following cases:

- o A CS where one of the participant (which is also SRC) is a user in a conference
- o A CS where one of the participant is focus (which is also SRC)

Internet-Draft

SIP Recording Metadata

April 2011

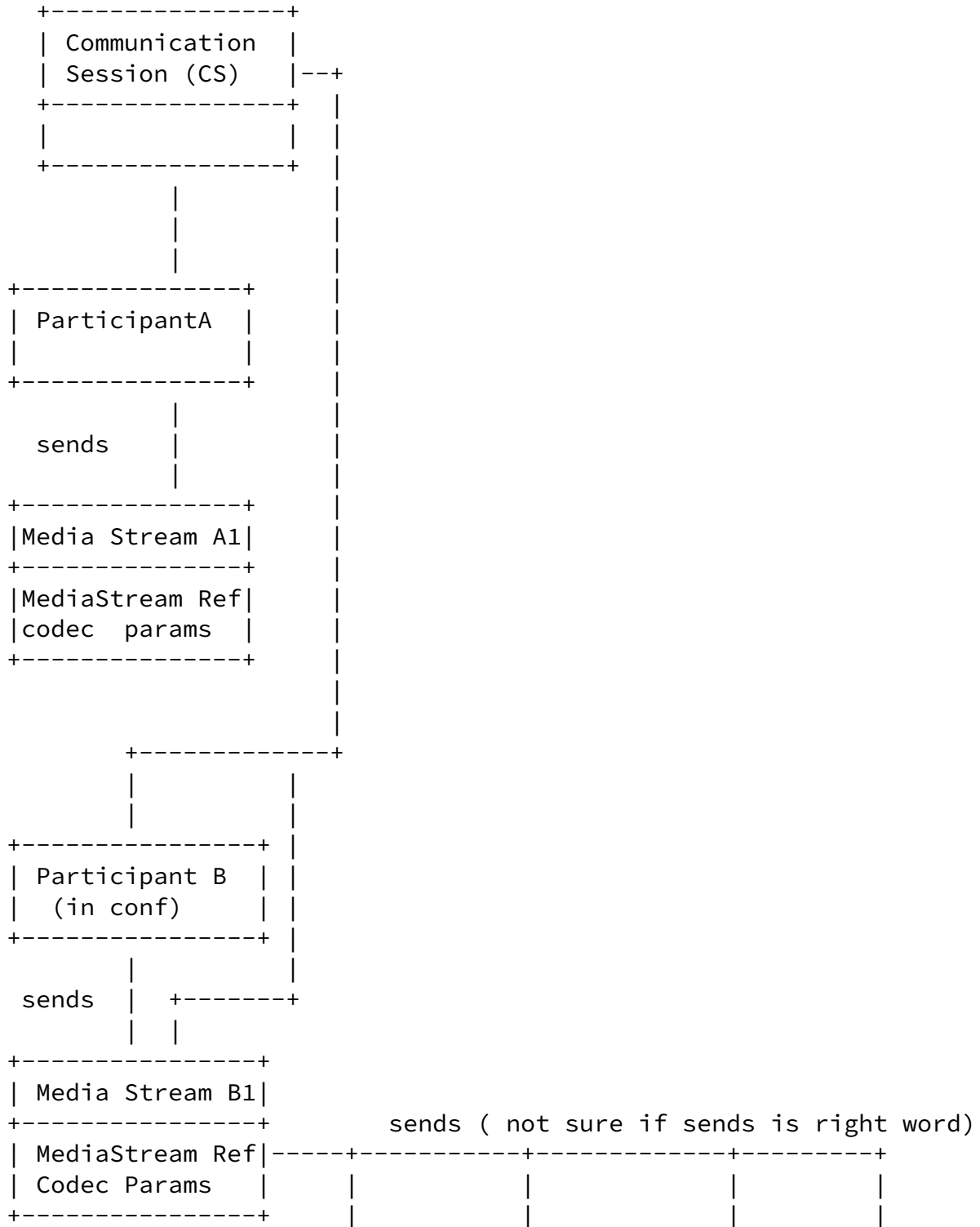

```

+-----+ +-----+ +-----+ +-----+
|participantD| |ParticipantE| |ParticipantF| |Participant G|
+-----+ +-----+ +-----+ +-----+

```

In this example we have two participants A and B who are part of a Communication Session(CS). One of the participants B is part of a

conference and also acts as SRC. There can be two cases here. B can be a participant of the conference or B can be a focus. In this instance diagram Participant B is a user in a conference. The SRC (Participant B) SHALL subscribe to conference event package to get the details of other participants. Participant B(SRC) SHALL send the same through the metadata to SRS. In this instance diagram the Media Stream(mixed stream) sent from Participant B SHALL have media streams contributed by conference participants (D,E,F and G). For the sake of simplicity the "receives" line is not shown here. In this example the media stream sent by each participant(A or B) of CS is received by all other participant(A or B).

[5.4.2.](#) Case 2:

This is the usecase where there is a CS where one of the participant is focus (which is also SRC).

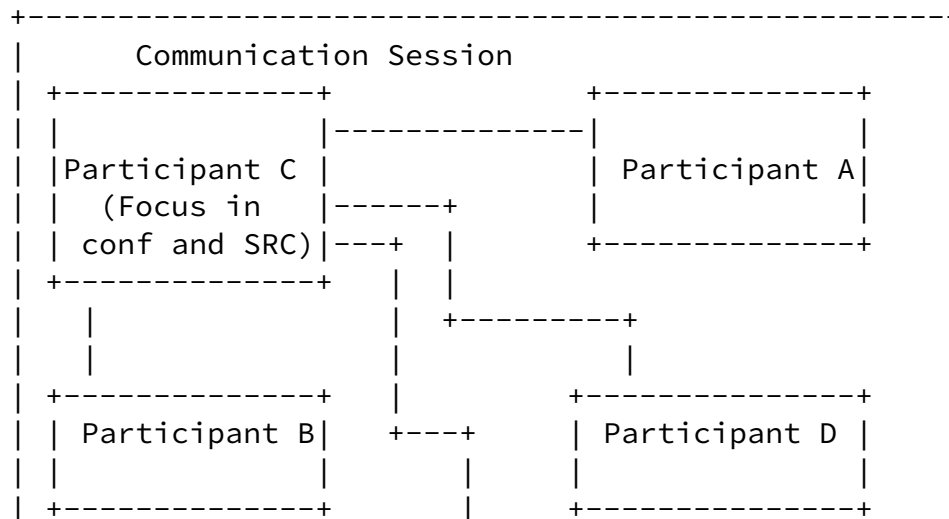

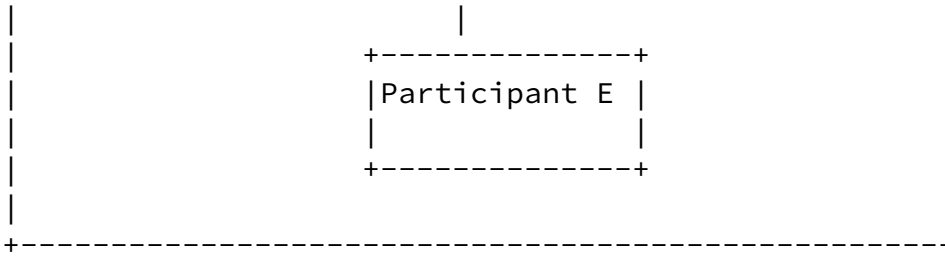

Instance Diagram:

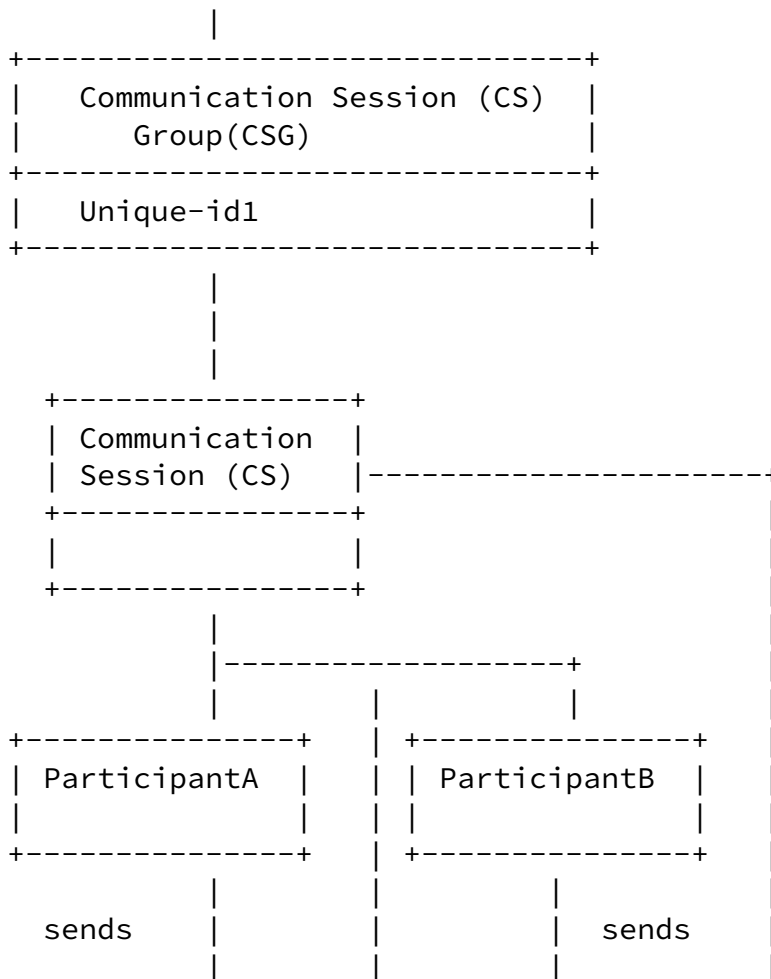
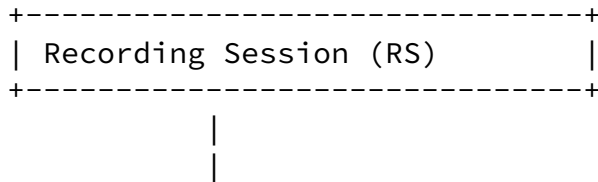

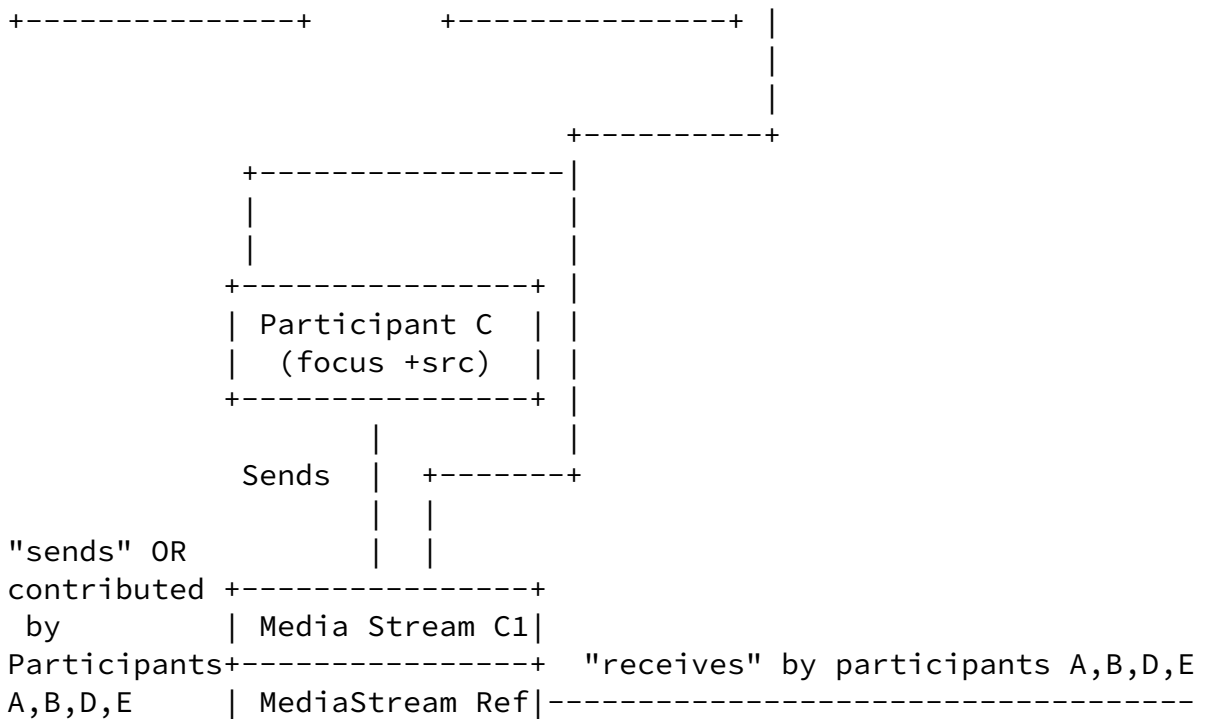
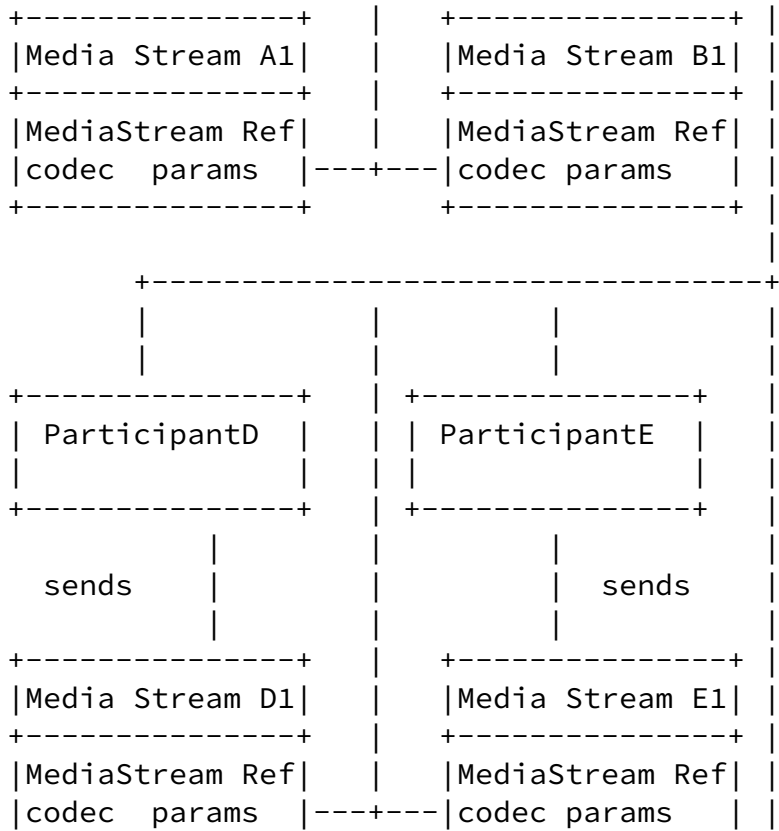

```

-----| Codec Params |
      +-----+

```

In this example we have two participants A and B who are part of a Communication Session(CS). One of the participants (C) is focus of a conference and also acts as SRC. The SRC (Participant C) being the Focus of the conference SHALL have access to the details of other participants. SRC (Participant C) SHALL send the same through the metadata to SRS. In this instance diagram the Media Stream(mixed stream) sent by C SHALL have media streams contributed by conference participants (A, B, D and E). Participants A, B,D and E SHALL send Media Streams A1, B1, D1 and E1 respectively. The media stream sent by Participant C(Focus) shall be received by all other participants of CS. For the sake of simplicity the "receives" line is not shown linked to all other participants.

NOTE: SRC (Participant C) MAY send mixed stream or seperate streams to SRS

5.4.3. Case 3:

A CS where one of the participant is user and the SRC is a different entity like B2BUA. In this case the SRC MAY not know that one of the user is part of conference. Hence the instance diagram will not have information about the conference participants.

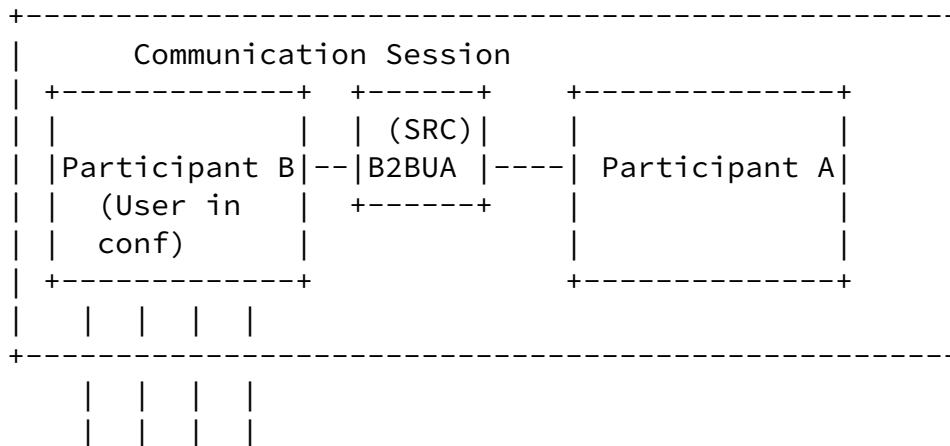

5.4.4. Case 4:

A CS where one of the participant is focus and the SRC is a different entity like B2BUA. In this case the participant which is focus MAY send "isfocus" in SIP message to SRC. The SRC MAY subscribe to conference event package on seeing this "isfocus". SRC SHALL learn the details of other participants of conference from the conference package and send the same in metadata to SRS. The instance diagram for this use case SHALL be same as Case 1.

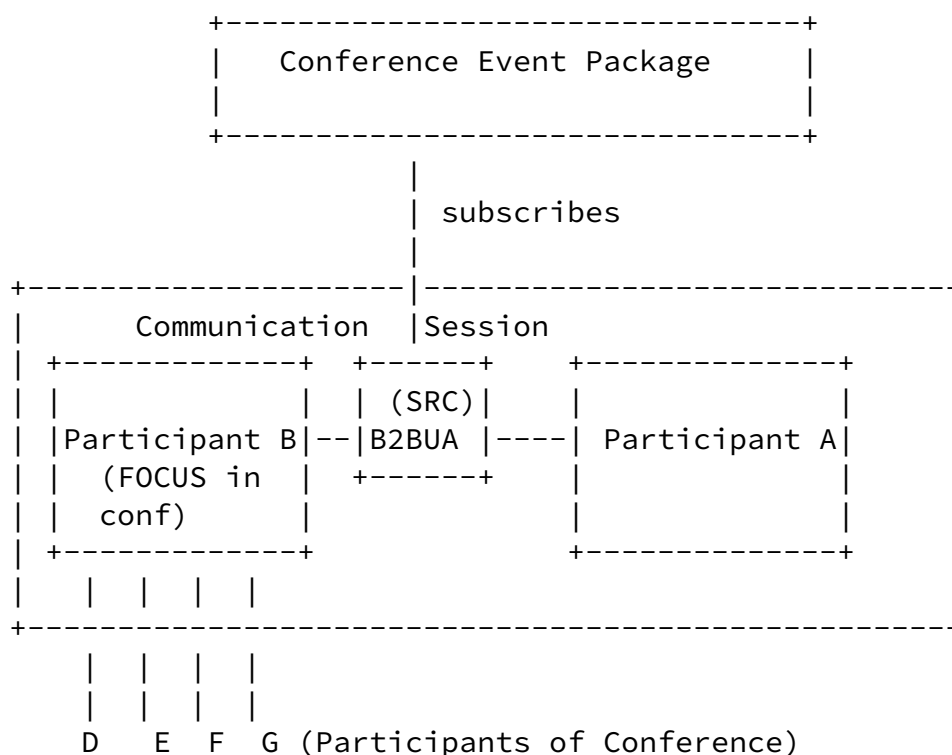

6. Security Considerations

The metadata information sent from SRC to SRS MAY reveal sensitive Information about different participants of CS. For this reason, it is RECOMMENDED that a SRC use a strong means for authentication and

metadata information protection and that it apply comprehensive authorization rules when using the metadata model defined in this document. The security considerations for this SHALL be defined in the solution document.

[7.](#) IANA Considerations

Not Applicable

[8.](#) Acknowledgement

We wish to thank John Elwell, Henry Lum, Leon Portman, De Villers, Andrew Hutton, Deepanshu Gautam, Charles Eckel for their valuable comments.

[9.](#) References

[9.1.](#) Normative References

[RFC2119] Bradner, S., "Key words for use in RFCs to Indicate Requirement Levels", [BCP 14](#), [RFC 2119](#), March 1997.

[9.2.](#) Informative References

[I-D.ietf-siprec-req]
Rehor, K., Portman, L., Hutton, A., and R. Jain, "Use Cases and Requirements for SIP-based Media Recording (SIPREC)", [draft-ietf-siprec-req-09](#) (work in progress), March 2011.

[I-D.ietf-siprec-architecture]
Hutton, A., Portman, L., Jain, R., and K. Rehor, "An Architecture for Media Recording using the Session Initiation Protocol", [draft-ietf-siprec-architecture-01](#) (work in progress), October 2010.

Authors' Addresses

Ram Mohan Ravindranath
Cisco Systems, Inc.
Cessna Business Park,
Kadabeesanahalli Village, Varthur Hobli,
Sarjapur-Marathahalli Outer Ring Road
Bangalore, Karnataka 560103
India

Email: rmohanr@cisco.com

Parthasarathi Ravindran
Cisco Systems, Inc.
Cessna Business Park,
Kadabeesanahalli Village, Varthur Hobli,
Sarjapur-Marathahalli Outer Ring Road
Bangalore, Karnataka 560103
India

Email: partr@cisco.com

Paul Kyzivat
Cisco Systems, Inc.
1414 Massachusetts Avenue
Boxborough, MA 01719
USA

Email: pkyzivat@cisco.com

