

TEAS WG  
Internet Draft  
Intended status: Informational  
Expires: August 19, 2020

Young Lee  
Samsung  
Haomian Zheng  
Huawei Technologies  
Daniele Ceccarelli  
Ericsson  
Bin Yeong Yoon  
ETRI  
Oscar Gonzalez de Dios  
Telefonica  
Jong Yoon Shin  
SKT  
Sergio Belotti  
Nokia

February 19, 2020

Applicability of YANG models for Abstraction and Control of Traffic  
Engineered Networks

[draft-ietf-teas-actn-yang-05](#)

Status of this Memo

This Internet-Draft is submitted to IETF in full conformance with the provisions of [BCP 78](#) and [BCP 79](#).

Internet-Drafts are working documents of the Internet Engineering Task Force (IETF), its areas, and its working groups. Note that other groups may also distribute working documents as Internet-Drafts.

Internet-Drafts are draft documents valid for a maximum of six months and may be updated, replaced, or obsoleted by other documents at any time. It is inappropriate to use Internet-Drafts as reference material or to cite them other than as "work in progress."

The list of current Internet-Drafts can be accessed at <http://www.ietf.org/ietf/lid-abstracts.txt>

The list of Internet-Draft Shadow Directories can be accessed at <http://www.ietf.org/shadow.html>.

This Internet-Draft will expire on August 19, 2020.

Internet-Draft

ACTN YANG

February 2020

## Copyright Notice

Copyright (c) 2020 IETF Trust and the persons identified as the document authors. All rights reserved.

This document is subject to [BCP 78](#) and the IETF Trust's Legal Provisions Relating to IETF Documents (<http://trustee.ietf.org/license-info>) in effect on the date of publication of this document. Please review these documents carefully, as they describe your rights and restrictions with respect to this document. Code Components extracted from this document must include Simplified BSD License text as described in Section 4.e of the [Trust Legal Provisions](#) and are provided without warranty as described in the Simplified BSD License.

## Abstract

Abstraction and Control of TE Networks (ACTN) refers to the set of virtual network operations needed to orchestrate, control and manage large-scale multi-domain TE networks, so as to facilitate network programmability, automation, efficient resource sharing, and end-to-end virtual service aware connectivity and network function virtualization services.

This document explains how the different types of YANG models defined in the Operations and Management Area and in the Routing Area are applicable to the ACTN framework. This document also shows how the ACTN architecture can be satisfied using classes of data model that have already been defined, and discusses the applicability of specific data models that are under development. It also highlights where new data models may need to be developed.

## Table of Contents

<a href="#">1.</a>	Introduction .....	<a href="#">3</a>
<a href="#">1.1.</a>	Conventions Used in This Document .....	<a href="#">3</a>
<a href="#">2.</a>	Abstraction and Control of TE Networks (ACTN) Architecture...	<a href="#">4</a>
<a href="#">3.</a>	Service Models .....	<a href="#">5</a>
<a href="#">4.</a>	Service Model Mapping to ACTN .....	<a href="#">7</a>
<a href="#">4.1.</a>	Customer Service Models in the ACTN Architecture (CMI)...	<a href="#">7</a>

<a href="#">4.2.</a>	Service Delivery Models in ACTN Architecture .....	<a href="#">8</a>
<a href="#">4.3.</a>	Network Configuration Models in ACTN Architecture (MPI).	8
<a href="#">4.4.</a>	Device Models in ACTN Architecture (SBI) .....	<a href="#">9</a>

<a href="#">5.</a>	Examples of Using Different Types of YANG Models .....	<a href="#">10</a>
<a href="#">5.1.</a>	Topology Collection .....	<a href="#">10</a>
<a href="#">5.2.</a>	Connectivity over Two Nodes .....	<a href="#">10</a>
<a href="#">5.3.</a>	VN example .....	<a href="#">11</a>
<a href="#">5.4.</a>	Data Center-Interconnection Example .....	<a href="#">12</a>
<a href="#">5.4.1.</a>	CMI (CNC-MDSC Interface) .....	<a href="#">14</a>
<a href="#">5.4.2.</a>	MPI (MDSC-PNC Interface) .....	<a href="#">14</a>
<a href="#">5.4.3.</a>	SBI (Southbound interface between PNC and devices).	14
<a href="#">6.</a>	Security .....	<a href="#">15</a>
<a href="#">7.</a>	IANA Considerations .....	<a href="#">15</a>
<a href="#">8.</a>	Acknowledgements .....	<a href="#">15</a>
<a href="#">9.</a>	References .....	<a href="#">15</a>
<a href="#">9.1.</a>	Informative References .....	<a href="#">15</a>
<a href="#">10.</a>	Contributors .....	<a href="#">18</a>
	Authors' Addresses .....	<a href="#">18</a>

## [1.](#) Introduction

Abstraction and Control of TE Networks (ACTN) describes a method for operating a Traffic Engineered (TE) network (such as an MPLS-TE network or a layer 1 transport network) to provide connectivity and virtual network for customers of the TE network. The services provided can be tuned to meet the requirements (such as traffic patterns, quality, and reliability) of the applications hosted by the customers. More details about ACTN can be found in [Section 2](#).

Data models are a representation of objects that can be configured or monitored within a system. Within the IETF, YANG [[RFC6241](#)] is the language of choice for documenting data models, and YANG models have been produced to allow configuration or modelling of a variety of network devices, protocol instances, and network services. YANG data models have been classified in [[RFC8199](#)] and [[RFC8309](#)].

This document shows how the ACTN architecture can be satisfied using various classes of data model that have already been defined, and discusses the applicability of specific data models that are under development. It also highlights where new data models may need to be developed.

1.1. Conventions Used in This Document

The key words "MUST", "MUST NOT", "REQUIRED", "SHALL", "SHALL NOT", "SHOULD", "SHOULD NOT", "RECOMMENDED", "NOT RECOMMENDED", "MAY", and "OPTIONAL" in this document are to be interpreted as described in [BCP 14 \[RFC2119\]](#) [[RFC8174](#)] when, and only when, they appear in all capitals, as shown here.

2. Abstraction and Control of TE Networks (ACTN) Architecture

[RFC8453] describes the architecture model for ACTN including the entities (Customer Network Controller (CNC), Multi-domain Service Coordinator (MDSC), and Provisioning Network Controller (PNC)) and their interfaces.

Figure 1 depicts a high-level control and interface architecture for ACTN and is a reproduction of Figure 3 from [[RFC8453](#)]. A number of key ACTN interfaces exist for deployment and operation of ACTN-based networks. These are highlighted in Figure 1 (ACTN Interfaces) below:

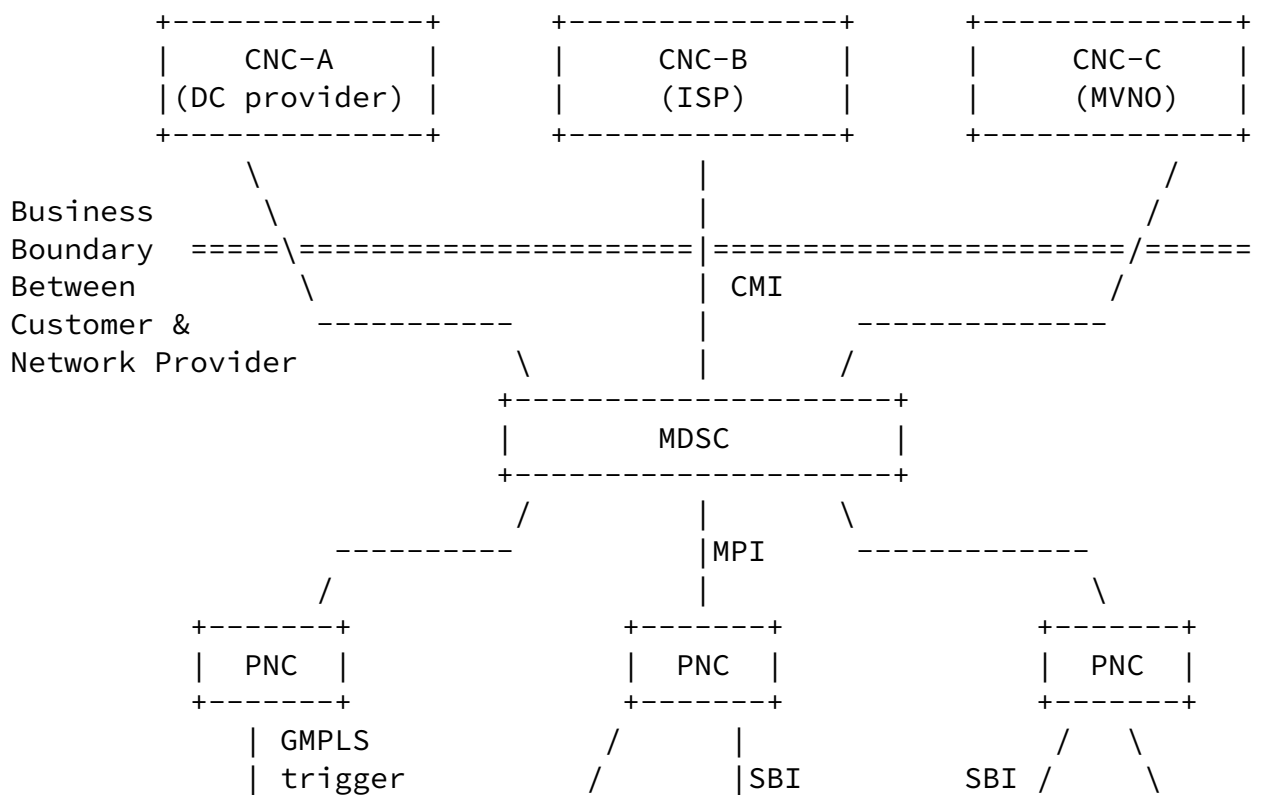

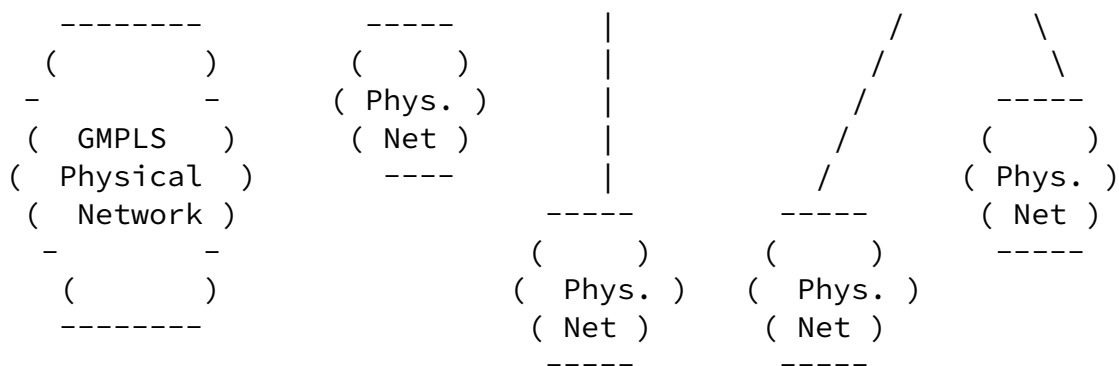

Figure 1 : ACTN Interfaces

The interfaces and functions are described below (without modifying the definitions) in [\[RFC8453\]](#):

The CNC-MDSC Interface (CMI) is an interface between a CNC and an MDSC. This interface is used to communicate the service request or application demand. A request will include specific service properties, for example, services type, bandwidth and constraint information. These constraints SHOULD be measurable by MDSC and therefore visible to CNC via CMI. The CNC can also request the creation of the virtual network based on underlying physical resources to provide network services for the applications. The CNC can provide the end-point information/characteristics together with traffic matrix specifying specific customer constraints. The MDSC may also report potential network topology availability if queried for current capability from the Customer Network Controller. Performance monitoring is also applicable in CMI, which enables the MDSC to report network parameters/telemetries that may guide the CNC to create/change their services.

The MDSC-PNC Interface (MPI) is an interface between a MDSC and a PNC. It allows the MDSC to communicate requests to create/delete connectivity or to modify bandwidth reservations in the physical network. In multi-domain environments, each PNC is responsible for a separate domain. The MDSC needs to establish multiple MPIs, one for each PNC and perform

coordination between them to provide cross-domain connectivity. MPI plays an important role for multi-vendor mechanism, interoperability can be achieved by standardized interface modules.

The South-Bound Interface (SBI) is the provisioning interface for creating forwarding state in the physical network, requested via the PNC. The SBI is not in the scope of ACTN, however, it is included in this document so that it can be compared to models in [RFC8309].

### 3. Service Models

[RFC8309] introduces a reference architecture to explain the nature and usage of service YANG models in the context of service orchestration. Figure 2 below depicts this relationship and is a reproduction of Figure 2 from [RFC8309]. Four models depicted in Figure 2 are defined as follows:

**Customer Service Model:** A customer service model is used to describe a service as offer or delivered to a customer by a network operator.

**Service Delivery Model:** A service delivery model is used by a network operator to define and configure how a service is provided by the network.

**Network Configuration Model:** A network configuration model is used by a network orchestrator to provide network-level configuration model to a controller.

**Device Configuration Model:** A device configuration model is used by a controller to configure physical network elements.

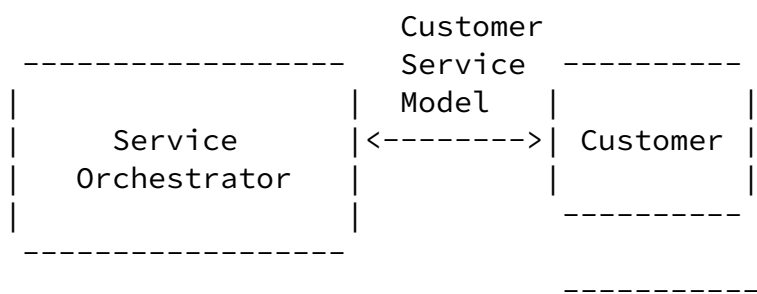

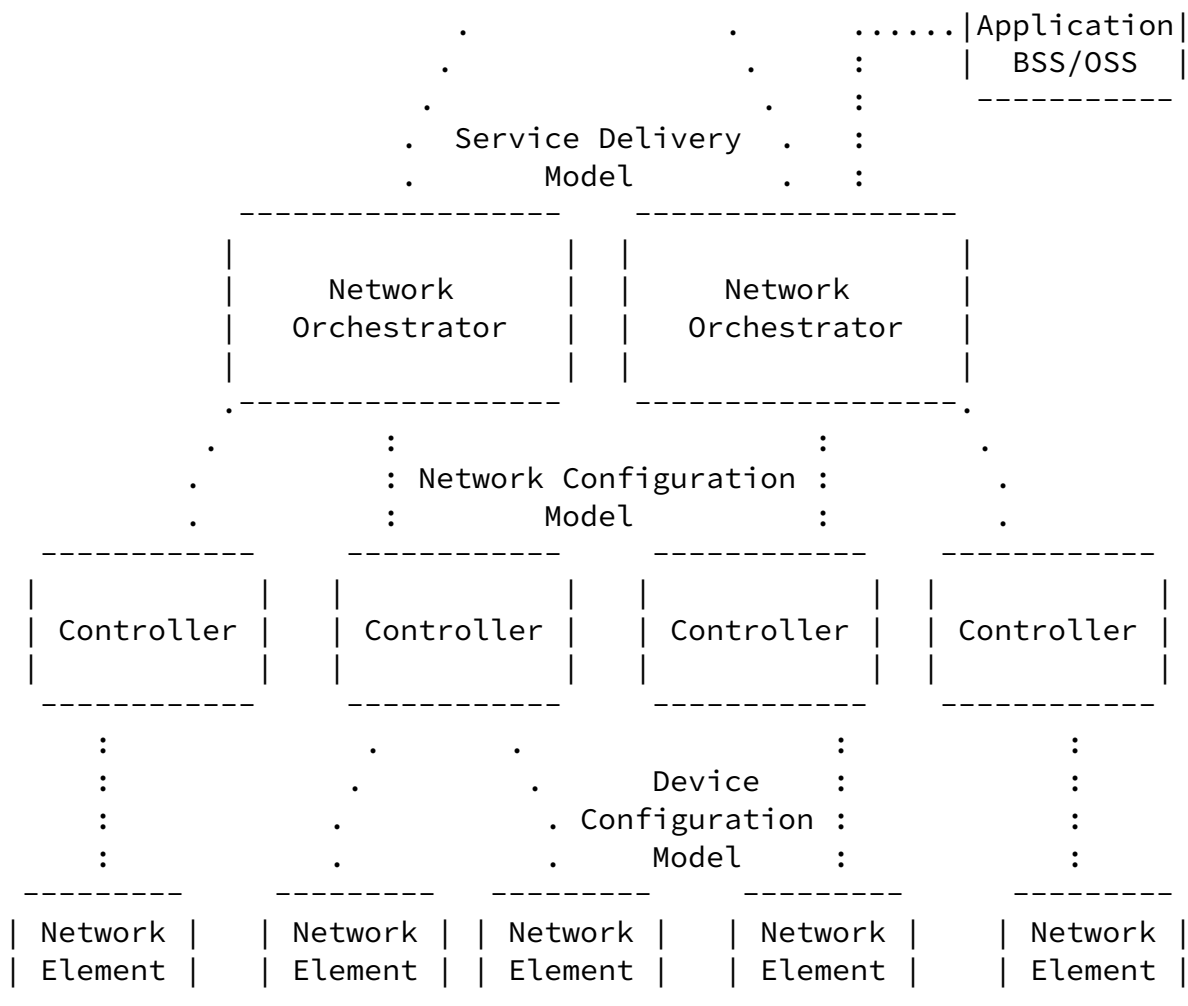

Figure 2: An SDN Architecture with a Service Orchestrator

#### 4. Service Model Mapping to ACTN

YANG models coupled with the RESTCONF/NETCONF protocol [RFC6241][RFC8040] provides solutions for the ACTN framework. This section explains which types of YANG models apply to each of the ACTN interfaces.

Refer to Figure 5 of [RFC8453] for details of the mapping between ACTN functions and service models. In summary, the following mappings are held between and Service Yang Models in [RFC8309] and the ACTN interfaces in [RFC8453].

- o Customer Service Model <-> CMI
- o Network Configuration Model <-> MPI
- o Device Configuration Model <-> SBI

#### 4.1. Customer Service Models in the ACTN Architecture (CMI)

Customer Service Models, which are used between a customer and a service orchestrator as in [RFC8309], should be used between the CNC and MDSC (e.g., CMI) serving as providing a simple intent-like model/interface.

Among the key functions of Customer Service Models on the CMI is the service request. A request will include specific service properties, including: service type and its characteristics, bandwidth, constraint information, and end-point characteristics.

The following table provides a list of functions needed to build the CMI. They are mapped with Customer Service Models.

Function	Yang Model
VN Service Request	[ACTN-VN-YANG]
VN Computation Request	[ACTN-VN-YANG] *
TE & Service Mapping	[TE-Service-Mapping]**
VN Performance Monitoring Telemetry	[ACTN-PM-Telemetry]***
Topology Abstraction	[TE-topology]****
Layer 1 Connectivity Service Model	[L1CSM]
Layer 2 VPN Service Model	[RFC8466]
Layer 3 VPN Service Model	[RFC8299]

\*VN computation request in the CMI context means network path computation request based on customer service connectivity request constraints prior to the instantiation of a VN creation.

\*\*[TE-Service-Mapping] provides a mapping and cross-references between service models (e.g., L3SM, L2SM, L1CSM) and TE model via [ACTN-VN-YANG] and [TE-topology]. This model can be used as either Customer Service Models, or Service Delivery model described in [Section 4.2](#).



\*\*\*ietf-actn-te-kpi-telemetry model in [[ACTN-PM-Telemetry](#)] describes performance telemetry for ACTN VN model. This module also allows autonomic traffic engineering scaling intent configuration mechanism on the VN level. Scale in/out criteria might be used for network autonomies in order the controller to react to a certain set of variations in monitored parameters. Moreover, this module also provides mechanism to define aggregated telemetry parameters as a grouping of underlying VN level telemetry parameters.

\*\*\*\*TE-Topology's Connectivity Matrices/Matrix construct can be used to instantiate VN Service via a suitable referencing and mapping with [[ACTN-VN-YANG](#)].

#### [4.2.](#) Service Delivery Models in ACTN Architecture

The Service Delivery Models where the service orchestration and the network orchestration could be implemented as separate components as seen in [[RFC8309](#)]. On the other hand, from an ACTN architecture point of view, the service delivery model between the service orchestrator and the network orchestrator is an internal interface between sub-components of the MDSC in a single MDSC model.

In the MDSC hierarchical model where there are multiple MDSCs, the interface between the top MDSC and the bottom MDSC can be mapped to service delivery models.

#### [4.3.](#) Network Configuration Models in ACTN Architecture (MPI)

The Network Configuration Models is used between the network orchestrator and the controller in [[RFC8309](#)]. In ACTN, this model is used primarily between a MDSC and a PNC. The Network Configuration Model can be also used for the foundation of more advanced models, like hierarchical MDSCs (see [Section 4.5](#))

The Network Configuration Model captures the parameters which are network wide information.

The following table provides a list of functions needed to build the MPI. They are mapped with Network Configuration Yang Models. Note that various Yang models are work in progress.

Function	Yang Model
Configuration Scheduling	[ <a href="#">Schedule</a> ]
Path computation	[PATH_COMPUTATION-API]
Tunnel/LSP Provisioning	[ <a href="#">TE-tunnel</a> ]
Topology Abstraction	[ <a href="#">TE-topology</a> ]
Service Provisioning	[ <a href="#">Client-signal</a> ]&[ <a href="#">TE-tunnel</a> ]*
Client Topology Abstraction	[ <a href="#">Client-topo</a> ]
OTN Topology Abstraction	[ <a href="#">OTN-topo</a> ]
WSON Topology Abstraction	[ <a href="#">WSON-topo</a> ]
Flexi-grid Topology Abstraction	[ <a href="#">Flexi-topo</a> ]
Microwave Topology Abstraction	[ <a href="#">MW-topo</a> ]
Client Signal Description	[ <a href="#">Client-signal</a> ]
OTN Tunnel Model	[ <a href="#">OTN-Tunnel</a> ]
WSON TE Tunnel Model	[ <a href="#">WSON-Tunnel</a> ]
Flexi-grid Tunnel Model	[ <a href="#">Flexigrid-Tunnel</a> ]

\* This function is a combination of tunnel set up and client signal description. Usually a tunnel is setting up first to get prepared to carry a client signal, in order to do the service provisioning. Then the client signal is adapted to the established tunnel. It is worth noting that various tunnel models such as [[OTN-Tunnel](#)] and [[WSON-Tunnel](#)] can be used together with the [[TE-tunnel](#)] model to construct technology-specific tunnels, and carry different types of client signals. More details can be found in [[Client-signal](#)].

[[TE-topo-tunnel](#)] provides the clarification and example usage for TE topology model [[TE-topology](#)] and TE tunnel model [[TE-tunnel](#)]. [T-NBI Applicability] provides a summary on the applicability of existing YANG model usage in the current network configuration, especially for transport network.

#### [4.4](#). Device Models in ACTN Architecture (SBI)

Note that SBI is not in the scope of ACTN, as there is already mature protocol solutions for various purpose on the device level of

interworking of such protocols and ACTN controller hierarchies can be found in [[gmpls-controller-inter-work](#)].

For the device YANG models are used for per-device configuration purpose, they can be used between the PNC and the physical network/devices. One example of Device Models is ietf-te-device yang module defined in [[TE-tunnel](#)].

## [5.](#) Examples of Using Different Types of YANG Models

This section provides some examples on the usage of IETF YANG models in the network operation. A few typical generic scenarios are involved. In [T-NBI Applicability], there are more transport-related scenarios and examples.

### [5.1.](#) Topology Collection

Before any connection is requested and delivered, the controller needs to understand the network topology. The topology information is exchanged among controllers with topology models, such as [[TE-topology](#)]. Moreover, technology-specific topology reporting may use the model described in [[OTN-topo](#)] [[WSON-topo](#)], and [[Flexi-topo](#)] for OTN, WSON and Flexi-grid, respectively. By collecting the network topology, each controller can therefore construct a local database, which can be used for the further service deployment.

There can be different types of abstraction applied between each pair of controllers, corresponding method can be found in [[RFC8453](#)]. The technology-specific features may be hidden after abstraction, to make the network easier for the user to operate.

When there is a topology change in the physical network, the PNC should report the change to upper level of controllers via updating messages using topology models. Accordingly, such changes is propagated between different controllers for further synchronization.

### [5.2.](#) Connectivity over Two Nodes

The service models, such as described in [[RFC8299](#)], [[RFC8466](#)] and [[L1CSM](#)] provide a customer service model which can be used in provider networks.

It would be used as follows in the ACTN architecture:

A CNC uses the service models to specify the two client nodes that are to be connected, and also indicates the amount of traffic (i.e., the bandwidth required) and payload type. What may be additionally specified is the SLA that describes the required quality and resilience of the service.

The MDSC uses the information in the request to pick the right network (domain) and also to select the provider edge nodes corresponding to the customer edge nodes.

If there are multiple domains, then the MDSC needs to coordinate across domains to set up network tunnels to deliver a service. Thus coordination includes, but is not limited to, picking the right domain sequence to deliver a service.

Additionally, an MDSC can initiate the creation of a tunnel (or tunnel segment) in order to fulfill the service request from CNC based on path computation upon the overall topology information it synthesized from different PNCs. The based model that can cater this purpose is the TE tunnel model specified in [[TE-tunnel](#)]. Technology-specific tunnel configuration may use the model described in [[OTN-Tunnel](#)] [[WSON-Tunnel](#)], and [[Flexigrid-Tunnel](#)] for OTN, WSON and Flexi-grid, respectively.

Then, the PNCs need to decide the explicit route of such a tunnel or tunnel segment (in case of multiple domains) for each domain, and then create such a tunnel using protocols such as PCEP and RSVP-TE or using per-hop configuration.

### [5.3](#). VN example

The service model defined in [[ACTN-VN-YANG](#)] describes a virtual network (VN) as a service which is a set of multiple connectivity services:

A CNC will request VN to the MDSC by specifying a list of VN members. Each VN member specifies either a single connectivity service, or a source with multiple potential destination points in the case that the precise destination sites are to be determined by MDSC.

- o In the first case, the procedure is the same as the connectivity service, except that in this case, there is a list of connections requested.
- o In the second case, where the CNC requests the MDSC to select the right destination out of a list of candidates,

the MDSC needs to evaluate each candidate and then choose the best one and reply with the chosen destination for a given VN member. After this is selected, the connectivity request setup procedure is the same as in the connectivity example in [section 5.2](#).

After the VN is set up, a successful reply message is sent from MDSC to CNC, indicating the VN is ready. This message can also be achieved by using the model defined in [[ACTN-VN-YANG](#)].

#### [5.4](#). Data Center-Interconnection Example

This section describes more concretely how existing YANG models described in [Section 4](#) map to an ACTN data center interconnection use case. Figure 3 shows a use-case which shows service policy-driven Data Center selection and is a reproduction of Figure A.1 from [[RFC8454](#)].

Internet-Draft

ACTN YANG

February 2020

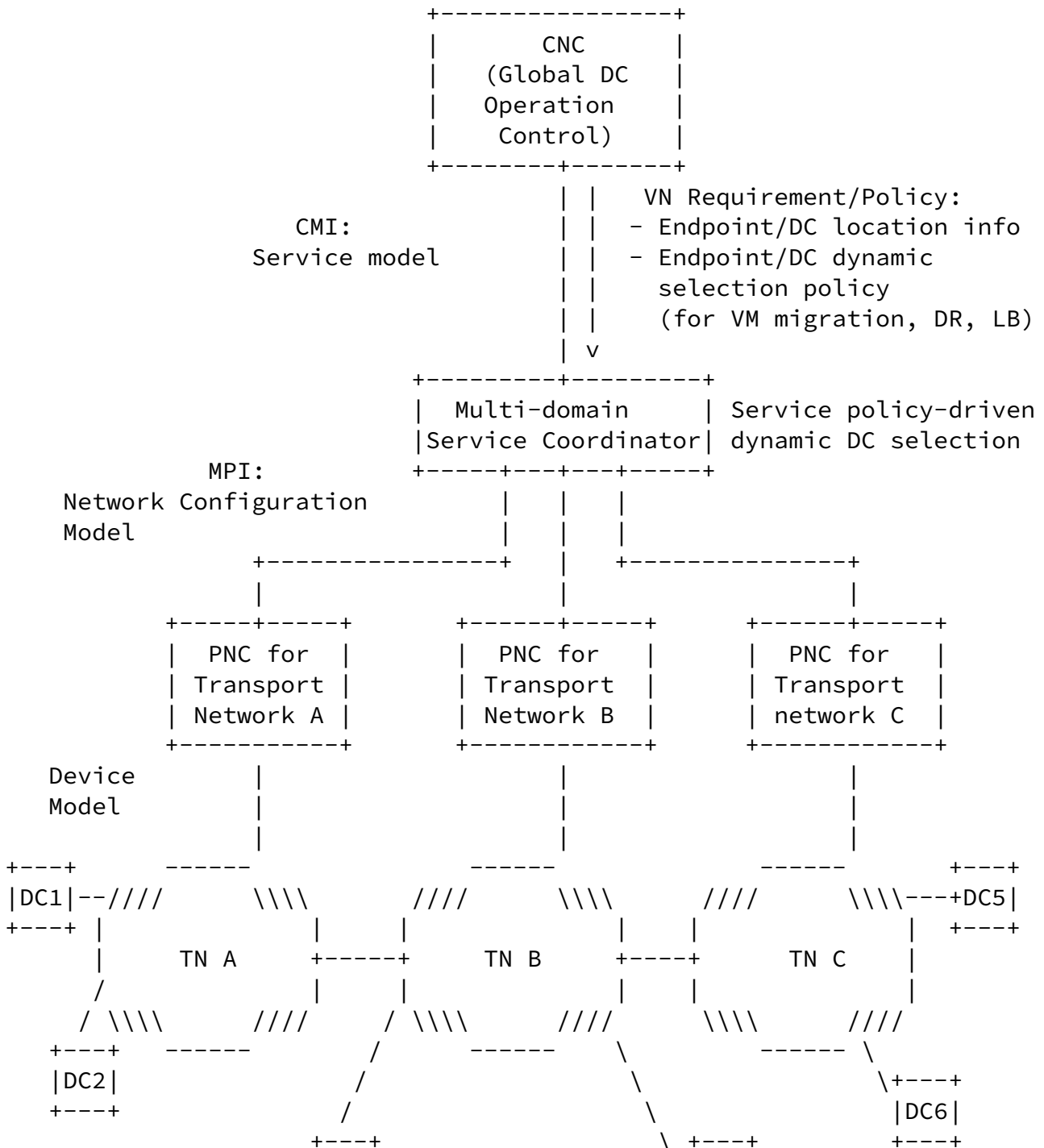

|DC3|  
+----+

\|DC4|  
+----+

DR: Disaster Recovery  
LB: Load Balancing

Figure 3: Service Policy-driven Data Center Selection

Figure 3 shows how VN policies from the CNC (Global Data Center Operation) are incorporated by the MDSC to support multi-destination applications. Multi-destination applications refer to applications in which the selection of the destination of a network path for a given source needs to be decided dynamically to support such applications.

Data Center selection problems arise for VM mobility, disaster recovery and load balancing cases. VN's policy plays an important role for virtual network operation. Policy can be static or dynamic. Dynamic policy for data center selection may be placed as a result of utilization of data center resources supporting VMs. The MDSC would then incorporate this information to meet the objective of this application.

#### 5.4.1. CMI (CNC-MDSC Interface)

[ACTN-VN-YANG] is used to express the definition of a VN, its VN creation request, the service objectives (metrics, QoS parameters, etc.), dynamic service policy when VM needs to be moved from one Data Center to another Data Center, etc. This service model is used between the CNC and the MDSC (CMI). The CNC in this use-case is an external entity that wants to create a VN and operates on the VN.

#### 5.4.2. MPI (MDSC-PNC Interface)

The Network Configuration Model is used between the MDSC and the PNCs. Based on the Customer Service Model's request, the MDSC will need to translate the service model into the network configuration model to instantiate a set of multi-domain connections between the prescribed sources and the destinations. The MDSC will also need to dynamically interact with the CNC for dynamic policy changes initiated by the CNC. Upon the determination of the multi-domain connections, the MDSC will need to use the network configuration

model such as [[TE-tunnel](#)] to interact with each PNC involved on the path. [[TE-topology](#)] is used to for the purpose of underlying domain network abstraction from the PNC to the MDSC.

#### 5.4.3. SBI (Southbound interface between PNC and devices)

The Device Model can be used between the PNC and its underlying devices that are controlled by the PNC. The PNC will need to trigger signaling using any mechanisms it employees (e.g. [[RSVP-TE-YANG](#)]) to provision its domain path segment. There can be a plethora of choices how to control/manage its domain network. The PNC is responsible to abstract its domain network resources and update it

to the MDSC. Note that this interface is not in the scope of ACTN. This section is provided just for an illustration purpose.

## [6.](#) Security

This document is an informational draft. When the models mentioned in this draft are implemented, detailed security consideration will be given in such work.

How security fits into the whole architecture has the following components:

- the use of Restconf security between components
- the use of authentication and policy to govern which services can be requested by different parties.
- how security may be requested as an element of a service and mapped down to protocol security mechanisms as well as separation (slicing) of physical resources)

## [7.](#) IANA Considerations

This document requires no IANA actions.

## [8.](#) Acknowledgements

We thank Adrian Farrel for providing useful comments and suggestions



for this draft.

## 9. References

### 9.1. Informative References

- [RFC2119] Bradner, S., "Key words for use in RFCs to Indicate Requirement Levels", [BCP 14](#), [RFC 2119](#), DOI 10.17487/RFC2119, March 1997, <<https://www.rfc-editor.org/info/rfc2119>>.
- [RFC8174] Leiba, B., "Ambiguity of Uppercase vs Lowercase in [RFC 2119](#) Key Words", [BCP 14](#), [RFC 8174](#), DOI 10.17487/RFC8174, May 2017, <<https://www.rfc-editor.org/info/rfc8174>>.
- [RFC8309] Q. Wu, W. Liu and A. Farrel, "Service Models Explained", [RFC 8309](#).

Lee, et al.

Expires August 19, 2020

[Page 15]

---

Internet-Draft

ACTN YANG

February 2020

- [RFC8199] D. Bogdanovic, B. Claise, and C. Moberg, "YANG Module Classification", [RFC 8199](#).
- [RFC6241] Enns, R., Ed., Bjorklund, M., Ed., Schoenwaelder, J., Ed., and A. Bierman, Ed., "Network Configuration Protocol (NETCONF)", [RFC 6241](#).
- [RFC8040] A. Bierman, M. Bjorklund, and K. Watsen, "RESTCONF Protocol", [RFC 8040](#).
- [RFC8453] D. Ceccarelli and Y. Lee, "Framework for Abstraction and Control of Traffic Engineered Networks", [RFC8453](#).
- [RFC8466] B. Wen, G. Fioccola, C. Xie, L. Jalil, "A YANG Data Model for L2VPN Service Delivery", [RFC8466](#).
- [RFC8299] Q. Wu, S. Litkowski, L. Tomotaki, K. Ogaki, "YANG Data Model for L3VPN Service Delivery", [RFC8299](#).
- [RFC8454] Y. Lee & S. Belotti, "Information Model for Abstraction and Control of TE Networks (ACTN)", [RFC8454](#).

- [RSVP-TE-YANG] T. Saad (Editor), "A YANG Data Model for Resource Reservation Protocol (RSVP)", [draft-ietf-teas-yang-rsvp](#), work in progress.
- [TE-topology] X. Liu, et. al., "YANG Data Model for TE Topologies", [draft-ietf-teas-yang-te-topo](#), work in progress.
- [TE-tunnel] T. Saad (Editor), "A YANG Data Model for Traffic Engineering Tunnels and Interfaces", [draft-ietf-teas-yang-te](#), work in progress.
- [ACTN-VN-YANG] Y. Lee (Editor), "A Yang Data Model for ACTN VN Operation", [draft-lee-teas-actn-vn-yang](#), work in progress.
- [L1CSM] G. Fioccola, K. Lee, Y. Lee, D. Dhody, O. Gonzalez de-Dios, D. Ceccarelli, "A Yang Data Model for L1 Connectivity Service Model (L1CSM)", [draft-ietf-ccamp-l1csm-yang](#), work in progress.
- [Schedule] X. Liu, et. al., "A YANG Data Model for Configuration Scheduling", [draft-liu-netmod-yang-schedule](#), work in progress.

Lee, et al.

Expires August 19, 2020

[Page 16]

---

Internet-Draft

ACTN YANG

February 2020

- [OTN-topo] H. Zheng, et. al., "A YANG Data Model for Optical Transport Network Topology", [draft-ietf-ccamp-otn-topo-yang](#), work in progress.
- [WSO-Net] Y. Lee, et. al., "A Yang Data Model for WSON Optical Networks", [draft-ietf-ccamp-wson-yang](#), work in progress.
- [Flexi-topo] J.E. Lopez de Vergara, et. al., "YANG data model for Flexi-Grid Optical Networks", [draft-ietf-ccamp-flexigrid-yang](#), work in progress.
- [MW-topo] M. Ye, et. al., "A YANG Data Model for Microwave Topology", [draft-ietf-ccamp-mw-topo-yang](#), work in progress.
- [OTN-Tunnel] H. Zheng, et. al., "OTN Tunnel YANG Model", [draft-ietf-ccamp-otn-tunnel-model](#), work in progress.
- [ACTN-PM-Telemetry] Y. Lee, D. Dhody, S. Karunanithi, R. Vilalta, D.

King, and D. Ceccarelli, "YANG models for ACTN TE Performance Monitoring Telemetry and Network Autonomics", [draft-ietf-teas-actn-pm-telemetry-autonomics](#), work in progress.

[WSON-Tunnel] Y. Lee, D. Dhody, V. Lopez, D. King, B. Yoon, and R. Vilalta, "A Yang Data Model for WSON Tunnel", [draft-ietf-ccamp-wson-tunnel-model](#), work in progress.

[Flexigrid-Tunnel] J. Vergara, D. Perdices, V. Lopez, O. Gonzalez de Dios, D. King, Y. Lee, and G. Galimberti, "YANG data model for Flexi-Grid media-channels", [draft-ietf-ccamp-flexigrid-media-channel-yang](#), work in progress.

[Client-signal] H. Zheng, et al, "A YANG Data Model for Optical Transport Network Client Signals", [draft-ietf-ccamp-client-signal-yang](#), work in progress.

[Client-topo] H. Zheng, et al, "A YANG Data Model for Ethernet TE Topology", [draft-zheng-ccamp-client-topo-yang](#), work in progress.

[TE-topo-tunnel] I. Bryskin, et. al., "TE Topology and Tunnel Modeling for Transport Networks", [draft-ietf-teas-te-topo-and-tunnel-modeling](#), work in progress.

Lee, et al.

Expires August 19, 2020

[Page 17]

---

Internet-Draft

ACTN YANG

February 2020

[T-NBI Applicability] I. Busi, et al, "Transport Northbound Interface Applicability Statement and Use Cases", [draft-ietf-ccamp-transport-nbi-app-statement](#), work in progress.

[gmpls-controller-inter-work] H. Zheng, et al, "Interworking of GMPLS Control and Centralized Controller System", [draft-ietf-teas-gmpls-controller-inter-work](#), work in progress.

## [10](#). Contributors

Contributor's Addresses

Dhruv Dhody  
Huawei Technologies

Email: dhruv.ietf@gmail.com

Xian Zhang  
Huawei Technologies

Email: zhang.xian@huawei.com

#### Authors' Addresses

Young Lee  
Samsung  
Korea  
Email: younglee.tx@gmail.com

Haomian Zheng  
Huawei Technologies  
Email: zhenghaomian@huawei.com

Lee, et al.

Expires August 19, 2020

[Page 18]

---

Internet-Draft

ACTN YANG

February 2020

Daniele Ceccarelli  
Ericsson  
Torshamnsgatan,48  
Stockholm, Sweden  
Email: daniele.ceccarelli@ericsson.com

Bin Yeong Yoon  
ETRI  
Email: byyun@etri.re.kr

Oscar Gonzalez de Dios  
Telefonica  
Email: oscar.gonzalezdedios@telefonica.com

Jong Yoon Shin  
SKT  
Email: jongyoon.shin@sk.com

Sergio Belotti  
Nokia  
Email: sergio.belotti@nokia.com