

Transport Area Working Group
Internet-Draft
Updates: [3819](#) (if approved)
Intended status: Best Current Practice
Expires: January 9, 2017

B. Briscoe
Simula Research Laboratory
J. Kaippallimalil
Huawei
P. Thaler
Broadcom Corporation
July 8, 2016

**Guidelines for Adding Congestion Notification to Protocols that
Encapsulate IP
draft-ietf-tsvwg-ecn-encap-guidelines-06**

Abstract

The purpose of this document is to guide the design of congestion notification in any lower layer or tunnelling protocol that encapsulates IP. The aim is for explicit congestion signals to propagate consistently from lower layer protocols into IP. Then the IP internetwork layer can act as a portability layer to carry congestion notification from non-IP-aware congested nodes up to the transport layer (L4). Following these guidelines should assure interworking between new lower layer congestion notification mechanisms, whether specified by the IETF or other standards bodies.

Status of This Memo

This Internet-Draft is submitted in full conformance with the provisions of [BCP 78](#) and [BCP 79](#).

Internet-Drafts are working documents of the Internet Engineering Task Force (IETF). Note that other groups may also distribute working documents as Internet-Drafts. The list of current Internet-Drafts is at <http://datatracker.ietf.org/drafts/current/>.

Internet-Drafts are draft documents valid for a maximum of six months and may be updated, replaced, or obsoleted by other documents at any time. It is inappropriate to use Internet-Drafts as reference material or to cite them other than as "work in progress."

This Internet-Draft will expire on January 9, 2017.

Copyright Notice

Copyright (c) 2016 IETF Trust and the persons identified as the document authors. All rights reserved.

This document is subject to [BCP 78](#) and the IETF Trust's Legal Provisions Relating to IETF Documents (<http://trustee.ietf.org/license-info>) in effect on the date of publication of this document. Please review these documents carefully, as they describe your rights and restrictions with respect to this document. Code Components extracted from this document must include Simplified BSD License text as described in Section 4.e of the Trust Legal Provisions and are provided without warranty as described in the Simplified BSD License.

Table of Contents

1.	Introduction	3
1.1.	Scope	5
2.	Terminology	6
3.	Guidelines in All Cases	7
4.	Modes of Operation	8
4.1.	Feed-Forward-and-Up Mode	8
4.2.	Feed-Up-and-Forward Mode	10
4.3.	Feed-Backward Mode	11
4.4.	Null Mode	13
5.	Feed-Forward-and-Up Mode: Guidelines for Adding Congestion Notification	13
5.1.	IP-in-IP Tunnels with Tightly Coupled Shim Headers	14
5.2.	Wire Protocol Design: Indication of ECN Support	14
5.3.	Encapsulation Guidelines	16
5.4.	Decapsulation Guidelines	18
5.5.	Sequences of Similar Tunnels or Subnets	19
5.6.	Reframing and Congestion Markings	20
6.	Feed-Up-and-Forward Mode: Guidelines for Adding Congestion Notification	20
7.	Feed-Backward Mode: Guidelines for Adding Congestion Notification	22
8.	IANA Considerations (to be removed by RFC Editor)	23
9.	Security Considerations	23
10.	Conclusions	24
11.	Acknowledgements	24
12.	Comments Solicited	24
13.	References	25
13.1.	Normative References	25
13.2.	Informative References	25
Appendix A.	Outstanding Document Issues	30
Appendix B.	Changes in This Version (to be removed by RFC Editor)	30
	Authors' Addresses	33

1. Introduction

The benefits of Explicit Congestion Notification (ECN) described below can only be fully realised if support for ECN is added to the relevant subnetwork technology, as well as to IP. When a lower layer buffer drops a packet obviously it does not just drop at that layer; the packet disappears from all layers. In contrast, when a lower layer marks a packet with ECN, the marking needs to be explicitly propagated up the layers. The same is true if a buffer marks the outer header of a packet that encapsulates inner tunnelled headers. Forwarding ECN is not as straightforward as other headers because it has to be assumed ECN may be only partially deployed. If an egress at any layer is not ECN-aware, or if the ultimate receiver or sender is not ECN-aware, congestion needs to be indicated by dropping a packet, not marking it.

The purpose of this document is to guide the addition of congestion notification to any subnet technology or tunnelling protocol, so that lower layer equipment can signal congestion explicitly and it will propagate consistently into encapsulated (higher layer) headers, otherwise the signals will not reach their ultimate destination.

ECN is defined in the IP header (v4 and v6) [[RFC3168](#)] to allow a resource to notify the onset of queue build-up without having to drop packets, by explicitly marking a proportion of packets with the congestion experienced (CE) codepoint.

Given a suitable marking scheme, ECN removes nearly all congestion loss and it cuts delays for two main reasons:

- o It avoids the delay when recovering from congestion losses, which particularly benefits small flows or real-time flows, making their delivery time predictably short [[RFC2884](#)];
- o As ECN is used more widely by end-systems, it will gradually remove the need to configure a degree of delay into buffers before they start to notify congestion (the cause of bufferbloat). This is because drop involves a trade-off between sending a timely signal and trying to avoid impairment, whereas ECN is solely a signal not an impairment, so there is no harm triggering it earlier.

Some lower layer technologies (e.g. MPLS, Ethernet) are used to form subnetworks with IP-aware nodes only at the edges. These networks are often sized so that it is rare for interior queues to overflow. However, until recently this was more due to the inability of TCP to saturate the links. For many years, fixes such as window scaling [[RFC1323](#)] proved hard to deploy. And the New Reno variant of TCP has

remained in widespread use despite its inability to scale to high flow rates. However, now that modern operating systems are finally capable of saturating interior links, even the buffers of well-provisioned interior switches will need to signal episodes of queuing.

Propagation of ECN is defined for MPLS [[RFC5129](#)], and is being defined for TRILL [[RFC7780](#)], [[I-D.eastlake-trill-ecn-support](#)], but it remains to be defined for a number of other subnetwork technologies.

Similarly, ECN propagation is yet to be defined for many tunnelling protocols. [[RFC6040](#)] defines how ECN should be propagated for IP-in-IP [[RFC2003](#)] and IPsec [[RFC4301](#)] tunnels, and it is cited by more recent tunnelling protocols, e.g. Generic UDP Encapsulation (GUE) [[I-D.ietf-nvo3-gue](#)] and Geneve [[I-D.ietf-nvo3-geneve](#)]. However, as [Section 9.3 of RFC3168](#) pointed out, ECN support will need to be defined for other tunnelling protocols, e.g. L2TP [[RFC2661](#)], GRE [[RFC1701](#)], [[RFC2784](#)], PPTP [[RFC2637](#)] and GTP [[GTPv1](#)], [[GTPv1-U](#)], [[GTPv2-C](#)], VXLAN [[RFC7348](#)].

Incremental deployment is the most delicate aspect when adding support for ECN. The original ECN protocol in IP [[RFC3168](#)] was carefully designed so that a congested buffer would not mark a packet (rather than drop it) unless both source and destination hosts were ECN-capable. Otherwise its congestion markings would never be detected and congestion would just build up further. However, to support congestion marking below the IP layer, it is not sufficient to only check that the two end-points support ECN; correct operation also depends on the decapsulator at each subnet egress faithfully propagating congestion notifications to the higher layer. Otherwise, a legacy decapsulator might silently fail to propagate any ECN signals from the outer to the forwarded header. Then the lost signals would never be detected and again congestion would build up further. The guidelines given later require protocol designers to carefully consider incremental deployment, and suggest various safe approaches for different circumstances.

Of course, the IETF does not have standards authority over every link layer protocol. So this document gives guidelines for designing propagation of congestion notification across the interface between IP and protocols that may encapsulate IP (i.e. that can be layered beneath IP). Each lower layer technology will exhibit different issues and compromises, so the IETF or the relevant standards body must be free to define the specifics of each lower layer congestion notification scheme. Nonetheless, if the guidelines are followed, congestion notification should interwork between different technologies, using IP in its role as a 'portability layer'.

Therefore, the capitalised term 'SHOULD' or 'SHOULD NOT' are often used in preference to 'MUST' or 'MUST NOT', because it is difficult to know the compromises that will be necessary in each protocol design. If a particular protocol design chooses to contradict a 'SHOULD (NOT)' given in the advice below, it MUST include a sound justification.

It has not been possible to give common guidelines for all lower layer technologies, because they do not all fit a common pattern. Instead they have been divided into a few distinct modes of operation: feed-forward-and-upward; feed-upward-and-forward; feed-backward; and null mode. These modes are described in [Section 4](#), then in the following sections separate guidelines are given for each mode.

This document updates the advice to subnetwork designers about ECN in [Section 13 of \[RFC3819\]](#).

1.1. Scope

This document only concerns wire protocol processing of explicit notification of congestion and makes no changes or recommendations concerning algorithms for congestion marking or for congestion response (algorithm issues should be independent of the layer the algorithm operates in).

The question of congestion notification signals with different semantics to those of ECN in IP is touched on in a couple of specific cases (e.g. QCN [[IEEE802.1Qau](#)]) and with schemes with multiple severity levels such as PCN [[RFC6660](#)]). However, no attempt is made to give guidelines about schemes with different semantics that are yet to be invented.

The semantics of congestion signals can be relative to the traffic class. Therefore correct propagation of congestion signals could depend on correct propagation of any traffic class field between the layers. In this document, correct propagation of traffic class information is assumed, while what 'correct' means and how it is achieved is covered elsewhere (e.g. [[RFC2983](#)]) and is outside the scope of the present document.

Note that these guidelines do not require the subnet wire protocol to be changed to accommodate congestion notification. Another way to add congestion notification without consuming header space in the subnet protocol might be to use a parallel control plane protocol.

This document focuses on the congestion notification interface between IP and lower layer protocols that can encapsulate IP, where

the term 'IP' includes v4 or v6, unicast, multicast or anycast. However, it is likely that the guidelines will also be useful when a lower layer protocol or tunnel encapsulates itself (e.g. Ethernet MAC in MAC [[IEEE802.1Qah](#)]) or when it encapsulates other protocols. In the feed-backward mode, propagation of congestion signals for multicast and anycast packets is out-of-scope (because it would be so complicated that it is hoped no-one would attempt such an abomination).

2. Terminology

The key words "MUST", "MUST NOT", "REQUIRED", "SHALL", "SHALL NOT", "SHOULD", "SHOULD NOT", "RECOMMENDED", "MAY", and "OPTIONAL" in this document are to be interpreted as described in [RFC 2119](#) [[RFC2119](#)].

Further terminology used within this document:

Protocol data unit (PDU): Information that is delivered as a unit among peer entities of a layered network consisting of protocol control information (typically a header) and possibly user data (payload) of that layer. The scope of this document includes layer 2 and layer 3 networks, where the PDU is respectively termed a frame or a packet (or a cell in ATM). PDU is a general term for any of these. This definition also includes a payload with a shim header lying somewhere between layer 2 and 3.

Transport: The end-to-end transmission control function, conventionally considered at layer-4 in the OSI reference model. Given the audience for this document will often use the word transport to mean low level bit carriage, whenever the term is used it will be qualified, e.g. 'L4 transport'.

Encapsulator: The link or tunnel endpoint function that adds an outer header to a PDU (also termed the 'link ingress', the 'subnet ingress', the 'ingress tunnel endpoint' or just the 'ingress' where the context is clear).

Decapsulator: The link or tunnel endpoint function that removes an outer header from a PDU (also termed the 'link egress', the 'subnet egress', the 'egress tunnel endpoint' or just the 'egress' where the context is clear).

Incoming header: The header of an arriving PDU before encapsulation.

Outer header: The header added to encapsulate a PDU.

Inner header: The header encapsulated by the outer header.

Outgoing header: The header forwarded by the decapsulator.

CE: Congestion Experienced [[RFC3168](#)]

ECT: ECN-Capable Transport [[RFC3168](#)]

Not-ECT: Not ECN-Capable Transport [[RFC3168](#)]

Load Regulator: For each flow of PDUs, the transport function that is capable of controlling the data rate. Typically located at the data source, but in-path nodes can regulate load in some congestion control arrangements (e.g. admission control, policing nodes or transport circuit-breakers [[I-D.ietf-tsvwg-circuit-breaker](#)]). Note the term "a function capable of controlling the load" deliberately includes a transport that doesn't actually control the load responsively but ideally it ought to (e.g. a sending application without congestion control that uses UDP).

ECN-PDU: A PDU that is part of a feedback loop within which all the nodes that need to propagate explicit congestion notifications back to the Load Regulator are ECN-capable. An IP packet with a non-zero ECN field implies that the endpoints are ECN-capable, so this would be an ECN-PDU. However, ECN-PDU is intended to be a general term for a PDU at any layer, not just IP.

Not-ECN-PDU: A PDU that is part of a feedback-loop within which some nodes necessary to propagate explicit congestion notifications back to the load regulator are not ECN-capable.

Congestion Baseline: The location of the function on the path that initialised the values of all congestion notification fields in a sequence of packets, before any are set to the congestion experienced (CE) codepoint if they experience congestion further downstream. Typically the original data source at layer-4.

3. Guidelines in All Cases

[RFC 3168](#) specifies that the ECN field in the IP header is intended to be marked by active queue management algorithms. Any congestion notification from an algorithm that does not conform to the recommendations in [[RFC7567](#)] MUST NOT be propagated from a lower layer into the ECN field in IP (see also [[RFC4774](#)] on alternate uses of the ECN field).

4. Modes of Operation

This section sets down the different modes by which congestion information is passed between the lower layer and the higher one. It acts as a reference framework for the following sections, which give normative guidelines for designers of explicit congestion notification protocols, taking each mode in turn:

Feed-Forward-and-Up: Nodes feed forward congestion notification towards the egress within the lower layer then up and along the layers towards the end-to-end destination at the transport layer. The following local optimisation is possible:

Feed-Up-and-Forward: A lower layer switch feeds-up congestion notification directly into the ECN field in the higher layer (e.g. IP) header, irrespective of whether the node is at the egress of a subnet.

Feed-Backward: Nodes feed back congestion signals towards the ingress of the lower layer and (optionally) attempt to control congestion within their own layer.

Null: Nodes cannot experience congestion at the lower layer except at ingress nodes (which are IP-aware or equivalently higher-layer-aware).

4.1. Feed-Forward-and-Up Mode

Like IP and MPLS, many subnet technologies are based on self-contained protocol data units (PDUs) or frames sent unreliably. They provide no feedback channel at the subnetwork layer, instead relying on higher layers (e.g. TCP) to feed back loss signals.

In these cases, ECN may best be supported by standardising explicit notification of congestion into the lower layer protocol that carries the data forwards. It will then also be necessary to define how the egress of the lower layer subnet propagates this explicit signal into the forwarded upper layer (IP) header. It can then continue forwards until it finally reaches the destination transport (at L4). Then typically the destination will feed this congestion notification back to the source transport using an end-to-end protocol (e.g. TCP). This is the arrangement that has already been used to add ECN to IP-in-IP tunnels [[RFC6040](#)], IP-in-MPLS and MPLS-in-MPLS [[RFC5129](#)].

This mode is illustrated in Figure 1. Along the middle of the figure, layers 2, 3 and 4 of the protocol stack are shown, and one packet is shown along the bottom as it progresses across the network from source to destination, crossing two subnets connected by a

router, and crossing two switches on the path across each subnet. Congestion at the output of the first switch (shown as *) leads to a congestion marking in the L2 header (shown as C in the illustration of the packet). The chevrons show the progress of the resulting congestion indication. It is propagated from link to link across the subnet in the L2 header, then when the router removes the marked L2 header, it propagates the marking up into the L3 (IP) header. The router forwards the marked L3 header into subnet 2, and when it adds a new L2 header it copies the L3 marking into the L2 header as well, as shown by the 'C's in both layers (assuming the technology of subnet 2 also supports explicit congestion marking).

Note that there is no implication that each 'C' marking is encoded the same; a different encoding might be used for the 'C' marking in each protocol.

Finally, for completeness, we show the L3 marking arriving at the destination, where the host transport protocol (e.g. TCP) feeds it back to the source in the L4 acknowledgement (the 'C' at L4 in the packet at the top of the diagram).

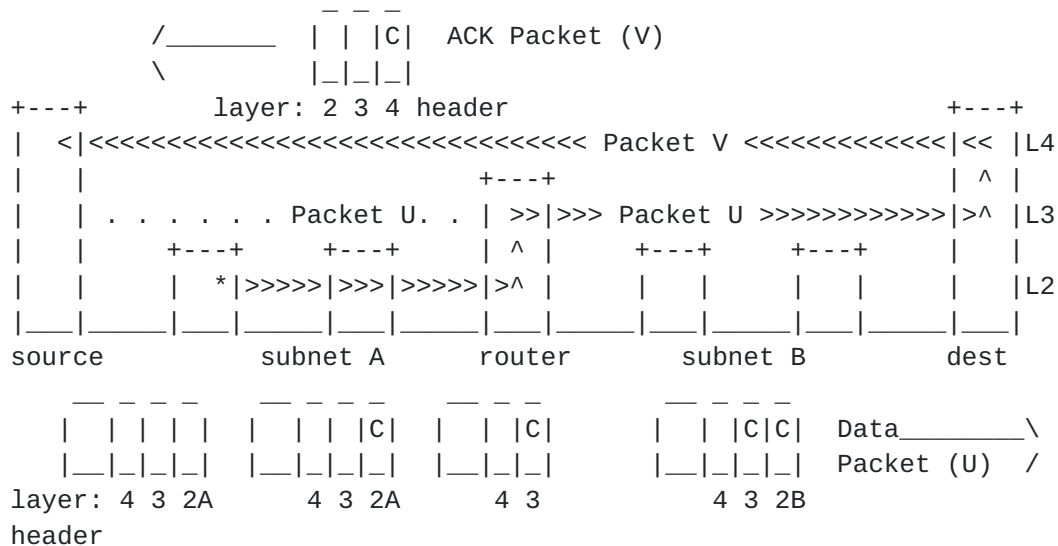

Figure 1: Feed-Forward-and-Up Mode

Of course, modern networks are rarely as simple as this text-book example, often involving multiple nested layers. For example, a 3GPP mobile network may have two IP-in-IP (GTP) tunnels in series and an MPLS backhaul between the base station and the first router. Nonetheless, the example illustrates the general idea of feeding congestion notification forward then upward whenever a header is removed at the egress of a subnet.

Note that the FECN (forward ECN) bit in Frame Relay and the explicit forward congestion indication (EFCI [ITU-T.I.371]) bit in ATM user data cells follow a feed-forward pattern. However, in ATM, this arrangement is only part of a feed-forward-and-backward pattern at the lower layer, not feed-forward-and-up out of the lower layer--the intention was never to interface to IP ECN at the subnet egress. To our knowledge, Frame Relay FECN is solely used to detect where more capacity should be provisioned [Buck00].

4.2. Feed-Up-and-Forward Mode

Ethernet is particularly difficult to extend incrementally to support explicit congestion notification. One way to support ECN in such cases has been to use so called 'layer-3 switches'. These are Ethernet switches that bury into the Ethernet payload to find an IP header and manipulate or act on certain IP fields (specifically Diffserv & ECN). For instance, in Data Center TCP [DCTCP], layer-3 switches are configured to mark the ECN field of the IP header within the Ethernet payload when their output buffer becomes congested. With respect to switching, a layer-3 switch acts solely on the addresses in the Ethernet header; it doesn't use IP addresses, and it doesn't decrement the TTL field in the IP header.

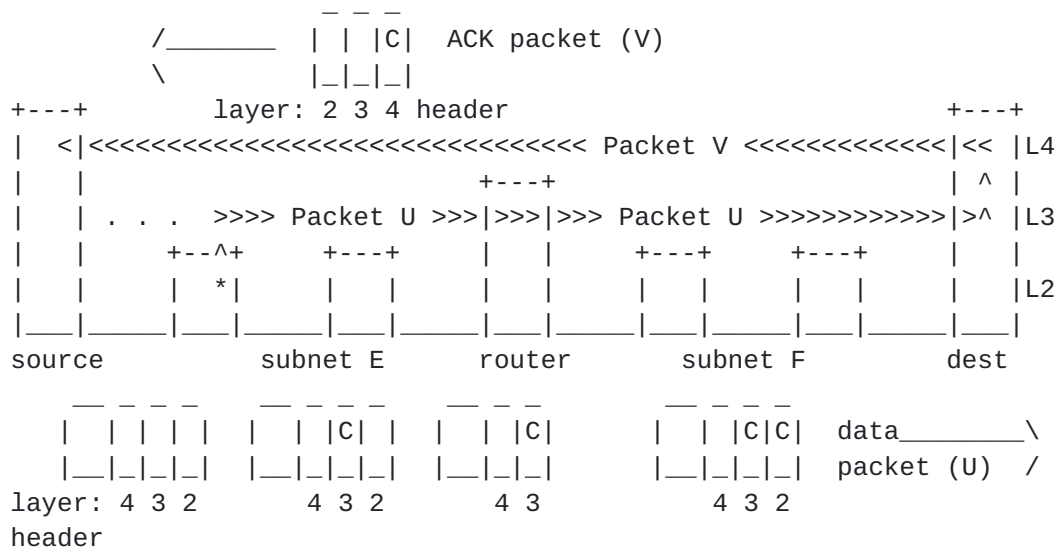

Figure 2: Feed-Up-and-Forward Mode

By comparing Figure 2 with Figure 1, it can be seen that subnet E (perhaps a subnet of layer-3 Ethernet switches) works in feed-up-and-forward mode by notifying congestion directly into L3 at the point of congestion, even though the congested switch does not otherwise act at L3. In this example, the technology in subnet F (e.g. MPLS) does

support ECN natively, so when the router adds the layer-2 header it copies the ECN marking from L3 to L2 as well.

[4.3.](#) Feed-Backward Mode

In some layer 2 technologies, explicit congestion notification has been defined for use internally within the subnet with its own feedback and load regulation, but typically the interface with IP for ECN has not been defined.

For instance, for the available bit-rate (ABR) service in ATM, the relative rate mechanism was one of the more popular mechanisms for managing traffic, tending to supersede earlier designs. In this approach ATM switches send special resource management (RM) cells in both the forward and backward directions to control the ingress rate of user data into a virtual circuit. If a switch buffer is approaching congestion or is congested it sends an RM cell back towards the ingress with respectively the No Increase (NI) or Congestion Indication (CI) bit set in its message type field [[ATM-TM-ABR](#)]. The ingress then holds or decreases its sending bit-rate accordingly.

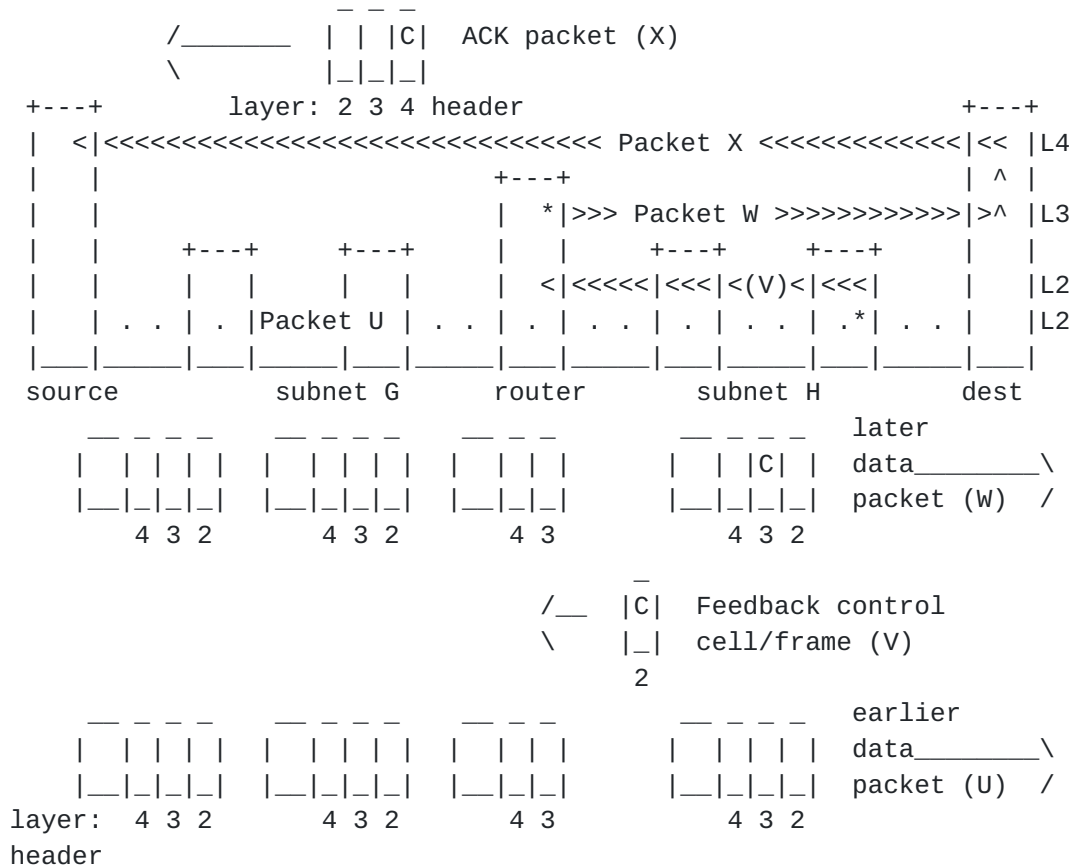

Figure 3: Feed-Backward Mode

ATM's feed-backward approach doesn't fit well when layered beneath IP's feed-forward approach--unless the initial data source is the same node as the ATM ingress. Figure 3 shows the feed-backward approach being used in subnet H. If the final switch on the path is congested (*), it doesn't feed-forward any congestion indications on packet (U). Instead it sends a control cell (V) back to the router at the ATM ingress.

However, the backward feedback doesn't reach the original data source directly because IP doesn't support backward feedback (and subnet G is independent of subnet H). Instead, the router in the middle throttles down its sending rate but the original data sources don't reduce their rates. The resulting rate mismatch causes the middle router's buffer at layer 3 to back up until it becomes congested, which it signals forwards on later data packets at layer 3 (e.g. packet W). Note that the forward signal from the middle router is not triggered directly by the backward signal. Rather, it is triggered by congestion resulting from the middle router's mismatched rate response to the backward signal.

In response to this later forward signalling, end-to-end feedback at layer-4 finally completes the tortuous path of congestion indications back to the origin data source, as before.

4.4. Null Mode

Often link and physical layer resources are 'non-blocking' by design. In these cases congestion notification may be implemented but it does not need to be deployed at the lower layer; ECN in IP would be sufficient.

A degenerate example is a point-to-point Ethernet link. Excess loading of the link merely causes the queue from the higher layer to back up, while the lower layer remains immune to congestion. Even a whole meshed subnetwork can be made immune to interior congestion by limiting ingress capacity and sufficient sizing of interior links, e.g. a non-blocking fat-tree network. An alternative to fat links near the root is numerous thin links with multi-path routing to ensure even worst-case patterns of load cannot congest any link, e.g. a Clos network.

5. Feed-Forward-and-Up Mode: Guidelines for Adding Congestion Notification

Feed-forward-and-up is the mode already used for signalling ECN up the layers through MPLS into IP [[RFC5129](#)] and through IP-in-IP tunnels [[RFC6040](#)]. These RFCs take a consistent approach and the following guidelines are designed to ensure this consistency continues as ECN support is added to other protocols that encapsulate IP. The guidelines are also designed to ensure compliance with the more general best current practice for the design of alternate ECN schemes given in [[RFC4774](#)].

The rest of this section is structured as follows:

- o [Section 5.1](#) addresses the most straightforward cases, where [[RFC6040](#)] can be applied directly to add ECN to tunnels that are effectively the same as IP-in-IP tunnels.
- o The subsequent sections give guidelines for adding ECN to a subnet technology that uses feed-forward-and-up mode like IP, but it is not so similar to IP that [[RFC6040](#)] rules can be applied directly. Specifically:
 - * Sections [5.2](#), [5.3](#) and [5.4](#) respectively address how to add ECN support to the wire protocol and to the encapsulators and decapsulators at the ingress and egress of the subnet.

- * [Section 5.5](#) deals with the special, but common, case of sequences of tunnels or subnets that all use the same technology
- * [Section 5.6](#) deals with the question of reframing when IP packets do not map 1:1 into lower layer frames.

[5.1.](#) IP-in-IP Tunnels with Tightly Coupled Shim Headers

A common pattern for many tunnelling protocols is to encapsulate an inner IP header with shim header(s) then an outer IP header. In many cases the shim header(s) and the outer IP header are always added (or removed) as part of the same process. We call this a tightly coupled shim header. Processing the shim and outer together is often necessary because the shim(s) are not sufficient for packet forwarding in their own right; not unless complemented by an outer header.

For all such tightly coupled shim headers (such as those listed in the Introduction), the rules in [[RFC6040](#)] for propagating the ECN field can be applied directly between the inner and outer IP headers. [[I-D.briscoe-tsvwg-rfc6040bis](#)] clarifies that [RFC 6040](#) is just as applicable when there is a tightly-coupled shim between two IP headers as when there is not.

[5.2.](#) Wire Protocol Design: Indication of ECN Support

This section is intended to guide the redesign of any lower layer protocol that encapsulate IP to add native ECN support at the lower layer. It reflects the approaches used in [[RFC6040](#)] and in [[RFC5129](#)]. Therefore IP-in-IP tunnels or IP-in-MPLS or MPLS-in-MPLS encapsulations that already comply with [[RFC6040](#)] or [[RFC5129](#)] will already satisfy this guidance.

A lower layer (or subnet) congestion notification system:

1. SHOULD NOT apply explicit congestion notifications to PDUs that are destined for legacy layer-4 transport implementations that will not understand ECN, and
2. SHOULD NOT apply explicit congestion notifications to PDUs if the egress of the subnet might not propagate congestion notifications onward into the higher layer.

We use the term ECN-PDUs for a PDU on a feedback loop that will propagate congestion notification properly because it meets both the above criteria. And a Not-ECN-PDU is a PDU on a feedback loop that does not meet both criteria, and will therefore not

propagate congestion notification properly. A corollary of the above is that a lower layer congestion notification protocol:

3. SHOULD be able to distinguish ECN-PDUs from Not-ECN-PDUs.

Note that there is no need for all interior nodes within a subnet to be able to mark congestion explicitly. A mix of ECN and drop signals from different nodes is fine. However, if any interior nodes might generate ECN markings, guideline 2 above says that all relevant egress node(s) SHOULD be able to propagate those markings up to the higher layer.

In IP, if the ECN field in each PDU is cleared to the Not-ECT (not ECN-capable transport) codepoint, it indicates that the L4 transport will not understand congestion markings. A congested buffer must not mark these Not-ECT PDUs, and therefore drops them instead.

The mechanism a lower layer uses to distinguish the ECN-capability of PDUs need not mimic that of IP. The above guidelines merely say that the lower layer system, as a whole, should achieve the same outcome. For instance, ECN-capable feedback loops might use PDUs that are identified by a particular set of labels or tags. Alternatively, logical link protocols that use flow state might determine whether a PDU can be congestion marked by checking for ECN-support in the flow state. Other protocols might depend on out-of-band control signals.

The per-domain checking of ECN support in MPLS [[RFC5129](#)] is a good example of a way to avoid sending congestion markings to transports that will not understand them, without using any header space in the subnet protocol.

In MPLS, header space is extremely limited, therefore [RFC5129](#) does not provide a field in the MPLS header to indicate whether the PDU is an ECN-PDU or a Not-ECN-PDU. Instead, interior nodes in a domain are allowed to set explicit congestion indications without checking whether the PDU is destined for a transport that will understand them. Nonetheless, this is made safe by requiring that the network operator upgrades all decapsulating edges of a whole domain at once, as soon as even one switch within the domain is configured to mark rather than drop during congestion. Therefore, any edge node that might decapsulate a packet will be capable of checking whether the higher layer transport is ECN-capable. When decapsulating a CE-marked packet, if the decapsulator discovers that the higher layer (inner header) indicates the transport is not ECN-capable, it drops the packet--effectively on behalf of the earlier congested node (see Decapsulation Guideline 1 in [Section 5.4](#)).

It was only appropriate to define such an incremental deployment strategy because MPLS is targeted solely at professional operators, who can be expected to ensure that a whole subnetwork is consistently configured. This strategy might not be appropriate for other link technologies targeted at zero-configuration deployment or deployment by the general public (e.g. Ethernet). For such 'plug-and-play' environments it will be necessary to invent a failsafe approach that ensures congestion markings will never fall into black holes, no matter how inconsistently a system is put together. Alternatively, congestion notification relying on correct system configuration could be confined to flavours of Ethernet intended only for professional network operators, such as IEEE 802.1ah Provider Backbone Bridges (PBB).

ECN support in TRILL [[I-D.eastlake-trill-ecn-support](#)] provides a good example of how to add ECN to a lower layer protocol without relying on careful and consistent operator configuration. TRILL provides an extension header word with space for flags of different categories depending on whether logic to understand the extension is critical. The congestion experienced marking has been defined as a 'critical ingress-to-egress' flag. So if a transit RBridge sets this flag and an egress RBridge does not have any logic to process it, it will drop it; which is the desired default action anyway. Therefore TRILL RBridges can be updated with support for ECN in no particular order and, at the egress of the TRILL campus, congestion notification will be propagated to IP as ECN whenever ECN logic has been implemented, and as drop otherwise.

QCN [[IEEE802.1Qau](#)] provides another example of how to indicate to lower layer devices that the end-points will not understand ECN. An operator can define certain 802.1p classes of service to indicate non-QCN frames and an ingress bridge is required to map arriving not-QCN-capable IP packets to one of these non-QCN 802.1p classes.

5.3. Encapsulation Guidelines

This section is intended to guide the redesign of any node that encapsulates IP with a lower layer header when adding native ECN support to the lower layer protocol. It reflects the approaches used in [[RFC6040](#)] and in [[RFC5129](#)]. Therefore IP-in-IP tunnels or IP-in-MPLS or MPLS-in-MPLS encapsulations that already comply with [[RFC6040](#)] or [[RFC5129](#)] will already satisfy this guidance.

1. Egress Capability Check: A subnet ingress needs to be sure that the corresponding egress of a subnet will propagate any congestion notification added to the outer header across the subnet. This is necessary in addition to checking that an

incoming PDU indicates an ECN-capable (L4) transport. Examples of how this guarantee might be provided include:

- * by configuration (e.g. if any label switches in a domain support ECN marking, [[RFC5129](#)] requires all egress nodes to have been configured to propagate ECN)
 - * by the ingress explicitly checking that the egress propagates ECN (e.g. TRILL uses IS-IS to check path capabilities before using critical options [[RFC7780](#)])
 - * by inherent design of the protocol (e.g. by encoding ECN marking on the outer header in such a way that a legacy egress that does not understand ECN will consider the PDU corrupt and discard it, thus at least propagating a form of congestion signal).
2. Egress Fails Capability Check: If the ingress cannot guarantee that the egress will propagate congestion notification, the ingress SHOULD disable ECN when it forwards the PDU at the lower layer. An example of how the ingress might disable ECN at the lower layer would be by setting the outer header of the PDU to identify it as a Not-ECN-PDU, assuming the subnet technology supports such a concept.
 3. Standard Congestion Monitoring Baseline: Once the ingress to a subnet has established that the egress will correctly propagate ECN, on encapsulation it SHOULD encode the same level of congestion in outer headers as is arriving in incoming headers. For example it might copy any incoming congestion notification into the outer header of the lower layer protocol.

This ensures that all outer headers reflect congestion accumulated along the whole upstream path since the Load Regulator, not just since the ingress of the subnet. A node that is not the Load Regulator SHOULD NOT re-initialise the level of CE markings in the outer to zero.

This guideline is intended to ensure that any bulk congestion monitoring of outer headers (e.g. by a network management node monitoring ECN in passing frames) is most meaningful. For instance, if an operator measures CE in 0.4% of passing outer headers, this information is only useful if the operator knows where the proportion of CE markings was last initialised to 0% (the Congestion Baseline). Such monitoring information will not be useful if some subnet ingress nodes reset all outer CE markings while others copy incoming CE markings into the outer.

Most information can be extracted if the Congestion Baseline is standardised at the node that is regulating the load (the Load Regulator--typically the data source). Then the operator can measure both congestion since the Load Regulator, and congestion since the subnet ingress. The latter might be measurable by subtracting the level of CE markings on inner headers from that on outer headers (see [Appendix C of \[RFC6040\]](#)).

5.4. Decapsulation Guidelines

This section is intended to guide the redesign of any node that decapsulates IP from within a lower layer header when adding native ECN support to the lower layer protocol. It reflects the approaches used in [\[RFC6040\]](#) and in [\[RFC5129\]](#). Therefore IP-in-IP tunnels or IP-in-MPLS or MPLS-in-MPLS encapsulations that already comply with [\[RFC6040\]](#) or [\[RFC5129\]](#) will already satisfy this guidance.

A subnet egress SHOULD NOT simply copy congestion notification from outer headers to the forwarded header. It SHOULD calculate the outgoing congestion notification field from the inner and outer headers using the following guidelines. If there is any conflict, rules earlier in the list take precedence over rules later in the list:

1. If the arriving inner header is a Not-ECN-PDU it implies the L4 transport will not understand explicit congestion markings.
Then:
 - * If the outer header carries an explicit congestion marking, drop is the only indication of congestion that the L4 transport will understand. If the congestion marking is the most severe possible, the packet MUST be dropped. However, if congestion can be marked with multiple levels severity and the packet's marking is not the most severe, the packet MAY be forwarded, but it SHOULD be dropped.
 - * If the outer is an ECN-PDU that carries no indication of congestion or a Not-ECN-PDU the PDU SHOULD be forwarded, but still as a Not-ECN-PDU.
2. If the outer header does not support explicit congestion notification (a Not-ECN-PDU), but the inner header does (an ECN-PDU), the inner header SHOULD be forwarded unchanged.
3. In some lower layer protocols congestion may be signalled as a numerical level, such as in the control frames of quantised congestion notification [\[IEEE802.1Qau\]](#). If such a multi-bit encoding encapsulates an ECN-capable IP data packet, a function

will be needed to convert the quantised congestion level into the frequency of congestion markings in outgoing IP packets.

4. Congestion indications may be encoded by a severity level. For instance increasing levels of congestion might be encoded by numerically increasing indications, e.g. pre-congestion notification (PCN) can be encoded in each PDU at three severity levels in IP or MPLS [[RFC6660](#)].

If the arriving inner header is an ECN-PDU, where the inner and outer headers carry indications of congestion of different severity, the more severe indication SHOULD be forwarded in preference to the less severe.

5. The inner and outer headers might carry a combination of congestion notification fields that should not be possible given any currently used protocol transitions. For instance, if Encapsulation Guideline 3 in [Section 5.3](#) had been followed, it should not be possible to have a less severe indication of congestion in the outer than in the inner. It MAY be appropriate to log unexpected combinations of headers and possibly raise an alarm.

If a safe outgoing codepoint can be defined for such a PDU, the PDU SHOULD be forwarded rather than dropped. Some implementers discard PDUs with currently unused combinations of headers just in case they represent an attack. However, an approach using alarms and policy-mediated drop is preferable to hard-coded drop, so that operators can keep track of possible attacks but currently unused combinations are not precluded from future use through new standards actions.

[5.5.](#) Sequences of Similar Tunnels or Subnets

In some deployments, particularly in 3GPP networks, an IP packet may traverse two or more IP-in-IP tunnels in sequence that all use identical technology (e.g. GTP).

In such cases, it would be sufficient for every encapsulation and decapsulation in the chain to comply with [RFC 6040](#). Alternatively, as an optimisation, a node that decapsulates a packet and immediately re-encapsulates it for the next tunnel MAY copy the incoming outer ECN field directly to the outgoing outer and the incoming inner ECN field directly to the outgoing inner. Then the overall behavior across the sequence of tunnel segments would still be consistent with [RFC 6040](#).

[Appendix C of RFC6040](#) describes how a tunnel egress can monitor how much congestion has been introduced within a tunnel. A network operator might want to monitor how much congestion had been introduced within a whole sequence of tunnels. Using the technique in [Appendix C of RFC6040](#) at the final egress, the operator could monitor the whole sequence of tunnels, but only if the above optimisation were used consistently along the sequence of tunnels, in order to make it appear as a single tunnel. Therefore, tunnel endpoint implementations SHOULD allow the operator to configure whether this optimisation is enabled.

When ECN support is added to a subnet technology, consideration SHOULD be given to a similar optimisation between subnets in sequence if they all use the same technology.

5.6. Reframing and Congestion Markings

The guidance in this section is worded in terms of framing boundaries, but it applies equally whether the protocol data units are frames, cells or packets.

Where framing boundaries are different between two layers, congestion indications SHOULD be propagated on the basis that a congestion indication on a PDU applies to all the octets in the PDU. On average, an encapsulator or decapsulator SHOULD approximately preserve the number of marked octets arriving and leaving (counting the size of inner headers, but not added encapsulating headers).

The next departing frame SHOULD be immediately marked even if only enough incoming marked octets have arrived for part of the departing frame. This ensures that any outstanding congestion marked octets are propagated immediately, rather than held back waiting for a frame no bigger than the outstanding marked octets--which might involve a long wait.

For instance, an algorithm for marking departing frames could maintain a counter representing the balance of arriving marked octets minus departing marked octets. It adds the size of every marked frame that arrives and if the counter is positive it marks the next frame to depart and subtracts its size from the counter. This will often leave a negative remainder in the counter, which is deliberate.

6. Feed-Up-and-Forward Mode: Guidelines for Adding Congestion Notification

The guidance in this section is applicable, for example, when IP packets:

- o are encapsulated in Ethernet headers, which have no support for ECN;
- o are forwarded by the eNode-B (base station) of a 3GPP radio access network, which is required to apply ECN marking during congestion, [[LTE-RA](#)], [[UTRAN](#)], but the Packet Data Convergence Protocol (PDCP) that encapsulates the IP header over the radio access has no support for ECN.

This guidance also generalises to encapsulation by other subnet technologies with no native support for explicit congestion notification at the lower layer, but with support for finding and processing an IP header. It is unlikely to be applicable or necessary for IP-in-IP encapsulation, where feed-forward-and-up mode based on [[RFC6040](#)] would be more appropriate.

Marking the IP header while switching at layer-2 (by using a layer-3 switch) or while forwarding in a radio access network seems to represent a layering violation. However, it can be considered as a benign optimisation if the guidelines below are followed. Feed-up-and-forward is certainly not a general alternative to implementing feed-forward congestion notification in the lower layer, because:

- o IPv4 and IPv6 are not the only layer-3 protocols that might be encapsulated by lower layer protocols
- o Link-layer encryption might be in use, making the layer-2 payload inaccessible
- o Many Ethernet switches do not have 'layer-3 switch' capabilities so they cannot read or modify an IP payload
- o It might be costly to find an IP header (v4 or v6) when it may be encapsulated by more than one lower layer header, e.g. Ethernet MAC in MAC [[IEEE802.1Qah](#)].

Nonetheless, configuring lower layer equipment to look for an ECN field in an encapsulated IP header is a useful optimisation. If the implementation follows the guidelines below, this optimisation does not have to be confined to a controlled environment such as within a data centre; it could usefully be applied on any network--even if the operator is not sure whether the above issues will never apply:

1. If a native lower-layer congestion notification mechanism exists for a subnet technology, it is safe to mix feed-up-and-forward with feed-forward-and-up on other switches in the same subnet. However, it will generally be more efficient to use the native mechanism.

2. The depth of the search for an IP header SHOULD be limited. If an IP header is not found soon enough, or an unrecognised or unreadable header is encountered, the switch SHOULD resort to an alternative means of signalling congestion (e.g. drop, or the native lower layer mechanism if available).
3. It is sufficient to use the first IP header found in the stack; the egress of the relevant tunnel can propagate congestion notification upwards to any more deeply encapsulated IP headers later.

7. Feed-Backward Mode: Guidelines for Adding Congestion Notification

It can be seen from [Section 4.3](#) that congestion notification in a subnet using feed-backward mode has generally not been designed to be directly coupled with IP layer congestion notification. The subnet attempts to minimise congestion internally, and if the incoming load at the ingress exceeds the capacity somewhere through the subnet, the layer 3 buffer into the ingress backs up. Thus, a feed-backward mode subnet is in some sense similar to a null mode subnet, in that there is no need for any direct interaction between the subnet and higher layer congestion notification. Therefore no detailed protocol design guidelines are appropriate. Nonetheless, a more general guideline is appropriate:

A subnetwork technology intended to eventually interface to IP SHOULD NOT be designed using only the feed-backward mode, which is certainly best for a stand-alone subnet, but would need to be modified to work efficiently as part of the wider Internet, because IP uses feed-forward-and-up mode.

The feed-backward approach at least works beneath IP, where the term 'works' is used only in a narrow functional sense because feed-backward can result in very inefficient and sluggish congestion control--except if it is confined to the subnet directly connected to the original data source, when it is faster than feed-forward. It would be valid to design a protocol that could work in feed-backward mode for paths that only cross one subnet, and in feed-forward-and-up mode for paths that cross subnets.

In the early days of TCP/IP, a similar feed-backward approach was tried for explicit congestion signalling, using source-quench (SQ) ICMP control packets. However, SQ fell out of favour and is now formally deprecated [[RFC6633](#)]. The main problem was that it is hard for a data source to tell the difference between a spoofed SQ message and a quench request from a genuine buffer on the path. It is also hard for a lower layer buffer to address an SQ message to the

original source port number, which may be buried within many layers of headers, and possibly encrypted.

Quantised congestion notification (QCN--also known as backward congestion notification or BCN) [[IEEE802.1Qau](#)] uses a feed-backward mode structurally similar to ATM's relative rate mechanism. However, QCN confines its applicability to scenarios such as some data centres where all endpoints are directly attached by the same Ethernet technology. If a QCN subnet were later connected into a wider IP-based internetwork (e.g. when attempting to interconnect multiple data centres) it would suffer the inefficiency shown Figure 3.

8. IANA Considerations (to be removed by RFC Editor)

This memo includes no request to IANA.

9. Security Considerations

If a lower layer wire protocol is redesigned to include explicit congestion signalling in-band in the protocol header, care SHOULD be taken to ensure that the field used is specified as mutable during transit. Otherwise interior nodes signalling congestion would invalidate any authentication protocol applied to the lower layer header--by altering a header field that had been assumed as immutable.

The redesign of protocols that encapsulate IP in order to propagate congestion signals between layers raises potential signal integrity concerns. Experimental or proposed approaches exist for assuring the end-to-end integrity of in-band congestion signals, e.g.:

- o Congestion exposure (ConEx) for networks to audit that their congestion signals are not being suppressed by other networks or by receivers, and for networks to police that senders are responding sufficiently to the signals, irrespective of the transport protocol used [[RFC7713](#)].
- o The ECN nonce [[RFC3540](#)] for a TCP sender to detect whether a network or the receiver is suppressing congestion signals.
- o A test with the same goals as the ECN nonce, but without the need for the receiver to co-operate with the protocol [[I-D.moncaster-tcpm-rcv-cheat](#)].

Given these end-to-end approaches are already being specified, it would make little sense to attempt to design hop-by-hop congestion signal integrity into a new lower layer protocol, because end-to-end integrity inherently achieves hop-by-hop integrity.

10. Conclusions

Following the guidance in the document enables ECN support to be extended to numerous protocols that encapsulate IP (v4 & v6) in a consistent way, so that IP continues to fulfil its role as an end-to-end interoperability layer. This includes:

- o A wide range of tunnelling protocols with various forms of shim header between two IP headers;
- o A wide range of subnet technologies, particularly those that work in the same 'feed-forward-and-up' mode that is used to support ECN in IP and MPLS.

Guidelines have been defined for supporting propagation of ECN between Ethernet and IP on so-called Layer-3 Ethernet switches, using a 'feed-up-an-forward' mode. This approach could enable other subnet technologies to pass ECN signals into the IP layer, even if they do not support ECN natively.

Finally, attempting to add ECN to a subnet technology in feed-backward mode is deprecated except in special cases, due to its likely sluggish response to congestion.

11. Acknowledgements

Thanks to Gorry Fairhurst for extensive reviews. Thanks also to the following reviewers: Richard Scheffenegger, Ingemar Johansson, Piers O'Hanlon and Michael Welzl, who pointed out that lower layer congestion notification signals may have different semantics to those in IP.

Bob Briscoe was part-funded by the European Community under its Seventh Framework Programme through the Trilogy project (ICT-216372) for initial drafts and through the Reducing Internet Transport Latency (RITE) project (ICT-317700) subsequently. The views expressed here are solely those of the authors.

12. Comments Solicited

Comments and questions are encouraged and very welcome. They can be addressed to the IETF Transport Area working group mailing list <tsvwg@ietf.org>, and/or to the authors.

13. References

13.1. Normative References

- [RFC2119] Bradner, S., "Key words for use in RFCs to Indicate Requirement Levels", [BCP 14](#), [RFC 2119](#), DOI 10.17487/RFC2119, March 1997, <<http://www.rfc-editor.org/info/rfc2119>>.
- [RFC3168] Ramakrishnan, K., Floyd, S., and D. Black, "The Addition of Explicit Congestion Notification (ECN) to IP", [RFC 3168](#), DOI 10.17487/RFC3168, September 2001, <<http://www.rfc-editor.org/info/rfc3168>>.
- [RFC3819] Karn, P., Ed., Bormann, C., Fairhurst, G., Grossman, D., Ludwig, R., Mahdavi, J., Montenegro, G., Touch, J., and L. Wood, "Advice for Internet Subnetwork Designers", [BCP 89](#), [RFC 3819](#), DOI 10.17487/RFC3819, July 2004, <<http://www.rfc-editor.org/info/rfc3819>>.
- [RFC4774] Floyd, S., "Specifying Alternate Semantics for the Explicit Congestion Notification (ECN) Field", [BCP 124](#), [RFC 4774](#), DOI 10.17487/RFC4774, November 2006, <<http://www.rfc-editor.org/info/rfc4774>>.
- [RFC5129] Davie, B., Briscoe, B., and J. Tay, "Explicit Congestion Marking in MPLS", [RFC 5129](#), DOI 10.17487/RFC5129, January 2008, <<http://www.rfc-editor.org/info/rfc5129>>.
- [RFC6040] Briscoe, B., "Tunnelling of Explicit Congestion Notification", [RFC 6040](#), DOI 10.17487/RFC6040, November 2010, <<http://www.rfc-editor.org/info/rfc6040>>.

13.2. Informative References

- [ATM-TM-ABR] Cisco, "Understanding the Available Bit Rate (ABR) Service Category for ATM VCs", Design Technote 10415, June 2005.
- [Buck00] Buckwalter, J., "Frame Relay: Technology and Practice", Pub. Addison Wesley ISBN-13: 978-0201485240, 2000.
- [DCTCP] Alizadeh, M., Greenberg, A., Maltz, D., Padhye, J., Patel, P., Prabhakar, B., Sengupta, S., and M. Sridharan, "Data Center TCP (DCTCP)", ACM SIGCOMM CCR 40(4)63--74, October 2010, <<http://portal.acm.org/citation.cfm?id=1851192>>.

- [GTPv1] 3GPP, "GPRS Tunnelling Protocol (GTP) across the Gn and Gp interface", Technical Specification TS 29.060.
- [GTPv1-U] 3GPP, "General Packet Radio System (GPRS) Tunnelling Protocol User Plane (GTPv1-U)", Technical Specification TS 29.281.
- [GTPv2-C] 3GPP, "Evolved General Packet Radio Service (GPRS) Tunnelling Protocol for Control plane (GTPv2-C)", Technical Specification TS 29.274.
- [I-D.briscoe-tsvwg-rfc6040bis]
Briscoe, B., "Propagating Explicit Congestion Notification Across IP Tunnel Headers Separated by a Shim", [draft-briscoe-tsvwg-rfc6040bis-00](#) (work in progress), July 2016.
- [I-D.eastlake-trill-ecn-support]
Eastlake, D. and B. Briscoe, "TRILL: ECN (Explicit Congestion Notification) Support", [draft-eastlake-trill-ecn-support-00](#) (work in progress), March 2016.
- [I-D.ietf-nvo3-geneve]
Gross, J. and I. Ganga, "Geneve: Generic Network Virtualization Encapsulation", [draft-ietf-nvo3-geneve-01](#) (work in progress), January 2016.
- [I-D.ietf-nvo3-gue]
Herbert, T., Yong, L., and O. Zia, "Generic UDP Encapsulation", [draft-ietf-nvo3-gue-04](#) (work in progress), July 2016.
- [I-D.ietf-tsvwg-circuit-breaker]
Fairhurst, G., "Network Transport Circuit Breakers", [draft-ietf-tsvwg-circuit-breaker-15](#) (work in progress), April 2016.
- [I-D.moncaster-tcpm-rcv-cheat]
Moncaster, T., Briscoe, B., and A. Jacquet, "A TCP Test to Allow Senders to Identify Receiver Non-Compliance", [draft-moncaster-tcpm-rcv-cheat-03](#) (work in progress), July 2014.
- [IEEE802.1Qah]
IEEE, "IEEE Standard for Local and Metropolitan Area Networks--Virtual Bridged Local Area Networks--Amendment 6: Provider Backbone Bridges", IEEE Std 802.1Qah-2008, August 2008,
<<http://www.ieee802.org/1/pages/802.1ah.html>>.

(Access Controlled link within page)

[IEEE802.1Qau]

Finn, N., Ed., "IEEE Standard for Local and Metropolitan Area Networks--Virtual Bridged Local Area Networks - Amendment 13: Congestion Notification", IEEE Std 802.1Qau-2010, March 2010, <<http://ieeexplore.ieee.org/xpl/mostRecentIssue.jsp?punumber=5454061>>.

(Access Controlled link within page)

[ITU-T.I.371]

ITU-T, "Traffic Control and Congestion Control in B-ISDN", ITU-T Rec. I.371 (03/04), March 2004, <<http://ieeexplore.ieee.org/xpl/mostRecentIssue.jsp?punumber=5454061>>.

[LTE-RA] 3GPP, "Evolved Universal Terrestrial Radio Access (E-UTRA) and Evolved Universal Terrestrial Radio Access Network (E-UTRAN); Overall description; Stage 2", Technical Specification TS 36.300.

[RFC1323] Jacobson, V., Braden, R., and D. Borman, "TCP Extensions for High Performance", [RFC 1323](#), DOI 10.17487/RFC1323, May 1992, <<http://www.rfc-editor.org/info/rfc1323>>.

[RFC1701] Hanks, S., Li, T., Farinacci, D., and P. Traina, "Generic Routing Encapsulation (GRE)", [RFC 1701](#), DOI 10.17487/RFC1701, October 1994, <<http://www.rfc-editor.org/info/rfc1701>>.

[RFC2003] Perkins, C., "IP Encapsulation within IP", [RFC 2003](#), DOI 10.17487/RFC2003, October 1996, <<http://www.rfc-editor.org/info/rfc2003>>.

[RFC2637] Hamzeh, K., Pall, G., Verthein, W., Taarud, J., Little, W., and G. Zorn, "Point-to-Point Tunneling Protocol (PPTP)", [RFC 2637](#), DOI 10.17487/RFC2637, July 1999, <<http://www.rfc-editor.org/info/rfc2637>>.

[RFC2661] Townsley, W., Valencia, A., Rubens, A., Pall, G., Zorn, G., and B. Palter, "Layer Two Tunneling Protocol "L2TP"", [RFC 2661](#), DOI 10.17487/RFC2661, August 1999, <<http://www.rfc-editor.org/info/rfc2661>>.

- [RFC2784] Farinacci, D., Li, T., Hanks, S., Meyer, D., and P. Traina, "Generic Routing Encapsulation (GRE)", [RFC 2784](#), DOI 10.17487/RFC2784, March 2000, <<http://www.rfc-editor.org/info/rfc2784>>.
- [RFC2884] Hadi Salim, J. and U. Ahmed, "Performance Evaluation of Explicit Congestion Notification (ECN) in IP Networks", [RFC 2884](#), DOI 10.17487/RFC2884, July 2000, <<http://www.rfc-editor.org/info/rfc2884>>.
- [RFC2983] Black, D., "Differentiated Services and Tunnels", [RFC 2983](#), DOI 10.17487/RFC2983, October 2000, <<http://www.rfc-editor.org/info/rfc2983>>.
- [RFC3540] Spring, N., Wetherall, D., and D. Ely, "Robust Explicit Congestion Notification (ECN) Signaling with Nonces", [RFC 3540](#), DOI 10.17487/RFC3540, June 2003, <<http://www.rfc-editor.org/info/rfc3540>>.
- [RFC4301] Kent, S. and K. Seo, "Security Architecture for the Internet Protocol", [RFC 4301](#), DOI 10.17487/RFC4301, December 2005, <<http://www.rfc-editor.org/info/rfc4301>>.
- [RFC6633] Gont, F., "Deprecation of ICMP Source Quench Messages", [RFC 6633](#), DOI 10.17487/RFC6633, May 2012, <<http://www.rfc-editor.org/info/rfc6633>>.
- [RFC6660] Briscoe, B., Moncaster, T., and M. Menth, "Encoding Three Pre-Congestion Notification (PCN) States in the IP Header Using a Single Diffserv Codepoint (DSCP)", [RFC 6660](#), DOI 10.17487/RFC6660, July 2012, <<http://www.rfc-editor.org/info/rfc6660>>.
- [RFC7348] Mahalingam, M., Dutt, D., Duda, K., Agarwal, P., Kreeger, L., Sridhar, T., Bursell, M., and C. Wright, "Virtual eXtensible Local Area Network (VXLAN): A Framework for Overlaying Virtualized Layer 2 Networks over Layer 3 Networks", [RFC 7348](#), DOI 10.17487/RFC7348, August 2014, <<http://www.rfc-editor.org/info/rfc7348>>.
- [RFC7567] Baker, F., Ed. and G. Fairhurst, Ed., "IETF Recommendations Regarding Active Queue Management", [BCP 197](#), [RFC 7567](#), DOI 10.17487/RFC7567, July 2015, <<http://www.rfc-editor.org/info/rfc7567>>.

- [RFC7713] Mathis, M. and B. Briscoe, "Congestion Exposure (ConEx) Concepts, Abstract Mechanism, and Requirements", [RFC 7713](#), DOI 10.17487/RFC7713, December 2015, <<http://www.rfc-editor.org/info/rfc7713>>.
- [RFC7780] Eastlake 3rd, D., Zhang, M., Perlman, R., Banerjee, A., Ghanwani, A., and S. Gupta, "Transparent Interconnection of Lots of Links (TRILL): Clarifications, Corrections, and Updates", [RFC 7780](#), DOI 10.17487/RFC7780, February 2016, <<http://www.rfc-editor.org/info/rfc7780>>.
- [UTRAN] 3GPP, "UTRAN Overall Description", Technical Specification TS 25.401.

[Appendix A](#). Outstanding Document Issues

1. [GF] Concern that certain guidelines warrant a MUST (NOT) rather than a SHOULD (NOT). Given the guidelines say that if any SHOULD (NOT)s are not followed, a strong justification will be needed, they have been left as SHOULD (NOT) pending further list discussion. In particular:

- * If inner is a Not-ECN-PDU and Outer is CE (or highest severity congestion level), MUST (not SHOULD) drop?

This issue has been addressed by explaining when SHOULD or MUST is appropriate.

2. Consider whether an IETF Standard Track doc will be needed to Update the IP-in-IP protocols listed in [Section 5.1](#)--at least those that the IETF controls--and which Area it should sit under.

This issue has been addressed by the production of [\[I-D.briscoe-tsvwg-rfc6040bis\]](#), but this text is left outstanding until that draft is adopted.

[Appendix B](#). Changes in This Version (to be removed by RFC Editor)

From ietf-05 to ietf-06:

- * Introduction: Added GUE and Geneve as examples of tightly coupled shims between IP headers that cite [RFC 6040](#). And added VXLAN to list of those that do not.
- * Replaced normative text about tightly coupled shims between IP headers, with reference to new [draft-briscoe-tsvwg-rfc6040bis](#)
- * Wire Protocol Design: Indication of ECN Support: Added TRILL as an example of a well-design protocol that does not need an indication of ECN support in the wire protocol.
- * Encapsulation Guidelines: In the case of a Not-ECN-PDU with a CE outer, replaced SHOULD be dropped, with explanations of when SHOULD or MUST are appropriate.
- * Feed-Up-and-Forward Mode: Explained examples more carefully, referred to PDCP and cited UTRAN spec as well as E-UTRAN.
- * Updated references.
- * Marked open issues as resolved, but did not delete Open Issues Appendix (yet).

From ietf-04 to ietf-05:

- * Explained why tightly coupled shim headers only "SHOULD" comply with [RFC 6040](#), not "MUST".
- * Updated references

From ietf-03 to ietf-04:

- * Addressed Richard Scheffenegger's review comments: primarily editorial corrections, and addition of examples for clarity.

From ietf-02 to ietf-03:

- * Updated references, ad cited [RFC4774](#).

From ietf-01 to ietf-02:

- * Added Section for guidelines that are applicable in all cases.
- * Updated references.

From ietf-00 to ietf-01: Updated references.

From briscoe-04 to ietf-00: Changed filename following tsvwg adoption.

From briscoe-03 to 04:

- * Re-arranged the introduction to describe the purpose of the document first before introducing ECN in more depth. And clarified the introduction throughout.
- * Added applicability to 3GPP TS 36.300.

From briscoe-02 to 03:

- * Scope section:
 - + Added dependence on correct propagation of traffic class information
 - + For the feed-backward mode, deemed multicast and anycast out of scope
- * Ensured all guidelines referring to subnet technologies also refer to tunnels and vice versa by adding applicability

sentences at the start of sections [4.1](#), [4.2](#), [4.3](#), [4.4](#), [4.6](#) and 5.

- * Added Security Considerations on ensuring congestion signal fields are classed as immutable and on using end-to-end congestion signal integrity technologies rather than hop-by-hop.

From briscoe-01 to 02:

- * Added authors: JK & PT
- * Added
 - + [Section 4.1](#) "IP-in-IP Tunnels with Tightly Coupled Shim Headers"
 - + [Section 4.5](#) "Sequences of Similar Tunnels or Subnets"
 - + roadmap at the start of [Section 4](#), given the subsections have become quite fragmented.
 - + [Section 9](#) "Conclusions"
- * Clarified why transports are starting to be able to saturate interior links
- * Under [Section 1.1](#), addressed the question of alternative signal semantics and included multicast & anycast.
- * Under [Section 3.1](#), included a 3GPP example.
- * [Section 4.2](#). "Wire Protocol Design":
 - + Altered guideline 2. to make it clear that it only applies to the immediate subnet egress, not later ones
 - + Added a reminder that it is only necessary to check that ECN propagates at the egress, not whether interior nodes mark ECN
 - + Added example of how QCN uses 802.1p to indicate support for QCN.
- * Added references to [Appendix C of RFC6040](#), about monitoring the amount of congestion signals introduced within a tunnel

- * [Appendix A](#): Added more issues to be addressed, including plan to produce a standards track update to IP-in-IP tunnel protocols.
- * Updated acks and references

From briscoe-00 to 01:

- * Intended status: BCP (was Informational) & updates 3819 added.
- * Briefer Introduction: Introductory para justifying benefits of ECN. Moved all but a brief enumeration of modes of operation to their own new section (from both Intro & Scope). Introduced incr. deployment as most tricky part.
- * Tightened & added to terminology section
- * Structured with Modes of Operation, then Guidelines section for each mode.
- * Tightened up guideline text to remove vagueness / passive voice / ambiguity and highlight main guidelines as numbered items.
- * Added Outstanding Document Issues Appendix
- * Updated references

Authors' Addresses

Bob Briscoe
Simula Research Laboratory
UK

EEmail: ietf@bobbriscoe.net
URI: <http://bobbriscoe.net/>

John Kaippallimalil
Huawei
5340 Legacy Drive, Suite 175
Plano, Texas 75024
USA

EEmail: john.kaippallimalil@huawei.com

Pat Thaler
Broadcom Corporation
5025 Keane Drive
Carmichael, CA 95608
USA

EMail: pthaler@broadcom.com