

TRILL
Internet Draft
Intended status: Standards Track

Tissa Senevirathne
Norman Finn
Deepak Kumar
Samer Salam
Cisco

Liang Xia
Weiguo Hao
Huawei

June 10, 2014

Expires: December 2014

YANG Data Model for TRILL Operations, Administration, and
Maintenance (OAM)
draft-tissa-trill-yang-oam-00.txt

Status of this Memo

This Internet-Draft is submitted in full conformance with the provisions of [BCP 78](#) and [BCP 79](#).

Internet-Drafts are working documents of the Internet Engineering Task Force (IETF), its areas, and its working groups. Note that other groups may also distribute working documents as Internet-Drafts.

Internet-Drafts are draft documents valid for a maximum of six months and may be updated, replaced, or obsoleted by other documents at any time. It is inappropriate to use Internet-Drafts as reference material or to cite them other than as "work in progress."

The list of current Internet-Drafts can be accessed at <http://www.ietf.org/ietf/lid-abstracts.txt>

The list of Internet-Draft Shadow Directories can be accessed at <http://www.ietf.org/shadow.html>

This Internet-Draft will expire on December 10, 2014.

Copyright Notice

Copyright (c) 2014 IETF Trust and the persons identified as the document authors. All rights reserved.

This document is subject to [BCP 78](http://trustee.ietf.org/license-info) and the IETF Trust's Legal Provisions Relating to IETF Documents (<http://trustee.ietf.org/license-info>) in effect on the date of publication of this document. Please review these documents carefully, as they describe your rights and restrictions with respect to this document. Code Components extracted from this document must include Simplified BSD License text as described in Section 4.e of the Trust Legal Provisions and are provided without warranty as described in the Simplified BSD License.

Abstract

This document presents YANG Data model for TRILL OAM. It extends the Generic YANG model for OAM defined in [[GENYANGOAM](#)] with TRILL technology specifics.

Table of Contents

- [1](#). Introduction.....[2](#)
- [2](#). Conventions used in this document.....[3](#)
 - [2.1](#). Terminology.....[3](#)
- [3](#). Architecture of OAM YANG Model and Relationship to TRILL OAM...[3](#)
- [4](#). TRILL extensions to Generic YANG Model.....[4](#)
 - [4.1](#). MEP address.....[4](#)
 - [4.2](#). Flow-entropy.....[5](#)
 - [4.3](#). Context-id.....[5](#)
 - [4.4](#). rpc definitions.....[6](#)
- [5](#). OAM data hierarchy.....[6](#)
- [6](#). OAM YANG module.....[12](#)
- [7](#). Base Mode for TRILL OAM.....[20](#)
- [8](#). Security Considerations.....[20](#)
- [9](#). IANA Considerations.....[20](#)
- [10](#). References.....[21](#)
 - [10.1](#). Normative References.....[21](#)
 - [10.2](#). Informative References.....[21](#)
- [11](#). Acknowledgments.....[21](#)

[1](#). Introduction

Fault Management for TRILL is defined in [[TRILLOAMFM](#)]. TRILL Fault Management utilizes the [[8021Q](#)] CFM model and extends CFM with technology specific details. Those technology specific extensions are

flow-entropy for multipath support, MEP addressing on TRILL identifiers, and so on. The extensions are explained in detail in [TRILLOAMFM]. In this document, we extend the YANG model defined in [GENYANGOAM] with TRILL OAM specifics.

2. Conventions used in this document

The key words "MUST", "MUST NOT", "REQUIRED", "SHALL", "SHALL NOT", "SHOULD", "SHOULD NOT", "RECOMMENDED", "MAY", and "OPTIONAL" in this document are to be interpreted as described in [RFC-2119](#) [[RFC2119](#)].

In this document, these words will appear with that interpretation only when in ALL CAPS. Lower case uses of these words are not to be interpreted as carrying [RFC-2119](#) significance.

2.1. Terminology

CCM - Continuity Check Message [[80210](#)]

ECMP - Equal Cost Multipath

LBM - Loopback Message [[80210](#)]

MP - Maintenance Point [[80210](#)]

MEP - Maintenance End Point [[TRLOAMFRM](#)] [[80210](#)] [[RFC6371](#)]

MIP - Maintenance Intermediate Point [[TRLOAMFRM](#)] [[80210](#)] [[RFC6371](#)]

MA - Maintenance Association [[80210](#)] [[TRLOAMFRM](#)]

MD - Maintenance Domain [[80210](#)]

MTV - Multi-destination Tree Verification Message

OAM - Operations, Administration, and Maintenance [[RFC6291](#)]

TRILL - Transparent Interconnection of Lots of Links [[RFC6325](#)]

3. Architecture of OAM YANG Model and Relationship to TRILL OAM

The Generic OAM YANG model acts as the basis for other OAM YANG models. This allows users to traverse between OAM tools of different

technologies at ease through a uniform API set. This is also referred as the nested OAM workflow. The following Figure depicts the relationship of TRILL OAM YANG model to Generic YANG Model.

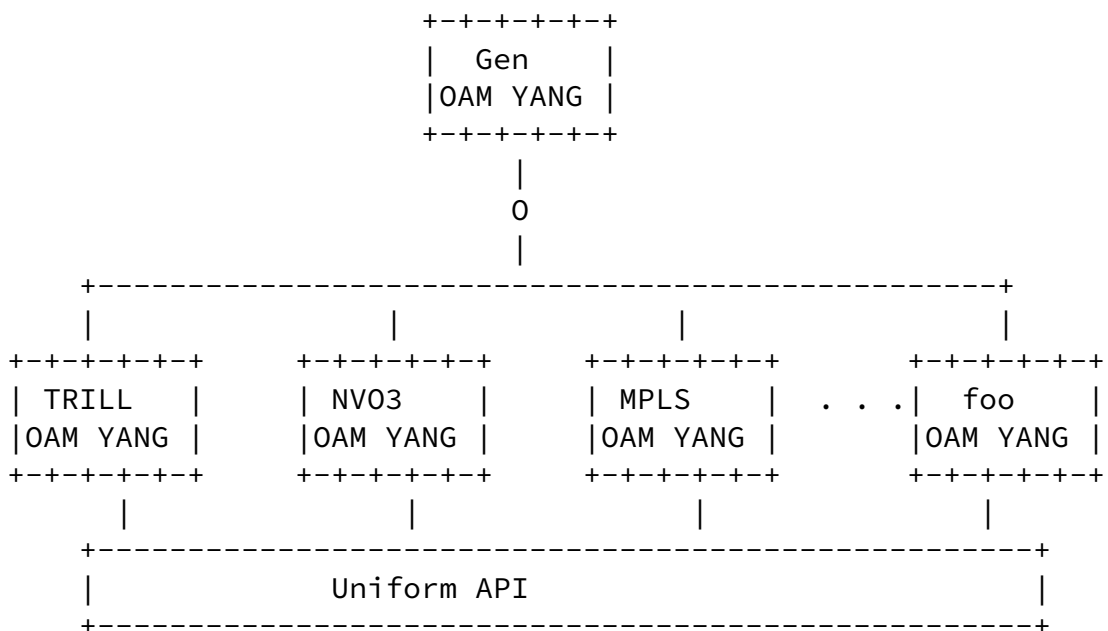

Figure 1 Relationship of TRILL OAM YANG model to Generic OAM YANG model

4. TRILL extensions to Generic YANG Model

The Technology parameter is defined in the [\[GENYANGOAM\]](#) as an identity. This allows easy extension of the YANG model by other technologies. Technology-specific extensions are applied only when the Technology parameter is set to the specific type. "trill" is defined as an identity that augments the base "technology-types".

```
identity trill {
```

```

    base goam:technology-types;
    description
      "trill type";
  }

```

Figure 2 Trill identity type.

[4.1.](#) MEP address

In TRILL, the MEP address is the 2 octet RBridge Nickname. In [\[GENYANGOAM\]](#) MEP address is defined as a combination choice and case statement. We augment this to include TRILL RBridge nickname.

```

augment
"/goam:domains/goam:domain/goam:MAS/goam:MA/goam:MEP/goam:mep-
address" {
  case mep-address-trill {
    leaf mep-address-trill {
      when "/goam:domains/goam:domain/goam:technology='trill'";
      type trill-rb-nickname;
    }
  }
}

```

Figure 3 Augment MEP address

[4.2.](#) Flow-entropy

In TRILL, flow-entropy is defined as a 96 octet field. [\[GENYANGOAM\]](#) defines a placeholder for flow-entropy. This allows other technologies to easily augment that to include technology-specific augmentations. Below figure depicts an example of augmenting flow-entropy to include TRILL flow-entropy.

```

augment "/goam:domains/goam:domain/goam:MAS/goam:MA/goam:flow-
entropy" {
  case flow-entropy-trill {
    leaf flow-entropy-trill {
      type flow-entropy-trill;
    }
  }
}

```

```
}
```

Figure 4 TRILL flow-entropy

[4.3.](#) Context-id

In TRILL, context-id is either 12 bit VLAN identifier or 24 bit fine-grained label. [[GENYANGOAM](#)] defines a placeholder for context-id. This allows other technologies to easily augment that to include technology specific extensions. The snippet below depicts an example of augmenting context-id to include the TRILL context-id.

```
augment
"/goam:domains/goam:domain/goam:MA/goam:MA/goam:MEP/goam:context-id"
{
  case context-id-vlan {
    leaf context-id-vlan {
      type vlan;
    }
  }
  case context-id-fgl {
    leaf context-id-fgl {
      type fgl;
    }
  }
}
```

Figure 5 TRILL context-id

[4.4.](#) rpc definitions

The rpc model facilitates issuing commands to a NETCONF server (in this case to the device that needs to execute the OAM command) and

obtaining a response. Grouping statement `command-ext-trill` defines the input extensions for TRILL.

Multicast Tree Verification (MTV) [TRILLOAMFM] rpc command, defined in TRILL YANG model, is TRILL specific and allows to verify connectivity as well as data-plane and control-plane integrity of TRILL multicast forwarding.

5. OAM data hierarchy

The complete data hierarchy related to the OAM YANG model is presented below. The following notations are used within the data tree and carry the meaning as noted below.

Each node is printed as:

```
<status> <flags> <name> <opts> <type>
```

<status> is one of:

- + for current
- x for deprecated
- o for obsolete

<flags> is one of:

- rw for configuration data
- ro for non-configuration data
- x for rpcs
- n for notifications

<name> is the name of the node

If the node is augmented into the tree from another module, its name is printed as <prefix>:<name>.

<opts> is one of:

- ? for an optional leaf or choice
- ! for a presence container

* for a leaf-list or list
[<keys>] for a list's keys

<type> is the name of the type for leafs and leaf-lists

```
module: trill-oam
augment /goam:domains/goam:domain/goam:MAS/goam:MA/goam:MEP/goam:mep-
address:
  +--:(mep-address-trill)
    +--rw mep-address-trill?   tril-rb-nickname
augment /goam:domains/goam:domain/goam:MAS/goam:MA/goam:context-id:
  +--:(context-id-vlan)
  | +--rw context-id-vlan?   vlan
  +--:(context-id-fgl)
    +--rw context-id-fgl?   fgl
augment /goam:domains/goam:domain/goam:MAS/goam:MA/goam:flow-entropy:
  +--:(flow-entropy-trill)
    +--rw flow-entropy-trill?   flow-entropy-trill
augment
/goam:domains/goam:domain/goam:MAS/goam:MA/goam:MEP/goam:context-id:
```



```

    +--:(context-id-vlan)
      | +--rw context-id-vlan?   vlan
    +--:(context-id-fgl)
      +--rw context-id-fgl?     fgl
augment
/goam:domains/goam:domain/goam:MAAs/goam:MA/goam:MEP/goam:flow-
entropy:
  +--:(flow-entropy-trill)
    +--rw flow-entropy-trill?   flow-entropy-trill
augment
/goam:domains/goam:domain/goam:MAAs/goam:MA/goam:MEP/goam:session/goam
:context-id:
  +--:(context-id-vlan)
    | +--rw context-id-vlan?   vlan
  +--:(context-id-fgl)
    +--rw context-id-fgl?     fgl
augment
/goam:domains/goam:domain/goam:MAAs/goam:MA/goam:MEP/goam:session/goam
:flow-entropy:
  +--:(flow-entropy-trill)
    +--rw flow-entropy-trill?   flow-entropy-trill
augment /goam:ping/goam:input:
  +--ro (out-of-band)?
  | +--:(ipv4-address)
  | | +--ro ipv4-address?      inet:ipv4-address
  | +--:(ipv6-address)
  | | +--ro ipv6-address?      inet:ipv6-address
  | +--:(trill-nickname)
  |   +--ro trill-nickname?     trill-nickname
  +--ro diagnostic-vlan?   boolean
augment /goam:ping/goam:input/goam:context-id:

```

```

    +--:(context-id-vlan)
      | +--ro context-id-vlan?   vlan
    +--:(context-id-fgl)
      +--ro context-id-fgl?     fgl
augment /goam:ping/goam:input/goam:flow-entropy:
  +--:(flow-entropy-trill)
    +--ro flow-entropy-trill?   flow-entropy-trill
augment /goam:ping/goam:input/goam:source-mep/goam:mep-address:
  +--:(trill-nickname)
    +--ro trill-nickname?     trill-nickname
augment /goam:ping/goam:input/goam:destination-mep/goam:mep-address:

```

```

    +---:(trill-nickname)
      +--ro trill-nickname?   tril-rb-nickname
augment /goam:ping/goam:output:
  +--ro upstream-rbridge?   tril-rb-nickname
  +--ro next-hop-rbridge*   tril-rb-nickname
augment /goam:trace-route/goam:input:
  +--ro (out-of-band)?
  | +---:(ipv4-address)
  | | +--ro ipv4-address?   inet:ipv4-address
  | +---:(ipv6-address)
  | | +--ro ipv6-address?   inet:ipv6-address
  | +---:(trill-nickname)
  |   +--ro trill-nickname?   tril-rb-nickname
  +--ro diagnostic-vlan?   boolean
augment /goam:trace-route/goam:input/goam:context-id:
  +---:(context-id-vlan)
  | +--ro context-id-vlan?   vlan
  +---:(context-id-fgl)
  | +--ro context-id-fgl?   fgl
augment /goam:trace-route/goam:input/goam:flow-entropy:
  +---:(flow-entropy-trill)
  | +--ro flow-entropy-trill?   flow-entropy-trill
augment /goam:trace-route/goam:input/goam:source-mep/goam:mep-
address:
  +---:(trill-nickname)
  | +--ro trill-nickname?   tril-rb-nickname
augment /goam:trace-route/goam:input/goam:destination-mep/goam:mep-
address:
  +---:(trill-nickname)
  | +--ro trill-nickname?   tril-rb-nickname
augment /goam:trace-route/goam:output/goam:response/goam:destination-
mep/goam:mep-address:
  +---:(trill-nickname)
  | +--ro trill-nickname?   tril-rb-nickname
augment /goam:trace-route/goam:output/goam:response:
  +--ro upstream-rbridge?   tril-rb-nickname

```

```

  +--ro next-hop-rbridge*   tril-rb-nickname
rpcs:
  +---x mtv
    +--ro input
      | +--ro technology           identityref
      | +--ro md-name-format       MD-name-format

```

```

| +---ro md-name?                binary
| +---ro md-level                int32
| +---ro ma-name-format          MA-name-format
| +---ro ma-name                 binary
| +---ro (out-of-band)?
| | +---:(ipv4-address)
| | | +---ro ipv4-address?      inet:ipv4-address
| | +---:(ipv6-address)
| | | +---ro ipv6-address?      inet:ipv6-address
| | +---:(trill-nickname)
| | | +---ro trill-nickname?    trill-rb-nickname
| +---ro diagnostic-vlan?        boolean
| +---ro (context-id)?
| | +---:(context-id-vlan)
| | | +---ro context-id-vlan?   vlan
| | +---:(context-id-fgl)
| | | +---ro context-id-fgl?    fgl
| +---ro (flow-entropy)?
| | +---:(flow-entropy-null)
| | | +---ro flow-entropy-null? empty
| | +---:(flow-entropy-trill)
| | | +---ro flow-entropy-trill? flow-entropy-trill
| +---ro max-hop-count?          uint8
| +---ro type?                   identityref
| +---ro scope*                  trill-rb-nickname
| +---ro ecmp-choice?            goam:ecmp-choices
| +---ro outgoing-interfaces* [interface]
| | +---ro interface            if:interface-ref
| +---ro source-mep
| | +---ro (mep-address)?
| | | +---:(mac-address)
| | | | +---ro mac-address?     yang:mac-address
| | | +---:(ipv4-address)
| | | | +---ro ipv4-address?    inet:ipv4-address
| | | +---:(ipv6-address)
| | | | +---ro ipv6-address?    inet:ipv6-address
| | +---ro mep-id?              goam:MEP-id
| +---ro destination-mep
| | +---ro (mep-address)?
| | | +---:(mac-address)
| | | | +---ro mac-address?     yang:mac-address

```

```

| | +---:(ipv4-address)

```

```

|      | | +--ro ipv4-address?  inet:ipv4-address
|      | | +--:(ipv6-address)
|      | | +--ro ipv6-address?  inet:ipv6-address
|      +--ro mep-id?             goam:MEP-id
+--ro output
  +--ro response* [mep-address mep-id]
    +--ro hop-count?             uint8
    +--ro mep-id                 goam:MEP-id
    +--ro mep-address            tril-rb-nickname
    +--ro next-hop-rbridge*      tril-rb-nickname
    +--ro upstream-rbridge?     tril-rb-nickname
    +--ro multicast-receiver-count? uint32
    +--ro tx-packet-count?      oam-counter32
    +--ro rx-packet-count?      oam-counter32
    +--ro min-delay?            oam-counter32
    +--ro average-delay?        oam-counter32
    +--ro max-delay?            oam-counter32

```

Figure 1 Data hierarchy of TRILL OAM

6. OAM YANG module

```
<CODE BEGINS> file "xxx.yang"

module trill-oam {
  namespace "urn:cisco:params:xml:ns:yang:tril-oam";
  prefix trilloam;

  import gen-oam {
    prefix goam;
  }
  import ietf-inet-types {
    prefix inet;
  }
  import ietf-interfaces {
    prefix if;
  }

  revision 2014-04-16 {
    description
      "Initial revision.";
  }

  identity trill {
    base goam:technology-types;
    description
      "trill type";
  }

  typedef tril-rb-nickname {
    type uint16;
  }

  typedef flow-entropy-trill {
    type binary {
      length "1..96";
    }
  }

  typedef vlan {
    type uint16 {
      range "0..4095";
    }
  }

  typedef fgl {
    type uint32;
```

```
}

identity trill-mtv {
  base goam:command-sub-type;
  description
    "identifies this command as multicast tree verification comand";
}

identity trill-ping {
  base goam:command-sub-type;
}

identity trill-trace-route {
  base goam:command-sub-type;
}

grouping command-ext-trill {
  description
    "group the rpc command extensions for trill";
  choice out-of-band {
    case ipv4-address {
      leaf ipv4-address {
        type inet:ipv4-address;
      }
    }
    case ipv6-address {
      leaf ipv6-address {
        type inet:ipv6-address;
      }
    }
    case trill-nickname {
      leaf trill-nickname {
        type trill-rb-nickname;
      }
    }
  }
  description
    "presence of this node indicate out of band request needed";
}
leaf diagnostic-vlan {
  type boolean;
  description
    "indicates whether to include diagnostic VLAN/fgl TLV or not
```

```
        in the request.  actual value is the VLAN/FGL specified
        in the command";
    }
}
```

```
    augment
"/goam:domains/goam:domain/goam:MAAs/goam:MA/goam:MEP/goam:mep-
address" {
    case mep-address-trill {
        leaf mep-address-trill {
            when "/goam:domains/goam:domain/goam:technology='trill'";
            type tril-rb-nickname;
        }
    }
}
    augment "/goam:domains/goam:domain/goam:MAAs/goam:MA/goam:context-
id" {
    case context-id-vlan {
        leaf context-id-vlan {
            type vlan;
        }
    }
    case context-id-fgl {
        leaf context-id-fgl {
            type fgl;
        }
    }
}
    augment "/goam:domains/goam:domain/goam:MAAs/goam:MA/goam:flow-
entropy" {
    case flow-entropy-trill {
        leaf flow-entropy-trill {
            type flow-entropy-trill;
        }
    }
}
    augment
"/goam:domains/goam:domain/goam:MAAs/goam:MA/goam:MEP/goam:context-id"
{
    case context-id-vlan {
        leaf context-id-vlan {
            type vlan;
        }
    }
}
```

```
    }
  }
  case context-id-fgl {
    leaf context-id-fgl {
      type fgl;
    }
  }
}
```

```
  augment
"/goam:domains/goam:domain/goam:MAAs/goam:MA/goam:MEP/goam:flow-
entropy" {
  case flow-entropy-trill {
    leaf flow-entropy-trill {
      type flow-entropy-trill;
    }
  }
}
  augment
"/goam:domains/goam:domain/goam:MAAs/goam:MA/goam:MEP/goam:session/goa
m:context-id" {
  case context-id-vlan {
    leaf context-id-vlan {
      type vlan;
    }
  }
  case context-id-fgl {
    leaf context-id-fgl {
      type fgl;
    }
  }
}
  augment
"/goam:domains/goam:domain/goam:MAAs/goam:MA/goam:MEP/goam:session/goa
m:flow-entropy" {
  case flow-entropy-trill {
    leaf flow-entropy-trill {
      type flow-entropy-trill;
    }
  }
}
```



```

augment "/goam:ping/goam:input" {
  uses command-ext-trill;
}
augment "/goam:ping/goam:input/goam:context-id" {
  case context-id-vlan {
    leaf context-id-vlan {
      type vlan;
    }
  }
  case context-id-fgl {
    leaf context-id-fgl {
      type fgl;
    }
  }
}
}

```

```

augment "/goam:ping/goam:input/goam:flow-entropy" {
  case flow-entropy-trill {
    leaf flow-entropy-trill {
      type flow-entropy-trill;
    }
  }
}
augment "/goam:ping/goam:input/goam:source-mep/goam:mep-address" {
  case trill-nickname {
    leaf trill-nickname {
      type tril-rb-nickname;
    }
  }
}
augment "/goam:ping/goam:input/goam:destination-mep/goam:mep-
address" {
  case trill-nickname {
    leaf trill-nickname {
      type tril-rb-nickname;
    }
  }
}
augment "/goam:ping/goam:output" {
  description
    "adds trill specific items on the response";
  leaf upstream-rbridge {
    type tril-rb-nickname;
  }
}

```

```

    }
    leaf-list next-hop-rbridge {
      type tril-rb-nickname;
      description
        "nickname of the next hop RBRdige";
    }
  }
  augment "/goam:trace-route/goam:input" {
    uses command-ext-trill;
  }
  augment "/goam:trace-route/goam:input/goam:context-id" {
    case context-id-vlan {
      leaf context-id-vlan {
        type vlan;
      }
    }
    case context-id-fgl {
      leaf context-id-fgl {
        type fgl;
      }
    }
  }

```

```

    }
  }
  augment "/goam:trace-route/goam:input/goam:flow-entropy" {
    case flow-entropy-trill {
      leaf flow-entropy-trill {
        type flow-entropy-trill;
      }
    }
  }
  augment "/goam:trace-route/goam:input/goam:source-mep/goam:mep-
address" {
    case trill-nickname {
      leaf trill-nickname {
        type tril-rb-nickname;
      }
    }
  }
  augment "/goam:trace-route/goam:input/goam:destination-
mep/goam:mep-address" {
    case trill-nickname {
      leaf trill-nickname {
        type tril-rb-nickname;
      }
    }
  }

```

```

    }
  }
}
augment "/goam:trace-
route/goam:output/goam:response/goam:destination-mep/goam:mep-
address" {
  case trill-nickname {
    leaf trill-nickname {
      type tril-rb-nickname;
    }
  }
}
augment "/goam:trace-route/goam:output/goam:response" {
  description
    "adds trill specific items on the response";
  leaf upstream-rbridge {
    type tril-rb-nickname;
  }
  leaf-list next-hop-rbridge {
    type tril-rb-nickname;
    description
      "nickname of the next hop RBRdige";
  }
}
rpc mtv {

```

```

description
  "Generates Trace-route and return response. Starts with TTL
  of one and increment by one at each hop. Untill destination
  reached or TTL reach max valune";
input {
  uses goam:maintenance-domain {
    description
      "Specifies the MA-domain";
  }
  uses goam:ma-identifier {
    description
      "identfies the Maintenance association";
  }
  uses command-ext-trill {
    description
      "defines extensions needed for trill.
      We are using this structure so mtv command is in line

```

```

        with ping and trace-route";
    }
    choice context-id {
        case context-id-vlan {
            leaf context-id-vlan {
                type vlan;
            }
        }
        case context-id-fgl {
            leaf context-id-fgl {
                type fgl;
            }
        }
    }
    choice flow-entropy {
        case flow-entropy-null {
            leaf flow-entropy-null {
                type empty;
            }
        }
        case flow-entropy-trill {
            leaf flow-entropy-trill {
                type flow-entropy-trill;
            }
        }
    }
    leaf max-hop-count {
        type uint8;
        default "255";
        description

```

```

        "Defines maximum value of hop count";
    }
    leaf type {
        type identityref {
            base goam:command-sub-type;
        }
        description
            "defines different command types";
    }
    leaf-list scope {
        type tril-rb-nickname;
        reference "draft-ietf-trill-oam-fm";
    }

```

```

    description
      "This list contain rbridges that needed to respond
      Empty list indicate all Rbridges needed to respond";
  }
  leaf ecmp-choice {
    type goam:ecmp-choices;
    description
      "0 means use the specified interface
      1 means use round robin";
  }
  list outgoing-interfaces {
    key "interface";
    leaf interface {
      type if:interface-ref;
    }
  }
  container source-mep {
    uses goam:mep-address;
    leaf mep-id {
      type goam:MEP-id;
    }
  }
  container destination-mep {
    uses goam:mep-address;
    leaf mep-id {
      type goam:MEP-id;
    }
  }
}
output {
  list response {
    key "mep-address mep-id";
    leaf hop-count {
      type uint8;
    }
  }
}

```

```

  leaf mep-id {
    type goam:MEP-id;
  }
  leaf mep-address {
    type tril-rb-nickname;
  }
  leaf-list next-hop-rbridge {

```

10. References

10.1. Normative References

- [RFC2119] Bradner, S., "Key words for use in RFCs to Indicate Requirement Levels", [BCP 14](#), [RFC 2119](#), March 1997.
- [RFC2234] Crocker, D. and Overell, P.(Editors), "Augmented BNF for Syntax Specifications: ABNF", [RFC 2234](#), Internet Mail Consortium and Demon Internet Ltd., November 1997.
- [8021Q] IEEE, "Media Access Control (MAC) Bridges and Virtual Bridged Local Area Networks", IEEE Std 802.1Q-2011, August, 2011.

10.2. Informative References

- [Y1731] ITU, "OAM functions and mechanisms for Ethernet based networks", ITU-T G.8013/Y.1731, July, 2011.
- [TRLOAMFRM] Salam, S., et.al., "TRILL OAM Framework", [draft-ietf-trill-oam-framework](#), Work in Progress, November, 2012.
- [RFC6291] Andersson, L., et.al., "Guidelines for the use of the "OAM" Acronym in the IETF" [RFC 6291](#), June 2011.
- [RFC6325] Perlman, R., et.al., "Routing Bridges (RBridges): Base Protocol Specification", [RFC 6325](#), July 2011.
- [GENYANGOAM] Senevirathne, T., et.al., "YANG Data Model for Operations, Administration and Maintenance (OAM)", Work in Progress, March, 2014.

11. Acknowledgments

Giles Heron came up with the idea of developing a YANG model as a way of creating a unified OAM API set (interface), work in this document is largely an inspiration of that. Alexander Clemm provided many valuable tips, comments and remarks that helped to refine the YANG model presented in this document.

This document was prepared using 2-Word-v2.0.template.dot.

Internet-Draft

YANG Data Model for TRILL OAM

June 2014

Authors' Addresses

Tissa Senevirathne
CISCO Systems
375 East Tasman Drive.
San Jose, CA 95134
USA.

Phone: 408-853-2291
Email: tsenevir@cisco.com

Norman Finn
CISCO Systems
510 McCarthy Blvd
Milpitas, CA 95035.

Email: nfinn@cisco.com

Deepak Kumar
CISCO Systems
510 McCarthy Blvd
Milpitas, CA 95035.

Email: dekumar@cisco.com

Samer Salam
CISCO Systems
595 Burrard St. Suite 2123
Vancouver, BC V7X 1J1, Canada

Email: ssalam@cisco.com

Liang Xia
Huawei technologies

Email: frank.xialiang@huawei.com

Senevirathne

Expires December 10, 2014

[Page 23]

Internet-Draft

YANG Data Model for TRILL OAM

June 2014

Weiguo Hao
Huawei Technologies
101 Software Avenue
Nanjing 210012, China

Email: haoweiguo@huawei.com

Senevirathne

Expires December 10, 2014

[Page 24]