

Network Working Group  
Internet Draft  
Category: Standards Track

Fatai Zhang  
Xian Zhang  
Huawei  
O. Gonzalez de Dios  
Telefonica Investigacion y Desarrollo  
C. Margaria. C  
Coriant  
July 11, 2013

Expires: January 10, 2014

GMPLS-based Hierarchy LSP Creation  
in Multi-Region and Multi-Layer Networks

[draft-zhang-ccamp-gmpls-h-lsp-mln-05.txt](#)

### Abstract

This specification describes the hierarchical LSP creation models in the Multi-Region and Multi-Layer Networks (MRN/MLN), and provides the extensions to the existing protocol mechanisms described in [[RFC4206](#)], [[RFC6107](#)] and [[RFC6001](#)] to create a hierarchical LSP in multiple layer networks.

### Status of this Memo

This Internet-Draft is submitted to IETF in full conformance with the provisions of [BCP 78](#) and [BCP 79](#).

Internet-Drafts are working documents of the Internet Engineering Task Force (IETF), its areas, and its working groups. Note that other groups may also distribute working documents as Internet-Drafts.

Internet-Drafts are draft documents valid for a maximum of six months and may be updated, replaced, or obsoleted by other documents at any time. It is inappropriate to use Internet-Drafts as reference material or to cite them other than as "work in progress."

The list of current Internet-Drafts can be accessed at <http://www.ietf.org/ietf/lid-abstracts.txt>.

The list of Internet-Draft Shadow Directories can be accessed at <http://www.ietf.org/shadow.html>.

This Internet-Draft will expire on January 10, 2014.

---

[draft-zhang-ccamp-gmpls-h-lsp-mln-05.txt](#)

July 2013

## Table of Contents

<a href="#">1.</a>	Introduction .....	<a href="#">2</a>
<a href="#">1.1.</a>	Conventions used in this document .....	<a href="#">3</a>
<a href="#">2.</a>	Provisioning of FA-LSP in Server Layer Network .....	<a href="#">3</a>
<a href="#">2.1.</a>	Selection of Switching Layers.....	<a href="#">3</a>
<a href="#">2.2.</a>	Selection of Switching Granularity Levels .....	<a href="#">4</a>
<a href="#">2.3.</a>	Selection of Adaptation Capabilities .....	<a href="#">6</a>
<a href="#">3.</a>	Signaling Requirements for Server Layer Selection .....	<a href="#">7</a>
<a href="#">3.1.</a>	Model 1: Pre-provisioning of FA-LSP .....	<a href="#">8</a>
<a href="#">3.2.</a>	Model 2: Signaling triggered server layer path computation and setup .....	<a href="#">9</a>
<a href="#">3.3.</a>	Model 3: Signaling triggered server layer path, with explicit server path .....	<a href="#">9</a>
<a href="#">4.</a>	Signaling Extensions ERO Sub-Object .....	<a href="#">10</a>
<a href="#">4.1.</a>	SERVER_LAYER_INFO ERO Subobject .....	<a href="#">10</a>
<a href="#">4.2.</a>	Processing of SERVER_LAYER_INFO sub-object .....	<a href="#">12</a>
<a href="#">4.3.</a>	Alternative Encoding Solutions .....	<a href="#">12</a>
<a href="#">5.</a>	Security Considerations.....	<a href="#">13</a>
<a href="#">6.</a>	IANA Considerations .....	<a href="#">13</a>
<a href="#">7.</a>	Acknowledgments .....	<a href="#">13</a>
<a href="#">8.</a>	References .....	<a href="#">13</a>
<a href="#">8.1.</a>	Normative References.....	<a href="#">13</a>
<a href="#">8.2.</a>	Informative Reference.....	<a href="#">14</a>
<a href="#">9.</a>	Authors' Addresses .....	<a href="#">15</a>

[1.](#) Introduction

Networks may comprise multiple layers which have different switching technologies or different switching granularity levels. The GMPLS technology is required to support control of such network.

[RFC5212] defines the concept of MRN/MLN and describes the framework and requirements of GMPLS controlled MRN/MLN. The GMPLS extension for MRN/MLN, including routing and signaling aspects, is described in [RFC6001].

[RFC4206] and [RFC6107] describe how to set up a hierarchical LSP passing through multi-layer networks and how to advertise the



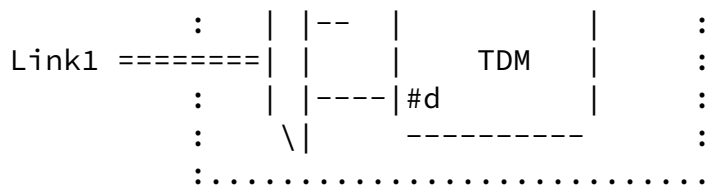

Figure 1 - Hybrid node (Copied from [RFC5339])

In the case where a edge node of a region is a hybrid node, selection of which server layer to create the FA-LSP is necessary.

Figure 2 shows an multi-layer network, where node B and C are region edge nodes having three switching matrices which support, for instance, PSC, TDM and WDM switching, respectively. The three switching matrices are connected to each other by the internal links. Both the link between B and E and the link between E and C support TDM and WDM switching capabilities.

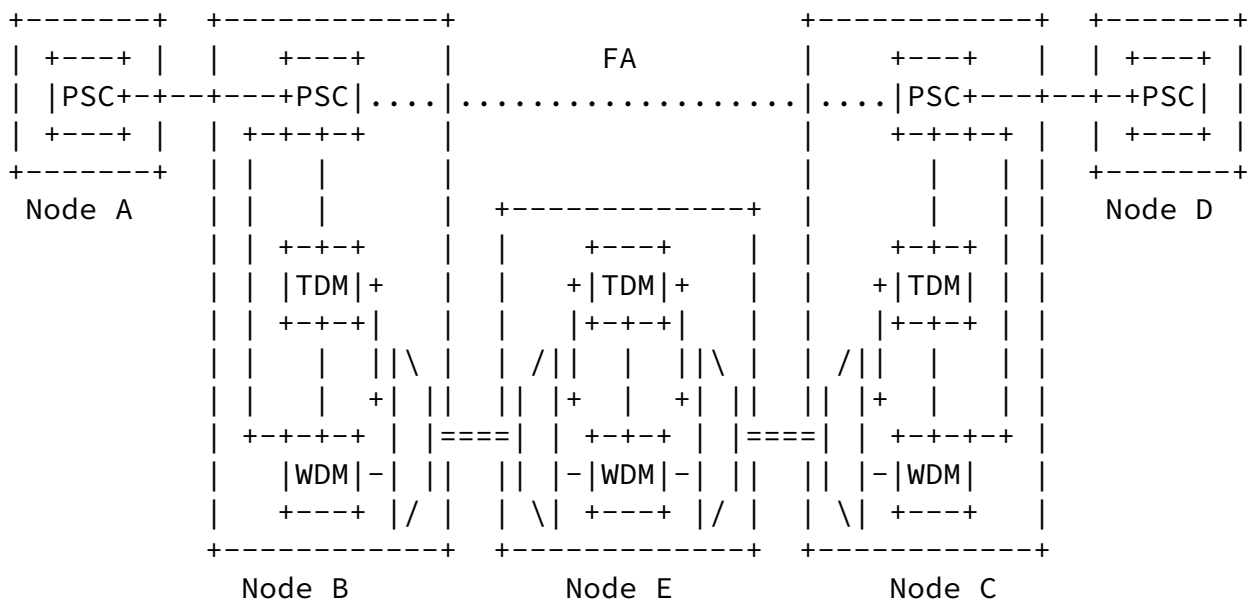

Figure 2 - MLN with multiple ISCs at edge node

As can be seen in Figure 2, there are two choices when providing FA in the PSC layer network between node B and C: one is creating a FA-LSP with TDM switching matrix through node B, E and C, the other is creating a FA-LSP with WDM switching matrix through node B, E and C.

[RFC6001] introduces a new SC (Switching Capability) sub-object into

the XRO (ref. to [RFC4874]). This sub-object is used to indicate which switching capability is not expected to be used. When one of the switching capabilities is selected, the SC sub-object can be included in the message to exclude all other SCs.

## 2.2. Selection of Switching Granularity Levels

Even in the case where the edge node only has one switching capability in the server layer, there may be still multiple choices for the server layer network to set up a FA-LSP to provide new FA in the client layer network. This is because the server layer network may have the capability of providing different switching granularity levels for the FA-LSP.

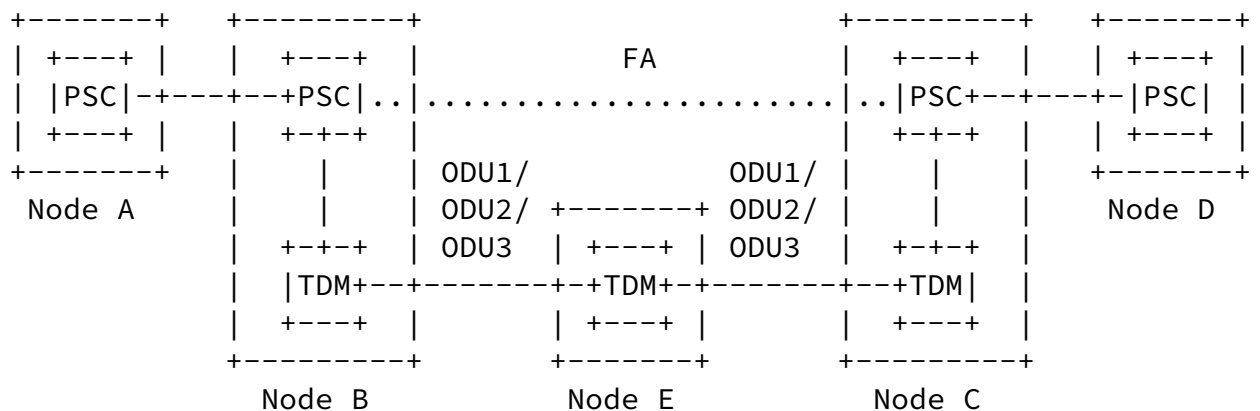
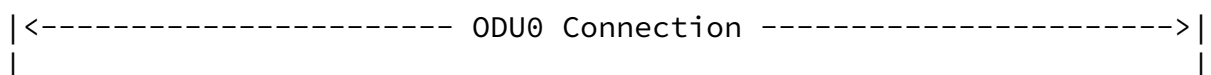

Figure 3a - Multiple switching granularities in server layer

Figure 3a shows an example multi-region network, where the edge node B and C have PSC and TDM switching matrices, and where the TDM switching matrix supports ODU1, ODU2 and ODU3 switching levels. Therefore, when an FA between node B and C in the PSC layer network is needed, either of ODU1, ODU2 or ODU3 connection (FA-LSP) can be created in the TDM layer network.



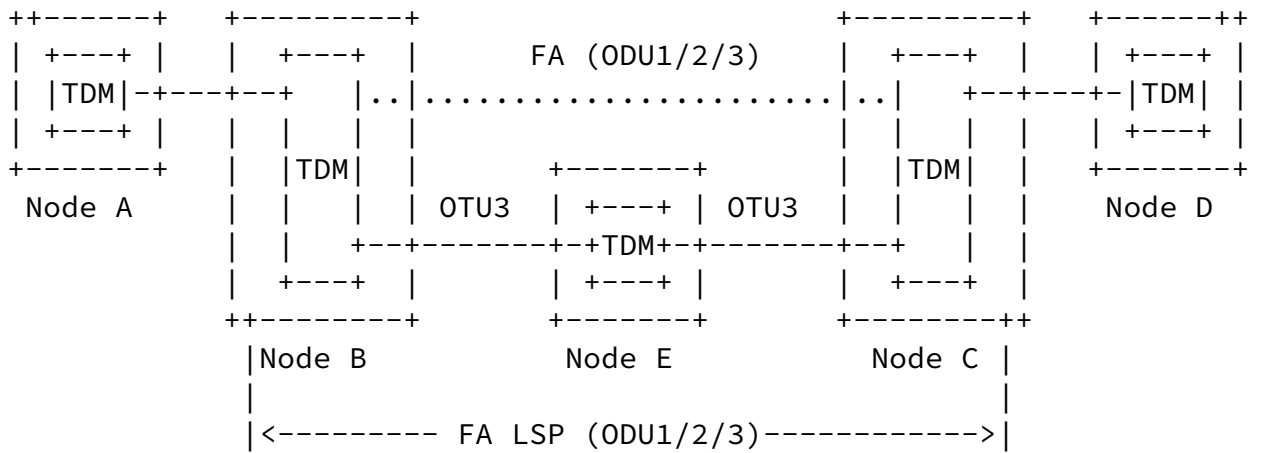

Figure 3b - TDM nested LSP provisioning

Figure 3b is another example multi-layer network within the same region. When there is a need to set up an FA between node B and C for the client layer ODU0 connection, the server layer has multiple

choices, e.g., ODU1 or ODU2 or ODU3, for the FA-LSP if the multi-stage multiplexing is supported at node B and C.

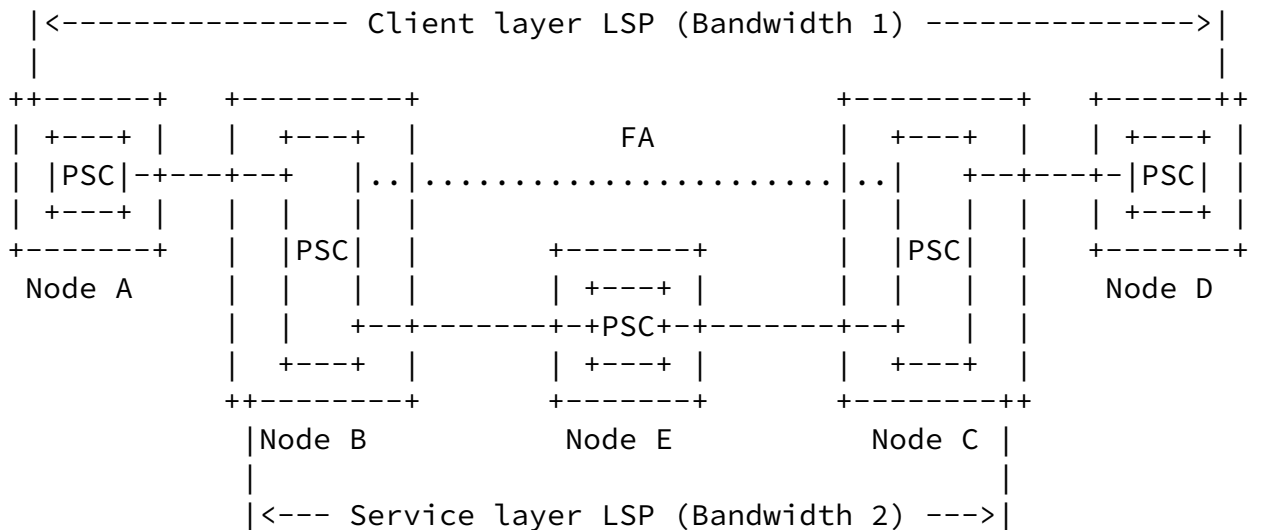

Figure 3c - PSC nested LSP provisioning

Figure 3c is a third example showing an LSP nesting scenario in a PSC signal-layer network (e.g., an MPLS-TP network). A PSC tunnel passing

through node B, E and C is requested to carry the client layer LSP. There are multiple choices of the bandwidth of the tunnel, on the premise that the bandwidth of the FA-LSP is equal to or larger than the client layer LSP.

The selection of server layer switching matrix and switching granularity is based on both policy and bandwidth resources. The selection can be performed by a planning tool and/or NMS/PCE/VNTM (Virtual Network Topology Manager, see [RFC5623]) and/or the network node.

### 2.3. Selection of Adaptation Capabilities

Adaptation function also needs to be selected when creating the server layer connection. This is because the edge nodes may support multiple adaptation functions.

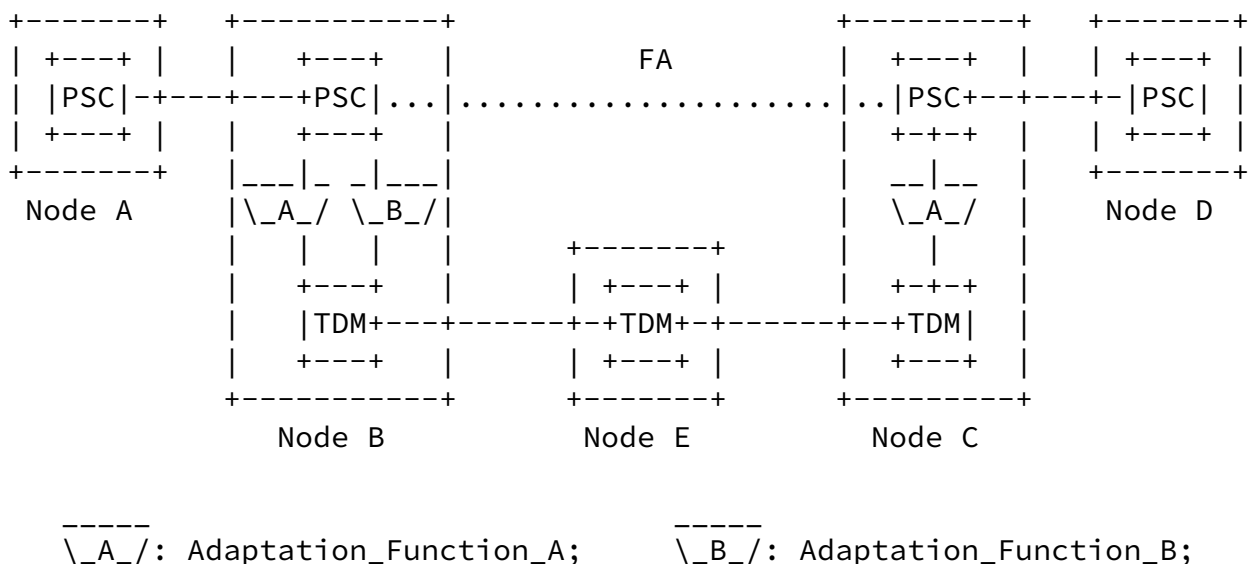

Figure 4 - Selection of adaptation function

For example, in Figure 4, edge node B supports two adaptation functions, i.e., adaptation\_function\_A and adaptation\_function\_B, while edge node C only supports adaptation\_function\_A. In this case, only adaptation\_function\_A can be used for the server layer connection.

The Call procedure ([RFC4974]) may be used between edge node B and C to negotiate and determine the adaptation function for the server layer if the Call function is supported.

### 3. Signaling Requirements for Server Layer Selection

[RFC5623], the framework of PCE-based MLN, provides the models of cross-layer LSP path computation and creation, which are listed below:

- Inter-Layer Path Computation Models:
  - o Single PCE
  - o Multiple PCE with inter-PCE
  - o Multiple PCE without inter-PCE
- Inter-Layer Path Control Models:
  - o PCE-VNTM cooperation

- o Higher-layer signaling trigger
- o NMS-VNTM cooperation (integrated flavor)
- o NMS-VNTM cooperation (separate flavor)

This section keeps alignment with [RFC5623] except that the restriction of using a PCE for path computation is not necessary (i.e., other element, such as a network node, may also have path computation capability).

In this document, those models in [RFC4206] are mapped into 3 models on the viewpoint of signaling:



- Model 1: Pre-provisioning of FA-LSP
- Model 2: Signaling triggered server layer path computation and setup
- Model 3: Signaling triggered server layer path, with explicit server path.

### 3.1. Model 1: Pre-provisioning of FA-LSP

In this model, the FA-LSP in the server layer is created before initiating the signaling of the client layer LSP. Two typical scenarios using this model are:

- Network planning and building at the stage of client network initialization.
- NMS/VNTM triggering the creation of FA-LSP when computing the path of client layer LSP. The path control models of PCE-VNTM cooperation and NMS-VNTM cooperation (both integrated and separate flavor) in [[RFC5623](#)] belong to this scenario.

In such case, the server layer selection and path computation is performed by planning tool or NMS/PCE/VNTM or the edge node. The signaling of client layer LSP and server layer FA-LSP are separated. The normal LSP creation procedures ([[RFC3471](#)] and [[RFC3473](#)]) are followed to set up these two LSPs and no new extension is required.

### 3.2. Model 2: Signaling triggered server layer path computation and setup

In this model, the source node of client layer LSP only computes the route within its own layer network. When the signaling of the client layer LSP reaches at the region edge node, the edge node performs server layer FA-LSP path computation and then creates the FA-LSP. When a PCE is introduced to perform path computation in each layer of the multi-layer network, this model is the same as the model of

"higher-layer signaling trigger with Multiple PCE without inter-PCE" in [[RFC5623](#)].

In such case, the edge node will receive the client layer PATH message with a loose ERO indicating an FA is requested, and may perform the server layer selection (e.g., through the server layer PCE or the VNTM) and then compute and set up the FA-LSP. The signaling procedure of client layer LSP and server layer FA-LSP is described in detail in [[RFC4206](#)] and [[RFC6107](#)].

It's possible that the source node of the client layer LSP selects the server layer SC and/or granularity and/or adaptation function when performing path computation in the client layer, and requests or suggests the edge node to use an appointed server layer to create the FA-LSP.

In this case, the XRO including SC sub-object ([[RFC6001](#)]) is adopted for the server layer SC exclusion, which can be used indirectly to select server layer SC. Such solution is not straightforward enough. Furthermore it cannot be used for the selection of server layer granularity and adaptation function. Therefore, new extensions for the selection of server layer SC, switching granularity and adaptation function are required.

### [3.3](#). Model 3: Signaling triggered server layer path, with explicit server path

In this model, the source node of the client layer LSP performs a full path computation including the client layer and the server layer routes. The server layer FA-LSP creation is triggered at the edge node by the client layer LSP signaling. When a PCE is introduced to perform path computation in the multi-layer network, this model is the same as the model of "Higher-layer signaling trigger with Single PCE" or "Higher-layer signaling trigger with Multiple PCE with inter-PCE" in [[RFC5623](#)].

In such case, the server layer selection and server layer path computation is performed at the source node of the client layer LSP (e.g., through VNTM or PCE), but not at the edge node.

In [[RFC4206](#)], the ERO which contains the list of nodes and links (including the client layer and server layer) along the path is used in the client layer PATH message. The edge node can find out the tail end of the FA-LSP based on the switching capability of the node using the IGP database (see session 6.2 of [[RFC 4206](#)]).

Similar to the problem of model 2, the edge node is not aware of which switching granularity and which adaptation function to be selected for the FA-LSP because the ERO and/or XRO do not contain such information. Therefore, the edge node may not be able to create the FA-LSP, or may select another switching granularity by itself which is different from the one selected previously at the source node, which makes the creation of hierarchy LSP out of control.

Therefore, new extensions for the selection of server layer SC, switching granularity and adaptation function are also required in this model.

#### [4.](#) Signaling Extensions ERO Sub-Object

##### [4.1.](#) SERVER\_LAYER\_INFO ERO Subobject

In order to solve the problems described in the previous sections, a new sub-object named SERVER\_LAYER\_INFO sub-object is introduced in this document, which is carried in the ERO and is used to explicitly indicate which server layer to create the FA-LSP.

The SERVER\_LAYER\_INFO sub-object is put immediately after the node or link (interface) address sub-object, indicating the related node is a region edge node on the LSP in the ERO.

The format of the SERVER\_LAYER\_INFO sub-object is shown below:

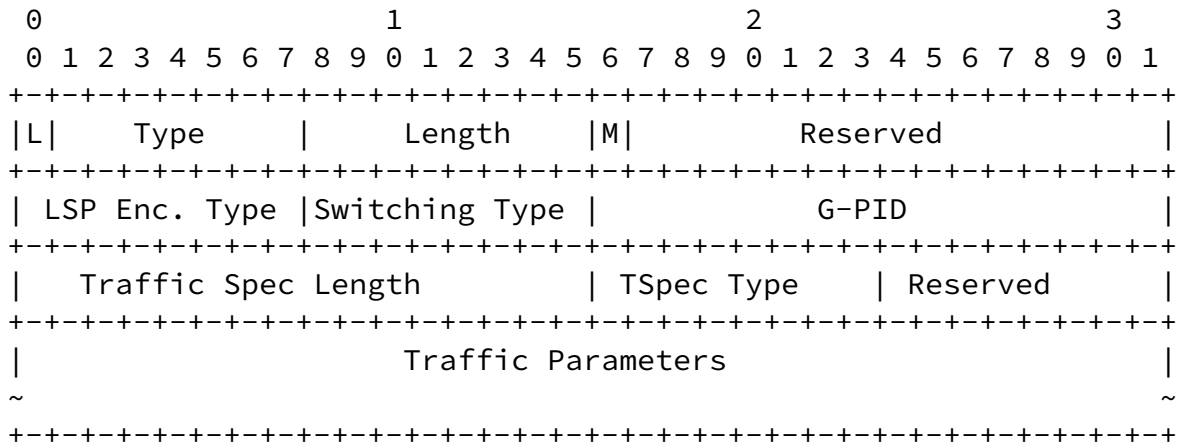

[Editor's note: the encoding is still under discussion.]

- L bit: MUST be zero and MUST be ignored when received.
- Type: The SERVER\_LAYER\_INFO sub-object has a type of xx (TBD).
- Length: The total length of the sub-object in bytes, including the Type and Length fields. The value of this field is always a multiple of 4.
- M (Mandatory) bit: When set, it means the edge node MUST set up the FA-LSP in the appointed server layer; otherwise, the appointed server layer is suggested and the edge node may select other server layer by local policy.
- LSP Encoding Type, Switching Type and G-PID: These 3 fields are used to point out which switching layer is requested to set up the FA-LSP. The values of these 3 fields are inherited from the Generalized Label Request Object in GMPLS signaling, referring to [\[RFC3471\]](#), [\[RFC3473\]](#) and other related standards and drafts. Note that G-PID can be used to indicate the payload type of the server layer (i.e., the client signal) as well as the adaptation function for adapting the client signal into the server layer FA-LSP.
- Traffic Spec Length, TSpec Type, Traffic Parameters: The traffic parameters field is used to indicate the switching granularity of the FA-LSP. The format of this field depends on the TSpec Type Traffic Spec Length and is consistent with the existing standards and drafts. For example, the traffic parameters of Ethernet, SONET/SDH and OTN are defined in [\[RFC6003\]](#), [\[RFC4606\]](#) and [OTN-ctrl] respectively.

#### 4.2. Processing of SERVER\_LAYER\_INFO sub-object

As described in [RFC3209](#) and [RFC3473](#) the ERO is managed as a sub-object list. The SERVER\_LAYER\_INFO sub-object MUST be appended after the existing sub-object defined in [[RFC3209](#)], [[RFC3473](#)], [[RFC3477](#)], [[RFC4873](#)], [[RFC4874](#)], [[RFC5520](#)] and [[RFC5553](#)] TBD:extensions.

When a node receives a PATH message containing ERO and finds that there is a SERVER\_LAYER\_INFO sub-object immediately after the node or link address sub-object related to itself, the node determines that it's a region edge node. Then, the edge node finds out the server layer selection information from the sub-object:

- Determine the switching layer by the LSP Encoding Type and Switching Type fields;
- Determine the switching granularity of the FA-LSP by the Traffic Parameters field;
- Determine the adaptation function for adapting the client signal into the server layer FA-LSP by the G-PID field.

The edge node MUST then determine the other edge of the region, i.e., the tail end of the FA-LSP, with respect to the subsequence of hops of the ERO. The node that satisfies the following conditions will be treated as the tail end of the FA-LSP:

- There is a SERVER\_LAYER\_INFO sub-object that immediately follows the node or link address sub-object which is related to that node;
- The LSP Encoding Type, Switching Type, G-PID and the Traffic Parameters fields of this SERVER\_LAYER\_INFO sub-object is the same as the SERVER\_LAYER\_INFO sub-object corresponding to the head end;
- The node is the first one that satisfies the two conditions above in the subsequence of hops of the ERO.

If a match of tail end is found, the head end now has the clear server layer information of the FA-LSP and then initiates an RSVP-TE session to create the FA-LSP in the appointed server layer between the head end and the tail end.

#### 4.3. Alternative Encoding Solutions

[Editor's note: the section is still under discussion.]

---

[draft-zhang-ccamp-gmpls-h-lsp-mln-05.txt](#)

July 2013

A first alternative solution is to use the mechanism defined in [LSP-RO], i.e., create an ERO HOP attribute TLV.

The content and procedure are not changed from the previous section.

5. A second alternative solution aims to simplify the SERVER\_LAYER\_INFO processing by using the SERO mechanisms. This can be a new requirements to the SERO or to the ERO Hop attribute. This alternative is not further described here but mentioned for discussions.

6. Security Considerations

TBD.

7. IANA Considerations

TBD.

8. Acknowledgments

TBD.

9. References

9.1. Normative References

- [RFC2119] Bradner, S., "Key words for use in RFCs to Indicate Requirement Levels", [BCP 14](#), [RFC 2119](#), March 1997.
- [RFC3945] Mannie, E., "Generalized Multi-Protocol Label Switching (GMPLS) Architecture", [RFC 3945](#), October 2004.
- [RFC3209] D. Awduche et al, "RSVP-TE: Extensions to RSVP for LSP Tunnels", [RFC3209](#), December 2001.
- [RFC3471] Berger, L., Ed., "Generalized Multi-Protocol Label Switching (GMPLS) Signaling Functional Description", [RFC 3471](#), January 2003.

- [RFC3473] L. Berger, Ed., "Generalized Multi-Protocol Label Switching (GMPLS) Signaling Resource Reservation Protocol-Traffic Engineering (RSVP-TE) Extensions", [RFC 3473](#), January 2003.

- [RFC5212] K. Shiomoto et al, "Requirements for GMPLS-Based Multi-Region and Multi-Layer Networks (MRN/MLN)", [RFC5212](#), July 2008.
- [RFC5339] JL. Le Roux et al, "Evaluation of Existing GMPLS Protocols against Multi-Layer and Multi-Region Networks (MLN/MRN)", [RFC5339](#), September 2008.
- [RFC4206] K. Kompella et al, "Label Switched Paths (LSP) Hierarchy with Generalized Multi-Protocol Label Switching (GMPLS) Traffic Engineering (TE)", [RFC4206](#), October 2005.
- [RFC6107] K. Shiomoto, A. Farrel, "Procedures for Dynamically Signaled Hierarchical Label Switched Paths", [RFC6107](#), February 2011.
- [RFC6001] Dimitri Papadimitriou et al, "Generalized Multi-Protocol Label Switching (GMPLS) Protocol Extensions for Multi-Layer and Multi-Region Networks (MLN/MRN)", [RFC6001](#), October, 2010.

## [9.2](#). Informative Reference

- [RFC4974] D. Papadimitriou and A. Farrel, "Generalized MPLS (GMPLS) RSVP-TE Signaling Extensions in Support of Calls", [RFC4974](#), August 2007.
- [RFC5623] E. Oki et al, "Framework for PCE-Based Inter-Layer MPLS and GMPLS Traffic Engineering", [RFC 5623](#), September 2009.
- [RFC4606] E. Mannie, D. Papadimitriou, "Generalized Multi-Protocol Label Switching (GMPLS) Extensions for Synchronous Optical Network (SONET) and Synchronous Digital Hierarchy (SDH) Control", [RFC 4606](#), August 2006.
- [OTN-ctrl] Fatai Zhang et al, "Generalized Multi-Protocol Label

witching (GMPLS) Signaling Extensions for the evolving G.709 Optical Transport Networks Control", [draft-ietf-ccamp-gmpls-signaling-g709v3-08.txt](#), April, 2013.

[RFC6003] D. Papadimitriou, "Ethernet Traffic Parameters", [RFC6003](#), October, 2010.

[LSP-RO] Margaria, C., Giovanni, G., et al, "[draft-ietf-ccamp-lsp-attribute-ro](#)", [draft-ietf-ccamp-lsp-attribute-ro-01.txt](#), work I progress;

Zhang

Expires January 2014

[Page 14]

---

[draft-zhang-ccamp-gmpls-h-lsp-mln-05.txt](#)

July 2013

## 10. Authors' Addresses

Fatai Zhang  
Huawei Technologies  
F3-1B R&D Center, Huawei Base  
Bantian, Longgang District  
Shenzhen 518129 P.R.China

Phone: +86-755-28972603  
Email: zhangfatai@huawei.com

Xian Zhang  
Huawei Technologies  
F3-1B R&D Center, Huawei Base  
Bantian, Longgang District  
Shenzhen 518129 P.R.China

Phone: +86-755-28972645  
Email: huawei.danli@huawei.com

Yi Lin  
Huawei Technologies Co., Ltd.  
F3-1B R&D Center, Huawei Base  
Bantian, Longgang District  
Shenzhen 518129 P.R.China

Phone: +86-755-28972597  
Email: yi.lin@huawei.com



Oscar Gonzalez de Dios  
Telefonica Investigacion y Desarrollo  
Emilio Vargas 6  
Madrid, 28045 Spain

Phone: +34 913374013  
Email: ogondio@tid.es

Zhang

Expires January 2014

[Page 15]

---

[draft-zhang-ccamp-gmpls-h-lsp-mln-05.txt](#)

July 2013

Cyril Margaria  
Coriant GmbH  
St Martin Strasse 76  
Munich, 81541  
Germany

Phone: +49 89 5159 16934  
Email: cyril.margaria@coriant.com

## Intellectual Property

The IETF Trust takes no position regarding the validity or scope of any Intellectual Property Rights or other rights that might be claimed to pertain to the implementation or use of the technology described in any IETF Document or the extent to which any license under such rights might or might not be available; nor does it represent that it has made any independent effort to identify any such rights.

Copies of Intellectual Property disclosures made to the IETF Secretariat and any assurances of licenses to be made available, or the result of an attempt made to obtain a general license or permission for the use of such proprietary rights by implementers or users of this specification can be obtained from the IETF on-line IPR

repository at <http://www.ietf.org/ipr>

The IETF invites any interested party to bring to its attention any copyrights, patents or patent applications, or other proprietary rights that may cover technology that may be required to implement any standard or specification contained in an IETF Document. Please address the information to the IETF at [ietf-ipr@ietf.org](mailto:ietf-ipr@ietf.org).

The definitive version of an IETF Document is that published by, or under the auspices of, the IETF. Versions of IETF Documents that are published by third parties, including those that are translated into other languages, should not be considered to be definitive versions of IETF Documents. The definitive version of these Legal Provisions is that published by, or under the auspices of, the IETF. Versions of these Legal Provisions that are published by third parties, including those that are translated into other languages, should not be considered to be definitive versions of these Legal Provisions.

For the avoidance of doubt, each Contributor to the IETF Standards Process licenses each Contribution that he or she makes as part of

Zhang

Expires January 2014

[Page 16]

---

[draft-zhang-ccamp-gmpls-h-lsp-mln-05.txt](#)

July 2013

the IETF Standards Process to the IETF Trust pursuant to the provisions of [RFC 5378](#). No language to the contrary, or terms, conditions or rights that differ from or are inconsistent with the rights and licenses granted under [RFC 5378](#), shall have any effect and shall be null and void, whether published or posted by such Contributor, or included with or in such Contribution.

#### Disclaimer of Validity

All IETF Documents and the information contained therein are provided on an "AS IS" basis and THE CONTRIBUTOR, THE ORGANIZATION HE/SHE REPRESENTS OR IS SPONSORED BY (IF ANY), THE INTERNET SOCIETY, THE IETF TRUST AND THE INTERNET ENGINEERING TASK FORCE DISCLAIM ALL WARRANTIES, EXPRESS OR IMPLIED, INCLUDING BUT NOT LIMITED TO ANY WARRANTY THAT THE USE OF THE INFORMATION THEREIN WILL NOT INFRINGE ANY RIGHTS OR ANY IMPLIED WARRANTIES OF MERCHANTABILITY OR FITNESS FOR A PARTICULAR PURPOSE.

## Copyright Notice

Copyright (c) 2013 IETF Trust and the persons identified as the document authors. All rights reserved.

This document is subject to [BCP 78](#) and the IETF Trust's Legal Provisions Relating to IETF Documents (<http://trustee.ietf.org/license-info>) in effect on the date of publication of this document. Please review these documents carefully, as they describe your rights and restrictions with respect to this document. Code Components extracted from this document must include Simplified BSD License text as described in Section 4.e of the Trust Legal Provisions and are provided without warranty as described in the Simplified BSD License.