

Network Working Group  
INTERNET-DRAFT  
Expires: August 2003

L-E. Jonsson  
Ericsson  
February 13, 2003

RObust Header Compression (ROHC):  
Terminology and Channel Mapping Examples  
<[draft-ietf-rohc-terminology-and-examples-02.txt](mailto:draft-ietf-rohc-terminology-and-examples-02.txt)>

### Status of this memo

This document is an Internet-Draft and is in full conformance with all provisions of [Section 10 of RFC2026](#).

Internet-Drafts are working documents of the Internet Engineering Task Force (IETF), its areas, and its working groups. Note that other groups may also distribute working documents as Internet-Drafts.

Internet-Drafts are draft documents valid for a maximum of six months and may be updated, replaced, or obsoleted by other documents at any time. It is inappropriate to use Internet-Drafts as reference material or cite them other than as "work in progress".

The list of current Internet-Drafts can be accessed at <http://www.ietf.org/ietf/lid-abstracts.txt>

The list of Internet-Draft Shadow Directories can be accessed at <http://www.ietf.org/shadow.html>

This document is a submission of the IETF ROHC WG. Comments should be directed to the ROHC WG mailing list, [rohc@ietf.org](mailto:rohc@ietf.org).

### Abstract

[RFC 3095](#) defines a Proposed Standard framework with profiles for RObust Header Compression (ROHC). The standard introduces various concepts which might be difficult to understand and especially to relate correctly to the surrounding environments where header compression may be used. This document aims at clarifying these aspects of ROHC, discussing terms such as ROHC instances, ROHC channels, ROHC feedback, and ROHC contexts, and how these terms relate to other terms like network elements and IP interfaces, commonly used for example when addressing MIB issues.

---

INTERNET-DRAFT ROHC Terminology and Channel Mappings February 13, 2003

## Table of Contents

<a href="#">1.</a>	Introduction.....	<a href="#">2</a>
<a href="#">2.</a>	Terminology.....	<a href="#">3</a>
<a href="#">3.</a>	ROHC External Terminology.....	<a href="#">6</a>
<a href="#">3.1.</a>	Network Elements and IP Interfaces.....	<a href="#">6</a>
<a href="#">3.2.</a>	Channels.....	<a href="#">6</a>
<a href="#">3.3.</a>	A Unidirectional Point-to-Point Link Example.....	<a href="#">8</a>
<a href="#">3.4.</a>	A Bi-directional Point-to-Point Link Example.....	<a href="#">8</a>
<a href="#">3.5.</a>	A Bi-directional Multipoint Link Example.....	<a href="#">9</a>
<a href="#">3.6.</a>	A Multi-Channel Point-to-Point Link Example.....	<a href="#">9</a>
<a href="#">4.</a>	ROHC Instances.....	<a href="#">10</a>
<a href="#">4.1.</a>	ROHC Compressors.....	<a href="#">11</a>
<a href="#">4.2.</a>	ROHC Decompressors.....	<a href="#">12</a>
<a href="#">5.</a>	ROHC Channels.....	<a href="#">12</a>
<a href="#">6.</a>	ROHC Feedback Channels.....	<a href="#">13</a>
<a href="#">6.1.</a>	Single-Channel Dedicated ROHC FB Channel Example.....	<a href="#">14</a>
<a href="#">6.2.</a>	Piggybacked/Interspersed ROHC FB Channel Example.....	<a href="#">15</a>
<a href="#">6.3.</a>	Dual-Channel Dedicated ROHC FB Channel Example.....	<a href="#">16</a>
<a href="#">7.</a>	ROHC Contexts.....	<a href="#">17</a>
<a href="#">8.</a>	Summary.....	<a href="#">17</a>
<a href="#">9.</a>	Implementation Implications.....	<a href="#">18</a>
<a href="#">10.</a>	Security Considerations.....	<a href="#">19</a>
<a href="#">11.</a>	Acknowledgements.....	<a href="#">19</a>
<a href="#">12.</a>	References.....	<a href="#">19</a>
<a href="#">13.</a>	Author's Address.....	<a href="#">19</a>

## [1.](#) Introduction

In [RFC 3095](#), the RObust Header Compression (ROHC) standard framework is defined along with 4 compression profiles [[RFC-3095](#)]. Various concepts are introduced within the standard, which might not all be very extensively defined and described, and that can easily be an obstacle when trying to understand the standard. This can be the case especially when one considers how the various parts of ROHC relate to the surrounding environments where header compression may be used.

The purpose of this document is to clarify these aspects of ROHC through examples and additional terminology, discussing terms such as

ROHC instances, ROHC channels, ROHC feedback, and ROHC contexts. This especially means to clarify how these terms relate to other terms, such as network elements and IP interfaces, which are commonly used for example when addressing MIB issues. One explicit goal with this document is to support and simplify the ROHC MIB development work.

The main part of this document, sections [3](#) to [8](#), focuses on clarifying the conceptual aspects, entity relationships, and terminology of ROHC [[RFC-3095](#)]. After that, [section 9](#) explains some implementation implications that arise from these conceptual aspects.

## [2.](#) Terminology

### ROHC instance

A logical entity that performs header compression or decompression according to one or several ROHC profiles can be referred to as a ROHC instance. A ROHC instance is either a ROHC compressor instance or a ROHC decompressor instance. See [section 4](#).

### ROHC compressor instance

A ROHC compressor instance is a logical entity that performs header compression according to one or several ROHC profiles. There is a one-to-one relation between a ROHC compressor instance and a ROHC channel, where the ROHC compressor is located at the input end of the ROHC channel. See [section 4.1](#).

### ROHC decompressor instance

A ROHC decompressor instance is a logical entity that performs header decompression according to one or several ROHC profiles. There is a one-to-one relation between a ROHC decompressor instance and a ROHC channel, where the ROHC decompressor is located at the output end of the ROHC channel. See [section 4.2](#).

### Corresponding decompressor

When talking about a compressor's corresponding decompressor, this refers to the peer decompressor located at the other end of the ROHC channel to which the compressor sends compressed header

packets, i.e. the decompressor that decompresses the headers compressed by the compressor.

#### Corresponding compressor

When talking about a decompressor's corresponding compressor, this refers to the peer compressor located at the other end of the ROHC channel from which the decompressor receives compressed header packets, i.e. the compressor that compresses the headers the decompressor decompresses.

#### ROHC peers

A ROHC compressor and its corresponding ROHC decompressor are referred to as ROHC peers.

#### Link

A communication path between two network entities is in this document generally referred to as a link.

#### Bi-directional compression

If there are means to send feedback information from a decompressor to its corresponding compressor, the compression performance can be improved. This way of operating, utilizing the feedback possibility for improved compression performance, is referred to as bi-directional compression.

#### Unidirectional compression

If there are no means to send feedback information from a decompressor to its corresponding compressor, the compression performance might not be as good as if feedback can be utilized. This way of operating, without making use of feedback for improved compression performance, is referred to as unidirectional compression.

#### ROHC channel

When a ROHC compressor has transformed original packets into ROHC

packets with compressed headers, these ROHC packets are sent to the corresponding decompressor through a logical point-to-point connection dedicated to that traffic. Such a logical channel, which only has to carry data in this single direction from compressor to decompressor, is referred to as a ROHC channel. See further [section 5](#).

#### ROHC feedback channel

To allow bi-directional compression operation, a logical point-to-point connection must be provided for feedback data from the decompressor to its corresponding compressor. Such a logical channel, which only has to carry data in the single direction from decompressor to compressor, is referred to as a ROHC feedback channel. See further [section 6](#).

#### Co-located compressor/decompressor

A minimal ROHC instance is only a compressor or a decompressor, communicating with a corresponding decompressor or compressor peer at the other end of a ROHC channel, thus handling packet streams sent in one direction over the link. However, in many cases the link will carry packet streams in both directions, and it would then be desirable to also perform header compression in both directions. That would require both a ROHC compressor and a ROHC decompressor at each end of the link, each referred to as a co-located compressor/decompressor pair.

#### Associated compressor/decompressor

If there is a co-located ROHC compressor/decompressor pair at each end of a link, feedback messages can be transmitted from a ROHC decompressor to its corresponding compressor by creating a virtual ROHC feedback channel among the compressed header packets sent from the co-located ROHC compressor to the decompressor co-located with the compressor at the other end. When a co-located ROHC compressor/decompressor pair is connected for this purpose, they are said to be associated with each other.

## Interspersed feedback

Feedback from a ROHC decompressor to a ROHC compressor can either be sent on a separate ROHC feedback channel dedicated to feedback packets, or sent among compressed header packets going in the opposite direction from a co-located (associated) compressor to a similarly co-located decompressor at the other end of the link. If feedback packets are transmitted in the latter way and sent as stand-alone packets, this is referred to as interspersed feedback. See further [section 6.2](#) for an example.

## Piggybacked feedback

Feedback from a ROHC decompressor to a ROHC compressor can either be sent on a separate ROHC feedback channel dedicated to feedback packets, or sent among compressed header packets going in the opposite direction from a co-located (associated) compressor to a similarly co-located decompressor at the other end of the link. If feedback packets are transmitted in the latter way and sent encapsulated within compressed header packets going in the other direction, this is referred to as piggybacked feedback. See further [section 6.2](#) for an example.

## Dedicated feedback channel

A dedicated feedback channel is a logical layer two channel from a ROHC decompressor to a ROHC compressor, used only to transmit feedback packets. See further [section 6.1](#) and 6.3 for examples.

When considering aspects of ROHC that relate to the surrounding networking environment where header compression may be applied, unnecessary confusion is easily created because a common, well understood and well defined, terminology is missing. One major goal with this document is to define the preferred terminology to use when discussing header compression network integration issues.

### 3.1. Network Elements and IP Interfaces

Header compression is applied over certain links, between two communicating entities in a network. Such entities may be referred to as "nodes", "network devices", or "network elements", all terms usually having the same meaning. However, practice within the area of network management favors using the term "network element", which is therefore consistently used throughout the rest of this document.

A network element communicates through one or several network interfaces, which are often subject to network management, as defined by MIB specifications. In all IP internetworking, each such interface has its own IP identity, providing a common network interface abstraction, independent of the link technology hidden below the interface. Throughout the rest of this document, such interfaces will be referred to as "IP interfaces".

To visualize the above terms, the top level hierarchy of a network element is thus the following, with one or several IP interfaces:

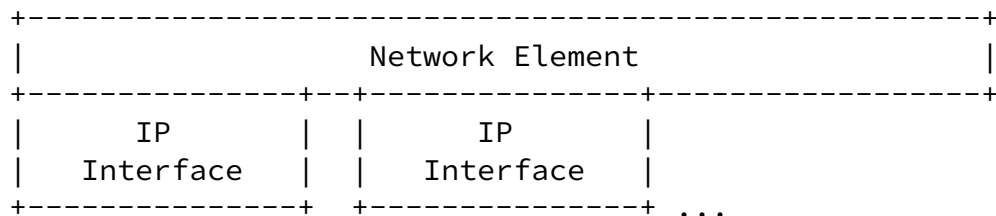

The next section further builds on this top level hierarchy by looking at what is below an IP interface.

### 3.2. Channels

As mentioned in the previous section, an IP interface can be implemented on top of almost any link technology, although different link technologies have different characteristics, and provide communication by different means. However, all link technologies provide the common capability to send and/or receive data to/from the IP interface. A generic way of visualizing the common ability to communicate is to envision it as one or several logical communication channels provided by the link, where each channel can be either bi-

INTERNET-DRAFT ROHC Terminology and Channel Mappings February 13, 2003

directional or unidirectional. Such logical point-to-point connections will throughout the rest of this document be referred to as "channels", either bi-directional or unidirectional. Note that this definition of "channels" is less restrictive than the definition of "ROHC channels", as given in [section 5](#).

Extending the above network element hierarchy with the concept of channels would then lead to the following:

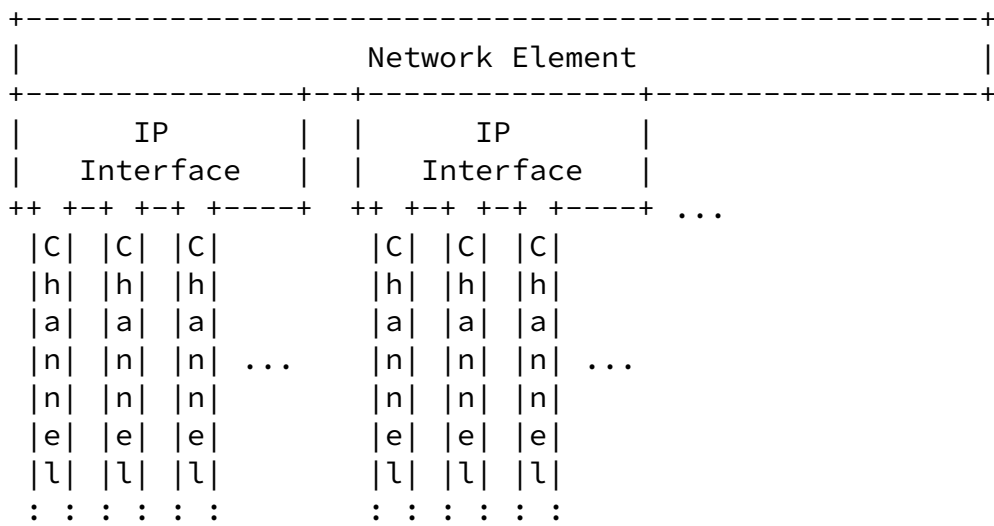

Whether there is more than one channel, and whether the channel(s) is/are bi-directional or unidirectional (or a mix of both) is link technology dependent, as is the way in which channels are logically created.

The following subsections, 3.3-3.6, give a number of different link examples, and relate these to the general descriptions above. Further, each section discusses how header compression might be applied in that particular case. The core questions for header compression are:

- Are channels bi- or unidirectional?
- Is the link point-to-point? If not, a lower layer addressing scheme is needed to create logical point-to-point channels.

Note that these subsections talk about header compression in general, while later sections will address the case of ROHC in more detail. Further, one should remember that in the later sections, the general channel definition is slightly enhanced for header compression by the



definition of the ROHC channel ([section 5](#)) and the ROHC feedback channel ([section 6](#)), while here the basic channel concept is used, as defined above.

### 3.3. A Unidirectional Point-to-Point Link Example

The simplest possible link example one can derive from the general overview above is the case with one single unidirectional channel between two communicating network elements.

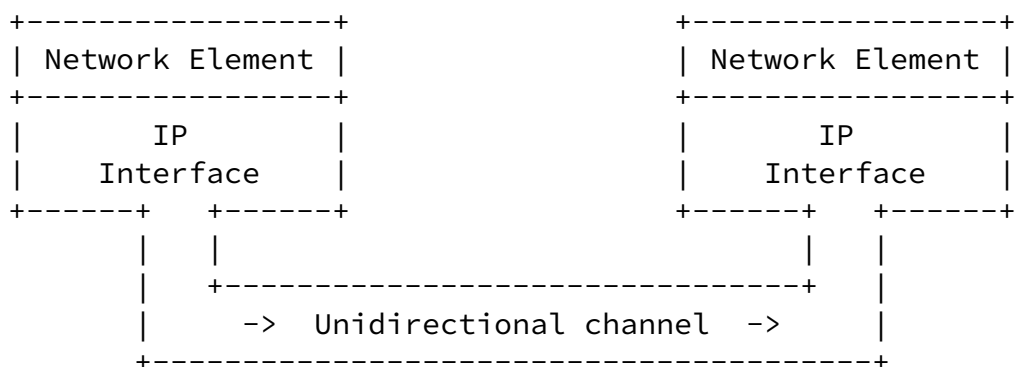

A typical example of a point-to-point link with one unidirectional channel like this is a satellite link. Since there is no return path present, only unidirectional header compression can be applied here.

### 3.4. A Bi-directional Point-to-Point Link Example

Taking the above example one step further, the natural extension would be an example with one single bi-directional channel between two communicating network elements. In this example, there are still only two endpoints and one single channel, but the channel is simply enhanced to allow bi-directional communication.





scheme, to provide logical point-to-point channels, according to the definition of "channels".

As an aside, it should be noted that a case of unidirectional multipoint links is basically the same as a number of unidirectional point-to-point links. In such a case, each receiver only sees one single sender, and the sender's behavior is independent of the number of receivers and unaffected by their behavior.

### 3.6. A Multi-Channel Point-to-Point Link Example

This final example addresses a scenario which is expected to be typical in many environments where ROHC will be applied. The key point of the example is the multi-channel property, which is common in for example cellular environments. Data through the same IP interface might here be transmitted on different channels, depending on its characteristics. In the following example, there are three channels present, one bi-directional, and one unidirectional in each direction, but the channel configuration could of course be arbitrary.

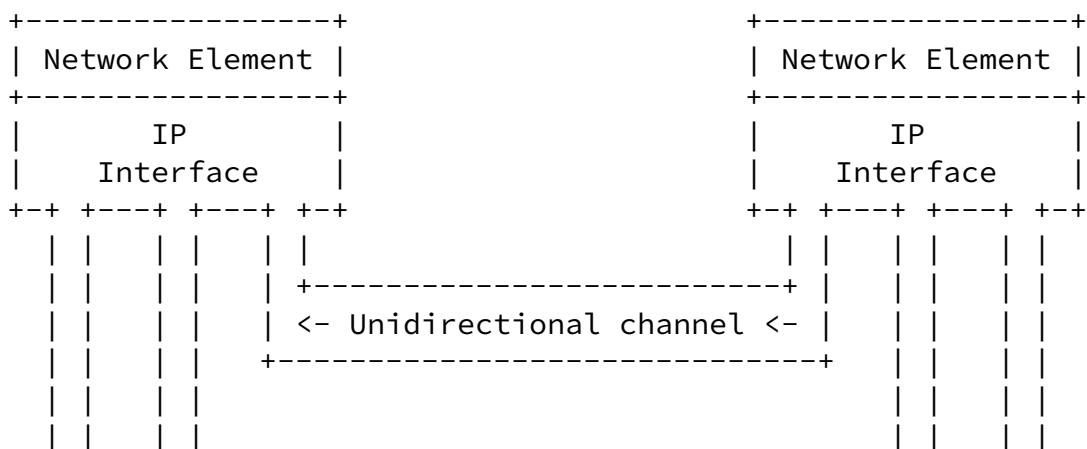

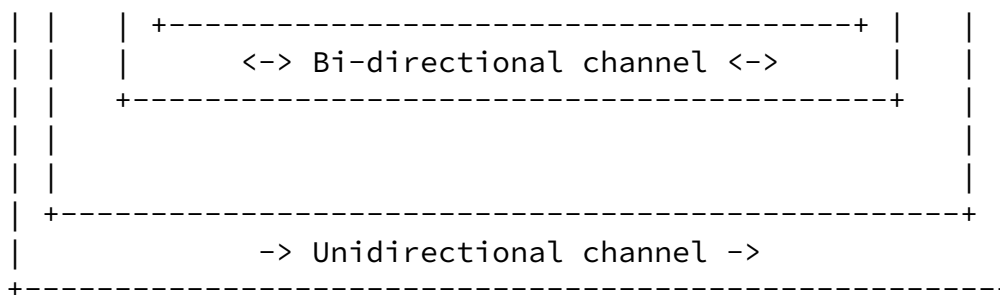

As mentioned above, a typical example of a multi-channel link is a cellular wireless link. In this example, header compression would be applicable on a per-channel basis, for each channel operating either in a bi-directional or unidirectional manner, depending on the channel properties.

#### [4.](#) ROHC Instances

For various purposes, such as network management on an IP interface implementing ROHC, it is necessary to identify the various ROHC entities that might be present on an interface. Such a minimal ROHC entity will from now on be referred to as a "ROHC instance". A ROHC instance can be one of two different types, either a "ROHC compressor" or a "ROHC decompressor" instance, and an IP interface can have N ROHC compressors and M ROHC decompressors, where N and M are arbitrary numbers. It should be noted that although a compressor is often co-located with a decompressor, a ROHC instance can never include both a compressor and a decompressor; where both are present, they will be referred to as two ROHC instances.

The following two subsections describe the two kinds of ROHC instances and their external interfaces, while sections [5](#) and [6](#) address how communication over these interfaces is realized through "ROHC channels" and "ROHC feedback channels". [Section 7](#) builds on top of the instance, channel and feedback channel concepts and clarifies how ROHC contexts map to this.

It should be noted that all figures in sections [4-6](#) have been rotated 90 degrees to simplify drawing, i.e. they do not show a "stack view".

##### [4.1.](#) ROHC Compressors

A ROHC compressor instance supports header compression according to one or several ROHC profiles. Apart from potential configuration or control interfaces, a compressor instance receives and sends data through 3 inputs and 1 output, as illustrated by the figure below:



**Uncompressed Input (UI):** Uncompressed packets are delivered from higher layers to the compressor through the UI.

**Compressed Output (CO):** Compressed packets are sent from the compressor through the CO, which is always connected to the input end of a ROHC channel (see [section 5](#)).

**Feedback Input (FI):** [optional] Feedback from the corresponding decompressor is received by the compressor through the FI, which (if present) is connected to the output end of a ROHC feedback channel of some kind (see [section 6](#)). When there are no means to transmit feedback from decompressor to compressor, FI is not used, and bi-directional compression will not be possible.

**Piggyback Input (PI):** [optional] If the compressor is associated with a co-located decompressor, for which the compressor delivers feedback to the other end of the link, feedback data for piggybacking is delivered to the compressor through the PI. If this input is used, it is connected to the FO of the co-located decompressor (see [section 4.2](#)).

---

INTERNET-DRAFT ROHC Terminology and Channel Mappings February 13, 2003

#### [4.2.](#) ROHC Decompressors

A ROHC decompressor instance supports header decompression according to one or several ROHC profiles. Apart from potential configuration or control interfaces, a decompressor instance receives and sends data through 1 input and 3 outputs, as illustrated by the figure below:

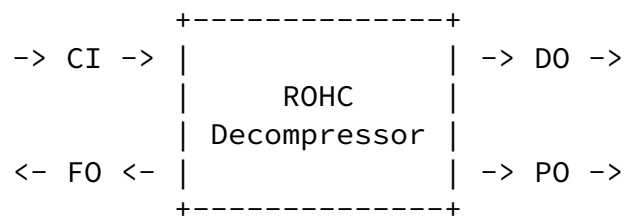

- Compressed Input (CI):** Compressed packets are received by the decompressor through the CI, which is always connected to the output end of a ROHC channel (see [section 5](#)).
- Decompressed Output (DO):** Decompressed packets are delivered from the decompressor to higher layers through the DO.
- Feedback Output (FO):** [optional] Feedback to the corresponding compressor is sent from the compressor through the FO, which (if present) is connected to the input end of a ROHC feedback channel of some kind (see [section 6](#)). When there are no means to transmit feedback from decompressor to compressor, FO is not used, and bi-directional compression will not be possible.
- Piggyback Output (PO):** [optional] If the decompressor is associated with a co-located compressor, to which the decompressor delivers feedback it receives piggybacked from the other end of the link, the received feedback data is delivered from the decompressor through the PO. If this output is used, it is connected to the FI of the co-located compressor (see [section 4.1](#)).

## 5. ROHC Channels

In [section 3](#), a general concept of channels was introduced. According to that definition, a channel is basically a logical point-to-point connection between the IP interfaces of two communicating network elements. By that definition, a channel represents the kind of logical connection needed to make header compression generally

applicable, and then the channel properties control whether compression can operate in a unidirectional or bi-directional manner.

The channel concept thus facilitates general header compression discussions, but since it groups unidirectional and bi-directional connections together it does not provide the means for describing details of how ROHC logically works. Therefore, for the case of ROHC, the channel concept is enhanced and a more restricted concept of "ROHC channels" is defined.

A ROHC channel has the same properties as a channel, with the difference that a ROHC channel is always unidirectional. A ROHC channel therefore has one single input endpoint, connected to the CO of one single ROHC compressor instance, and one single output endpoint, connected to the CI of one single ROHC decompressor instance. A ROHC channel must thus in this way be logically dedicated to one ROHC compressor and one ROHC decompressor, hereafter referred to as ROHC peers, creating a one-to-one mapping between a ROHC channel and two ROHC compressor/decompressor peers.

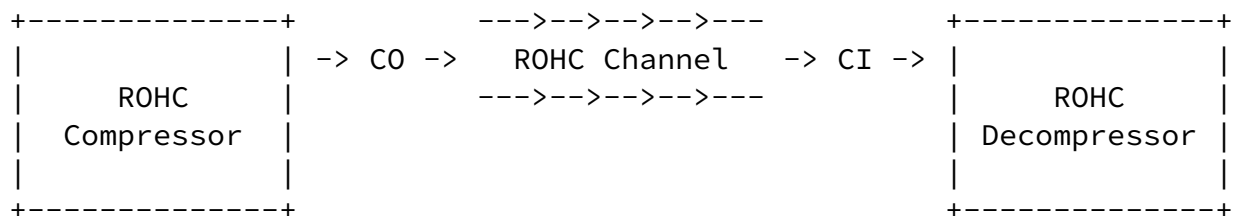

In many cases the lower layer channel is by nature bi-directional, but for ROHC communication over that channel, a ROHC channel would only represent one communication direction of that channel. For bi-directional channels, a common case would be to logically allocate one ROHC channel in each direction, allowing ROHC compression to be performed in both directions. The reason for defining ROHC channels

as unidirectional is basically to separate and generalize the concept of feedback, as described and exemplified in [section 6](#).

## 6. ROHC Feedback Channels

Since ROHC can be implemented over various kinds of links, unidirectional or bi-directional one-channel links as well as multi-channel links, the logical transmission of feedback from decompressor to compressor has been separated out from the transport of actual ROHC packets through the definition of ROHC channels as always being unidirectional from compressor to decompressor. This means that an additional channel concept must be defined for feedback, which is what will hereafter be referred to as "ROHC feedback channels".

In the same way as a ROHC channel is a logically dedicated unidirectional channel from a ROHC compressor to its corresponding ROHC peer decompressor, a ROHC feedback channel is a logically

dedicated unidirectional channel from a ROHC decompressor to its corresponding ROHC peer compressor. A ROHC feedback channel thus has one single input endpoint, connected to the FO of one single ROHC decompressor instance, and one single output endpoint, connected to the FI of one single ROHC compressor instance.

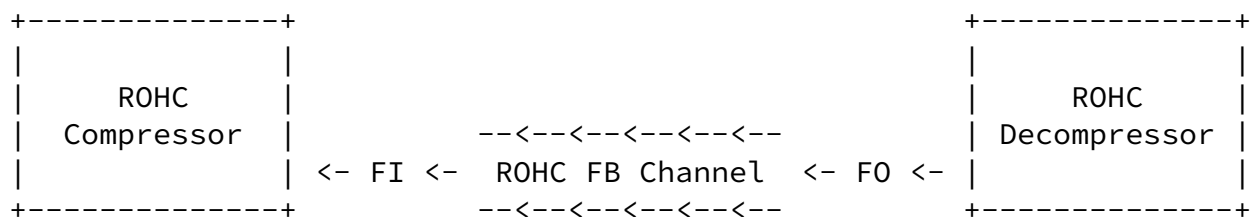

The reason for making this simplification and logically separate ROHC channels from ROHC feedback channels is generality for handling of feedback. ROHC has been designed with the assumption of logical separation, which creates flexibility in realizing feedback transport, as discussed in [RFC-3095, [section 5.2.1](#)]. There are no restrictions on how to implement a ROHC feedback channel, other than that it must be made available and be logically dedicated to the ROHC peers, if bi-directional compression operation is to be allowed.

The following subsections provide some, not at all exhaustive,



examples of how a ROHC feedback channel might possibly be realized.

### 6.1. Single-Channel Dedicated ROHC Feedback Channel Example

This section illustrates a one-way compression example where one bi-directional channel has been configured to represent a ROHC channel in one direction and a dedicated ROHC feedback channel in the other direction.

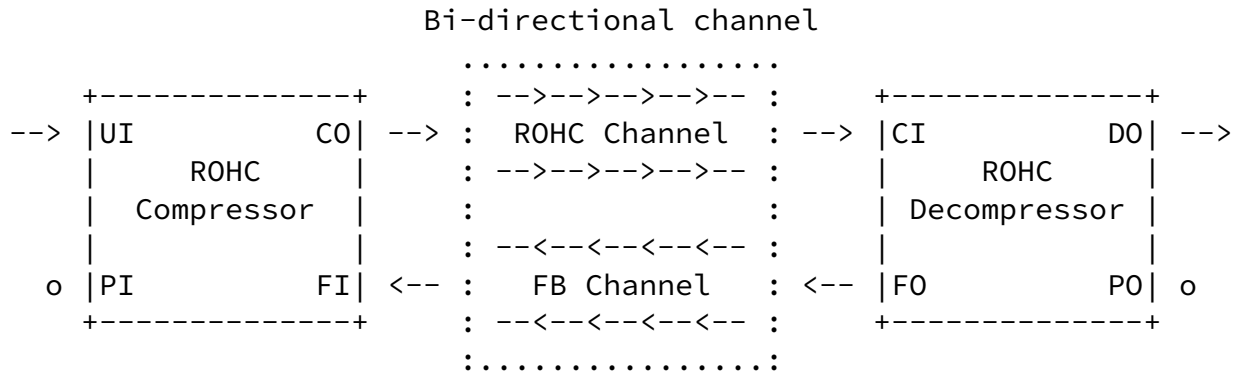

In this example, feedback is sent on its own dedicated channel, as discussed in e.g. feedback realization example 1-3 of ROHC [RFC-3095, page 44]. This means that the piggybacking/interspersing mechanism of ROHC is not used, and the PI/PO connections are thus left open (marked with a "o"). To facilitate communication with ROHC compression in a two-way manner using this approach, an identical configuration must be provided for the other direction, i.e. making use of four logical unidirectional channels.

### 6.2. Piggybacked/Interspersed ROHC Feedback Channel Example

This section illustrates how a bi-directional channel has been configured to represent one ROHC channel in each direction, while still allowing feedback to be transmitted through ROHC piggybacking and interspersing.

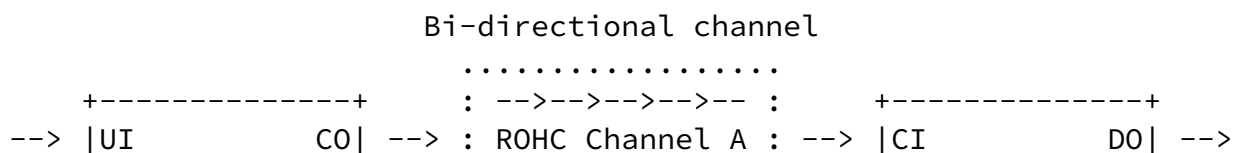

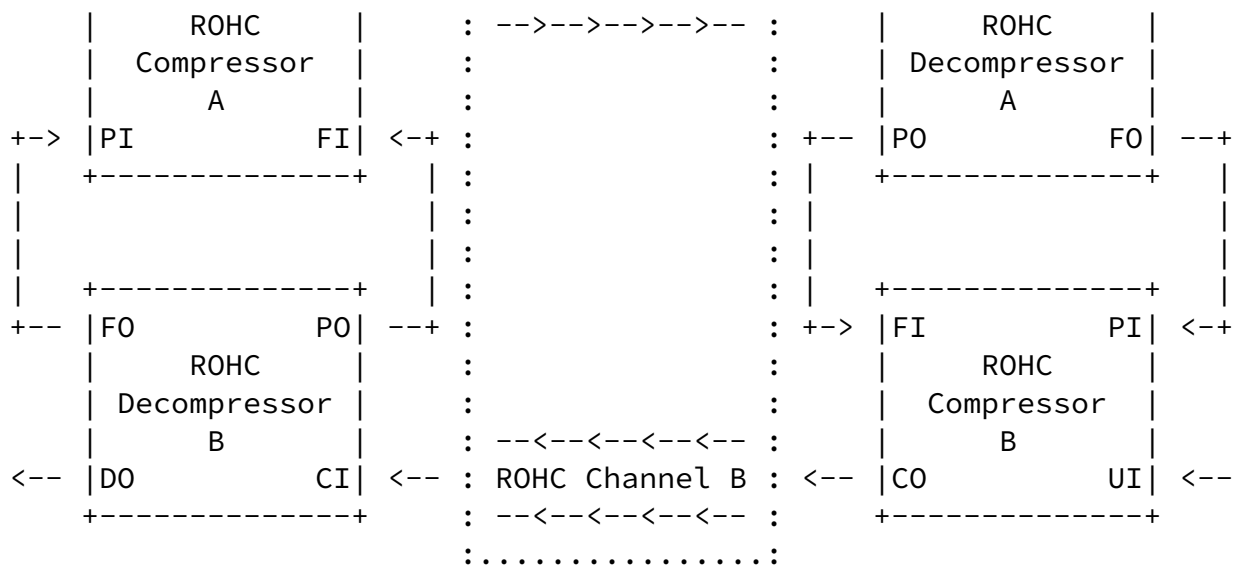

In this example, feedback is transmitted piggybacked or interspersed among compressed header packets in the ROHC channels, as discussed in e.g. feedback realization example 4-6 of ROHC [RFC-3095, page 44]. Feedback from decompressor A to compressor A is here sent through FO(A)->PI(B), piggybacked on a compressed packet over ROHC channel B, and delivered to compressor A through PO(B)->FI(A). A logical ROHC feedback channel is thus provided from the PI input at compressor B to the PO output at decompressor B. It should be noted that in this picture, PO and FO at the decompressors have been swapped to simplify drawing.

### 6.3. Dual-Channel Dedicated ROHC Feedback Channel Example

This section illustrates how two bi-directional channels have been

configured to represent two ROHC channels and two dedicated ROHC feedback channels, respectively.

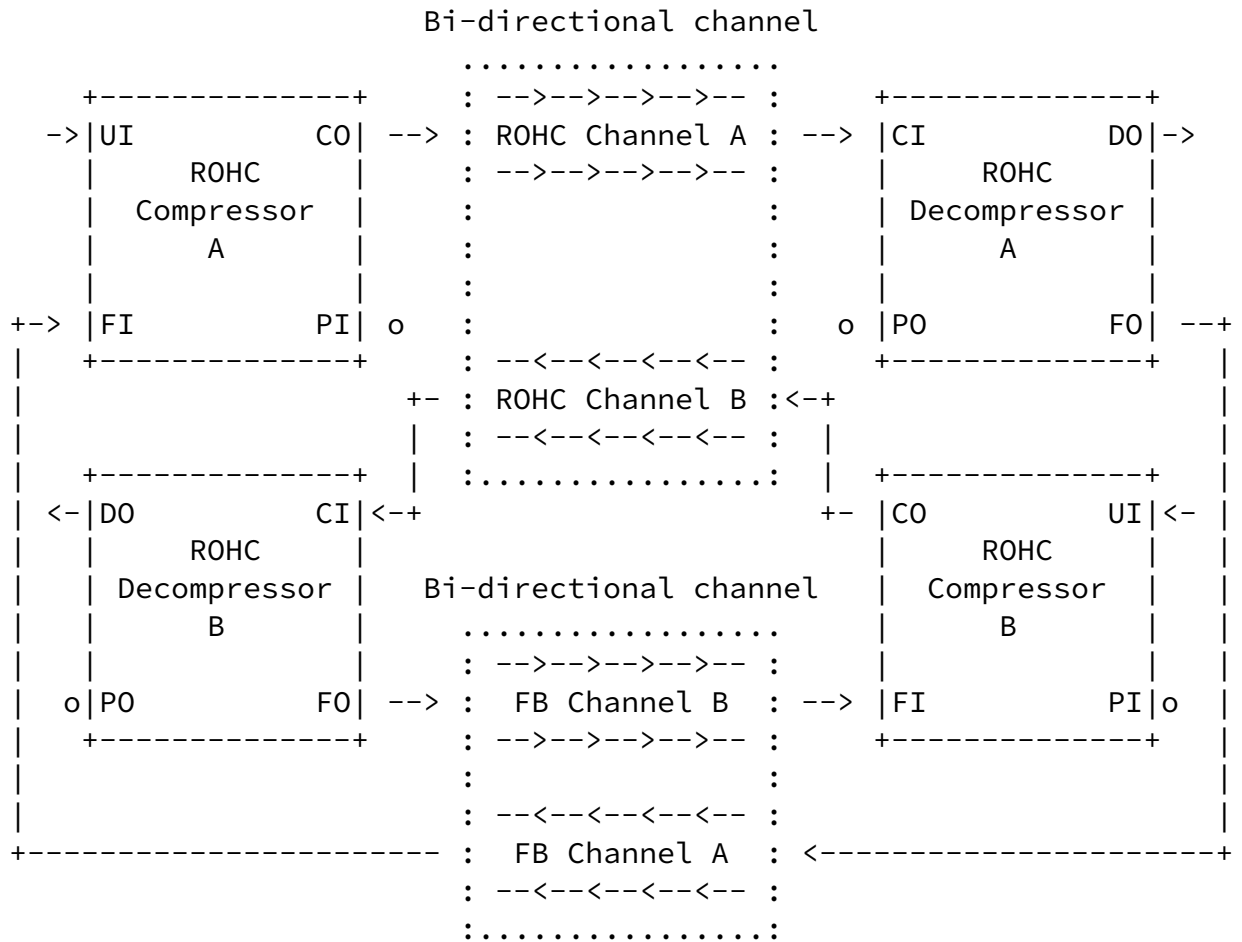

In this example, feedback is in both directions sent on its own dedicated channel, as discussed in e.g. feedback realization example 1-3 of ROHC [RFC-3095, page 44]. With this configuration, the piggybacking/interspersing mechanism of ROHC is not used, and the PI/PO connections are thus left open (marked with a "o"). It should be noted that in this picture FI/PI and PO/FO at the A-instances have been swapped to simplify drawing, while the B-instances have been horizontally mirrored.

INTERNET-DRAFT ROHC Terminology and Channel Mappings February 13, 2003

## 7. ROHC Contexts

In previous sections it has been clarified that one network element may have multiple IP interfaces, one IP interfaces may have multiple ROHC instances running (not necessarily both compressors and decompressors), and for each ROHC instance there is exactly one ROHC channel and optionally one ROHC feedback channel. How ROHC channels and ROHC feedback channels are realized will differ from case to case, depending on the actual layer two technology used.

Each compressor/decompressor can further compress/decompress an arbitrary (but limited) number of concurrent packet streams sent over the ROHC channel connected to that compressor/decompressor. Each packet stream relates to one particular context in the compressor/decompressor. When sent over the ROHC channel, compressed packets are labeled with a context identifier (CID), indicating which context the compressed packet corresponds to. There is thus a one-to-one mapping between the number of contexts that can be present in a compressor/decompressor and the context identifier (CID) space used in compressed packets over that ROHC channel. This is illustrated by the following figure:

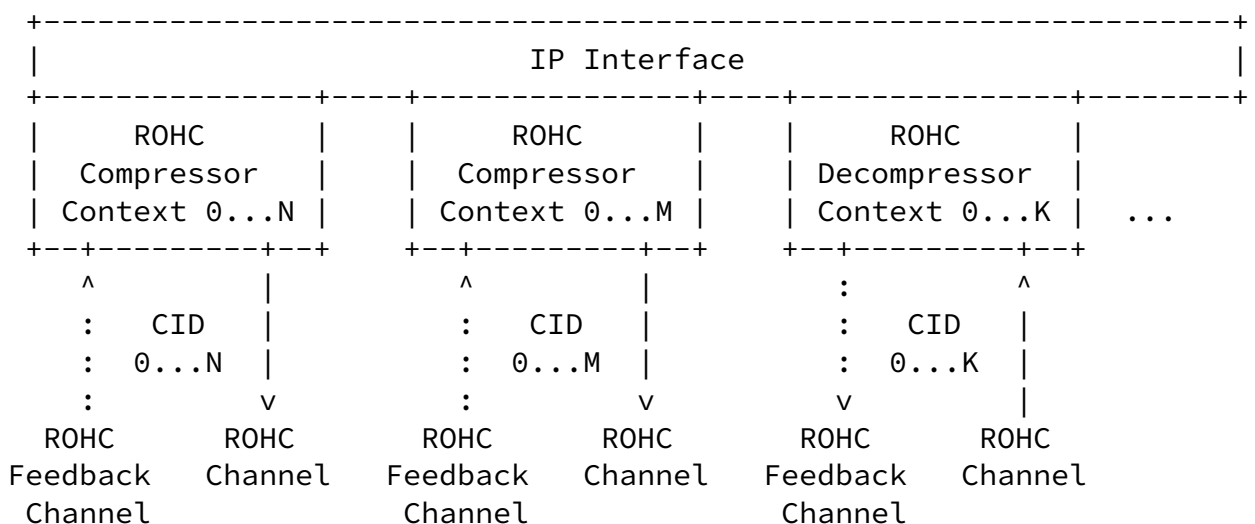

It should be noted that each ROHC instance at an IP interface therefore has its own context and CID space, and it must be ensured that the CID size of the corresponding decompressor at the other end of the ROHC channel is not smaller than the CID space of the compressor.

## 8. Summary

This document has introduced and defined a number of concepts and terms for use in ROHC network integration, and explained how the various pieces relate to each other. In the following bullet list, the most important relationship conclusions are repeated:

Jonsson

[Page 17]

---

INTERNET-DRAFT ROHC Terminology and Channel Mappings February 13, 2003

- A network element may have one or several IP interfaces.
- Each IP interface is connected to one or several logical layer two channels.
- Each IP interface may have one or several ROHC instances, either compressors, decompressors, or an arbitrary mix of both.
- For each ROHC instance, there is exactly one ROHC channel, and optionally exactly one ROHC feedback channel.
- How ROHC channels and ROHC feedback channels are realized through the available logical layer two channels will vary, and there is therefore no general relation between ROHC instances and logical layer two channels. ROHC instances map only to ROHC channels and ROHC feedback channels.
- Each compressor owns its own context identifier (CID) space, which is the multiplexing mechanism it uses when sending compressed header packets to its corresponding decompressor. That CID space thus defines how many compressed packet streams can be concurrently sent over the ROHC channel allocated to the compressor/decompressor peers.

## 9. Implementation Implications

This section will address how the conceptual aspects discussed above affect implementations of ROHC.

ROHC is defined as a general header compression framework on top of which compression profiles can be defined for each specific set of headers to compress. Although the framework holds a number of

important mechanisms, the separation between framework and profiles is mainly a separation from a standardization point of view, to indicate what must be common to all profiles, what must be defined by all profiles, and what is profile-specific details. To implement the framework as a separate module is thus not an obvious choice, especially if one wants to use profile implementations from different vendors. However, optimized implementations will probably separate the common parts and implement those in a ROHC framework module, and add profile modules to that.

A ROHC instance might thus consist of various pieces of implementation modules, profiles, and potentially also a common ROHC module, possibly from different vendors. If vendor and implementation version information is made available for network management purposes, this should thus be done on a per-profile basis, and in addition to that potentially also for the instance as a whole.

## 10. Security Considerations

This document is of an informative nature, and does not have any security aspects to address.

## 11. Acknowledgements

Thanks to Juergen Quittek, Hans Hannu, Carsten Bormann, and Ghyslain Pelletier for fruitful discussions, improvement suggestions, and review. Thanks also to Peter Eriksson for doing a language review.

## 12. References

[RFC-3095] Bormann, C., Burmeister, C., Degermark, M., Fukushima, H., Hannu, H., Jonsson, L-E., Hakenberg, R., Koren, T., Le, K., Liu, Z., Martensson, A., Miyazaki, A., Svanbro, K., Wiebke, T., Yoshimura, T. and H. Zheng, "Robust Header Compression (ROHC)", [RFC 3095](#), July 2001.

## 13. Author's Address

Lars-Erik Jonsson  
Ericsson AB  
Box 920  
SE-971 28 Lulea  
Sweden

Tel: +46 920 20 21 07  
Fax: +46 920 20 20 99

E-Mail: [lars-erik.jonsson@ericsson.com](mailto:lars-erik.jonsson@ericsson.com)

#### Full Copyright Statement

Copyright (C) The Internet Society (2003). All Rights Reserved.

This document and translations of it may be copied and furnished to others, and derivative works that comment on or otherwise explain it or assist in its implementation may be prepared, copied, published and distributed, in whole or in part, without restriction of any kind, provided that the above copyright notice and this paragraph are included on all such copies and derivative works. However, this document itself may not be modified in any way, such as by removing the copyright notice or references to the Internet Society or other Internet organizations, except as needed for the purpose of

developing Internet standards in which case the procedures for copyrights defined in the Internet Standards process must be followed, or as required to translate it into languages other than English.

The limited permissions granted above are perpetual and will not be revoked by the Internet Society or its successors or assigns.

This document and the information contained herein is provided on an "AS IS" basis and THE INTERNET SOCIETY AND THE INTERNET ENGINEERING TASK FORCE DISCLAIMS ALL WARRANTIES, EXPRESS OR IMPLIED, INCLUDING BUT NOT LIMITED TO ANY WARRANTY THAT THE USE OF THE INFORMATION HEREIN WILL NOT INFRINGE ANY RIGHTS OR ANY IMPLIED WARRANTIES OF MERCHANTABILITY OR FITNESS FOR A PARTICULAR PURPOSE.

This Internet-Draft expires August 13, 2003.