

Networking Working Group
Internet-Draft
Intended status: Standards Track
Expires: May 19, 2008

JP. Vasseur, Ed.
Cisco Systems, Inc
A. Ayyangar, Ed.
Juniper Networks, Inc
R. Zhang
BT
November 16, 2007

A Per-domain path computation method for establishing Inter-domain
Traffic Engineering (TE) Label Switched Paths (LSPs)
draft-ietf-ccamp-inter-domain-pd-path-comp-06

Status of this Memo

By submitting this Internet-Draft, each author represents that any applicable patent or other IPR claims of which he or she is aware have been or will be disclosed, and any of which he or she becomes aware will be disclosed, in accordance with [Section 6 of BCP 79](#).

Internet-Drafts are working documents of the Internet Engineering Task Force (IETF), its areas, and its working groups. Note that other groups may also distribute working documents as Internet-Drafts.

Internet-Drafts are draft documents valid for a maximum of six months and may be updated, replaced, or obsoleted by other documents at any time. It is inappropriate to use Internet-Drafts as reference material or to cite them other than as "work in progress."

The list of current Internet-Drafts can be accessed at <http://www.ietf.org/ietf/lid-abstracts.txt>.

The list of Internet-Draft Shadow Directories can be accessed at <http://www.ietf.org/shadow.html>.

This Internet-Draft will expire on May 19, 2008.

Copyright Notice

Copyright (C) The IETF Trust (2007).

Abstract

This document specifies a per-domain path computation technique for establishing inter-domain Traffic Engineering (TE) Multiprotocol Label Switching (MPLS) and Generalized MPLS (GMPLS) Label Switched Paths (LSPs). In this document a domain refers to a collection of

Internet-Draft

[draft-ietf-ccamp-inter-domain-pd-06](#)

November 2007

network elements within a common sphere of address management or path computational responsibility such as IGP areas and Autonomous Systems.

Per-domain computation applies where the full path of an inter-domain TE LSP cannot be or is not determined at the ingress node of the TE LSP, and is not signaled across domain boundaries. This is most likely to arise owing to TE visibility limitations. The signaling message indicates the destination and nodes up to the next domain boundary. It may also indicate further domain boundaries or domain identifiers. The path through each domain, possibly including the choice of exit point from the domain, must be determined within the domain.

Requirements Language

The key words "MUST", "MUST NOT", "REQUIRED", "SHALL", "SHALL NOT", "SHOULD", "SHOULD NOT", "RECOMMENDED", "MAY", and "OPTIONAL" in this document are to be interpreted as described in [RFC 2119](#) [[RFC2119](#)].

Internet-Draft

[draft-ietf-ccamp-inter-domain-pd-06](#)

November 2007

Table of Contents

1.	Terminology	4
2.	Introduction	4
3.	General assumptions	5
3.1.	Common assumptions	5
3.2.	Example of topology for the inter-area TE case	7
3.3.	Example of topology for the inter-AS TE case	8
4.	Per-domain path computation procedures	9
4.1.	Example with an inter-area TE LSP	13
4.1.1.	Case 1: T0 is a contiguous TE LSP	13
4.1.2.	Case 2: T0 is a stitched or nested TE LSP	14
4.2.	Example with an inter-AS TE LSP	14
4.2.1.	Case 1: T1 is a contiguous TE LSP	14
4.2.2.	Case 2: T1 is a stitched or nested TE LSP	15
5.	Path optimality/diversity	15
6.	Reoptimization of an inter-domain TE LSP	16
6.1.	Contiguous TE LSPs	17
6.2.	Stitched or nested (non-contiguous) TE LSPs	17
6.3.	Path characteristics after reoptimization	18
7.	IANA Considerations	18
8.	Security Considerations	18
9.	Acknowledgements	19
10.	References	19
10.1.	Normative References	19
10.2.	Informative References	20
	Authors' Addresses	21
	Intellectual Property and Copyright Statements	23

1. Terminology

Terminology used in this document

AS: Autonomous System.

ABR: Area Border Router: routers used to connect two IGP areas (areas in OSPF or levels in IS-IS).

ASBR: Autonomous System Border Router: routers used to connect together ASes of a different or the same Service Provider via one or more Inter-AS links.

Boundary LSR: a boundary LSR is either an ABR in the context of inter-area TE or an ASBR in the context of inter-AS TE.

ERO: Explicit Route Object

IGP: Interior Gateway Protocol

Inter-AS TE LSP: A TE LSP that crosses an AS boundary.

Inter-area TE LSP: A TE LSP that crosses an IGP area.

LSR: Label Switching Router.

LSP: Label Switched Path.

TE LSP: Traffic Engineering Label Switched Path.

PCE: Path Computation Element: an entity (component, application or network node) that is capable of computing a network path or route based on a network graph and applying computational constraints.

TED: Traffic Engineering Database.

The notion of contiguous, stitched and nested TE LSPs is defined in [\[RFC4726\]](#) and will not be repeated here.

[2.](#) Introduction

The requirements for inter-domain Traffic Engineering (inter-area and inter-AS TE) have been developed by the Traffic Engineering Working Group and have been stated in [\[RFC4105\]](#) and [\[RFC4216\]](#). The framework for inter-domain MPLS Traffic Engineering has been provided in [\[RFC4726\]](#).

Vasseur, et al.

Expires May 19, 2008

[Page 4]

Internet-Draft

[draft-ietf-ccamp-inter-domain-pd-06](#)

November 2007

Some of the mechanisms used to establish and maintain inter-domain TE LSPs are specified in [\[I-D.ietf-ccamp-inter-domain-rsvp-te\]](#) and [\[I-D.ietf-ccamp-lsp-stitching\]](#).

This document exclusively focuses on the path computation aspects and defines a method for establishing inter-domain TE LSP where each node in charge of computing a section of an inter-domain TE LSP path is always along the path of such TE LSP.

When the visibility of an end to end complete path spanning multiple domains is not available at the Head-end LSR (LSR that initiated the TE LSP), one approach described in this document consists of using a per-domain path computation technique during LSP setup to determine the inter-domain TE LSP as it traverses multiple domains.

The mechanisms proposed in this document are also applicable to MPLS TE domains other than IGP areas and ASs.

The solution described in this document does not attempt to address all the requirements specified in [\[RFC4105\]](#) and [\[RFC4216\]](#). This is acceptable according to [\[RFC4216\]](#) which indicates that a solution may be developed to address a particular deployment scenario and might,

therefore, not meet all requirements for other deployment scenarios.

It must be pointed out that the inter-domain path computation technique proposed in this document is one among many others and the choice of the appropriate technique must be driven by the set of requirements for the paths attributes and the applicability to a particular technique with respect to the deployment scenario. For example, if the requirement is to get an end-to-end constraint-based shortest path across multiple domains, then a mechanism using one or more distributed PCEs could be used to compute the shortest path across different domains (see [[RFC4655](#)]). Other offline mechanisms for path computation are not precluded either. Note also that a Service Provider may elect to use different inter-domain path computation techniques for different TE LSP types.

3. General assumptions

3.1. Common assumptions

- Each domain in all the examples below is assumed to be capable of doing Traffic Engineering (i.e. running OSPF-TE or ISIS-TE and RSVP-TE). A domain may itself comprise multiple other domains. E.g. An AS may itself be composed of several other sub-AS(es) (BGP confederations) or areas/levels. In this case, the path computation technique described for inter-area and inter-AS MPLS Traffic

Engineering just recursively applies.

- The inter-domain TE LSPs are signaled using RSVP-TE ([[RFC3209](#)] and [[RFC3473](#)]).
- The path (specified by an ERO (Explicit Route Object) in an RSVP-TE Path message)) for an inter-domain TE LSP may be signaled as a set of (loose and/or strict) hops.
- The hops may identify:
 - * The complete strict path end-to-end across different domains
 - * The complete strict path in the source domain followed by boundary LSRs (or domain identifiers, e.g. AS numbers)

- * The complete list of boundary LSRs along the path
- * The current boundary LSR and the LSP destination.

The set of (loose or strict) hops can either be statically configured on the Head-end LSR or dynamically computed. A per-domain path computation method is defined in this document with an optional Auto-discovery mechanism based on IGP, BGP, policy routing information yielding the next-hop boundary node (domain exit point, such as Area Border Router (ABR) or an Autonomous System Border Router (ASBR) along the path as the TE LSP is being signaled, along with potential crankback mechanisms. Alternatively the domain exit points may be statically configured on the Head-end LSR in which case next-hop boundary node auto-discovery would not be required.

- Boundary LSRs are assumed to be capable of performing local path computation for expansion of a loose next-hop in the signaled ERO if the path is not signaled by the Head-end LSR as a set of strict hops or if the strict hop is an abstract node (e.g. an AS). In any case, no topology or resource information needs to be distributed between domains (as mandated per [\[RFC4105\]](#) and [\[RFC4216\]](#)), which is critical to preserve IGP/BGP scalability and confidentiality in the case of TE LSPs spanning multiple routing domains.

- The paths for the intra-domain Hierarchical LSPs (H-LSP) or Stitched LSPs (S-LSP) or for a contiguous TE LSP within the domain may be pre-configured or computed dynamically based on the arriving inter-domain LSP setup request (depending on the requirements of the transit domain). Note that this capability is explicitly specified as a requirement in [\[RFC4216\]](#). When the paths for the H-LSPs/S-LSP are pre-configured, the constraints as well as other parameters like local protection scheme for the intra-domain H-LSP/S-LSP are also

pre-configured.

- While certain constraints like bandwidth can be used across different domains, certain other TE constraints like resource affinity, color, metric, etc. as listed in [\[RFC2702\]](#) may need to be translated at domain boundaries. If required, it is assumed that, at the domain boundary LSRs, there will exist some sort of local mapping based on policy agreement in order to translate such constraints

across domain boundaries. It is expected that such an assumption particularly applies to inter-AS TE: for example, the local mapping would be similar to the Inter-AS TE Agreement Enforcement Policies stated in [[RFC4216](#)].

- The procedures defined in this document are applicable to any node (not just boundary node) that receives a Path message with an ERO that contains a loose hop or an abstract node that is not a simple abstract node (that is, an abstract node that identifies more than one LSR).

[3.2.](#) Example of topology for the inter-area TE case

The following example will be used for the inter-area TE case in this document.

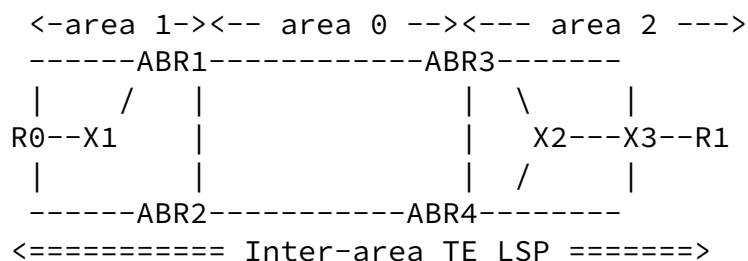

Figure 1 - Example of topology for the inter-area TE case

Description of Figure 1:

- ABR1, ABR2, ABR3 and ABR4 are ABRs,
- X1: an LSR in area 1,
- X2, X3: LSRs in area 2,
- An inter-area TE LSP T0 originated at R0 in area 1 and terminating at R1 in area 2.

Notes:

- The terminology used in the example above corresponds to OSPF but the path computation technique proposed in this document equally applies to the case of an IS-IS multi-level network.

- Just a few routers in each area are depicted in the diagram above

for the sake of simplicity.

- The example depicted in Figure 1 shows the case where the Head-end and Tail-end areas are connected by means of area 0. The case of an inter-area TE LSP between two IGP areas that does not transit through area 0 is not precluded.

3.3. Example of topology for the inter-AS TE case

We consider the following general case, built on a superset of the various scenarios defined in [RFC4216]:

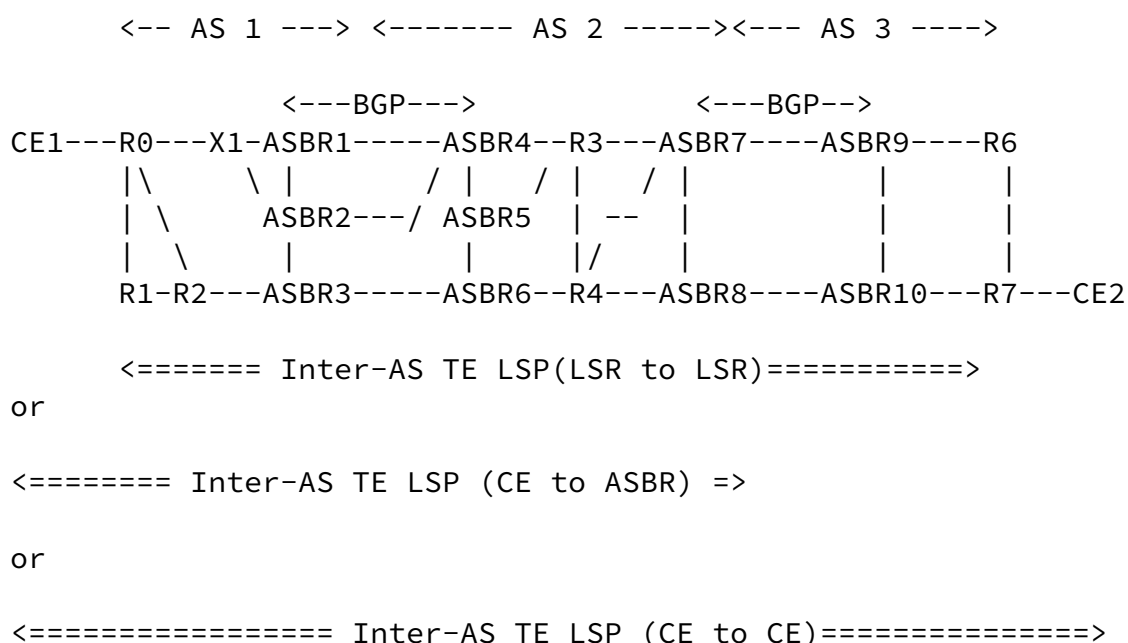

Figure 2 - Example of topology for the inter-AS TE case

The diagram depicted in Figure 2 covers all the inter-AS TE deployment cases described in [RFC4216].

Description of Figure 2:

- Three interconnected ASs, respectively AS1, AS2, and AS3. Note that in some scenarios described in [RFC4216] AS1=AS3.
- The ASBRs in different ASs are BGP peers. There is usually no IGP running on the single hop links interconnecting the ASBRs and also referred to as inter-ASBR links.
- Each AS runs an IGP (IS-IS or OSPF) with the required IGP TE extensions (see [RFC3630], [RFC3784], [RFC4203] and [RFC4205]). In

other words, the ASes are TE enabled,

- Each AS can be made of several IGP areas. The path computation technique described in this document applies to the case of a single AS made of multiple IGP areas, multiples ASs made of a single IGP areas or any combination of the above. For the sake of simplicity, each routing domain will be considered as single area in this document. The case of an Inter-AS TE LSP spanning multiple ASs where some of those ASs are themselves made of multiple IGP areas can be easily derived from the examples above: the per-domain path computation technique described in this document is applied recursively in this case.

- An inter-AS TE LSP T1 originated at R0 in AS1 and terminating at R6 in AS3.

[4.](#) Per-domain path computation procedures

The mechanisms for inter-domain TE LSP computation as described in this document can be used regardless of the nature of the inter-domain TE LSP (contiguous, stitched or nested).

Note that any path can be defined as a set of loose and strict hops. In other words, in some cases, it might be desirable to rely on the dynamic path computation in some domain, and exert a strict control on the path in other domains (defining strict hops).

When an LSR that is a boundary node such as an ABR/ASBR receives a Path message with an ERO that contains a strict node, the procedures specified in [[RFC3209](#)] apply and no further action is needed.

When an LSR that is a boundary node such as an ABR/ASBR receives a Path message with an ERO that contains a loose hop or an abstract node that is not a simple abstract node (that is, an abstract node that identifies more than one LSR), then it MUST follow the procedures as described in [[I-D.ietf-ccamp-inter-domain-rsvp-te](#)].

In addition, the following procedures describe the path computation procedures that SHOULD be carried out on the LSR:

- 1) If the next hop is not present in the TED, the two following conditions MUST be checked:
 - o If the IP address of the next hop boundary LSR is outside of the current domain,

- o If the next hop domain is PSC (Packet Switch Capable) and uses in-band control channel

If the two conditions above are satisfied then the boundary LSR SHOULD check if the next-hop has IP reachability (via IGP or BGP). If the next-hop is not reachable, then a signaling failure occurs and the LSR SHOULD send back an RSVP PathErr message upstream with error code=24 ("Routing Problem") and error subcode as described in [section 4.3.4 of \[RFC3209\]](#). If the available routing information indicates that next-hop is reachable, the selected route will be expected to pass through a domain boundary via a domain boundary LSR. The determination of domain boundary point based on routing information is what we term as "auto-discovery" in this document. In the absence of such an auto-discovery mechanism, a) the ABR in the case of inter-area TE or the ASBR in the next-hop AS in the case of inter-AS TE should be the signaled loose next-hop in the ERO and hence should be accessible via the TED or b) there needs to be an alternate scheme that provides the domain exit points. Otherwise the path computation for the inter-domain TE LSP will fail.

An implementation MAY support the ability to disable such IP reachability fall-back option should the next hop boundary LSR not be present in the TED. In other words, an implementation MAY support the possibility to trigger a signaling failure whenever the next-hop is not present in the TED.

2) Once the next-hop boundary LSR has been determined (according to the procedure described in 1)) or if the next-hop boundary is present in the TED

- o Case of a contiguous TE LSP. Unless not allowed by policy, the boundary LSR that processes the ERO SHOULD perform an ERO expansion (process consisting of computing the constrained path up to the next loose hop and add the list of hops as strict nodes in the ERO). If no path satisfying the set of constraints can be found, then this is treated as a path computation and signaling failure and an RSVP PathErr message SHOULD be sent for the inter-domain TE LSP based on [section 4.3.4 of \[RFC3209\]](#).

- o Case of stitched or nested LSP
 - * If the boundary LSR is a candidate LSR for intra-area H-LSP/S-LSP setup (the boundary has local policy for nesting or stitching), the TE LSP is a candidate for hierarchy/nesting (the "Contiguous LSP" bit defined in [\[I-D.ietf-ccamp-inter-domain-rsvp-te\]](#) is not set) and if there is no H-LSP/S-LSP from this LSR to the next-hop boundary LSR that satisfies the constraints, it SHOULD signal a H-LSP/S-LSP

to the next-hop boundary LSR. If pre-configured H-LSP(s) or S-LSP(s) already exist, then it will try to select from among those intra-domain LSPs. Depending on local policy, it MAY signal a new H-LSP/S-LSP if this selection fails. If the H-LSP/S-LSP is successfully signaled or selected, it propagates the inter-domain Path message to the next-hop following the procedures described in [\[I-D.ietf-ccamp-inter-domain-rsvp-te\]](#). If, for some reason the dynamic H-LSP/S-LSP setup to the next-hop boundary LSR fails, then this SHOULD be treated as a path computation and signaling failure and an RSVP PathErr message SHOULD be sent upstream for the inter-domain LSP. Similarly, if selection of a preconfigured H-LSP/S-LSP fails and local policy prevents dynamic H-LSP/S this SHOULD be treated as a path computation and signaling failure and an RSVP PathErr SHOULD be sent upstream for the inter-domain TE LSP. In both these cases procedures described in [section 4.3.4 of \[RFC3209\]](#) SHOULD be followed to handle the failure.

- * If, however, the boundary LSR is not a candidate for intra-domain H-LSP/S-LSP (the boundary LSR does not have local policy for nesting or stitching) or the TE LSP is a not candidate for hierarchy/nesting (the "Contiguous LSP" bit defined in [\[I-D.ietf-ccamp-inter-domain-rsvp-te\]](#) is set), then it SHOULD apply the same procedure as for the contiguous case.

The ERO of an inter-domain TE LSP may comprise abstract nodes such as ASes. In such a case, upon receiving the ERO whose next hop is an AS, the boundary LSR has to determine the next-hop boundary LSR which may be determined based on the "auto-discovery" process mentioned above. If multiple ASBRs candidates exist the boundary LSR may apply some policies based on peering contracts that may have been pre-negotiated. Once the next-hop boundary LSR has been determined a

similar procedure as the one described above is followed.

Note related to the inter-AS TE case:

In terms of computation of an inter-AS TE LSP path, an interesting optimization technique consists of allowing the ASBRs to flood the TE information related to the inter-ASBR link(s) although no IGP TE is enabled over those links (and so there is no IGP adjacency over the inter-ASBR links). This of course implies for the inter-ASBR links to be TE-enabled although no IGP is running on those links.

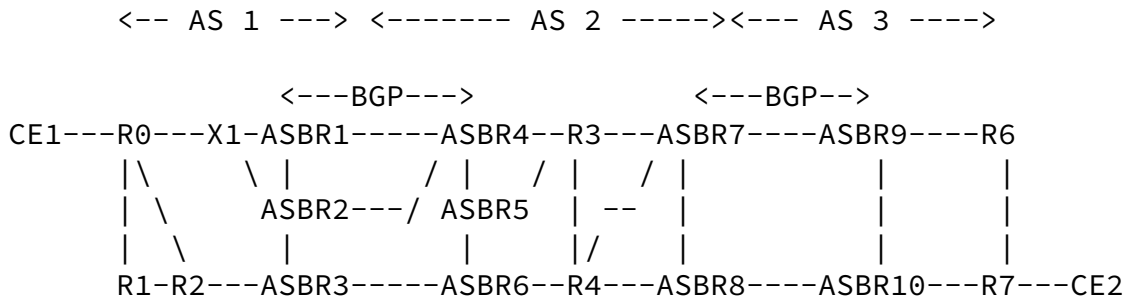

Figure 3 - Flooding of the TE-related information for the Inter-ASBR links

Referring to figure 3, ASBR1 for example would advertise in its OSPF LSA/IS-IS LSP the Traffic Engineering TLVs related to the link ASBR1-ASBR4.

This allows an LSR (could be entry ASBR) in the previous AS to make a more appropriate route selection up to the entry ASBR in the immediately downstream AS taking into account the constraints associated with the inter-ASBR links. This reduces the risk of call set up failure due to inter-ASBR links not satisfying the inter-AS TE LSP set of constraints. Note that the TE information is only related to the inter-ASBR links: the TE LSA/LSP flooded by the ASBR includes not only the TE-enabled links contained in the AS but also the inter-ASBR links.

Note that no summarized TE information is leaked between ASes which is compliant with the requirements listed in [[RFC4105](#)] and [[RFC4216](#)].

For example, consider the diagram depicted in Figure 2: when ASBR1 floods its IGP TE LSA ((opaque LSA for OSPF)/LSP (TLV 22 for IS-IS)) in its routing domain, it reflects the reservation states and TE properties of the following links: X1-ASBR1, ASBR1-ASBR2 and ASBR1-ASBR4.

Thanks to such an optimization, the inter-ASBRs TE link information corresponding to the links originated by the ASBR is made available in the TED of other LSRs in the same domain that the ASBR belongs to. Consequently, the path computation for an inter-AS TE LSP path can also take into account the inter-ASBR link(s). This will improve the chance of successful signaling along the next AS in case of resource shortage or unsatisfied constraints on inter-ASBR links and it potentially reduces one level of crankback. Note that no topology information is flooded and these links are not used in IGP SPF computations. Only the TE information for the outgoing links directly connected to the ASBR is advertised.

Note that an Operator may decide to operate a stitched segment or 1-hop hierarchical LSP for the inter-ASBR link.

[4.1.](#) Example with an inter-area TE LSP

The following example uses figure 1 as a reference.

[4.1.1.](#) Case 1: T0 is a contiguous TE LSP

The Head-end LSR (R0) first determines the next hop ABR (which could be manually configured by the user or dynamically determined by using auto-discovery mechanism). R0 then computes the path to reach the selected next hop ABR (ABR1) and signals the Path message. When the Path message reaches ABR1, it first determines the next hop ABR from its area 0 along the LSP path (say ABR3), either directly from the ER0 (if for example the next hop ABR is specified as a loose hop in the ER0) or by using the auto-discovery mechanism specified above.

- Example 1 (set of loose hops): R0-ABR1(loose)-ABR3(loose)-R1(loose)
- Example 2 (mix of strict and loose hops): R0-X1-ABR1-ABR3(loose)-

Note that a set of paths can be configured on the Head-end LSR, ordered by priority. Each priority path can be associated with a different set of constraints. It may be desirable to systematically have a last resort option with no constraint to ensure that the inter-area TE LSP could always be set up if at least a TE path exists between the inter-area TE LSP source and destination. In case of set up failure or when an RSVP PathErr is received indicating the TE LSP has suffered a failure, an implementation might support the possibility to retry a particular path option configurable amount of times (optionally with dynamic intervals between each trial) before trying a lower priority path option.

Once it has computed the path up to the next hop ABR (ABR3), ABR1 sends the Path message along the computed path. Upon receiving the Path message, ABR3 then repeats a similar procedure. If ABR3 cannot find a path obeying the set of constraints for the inter-area TE LSP, the signaling process stops and ABR3 sends a PathErr message to ABR1. Then ABR1 can in turn trigger a new path computation by selecting another egress boundary LSR (ABR4 in the example above) if crankback is allowed for this inter-area TE LSP (see [[I-D.ietf-ccamp-crankback](#)]). If crankback is not allowed for that inter-area TE LSP or if ABR1 has been configured not to perform crankback, then ABR1 MUST stop the signaling process and MUST forward a PathErr up to the Head-end LSR (R0) without trying to select another ABR.

[4.1.2.](#) Case 2: T0 is a stitched or nested TE LSP

The Head-end LSR (R0) first determines the next hop ABR (which could be manually configured by the user or dynamically determined by using auto-discovery mechanism). R0 then computes the path to reach the selected next hop ABR and signals the Path message. When the Path message reaches ABR1, it first determines the next hop ABR from its area 0 along the LSP path (say ABR3), either directly from the ERO (if for example the next hop ABR is specified as a loose hop in the ERO) or by using an auto-discovery mechanism, specified above.

ABR1 then checks if it has a H-LSP or S-LSP to ABR3 matching the constraints carried in the inter-area TE LSP Path message. If not, ABR1 computes the path for a H-LSP or S-LSP from ABR1 to ABR3 satisfying the constraint and sets it up accordingly. Note that the H-LSP or S-LSP could have also been pre-configured.

Once ABR1 has selected the H-LSP/S-LSP for the inter-area LSP, using the signaling procedures described in [\[I-D.ietf-ccamp-inter-domain-rsvp-te\]](#), ABR1 sends the Path message for inter-area TE LSP to ABR3. Note that irrespective of whether ABR1 does nesting or stitching, the Path message for the inter-area TE LSP is always forwarded to ABR3. ABR3 then repeats the exact same procedures. If ABR3 cannot find a path obeying the set of constraints for the inter-area TE LSP, ABR3 sends a PathErr message to ABR1. Then ABR1 can in turn either select another H-LSP/S-LSP to ABR3 if such an LSP exists or select another egress boundary LSR (ABR4 in the example above) if crankback is allowed for this inter-area TE LSP (see [\[I-D.ietf-ccamp-crankback\]](#)). If crankback is not allowed for that inter-area TE LSP or if ABR1 has been configured not to perform crankback, then ABR1 forwards the PathErr up to the inter-area Head-end LSR (R0) without trying to select another egress LSR.

[4.2.](#) Example with an inter-AS TE LSP

The following example uses figure 2 as a reference.

The path computation procedures for establishing an inter-AS TE LSP are very similar to those of an inter-area TE LSP described above. The main difference is related to the presence of inter-ASBRs link(s).

[4.2.1.](#) Case 1: T1 is a contiguous TE LSP

The inter-AS TE path may be configured on the Head-end LSR as a set of strict hops, loose hops or a combination of both.

- Example 1 (set of loose hops): ASBR4(loose)-ASBR9(loose)-R6(loose)

- Example 2 (mix of strict and loose hops): R2-ASBR3-ASBR2-ASBR1-ASBR4-ASBR10(loose)-ASBR9-R6

In the example 1 above, a per-AS path computation is performed,

respectively on R0 for AS1, ASBR4 for AS2 and ASBR9 for AS3. Note that when an LSR has to perform an ERO expansion, the next hop must either belong to the same AS, or must be the ASBR directly connected to the next hops AS. In this later case, the ASBR reachability is announced in the IGP TE LSA/LSP originated by its neighboring ASBR. In the example 1 above, the TE LSP path is defined as: ASBR4(loose)-ASBR9(loose)-R6(loose). This implies that R0 must compute the path from R0 to ASBR4, hence the need for R0 to get the TE reservation state related to the ASBR1-ASBR4 link (flooded in AS1 by ASBR1). In addition, ASBR1 must also announce the IP address of ASBR4 specified in the T1's path configuration.

Once it has computed the path up to the next hop ASBR, ASBR1 sends the Path message for the inter-area TE LSP to ASBR4 (supposing that ASBR4 is the selected next hop ASBR). ASBR4 then repeats the exact same procedures. If ASBR4 cannot find a path obeying the set of constraints for the inter-AS TE LSP, then ASBR4 sends a PathErr message to ASBR1. Then ASBR1 can in turn either select another ASBR (ASBR5 in the example above) if crankback is allowed for this inter-AS TE LSP (see [[I-D.ietf-ccamp-crankback](#)]). If crankback is not allowed for that inter-AS TE LSP or if ASBR1 has been configured not to perform crankback, ASBR1 stops the signaling process and forwards a PathErr up to the Head-end LSR (R0) without trying to select another egress LSR. In this case, the Head-end LSR can in turn select another sequence of loose hops, if configured. Alternatively, the Head-end LSR may decide to retry the same path; this can be useful in case of set up failure due an outdated IGP TE database in some downstream AS. An alternative could also be for the Head-end LSR to retry to same sequence of loose hops after having relaxed some constraint(s).

[4.2.2.](#) Case 2: T1 is a stitched or nested TE LSP

The path computation procedures are very similar to the inter-area LSP setup case described earlier. In this case, the H-LSPs or S-LSPs are originated by the ASBRs at the entry to the AS.

[5.](#) Path optimality/diversity

Since the inter-domain TE LSP is computed on a per domain (area, AS) basis, one cannot guarantee that the optimal inter-domain path can be found.

Moreover, computing two diverse paths using a per-domain path computation approach may not be possible in some topologies (due to the well-known 'trapping' problem).

For example, consider the following simple topology:

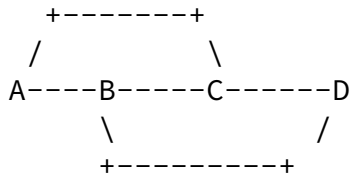

Figure 4 - Example of "trapping" problem

In the simple topology depicted in figure 3, with a serialized approach using the per-domain path computation technique specified in this document, a first TE LSP may be computed following the path A-B-C-D, in which case no diverse path could be found although two diverse paths actually exist: A-C-D and A-B-D. The aim of that simple example that can easily be extended to the inter-domain case is to illustrate the potential issue of not being able to find diverse paths using the per-domain path computation approach when diverse paths exist.

As already pointed out, the required path computation method can be selected by the Service Provider on a per LSP basis.

If the per-domain path computation technique does not meet the set of requirements for a particular TE LSP (e.g. path optimality, requirements for a set of diversely routed TE LSPs, ...) other techniques such as PCE-based path computation techniques may be used (see [[RFC4655](#)]).

6. Reoptimization of an inter-domain TE LSP

As stated in [[RFC4216](#)] and in [[RFC4105](#)], the ability to reoptimize an already established inter-domain TE LSP constitutes a requirement. The reoptimization process significantly differs based upon the nature of the TE LSP and the mechanism in use for the TE LSP computation.

The following mechanisms can be used for reoptimization and are dependent on the nature of the inter-domain TE LSP.

[6.1.](#) Contiguous TE LSPs

After an inter-domain TE LSP has been set up, a more optimal route might appear within any traversed domain. Then in this case, it is desirable to get the ability to reroute an inter-domain TE LSP in a non-disruptive fashion (making use of the so-called Make-Before-Break procedure) to follow such more optimal path. This is known as a TE LSP reoptimization procedure.

[RFC4736] proposes a mechanism that allows the Head-end LSR to be notified of the existence of a more optimal path in a downstream domain. The Head-end LSR may then decide to gracefully reroute the TE LSP using the so-called Make-Before-Break procedure. In case of a contiguous LSP, the reoptimization process is strictly controlled by the Head-end LSR which triggers the make-before-break procedure as defined in [\[RFC3209\]](#), regardless of the location of the more optimal path.

[6.2.](#) Stitched or nested (non-contiguous) TE LSPs

In the case of a stitched or nested inter-domain TE LSP, the reoptimization process is treated as a local matter to any domain. The main reason is that the inter-domain TE LSP is a different LSP (and therefore different RSVP session) from the intra-domain S-LSP or H-LSP in an area or an AS. Therefore, reoptimization in a domain is done by locally reoptimizing the intra-domain H-LSP or S-LSP. Since the inter-domain TE LSPs are transported using S-LSP or H-LSP across each domain, optimality of the inter-domain TE LSP in a domain is dependent on the optimality of the corresponding S-LSP or H-LSPs. If, after an inter-domain LSP is setup, a more optimal path is available within an domain, the corresponding S-LSP or H-LSP will be reoptimized using "Make-Before-Break" techniques discussed in [\[RFC3209\]](#). Reoptimization of the H-LSP or S-LSP automatically reoptimizes the inter-domain TE LSPs that the H-LSP or the S-LSP transports. Reoptimization parameters like frequency of reoptimization, criteria for reoptimization like metric or bandwidth availability, etc can vary from one domain to another and can be configured as required, per intra-domain TE S-LSP or H-LSP if it is preconfigured or based on some global policy within the domain.

Hence, in this scheme, since each domain takes care of reoptimizing its own S-LSPs or H-LSPs, and therefore the corresponding inter-domain TE LSPs, the Make-Before-Break can happen locally and is not triggered by the Head-end LSR for the inter-domain LSP. So, no additional RSVP signaling is required for LSP reoptimization and reoptimization is transparent to the Head-end LSR of the inter-domain TE LSP.

If, however, an operator desires to manually trigger reoptimization at the Head-end LSR for the inter-domain TE LSP, then this solution does not prevent that. A manual trigger for reoptimization at the Head-end LSR SHOULD force a reoptimization thereby signaling a "new" path for the same LSP (along the more optimal path) making use of the Make-Before-Break procedure. In response to this new setup request, the boundary LSR may either initiate new S-LSP setup, in case the inter-domain TE LSP is being stitched to the intra-domain S-LSP or it may select an existing or new H-LSP in case of nesting. When the LSP setup along the current path is complete, the Head-end LSR should switchover the traffic onto that path and the old path is eventually torn down. Note that the Head-end LSR does not know a priori whether a more optimal path exists. Such a manual trigger from the Head-end LSR of the inter-domain TE LSP is, however, not considered to be a frequent occurrence.

Procedures described in [[RFC4736](#)] MUST be used if the operator does not desire local reoptimization of certain inter-domain LSPs. In this case, any reoptimization event within the domain MUST be reported to the Head-end node. This SHOULD be a configurable policy.

[6.3](#). Path characteristics after reoptimization

Note that in the case of loose hop reoptimization of contiguous inter-domain TE LSP or local reoptimization of stitched/nested S-LSP where boundary LSRs are specified as loose hops, the TE LSP may follow a preferable path within one or more domain(s) but would still traverse the same set of boundary LSRs. In contrast, in the case of PCE-based path computation techniques, because end to end optimal path is computed, the reoptimization process may lead to following a completely different inter-domain path (including a different set of boundary LSRs).

7. IANA Considerations

This document makes no request for any IANA action.

8. Security Considerations

Signaling of inter-domain TE LSPs raises security issues (discussed in section 7 of [[I-D.ietf-ccamp-inter-domain-rsvp-te](#)]).

[RFC4726] provides an overview of the requirements for security in an MPLS-TE or GMPLS multi-domain environment. In particular, when signaling an inter-domain RSVP-TE LSP, an operator may make use of the security features already defined for RSVP-TE ([[RFC3209](#)]). This

may require some coordination between the domains to share the keys (see [[RFC2747](#)] and [[RFC3097](#)]), and care is required to ensure that the keys are changed sufficiently frequently. Note that this may involve additional synchronization, should the domain border nodes be protected with Fast Reroute ([[RFC4090](#)], since the Merge Point (MP) and Point of Local Repair (PLR) should also share the key. For an inter-domain TE LSP, especially when it traverses different administrative or trust domains, the following mechanisms SHOULD be provided to an operator (also see [[RFC4216](#)]):

- 1) A way to enforce policies and filters at the domain borders to process the incoming inter-domain TE LSP setup requests (Path messages) based on certain agreed trust and service levels/contracts between domains. Various LSP attributes such as bandwidth, priority, etc. could be part of such a contract.
- 2) A way for the operator to rate-limit LSP setup requests or error notifications from a particular domain.
- 3) A mechanism to allow policy-based outbound RSVP message processing at the domain border node, which may involve filtering or modification of certain addresses in RSVP objects and messages.

This document relates to inter-domain path computation. It must be noted that the process for establishing paths described in this document does not increase the information exchanged between ASes and preserves topology confidentiality, in compliance with [[RFC4105](#)] and [[RFC4216](#)]. That being said, the signaling of inter-domain TE LSP

according to the procedure defined in this document requires path computation on boundary nodes that may be exposed to various attacks. Thus it is RECOMMENDED to support policy decisions to reject the ERO expansion of an inter-domain TE LSP if not allowed.

9. Acknowledgements

We would like to acknowledge input and helpful comments from Adrian Farrel, Jean-Louis Le Roux, Dimitri Papadimitriou and Faisal Aslam.

10. References

10.1. Normative References

- [RFC2119] Bradner, S., "Key words for use in RFCs to Indicate Requirement Levels", [BCP 14](#), [RFC 2119](#), March 1997.
- [RFC3209] Awduche, D., Berger, L., Gan, D., Li, T., Srinivasan, V., and G. Swallow, "RSVP-TE: Extensions to RSVP for LSP Tunnels", [RFC 3209](#), December 2001.

Vasseur, et al.

Expires May 19, 2008

[Page 19]

Internet-Draft

[draft-ietf-ccamp-inter-domain-pd-06](#)

November 2007

- [RFC3473] Berger, L., "Generalized Multi-Protocol Label Switching (GMPLS) Signaling Resource ReserVation Protocol-Traffic Engineering (RSVP-TE) Extensions", [RFC 3473](#), January 2003.

10.2. Informative References

- [I-D.ietf-ccamp-crankback]
Farrel, A., "Crankback Signaling Extensions for MPLS and GMPLS RSVP-TE", [draft-ietf-ccamp-crankback-06](#) (work in progress), January 2007.
- [I-D.ietf-ccamp-inter-domain-rsvp-te]
Ayyangar, A., "Inter domain Multiprotocol Label Switching (MPLS) and Generalized MPLS (GMPLS) Traffic Engineering - RSVP-TE extensions", [draft-ietf-ccamp-inter-domain-rsvp-te-07](#) (work in progress), September 2007.
- [I-D.ietf-ccamp-lsp-stitching]

Ayyangar, A., "Label Switched Path Stitching with Generalized Multiprotocol Label Switching Traffic Engineering (GMPLS TE)", [draft-ietf-ccamp-lsp-stitching-06](#) (work in progress), April 2007.

- [RFC2702] Awduche, D., Malcolm, J., Agogbua, J., O'Dell, M., and J. McManus, "Requirements for Traffic Engineering Over MPLS", [RFC 2702](#), September 1999.
- [RFC2747] Baker, F., Lindell, B., and M. Talwar, "RSVP Cryptographic Authentication", [RFC 2747](#), January 2000.
- [RFC3097] Braden, R. and L. Zhang, "RSVP Cryptographic Authentication -- Updated Message Type Value", [RFC 3097](#), April 2001.
- [RFC3630] Katz, D., Kompella, K., and D. Yeung, "Traffic Engineering (TE) Extensions to OSPF Version 2", [RFC 3630](#), September 2003.
- [RFC3784] Smit, H. and T. Li, "Intermediate System to Intermediate System (IS-IS) Extensions for Traffic Engineering (TE)", [RFC 3784](#), June 2004.
- [RFC4090] Pan, P., Swallow, G., and A. Atlas, "Fast Reroute Extensions to RSVP-TE for LSP Tunnels", [RFC 4090](#), May 2005.
- [RFC4105] Le Roux, J., Vasseur, J., and J. Boyle, "Requirements for

Vasseur, et al.

Expires May 19, 2008

[Page 20]

Internet-Draft

[draft-ietf-ccamp-inter-domain-pd-06](#)

November 2007

Inter-Area MPLS Traffic Engineering", [RFC 4105](#), June 2005.

- [RFC4203] Kompella, K. and Y. Rekhter, "OSPF Extensions in Support of Generalized Multi-Protocol Label Switching (GMPLS)", [RFC 4203](#), October 2005.
- [RFC4205] Kompella, K. and Y. Rekhter, "Intermediate System to Intermediate System (IS-IS) Extensions in Support of Generalized Multi-Protocol Label Switching (GMPLS)", [RFC 4205](#), October 2005.
- [RFC4216] Zhang, R. and J. Vasseur, "MPLS Inter-Autonomous System

(AS) Traffic Engineering (TE) Requirements", [RFC 4216](#), November 2005.

- [RFC4655] Farrel, A., Vasseur, J., and J. Ash, "A Path Computation Element (PCE)-Based Architecture", [RFC 4655](#), August 2006.
- [RFC4726] Farrel, A., Vasseur, J., and A. Ayyangar, "A Framework for Inter-Domain Multiprotocol Label Switching Traffic Engineering", [RFC 4726](#), November 2006.
- [RFC4736] Vasseur, JP., Ikejiri, Y., and R. Zhang, "Reoptimization of Multiprotocol Label Switching (MPLS) Traffic Engineering (TE) Loosely Routed Label Switched Path (LSP)", [RFC 4736](#), November 2006.

Authors' Addresses

JP Vasseur (editor)
Cisco Systems, Inc
1414 Massachusetts Avenue
Boxborough, MA 01719
USA

Email: jpv@cisco.com

Arthi Ayyangar (editor)
Juniper Networks, Inc
1194 N.Mathilda Ave
Sunnyvale, CA 94089
USA

Email: arthi@juniper.net

Vasseur, et al.

Expires May 19, 2008

[Page 21]

Internet-Draft

[draft-ietf-ccamp-inter-domain-pd-06](#)

November 2007

Raymond Zhang
BT
2160 E. Grand Ave.
El Segundo, CA 90025
USA

Email: raymond.zhang@bt.com

Full Copyright Statement

Copyright (C) The IETF Trust (2007).

This document is subject to the rights, licenses and restrictions contained in [BCP 78](#), and except as set forth therein, the authors retain all their rights.

This document and the information contained herein are provided on an "AS IS" basis and THE CONTRIBUTOR, THE ORGANIZATION HE/SHE REPRESENTS OR IS SPONSORED BY (IF ANY), THE INTERNET SOCIETY, THE IETF TRUST AND THE INTERNET ENGINEERING TASK FORCE DISCLAIM ALL WARRANTIES, EXPRESS OR IMPLIED, INCLUDING BUT NOT LIMITED TO ANY WARRANTY THAT THE USE OF THE INFORMATION HEREIN WILL NOT INFRINGE ANY RIGHTS OR ANY IMPLIED WARRANTIES OF MERCHANTABILITY OR FITNESS FOR A PARTICULAR PURPOSE.

Intellectual Property

The IETF takes no position regarding the validity or scope of any Intellectual Property Rights or other rights that might be claimed to pertain to the implementation or use of the technology described in this document or the extent to which any license under such rights might or might not be available; nor does it represent that it has made any independent effort to identify any such rights. Information on the procedures with respect to rights in RFC documents can be found in [BCP 78](#) and [BCP 79](#).

Copies of IPR disclosures made to the IETF Secretariat and any assurances of licenses to be made available, or the result of an attempt made to obtain a general license or permission for the use of such proprietary rights by implementers or users of this specification can be obtained from the IETF on-line IPR repository at <http://www.ietf.org/ipr>.

The IETF invites any interested party to bring to its attention any copyrights, patents or patent applications, or other proprietary rights that may cover technology that may be required to implement this standard. Please address the information to the IETF at ietf-ipr@ietf.org.

Acknowledgment

Funding for the RFC Editor function is provided by the IETF Administrative Support Activity (IASA).

