

Question(s): 14/15

Geneva, 5-16 December 2011

TD**Source:** Editor G.8151/Y.1374**Title:** Draft revised Recommendation ITU-T G.8151/Y.1374 (for Consent)

The document contains the draft version of G.8151/Y.1374 Revision. It aligns the published version of the Recommendation (10/2007) with the result of the MPLS-TP work.

Version (v09) was in alignment with the management related information (i.e. the MI signals) specified in draft G.8121 (WD44r6, Beijing), draft G.8121.1 (WD46r3), and draft G.8121.2 (WD45r1).

Document history:

Version	Date	Description
00	April 30, 2009	<ul style="list-style-type: none"> ▪ Change the term T-MPLS to MPLS-TP ▪ Change the abbreviation TM to MT ▪ In tables 7-1, 8-1, 8-2, 8-3, 8-4, and 10-1 note the need to update the fault cause (cXXX), MI signals, value range, and PM primitive per G.8121
01	May 28, 2009	<ul style="list-style-type: none"> ▪ Updated per the review at the Sophia-Antipolis meeting
02	Sep. 17, 2009	TD179 (WP3/15) Geneva, 28 September - 09 October 2009 <ul style="list-style-type: none"> ▪ Update Section 3.1 Terms ▪ Update Section 7.2.1 adding pointer to G.7710 for mapping of failures to probable causes ▪ Update Section 7.2.14 Table 7-3 for the Operational State ▪ Create a place holder in Section 10.2 for MT.NE specific performance management requirements

Contact: Hing-Kam Lam
Alcatel-Lucent
USA

Tel: +1 908 582 0672
Fax: +1 908 582 1124
Email: Kam.Lam@alcatel-lucent.com

Contact: Scott Mansfield
Ericsson
USA

Tel: +1 724 931 9316
Email: scott.mansfield@ericsson.com

Attention: This is not a publication made available to the public, but an **internal ITU-T Document** intended only for use by the Member States of ITU, by ITU-T Sector Members and Associates, and their respective staff and collaborators in their ITU related work. It shall not be made available to, and used by, any other persons or entities without the prior written consent of ITU-T.

Version	Date	Description
03	April 12, 2010	WD17 (Q9, 10, 12, 14) Stockholm, 12-16 April 2010 <ul style="list-style-type: none"> Align Figure 6.4 with the generic figure of G.7710 Corrigendum 1 Also presented as TD352/3 in the June 2010 SG15 plenary meeting.
04	Nov. 2010	WD25 (Q9, 10, 12, 14) Berlin, November 15 – 19, 2010 <ul style="list-style-type: none"> To align with WD28 for MT_TT_So and MT_TT_Sk in Table 7-1 (failure), Table 7-2 (ARC), Table 7-3 (Operational state), Table 8-1 (configuration), and Table 10-1 (PM primitive) To align with WD17 for MT/MT_A_So, MT/MT_A_Sk, and MT/ETH_A_So in Table 8-2
05	Nov. 2010	WD25r1 (Q9, 10, 12, 14) Berlin, November 15 – 19, 2010 <ul style="list-style-type: none"> Restore the non-MPLS-TP server adaptation failure (Table 7-1), ARC (Table 7-2), Operation state (Table 7-3), and configuration (Table 8-1) to be consistent with G.8121.
06	Nov. 2010	WD25r2 (Q9, 10, 12, 14) Berlin, November 15 – 19, 2010 <ul style="list-style-type: none"> For MT_TT, change CV to CC to align with changes made in G.8121 (WD19r2)
07	Sept. 2011	WD11 (Q9, 10, 12, 14) Beijing, September 5 – 9, 2011 <ul style="list-style-type: none"> Align with wd07 (Beijing) for MT_TT_So I/O and MT_TT_Sk I/O Align with wd08 (Beijing) for MTDe_FT_So I/O and MTDe_FT_Sk I/O
08	Sep 6, 2011	WD11r1 (Q3, 9, 10, 12, 14) Beijing <ul style="list-style-type: none"> Align with changes in WD44r1 (G.8121) for changing “Priority” to CoS and splitting CC & CV related MI
09	Sep 8, 2011 (WD11r2, Beijing)	WD11r2 (Beijing) to align with WD44r3 (G.8121) and WD45r1 (G.8121.2) <ul style="list-style-type: none"> Create references to G.8121.1 and G.8121.2 Change “P” to “CoS” Add MI_TT_So_MI_CC_DP, value range 1,2,3, default 1 MT_TT_So/Sk: Merge CC_OAM_Tool and CV_OAM_Tool → CC_OAM_Tool, Merge CC_Enable and CV_Enable → CC_Enable, Merge CC_CoS and CV_CoS → CC_CoS Complete Table 8-1 and Table 8-3 (including align with Table 9-C1/G.8121) Change FT to TT Create text for the management of the G.8121.2 specific aspects
10	Dec. 8, 2011 (WD18 GVA)	WD18 (TD543r1/P) <ul style="list-style-type: none"> Remove default value for OAM Tools Align with changes in G.8121 (WD25r2/Q9 Dec. 2011)

ITU-T Recommendation G.8151/Y.1374 (~~G.tmpls-mgmt~~)

Management aspects of the ~~T~~-MPLS-TP network element

1	SCOPE	5
2	REFERENCES.....	6
3	DEFINITIONS	8
4	ABBREVIATIONS AND ACRONYMS.....	9
5	CONVENTIONS.....	11
6	MPLS-TP MANAGEMENT ARCHITECTURE	11
6.1	MPLS-TP NETWORK MANAGEMENT ARCHITECTURE	11
6.1.1	<i>Relationship between TMN, MT.MN and MT.MSN.....</i>	<i>11</i>
6.1.2	<i>Access to the MT.MSN.....</i>	<i>11</i>
6.1.3	<i>MT.MSN requirements.....</i>	<i>12</i>
6.1.4	<i>MT.MSN Data Communication Network.....</i>	<i>12</i>
6.1.5	<i>Management of DCN.....</i>	<i>17</i>
6.1.6	<i>Remote log-in.....</i>	<i>17</i>
6.1.7	<i>Relationship between technology domains.....</i>	<i>17</i>
6.2	MPLS-TP EQUIPMENT MANAGEMENT ARCHITECTURE.....	17
6.3	INFORMATION FLOWS OVER MANAGEMENT POINTS (MP)	19
7	FAULT (MAINTENANCE) MANAGEMENT.....	20
7.1	FAULT MANAGEMENT APPLICATIONS.....	20
7.1.1	<i>Supervision.....</i>	<i>20</i>
7.1.2	<i>Validation.....</i>	<i>20</i>
7.1.3	<i>Alarm Handling.....</i>	<i>21</i>
7.2	FAULT MANAGEMENT FUNCTIONS	22
7.2.1	<i>Fault Cause Persistency function – PRS.....</i>	<i>23</i>
7.2.2	<i>Severity Assignment function – SEV.....</i>	<i>25</i>
7.2.3	<i>Alarm Reporting Control function – ARC.....</i>	<i>25</i>
7.2.4	<i>Reportable Failure function – REP.....</i>	<i>27</i>
7.2.5	<i>Unit Alarms function – UNA.....</i>	<i>27</i>
7.2.6	<i>Network Element Alarms function – NEA.....</i>	<i>27</i>
7.2.7	<i>Station Alarms function – STA.....</i>	<i>27</i>
7.2.8	<i>TMN Event Pre-processing function – TEP.....</i>	<i>27</i>
7.2.9	<i>Alarm Synchronization function – ASY.....</i>	<i>27</i>
7.2.10	<i>Logging function – LOG.....</i>	<i>27</i>
7.2.11	<i>TMN Alarm Event Notification function – TAN.....</i>	<i>28</i>
7.2.12	<i>Current Problem List function – CPL.....</i>	<i>28</i>
7.2.13	<i>Alarm Status function – AST.....</i>	<i>28</i>
7.2.14	<i>Operational State function – OPS.....</i>	<i>28</i>
7.2.15	<i>External Events.....</i>	<i>29</i>
8	CONFIGURATION MANAGEMENT.....	29
8.1	HARDWARE.....	29

8.2	SOFTWARE	29
8.3	PROTECTION SWITCHING	29
8.4	TRAIL TERMINATION.....	29
8.5	ADAPTATION.....	34
8.6	CONNECTION.....	42
8.7	DEG THRESHOLDS.....	47
8.8	XXX_REPORTED	47
8.9	ALARM SEVERITY	47
8.10	ALARM REPORTING CONTROL (ARC)	47
8.11	PM THRESHOLDS	47
8.12	TCM ACTIVATION	47
8.13	DATE & TIME.....	47
	8.13.1 Date & Time Applications.....	47
	8.13.2 Date & Time Functions.....	48
9	ACCOUNTING MANAGEMENT.....	48
10	PERFORMANCE MANAGEMENT	48
	10.1 PERFORMANCE MANAGEMENT APPLICATIONS	48
	10.2 PERFORMANCE MONITORING FUNCTIONS	48
11	SECURITY MANAGEMENT.....	49

ITU-T Recommendation G.8151/Y.1374 (~~G.8151-1/Y.1374-1~~)

Management aspects of the ~~T~~-MPLS-TP network element

Summary

This Recommendation addresses management aspects of the ~~Transport-MPLS~~ Transport Profile (MPLS-TP) capable network element containing transport functions of one or more of the layer networks of the ~~transport-MPLS-TP~~ network. The management of the ~~transport-MPLS-TP~~ layer networks is separable from that of its client layer networks so that the same means of management can be used regardless of the client. The management functions for fault management, configuration management, performance monitoring, and security management are specified.

The 2011~~0~~ Revision of this Recommendation ~~has been aligned~~ with the MPLS-TP architecture and requirements jointly developed by IETF and ITU-T and provides the specification for managing MPLS-TP NEs that support the OAM protocol neutral equipment functionality as defined in [ITU-T G.8121/Y.1381], ~~in the 2008/2009 time frame and documented in [IETF RFC 5654 mpls tp req], [IETF RFC 5860 mpls tp oam req], and [IETF RFC 5951 mpls tp nm req].~~

Formatted: Strikethrough

Formatted: Strikethrough

Formatted: Strikethrough

1 Scope

This Recommendation addresses management aspects of the ~~Transport-MPLS~~ Transport Profile (~~T~~-MPLS-TP) capable network element containing transport functions of one or more of the layer networks of the ~~T~~-MPLS-TP network. The management of the ~~T~~-MPLS-TP layer networks is separable from that of its client layer networks so that the same means of management can be used regardless of the client. In this version of the Recommendation, fault management, configuration management, performance management, and security management are specified. Accounting management is for further study.

<Editor Note: may need to delete G.8121.1 and G.8121.2.>

Formatted: Highlight

The generic requirements for managing transport network elements are specified in [ITU-T G.7710/Y.1701] and the requirements for the management of equipment used in networks supporting an MPLS Transport Profile (MPLS-TP) are specified in [b-IETF RFC 5951]. This Recommendation specifies the requirements for managing the following MPLS-TP specific equipment functional blocks, which are defined in [ITU-T G.8121/Y.1381]; ~~[ITU-T ITU-T G.8121.1/Y.1381.1], and [ITU-T ITU-T G.8121.2/Y.1381.2].~~ Furthermore, only the management information (MI) of the following ~~T~~-MPLS-TP equipment functions are ~~is~~ addressed:

Formatted: Tab stops: 8.5 cm, Centered + cm, Right

Formatted: Highlight

- ~~T~~-MPLS-TP layer connection function,
- ~~T~~-MPLS-TP layer trail termination functions,
- ~~T~~-MPLS-TP server to ~~T~~-MPLS-TP client adaptation functions,
- ~~T~~-MPLS-TP server to Ethernet client adaptation functions,
- SDH server to ~~T~~-MPLS-TP client adaptation functions,
- PDH server to ~~T~~-MPLS-TP client adaptation functions, ~~and~~
- ~~OTN sever to T-MPLS-TP client adaptation functions, and~~
- ~~ETN server to MPLS-TP client adaptation functions.~~

The management of the adaptation of other clients and servers with respect to ~~T~~-MPLS-TP is for further study.

This Recommendation also describes the management network organizational model for communication between an element management layer (EML) Operations System and the \mathbb{T} -MPLS-TP equipment management function within an \mathbb{T} -MPLS-TP network element.

The architecture described in this Recommendation for the management of \mathbb{T} -MPLS-TP transport networks is based upon the following considerations:

- The management view of network element functional elements should be uniform whether those elements form part of an inter-domain interface or part of an intra-domain interface. Those properties necessary to form such a uniform management view are to be included in this Recommendation.
- \mathbb{T} -MPLS-TP layer network entities (\mathbb{T} M \mathbb{T} LNE) refer to trail termination, adaptation and connection functions as described in [ITU-T G.8110.1/Y.1370.1],
- a network element may only contain \mathbb{T} -MPLS-TP layer network entities,
- a network element may contain both \mathbb{T} -MPLS-TP layer network entities (\mathbb{T} M \mathbb{T} LNE) and client layer network entities (CLNE),
- client layer entities are managed as part of their own logical domain (e.g. Ethernet management network),
- CLNE and \mathbb{T} M \mathbb{T} LNE may or may not share a common message communication function (MCF) and management application function (MAF) depending on application,
- CLNE and \mathbb{T} M \mathbb{T} LNE may or may not share the same agent.

This Recommendation is compliant with the transport profile of MPLS (MPLS TP) as defined by the IETF. In the event of a misalignment in MPLS TP related architecture and protocols between this ITU-T Recommendation and the referenced IETF RFCs, the RFCs will take precedence.

This Recommendation provides a representation of the MPLS-TP technology using the methodologies that have been used for other transport technologies (e.g. SDH, OTN and Ethernet). The representation of MPLS-TP provided in this ITU-T Recommendation is not intended to modify MPLS as defined by the IETF RFCs normatively referenced by this Recommendation.

Formatted: Not Highlight

Formatted: Not Highlight

Formatted: Font: (Asian) Times New Roman English (U.K.)

2 References

The following ITU-T Recommendations and other references contain provisions, which, through reference in this text, constitute provisions of this Recommendation. At the time of publication, the editions indicated were valid. All Recommendations and other references are subject to revision; all users of this Recommendation are therefore encouraged to investigate the possibility of applying the most recent edition of the Recommendations and other references listed below. A list of the currently valid ITU-T Recommendations is regularly published. The reference to a document within this Recommendation does not give it, as a stand-alone document, the status of a Recommendation.

- | | |
|-----------------------|--|
| [ITU-T G.805] | ITU-T Recommendation G.805 (2000), <i>Generic functional architecture of transport networks</i> . |
| [ITU-T G.806] | ITU-T Recommendation G.806 (2009 6), <i>Characteristics of transport equipment – Description methodology and generic functionality</i> |
| [ITU-T G.7041/Y.1303] | ITU-T Recommendation G.7041/Y.1303 (2008 5) and Amendment 1 (2006), <i>Generic framing procedure (GFP)</i> |
| [ITU-T G.7710/Y.1701] | ITU-T Recommendation G.7710/Y.1701 (2007), <i>Common equipment management function requirements, plus Corrigendum 1 (2009)</i> |

- [ITU-T G.7712/Y.1703] ITU-T Recommendation G.7712/Y.1703 (2010~~93~~), *Architecture and specification of data communication network*
- [ITU-T G.8110.1/Y.1370.1] ITU-T Recommendation G.8110.1/Y.1370.1 (2011~~096~~), *Architecture of ~~Transport MPLS~~ Transport Profile (T-MPLS-TP) layer network*
- ~~[ITU-T G.8112/Y.1371] ITU-T Recommendation G.8112/Y.1371 (2009~~6~~), *Interfaces for the Transport MPLS Transport Profile (T-MPLS-TP) Hierarchy.*~~
- ~~[ITU-T G.8114/Y.1373] ITU-T Recommendation G.8114/Y.1373 (ex Y.17~~tom~~), (2007), *Operation & Maintenance mechanisms for T-MPLS layer networks*~~
- [ITU-T G.8121/Y.1381~~4744~~] ITU-T Recommendation G.8121/Y.1381~~4744~~ (2011~~096~~) and Amendment 1 (2007), *Characteristics of multi protocol label switched (MPLS) Transport Profile (MPLS-TP) equipment functional blocks*
- [ITU-T G.8121.1/Y.1381.1] ITU-T Recommendation G.8121.1/Y.1381.1 (2011), *Characteristics of MPLS Transport Profile (MPLS-TP) equipment functional blocks supporting G.8113.1/Y.1372.1*
- [ITU-T G.8121.2/Y.1381.2] ITU-T Recommendation G.8121.2/Y.1381.2 (2011), *Characteristics of MPLS Transport Profile (MPLS-TP) equipment functional blocks supporting G.8113.2/Y.1372.2*
- [ITU-T M.20] ITU-T Recommendation M.20 (1992), *Maintenance philosophy for telecommunication networks.*
- [ITU-T M.3010] ITU-T Recommendation M.3010 (2000) and Amendments, *Principles for a telecommunications management network*
- [ITU-T M.3013] ITU-T Recommendation M.3013 (2000), *Considerations for a telecommunications management network.*
- [ITU-T M.3100] ITU-T Recommendation M.3100 (2005), *Generic network information model.*
- [ITU-T X.700] ITU-T Recommendation X.700 (1992), *Management framework for Open Systems Interconnection (OSI) For CCITT Applications.*
- [ITU-T X.701] ITU-T Recommendation X.701 (1997), *Information technology – Open Systems Interconnection – Systems management overview.*
- [ITU-T X.733] ITU-T Recommendation X.733 (1992) and Amendments, *Information technology – Open Systems Interconnection – Systems Management: Alarm reporting function.*
- [ITU-T X.735] ITU-T Recommendation X.735 (1992) and Amendments, *Information technology – Open Systems Interconnection – Systems management: Log control function.*
- ~~[IETF RFC 5654mpls tp req] IETF RFC 5654mpls tp req (2009), *MPLS TP Requirements.*~~
- ~~[IETF RFC 5860mpls tp oam req] IETF RFC 5860mpls tp oam req (20109), *Requirements for OAM in MPLS Transport Networks.*~~
- ~~[IETF RFC 5951mpls tp nm req] IETF RFC 5951mpls tp nm req (20109), *MPLS TP Network Management Requirements.*~~

Formatted: English (U.S.)

Formatted: Ref_text

Formatted: English (U.S.)

Formatted: Indent: Before: 0 cm, First line: 0.5 cm

Formatted: Font: Not Bold

Formatted: Indent: Before: 0 cm, Hanging: 5.08 cm, Tab stops: 5.08 cm, Left

3 Definitions

3.1 Terms defined elsewhere

This Recommendation uses the following terms defined elsewhere:

~~3.1.1~~ The following terms are defined in [ITU-T G.7710/Y.1701]:

~~3.1.1~~ Local Craft Terminal: [ITU-T G.7710/Y.1701]

~~3.1.2~~ Management Application Function (MAF): [ITU-T G.7710/Y.1701]

~~3.1.2~~ The following terms are defined in [ITU-T G.7712/Y.1703]:

~~3.1.3~~ Data Communication Network (DCN): [ITU-T G.7712/Y.1703]

~~3.1.3~~ The following terms are defined in [ITU-T G.806]:

~~3.1.4~~ Atomic Function (AF): [ITU-T G.806]

~~3.1.5~~ Management Point (MP): [ITU-T G.806]

~~3.1.4~~ The following terms are defined in [ITU-T M.3010]:

~~3.1.6~~ Network Element (NE): [ITU-T M.3010]

~~3.1.7~~ Network Element Function (NEF): [ITU-T M.3010]

~~3.1.8~~ Operations System (OS): [ITU-T M.3010]

~~3.1.9~~ Q-Interface: [ITU-T M.3010]

~~3.1.10~~ Workstation Function (WF): [ITU-T M.3010]

~~3.1.5~~ The following term is defined in [ITU-T M.3013]:

~~3.1.11~~ Message Communication Function (MCF): [ITU-T M.3013]

~~3.1.6~~ The following terms are defined in [ITU-T M.3100]:

~~3.1.12~~ Alarm reporting: [ITU-T M.3100]

~~3.1.13~~ Alarm Reporting Control (ARC): [ITU-T M.3100];

~~3.1.14~~ Managed entity: [ITU-T M.3100];

~~3.1.15~~ Management interface: [ITU-T M.3100];

~~3.1.16~~ Persistence interval: [ITU-T M.3100];

~~3.1.17~~ Operations System (OS): [ITU-T M.3100];

~~3.1.18~~ Operations System Function (OSF): [ITU-T M.3100];

~~3.1.19~~ Qualified problem: [ITU-T M.3100];

~~3.1.20~~ Reset threshold report: [ITU-T M.3100];

~~3.1.21~~ Threshold report: [ITU-T M.3100];

~~3.1.22~~ Timed interval: [ITU-T M.3100];

~~3.1.7~~ The following term is defined in [ITU-T X.700]:

~~3.1.23~~ Managed Object (MO): [ITU-T X.700]

~~3.1.8~~ The following terms are defined in [ITU-T X.701]:

~~3.1.24~~ Agent: [ITU-T X.701]

~~3.1.25~~ Manager: [ITU-T X.701]

Formatted: Bullets and Numbering

Formatted: French (France)

Formatted: French (France)

Formatted: English (U.S.)

Formatted: German (Germany)

Formatted: French (France)

Formatted: English (U.S.)

Formatted: French (France)

Formatted: Bullets and Numbering

Formatted: French (France)

Formatted: Bullets and Numbering

Formatted: French (France)

Formatted: German (Germany)

Formatted: Bullets and Numbering

Formatted: Bullets and Numbering

3.1.26 Managed Object Class (MOC): [ITU-T X.701]

3.2 Terms defined in this Recommendation

This Recommendation defines or specializes the following terms:

3.2.1 \mathbb{T} -MPLS-TP Management Network (\mathbb{FMT} .MN): An \mathbb{T} -MPLS-TP Management Network is a subset of a TMN that is responsible for managing those parts of a network element that contain \mathbb{T} -MPLS-TP layer network entities. A \mathbb{FMT} .MN may be subdivided into a set of \mathbb{T} -MPLS-TP Management SubNetworks.

3.2.2 \mathbb{T} -MPLS-TP Management SubNetwork (\mathbb{FMT} .MSN): An \mathbb{T} -MPLS-TP Management SubNetwork (\mathbb{FMT} .MSN) consists of a set of separate Embedded Control Channels (ECC) and associated intra-site data communication links which are interconnected to form a Data Communications Network (DCN) within any given \mathbb{T} -MPLS-TP transport topology. For \mathbb{T} -MPLS-TP, the physical channel supporting the ECC is the \mathbb{T} -MPLS-TP Management Communication Channel (MCC) as defined in [ITU-T G.81447712/Y.170373]. A \mathbb{FMT} .MSN represents a \mathbb{T} -MPLS-TP specific Local Communication Network (LCN) portion of a network operator's overall Data Communication Network or TMN.

3.2.3 \mathbb{T} -MPLS-TP Network Element (\mathbb{FMT} .NE): That part of a network element that contains entities from one or more \mathbb{T} -MPLS-TP layer networks. A \mathbb{FMT} .NE may therefore be a standalone physical entity or a subset of a network element. It supports at least Network Element Functions (NEF) and may also support an Operations System Function (OSF). It contains Managed Objects (MO), a Message Communication Function (MCF) and a Management Application Function (MAF). The functions of a \mathbb{FMT} .NE may be contained within an NE that also supports other layer networks. These layer network entities are considered to be managed separately from \mathbb{T} -MPLS-TP entities. As such they are not part of the \mathbb{FMT} .MN or \mathbb{FMT} .MSN.

4 Abbreviations and acronyms

This Recommendation uses the following abbreviations:

AcSL	Accepted Signal Label
AF	Atomic Function
AIS	Alarm Indication Signal
ALM	ALarM reporting
ARC	Alarm Reporting Control
CLNE	Client Layer Network Entity
CP	Connection Point
CtrlP	Control Plane
DCN	Data Communication Network
ECC	Embedded Communication Channel
EMF	Equipment Management Function
FCAPS	Fault Management, Configuration Management, Account Management, Performance Management and Security Management
FFS	For Further Study
GNE	Gateway Network Element

IP	Internet Protocol
ITU-T	International Telecommunication Union – Telecommunication Standardization Sector
LAN	Local Area Network
LCN	Local Communication Network
LCT	Local Craft Terminal
MAF	Management Application Function
MCC	Management Communication Channel
MCF	Message Communication Function
MD	Mediation Device
MF	Mediation Function
MI	Management Information
MIB	Management Information Base
MN	Management Network
MO	Managed Object
MOC	Managed Object Class
MP	Management Point
MgmtP	Management Plane
MPLS	Multi-Protocol Label Switching
TP -MPLS-TP	Transport -MPLS Transport Profile
MSN	Management SubNetwork
TP MT.C	TP -MPLS-TP Channel layer
TP MT.MN	TP -MPLS-TP MN
TP MT.MSN	TP -MPLS-TP MSN
TP MT.NE	TP -MPLS-TP NE
TP MT.P	TP -MPLS-TP Path layer
TP MT.S	TP -MPLS-TP Section layer
TP MTM-n	TP -MPLS-TP Transport Module layer n
NALM	No ALARm reporting
NALM-CD	No ALARm reporting, Count Down
NALM-NR	No ALARm reporting, Not Ready
NALM-QI	No ALARm reporting, Qualified Inhibit
NALM-TI	No ALARm reporting, Timed Inhibit
NE	Network Element
NEF	Network Element Function

Formatted: English (U.S.)

Formatted: English (U.S.)

Comment [KL1]: Need confirmation on the name of the channel layer.

Formatted: English (U.S.), Not Highlight

Formatted: English (U.S.)

NEL	Network Element Layer
OAM	Operations, Administration, Maintenance
OAM&P	Operations, Administration, Maintenance and Provisioning
OS	Operations System
OSF	Operations System Function
OSI	Open Systems Interconnection
PMC	Performance Monitoring Clock
QoS	Quality of Service
SCC	Signalling Communication Channel
RTC	Real Time Clock
TCM	Tandem Connection Monitoring
TMN	Telecommunication Management Network
WAN	Wide Area Network
WS	WorkStation
WTR	Wait To Restore

5 Conventions

In this Recommendation, \mathbb{F} MT.MN stands for \mathbb{F} -MPLS-TP Management Network, \mathbb{F} MT.MSN for \mathbb{F} -MPLS-TP Management Subnetwork, \mathbb{F} MT.NE for \mathbb{F} -MPLS-TP NE, \mathbb{F} MT.C for \mathbb{F} -MPLS-TP Channel layer, \mathbb{F} MT.P for \mathbb{F} -MPLS-TP Path layer, and \mathbb{F} MT.S for \mathbb{F} -MPLS-TP Section layer.

6 \mathbb{F} -MPLS-TP management architecture

See [ITU-T G.7710] section 6 for the generic architecture for managing transport equipment. \mathbb{F} -MPLS-TP specific management architecture is described below.

6.1 \mathbb{F} -MPLS-TP network management architecture

The transport layer networks architecture of ~~Transport MPLS (T-MPLS-TP)~~ are described in [ITU-T G.8110.1/Y.1370.1], ~~and [ITU-T G.8112/Y.1371], and [ITU-T G.8114/Y.1373].~~ The management of the \mathbb{F} -MPLS-TP layer networks is separable from that of its client layer networks so that the same means of management can be used regardless of the client.

6.1.1 Relationship between TMN, \mathbb{F} MT.MN and \mathbb{F} MT.MSN

The \mathbb{F} -MPLS-TP Management Network (\mathbb{F} MT.MN) may be partitioned into \mathbb{F} -MPLS-TP Management SubNetworks (\mathbb{F} MT.MSNs). The inter-relationship between a management network, its subnetworks and a TMN as generically described in section 6 of [ITU-T G.7710/Y.1701] is applicable to \mathbb{F} -MPLS-TP.

6.1.2 Access to the \mathbb{F} MT.MSN

See [ITU-T G.7710/Y.1701] section 6.1.2 for the generic requirements.

6.1.3 FMT.MSN requirements

See [ITU-T G.7710/Y.1701] section 6.1.3 for the generic requirements.

In addition all FMT.NEs must support Message Communication Functions (MCFs). The MCF of an FMT.NE initiates/terminates (in the sense of the lower protocol layers), forwards, or otherwise processes management messages over MCCs, or over other DCN interfaces. In addition:

- All FMT.NEs are required to terminate the FMT.S-MCCs, ~~see 6.1.8~~. In OSI terms, this means that each NE must be able to perform the functions of an end system.
- FMT.NEs may also be required to forward management messages between ports according to routing control information held in the FMT.NE. In OSI terms, this means that some FMT.NEs may be required to perform the functions of an intermediate system.
- In addition to supporting interfaces for the FMT.S-MCC, a FMT.NE may also be required to support other DCN interfaces, which may include FMT.P-MCCs or FMT.C-MCCs or an Ethernet DCN interface.

The use of the FMT.P-MCCs and FMT.C-MCCs for management communications is within the scope of this Recommendation, ~~see 6.1.7~~.

6.1.4 FMT.MSN Data Communication Network

Refer to [ITU-T G.7710/Y.1701] section 6.1.4 for the generic requirements.

6.1.4.1 Management Communication Channel

The FMT.MN supports three Management Communication Channels (MCCs):

- 1) FMT.S-MCC (MCC_S)
- 2) FMT.P-MCC (MCC_P)
- 3) FMT.C-MCC (MCC_C)

The general FMT.S-, FMT.P-, and FMT.C-MCCs are ~~defined~~ described in [ITU-T G.7712/Y.1703 G.8114/Y.1373].

Figure 6-1 illustrates a network scenario consisting of two operators. Operator B provides an FMT.P Service to operator A (i.e. Operator B transports the FMT.P signal that begins and ends Operator A's domain). According to ~~Amendment 1 of~~ [ITU-T G.8110.1/Y.1370.1], the MCC_P and the MCC_C signals passed transparently through Operator B's network.

Formatted: Not Highlight

Formatted: Not Highlight

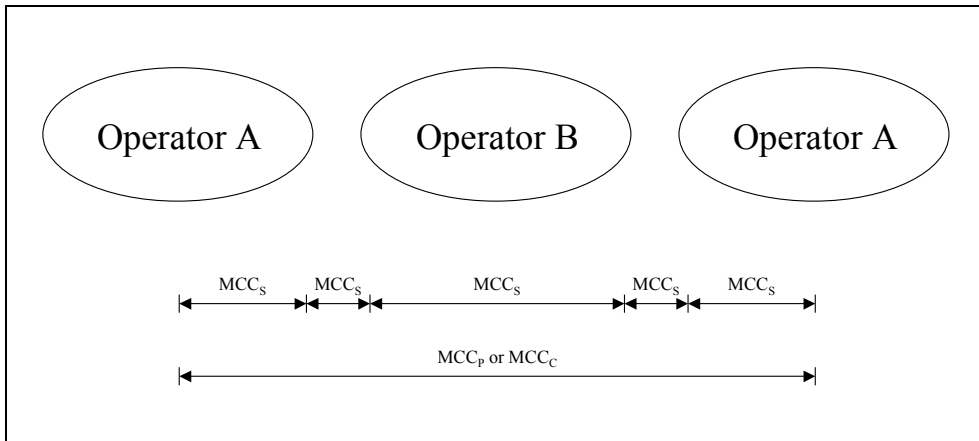

Figure 6-1/G.8151/Y.1374 – MCC scenarios

The physical layer is terminated in every network element and its related adaptation function provides the FMT_S signals as well as the MCC_S . Hence, the MCC_S cannot cross administrative domains. In Figure 6-1, Figure 6-2, and Figure 6-3 illustrate scenarios where the MCC_P and MCC_C are transported transparently through Operator B's domain (the Operator B network elements are not shown in Figure 6-2 and Figure 6-3). In these scenarios it is possible that Operator B may use the MCC_S within its own domain for the management of its domain.

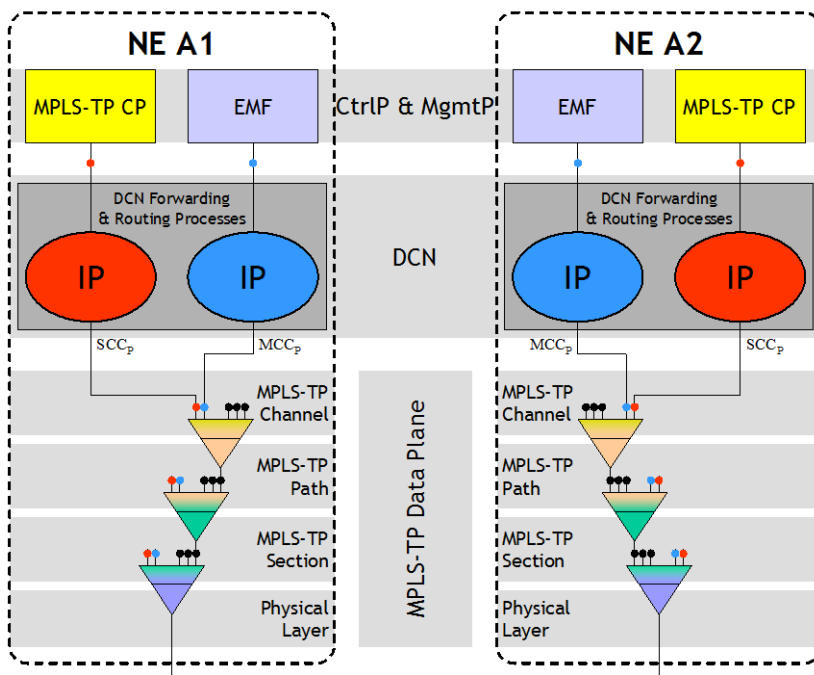
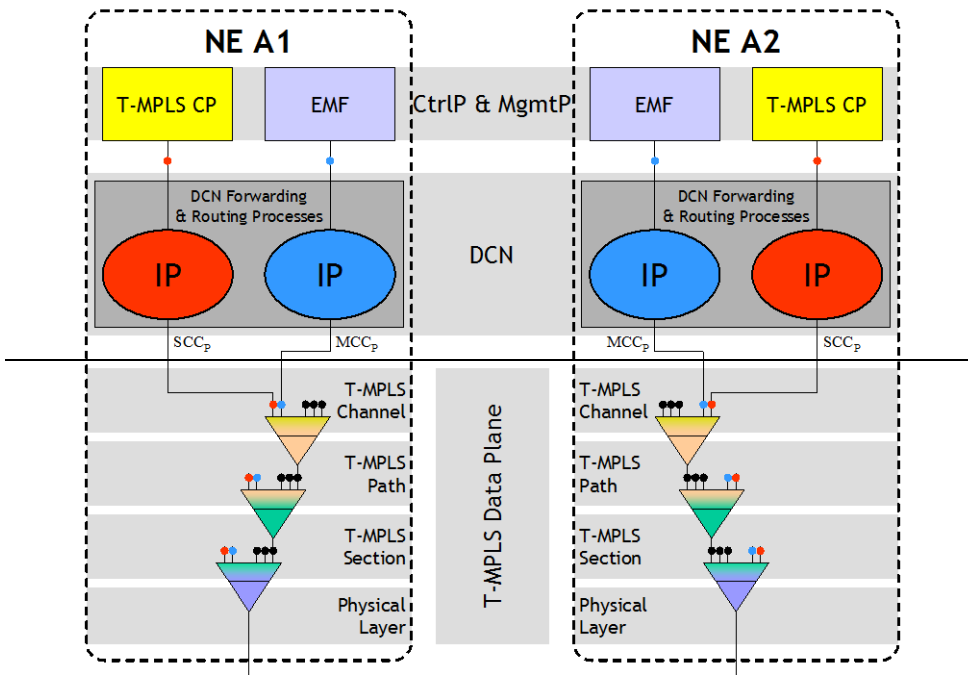
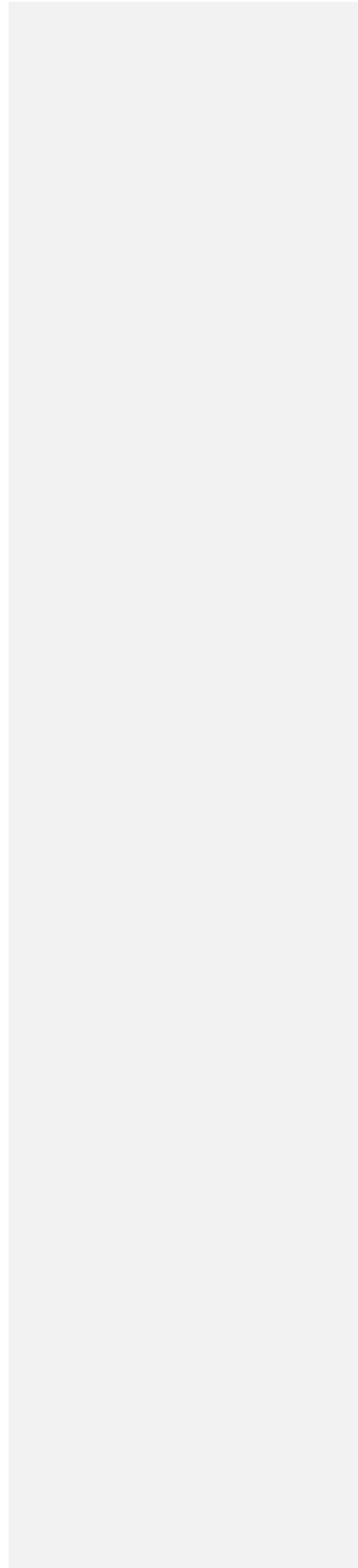

Figure 6-2/G.8151/Y.1374 – MCC_p Scenario Example 1



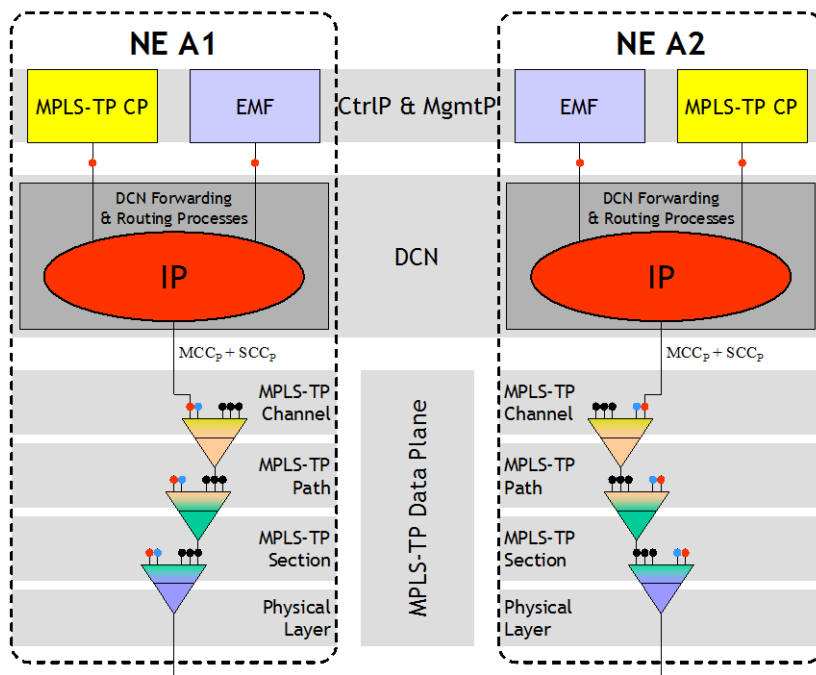
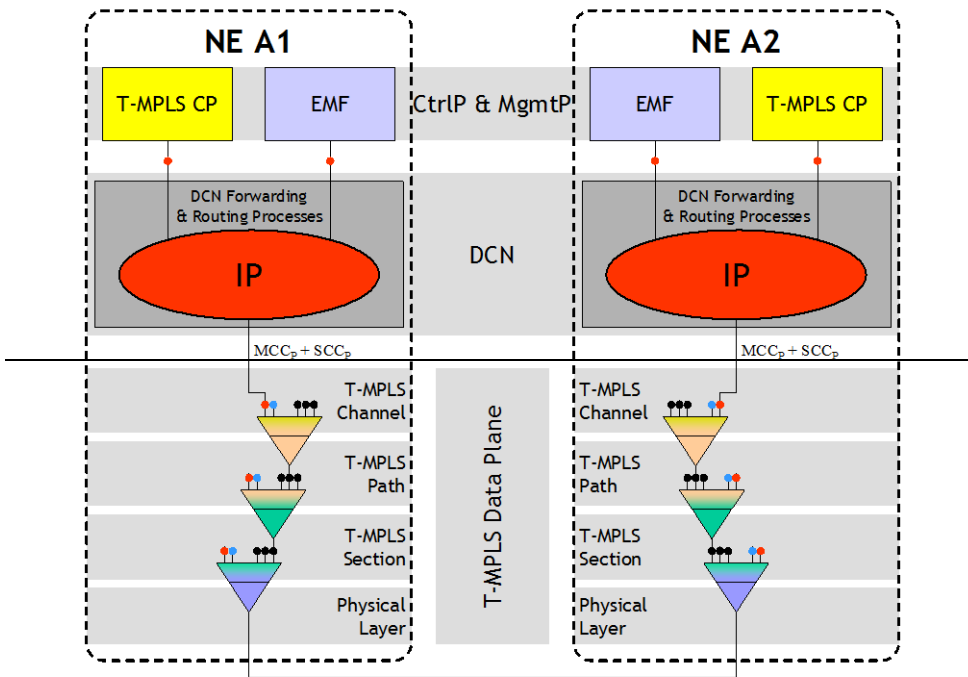

Figure 6-3/G.8151/Y.1374 – MCC_P Scenario Example 2

6.1.4.2 MCC physical characteristics

The \mathbb{F} MT_S-, \mathbb{F} MT_C- and \mathbb{F} MT_P-MCCs are logical elements within the \mathbb{F} -MPLS-TP Transport Module (\mathbb{F} MTM-n). The MCC provides general management communications between two \mathbb{F} -MPLS-TP network elements with access to the \mathbb{F} MT_S, \mathbb{F} MT_P, and \mathbb{F} MT_C characteristic information respectively. The \mathbb{F} MT_S-, \mathbb{F} MT_P-, or \mathbb{F} MT_C-MCC is provided by the \mathbb{F} -MPLS-TP OAM function at section, path, or channel layer as ~~defined~~ described in [ITU-T G.7712/Y.1703 G.8114/Y.1373] or by any other ECC of the \mathbb{F} -MPLS-TP transport network ~~that is under study for [ITU-T G.7712/Y.1703]~~.

The \mathbb{F} MT_S Management Communication Channel (MCC_S) shall operate as a single message channel between \mathbb{F} MT_S termination points. The bit rate of the MCC_S shall be configurable. ~~Further details are under study for [ITU-T G.7712/Y.1703]~~.

The \mathbb{F} MT_P Management Communication Channel (MCC_P) shall operate as a single message channel between any network elements that terminate the \mathbb{F} MT_P layer. The MCC_P is transported transparently through \mathbb{F} MT_{NE}s that only terminate the \mathbb{F} MT_S layer and forward the \mathbb{F} MT_P signal. The bit rate of the MCC_P shall be configurable. ~~Further details are under study for [ITU-T G.7712/Y.1703]~~.

The \mathbb{F} MT_C Management Communication Channel (MCC_C) shall operate as a single message channel between any network elements that terminate the \mathbb{F} MT_C layer. The MCC_C is transported transparently through \mathbb{F} MT_{NE}s that only terminate the \mathbb{F} MT_S layer or the \mathbb{F} MT_S and \mathbb{F} MT_P layers and forward the \mathbb{F} MT_C signal. The bit rate of the MCC_C shall be configurable. ~~Further details are under study for [ITU-T G.7712/Y.1703]~~.

6.1.4.3 MCC data link layer protocol

The MCC data link protocols for management applications are under study for [ITU-T G.7712/Y.1703].

6.1.5 Management of DCN

See [ITU-T G.7710/Y.1701] section 6.1.5 for the generic requirements.

6.1.6 Remote log-in

See [ITU-T G.7710/Y.1701] section 6.1.6 for the generic requirements.

6.1.7 Relationship between technology domains

See [ITU-T G.7710/Y.1701] section 6.1.7 for the generic requirements.

6.2 \mathbb{F} -MPLS-TP equipment management architecture

This section provides an overview of the minimum functions which are required to support inter-vendor/network communications and single-ended maintenance of \mathbb{F} MT_{NE}s within an MSN, or between communicating peer \mathbb{F} MT_{NE}s across a network interface. Single-ended maintenance is the ability to access remotely located \mathbb{F} MT_{NE}s to perform maintenance functions (see the Performance Management Applications, section 14.0.1 of [ITU-T G.7710/Y.1701]).

It should be noted that the management functions have been categorized according to the classifications given in [ITU-T X.700].

Detailed specifications of the management functions, in terms of managed objects classes, attributes and message specification, are for further study.

The \mathbb{T} -MPLS-TP Equipment Management Function (EMF) (see Figure 6-4) provides the means through which the \mathbb{T} -MPLS-TP Network Element Function (NEF) is managed by an internal or external manager. If a Network Element (NE) contains an internal manager, this manager will be part of the \mathbb{T} -MPLS-TP EMF.

The \mathbb{T} -MPLS-TP EMF interacts with the other atomic functions (refer to [ITU-T G.8121/Y.138741]) by exchanging information across the MP reference points. See [ITU-T G.806] and [ITU-T G.8121/Y.17441381] for more information on Atomic Functions and on MPs. The \mathbb{T} -MPLS-TP EMF contains a number of functions that provide a data reduction mechanism on the information received across the MP reference points. The outputs of these functions are available to the agent via the network element resources and Management Application Functions (MAF) which represent this information as managed objects.

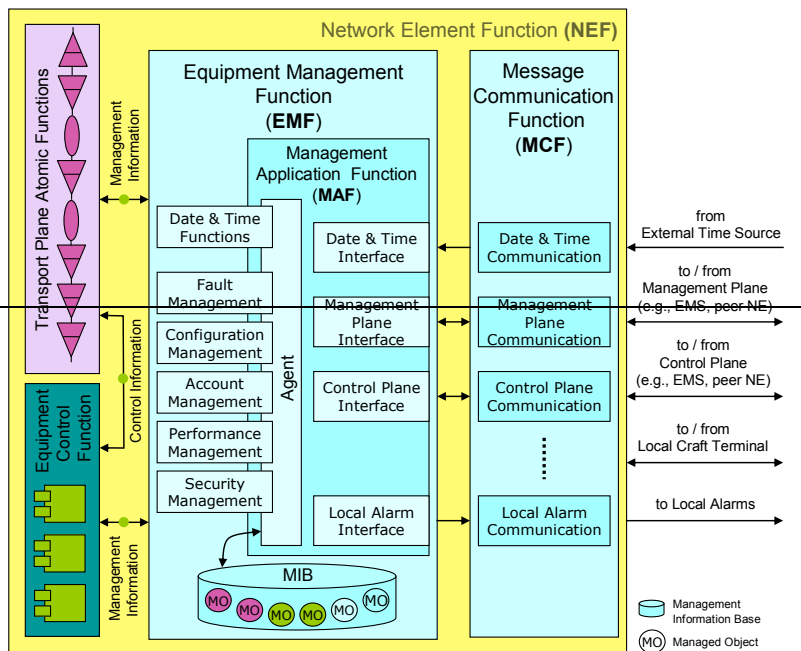

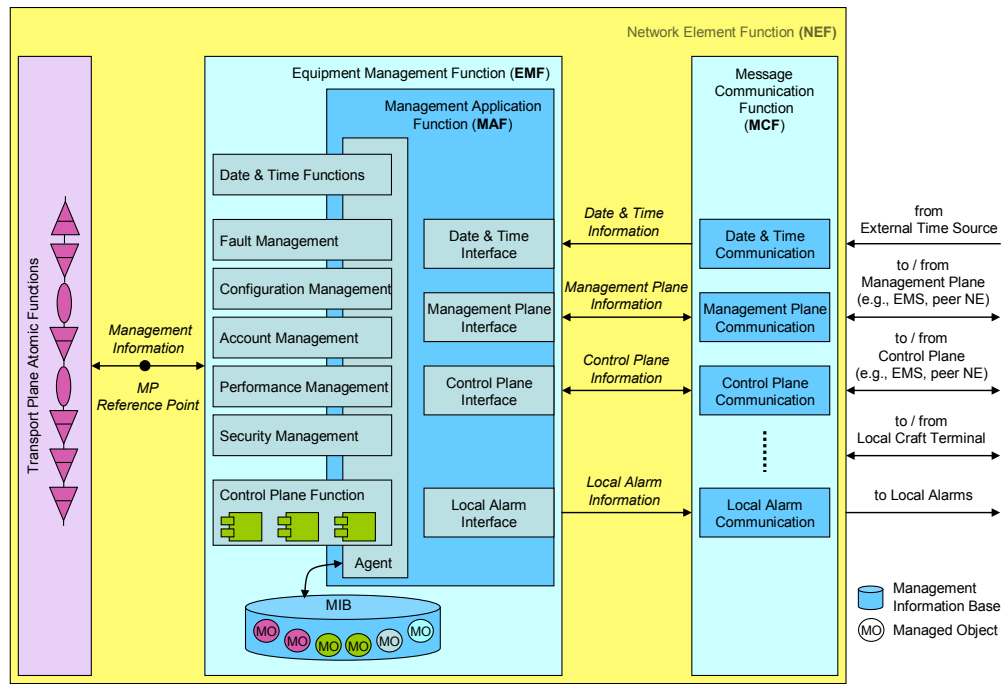

Figure 6.4/G.8151/Y.1374 — T-MPLS-TP Equipment Management Function

Network element resources provide event processing and storage. The MAF processes the information provided to and by the NE resources. The agent converts this information to management messages and responds to management messages from the manager by performing the appropriate operations on the managed objects.

This information to and from the agent is passed across the V reference point to the Message Communication Function (MCF).

6.3 Information flows over Management Points (MP)

The information flows described in this clause are functional. The existence of these information flows in the equipment will depend on the functionality provided by the T-MPLS-TP NE and the options selected.

The information flow over the MP reference points that arises from anomalies and defects detected in the atomic functions is described in specific details for each atomic function in [ITU-T G.8121/Y.1381+741].

The information flow over the MP reference points that arises from configuration and provisioning and reporting data is described in specific details for each atomic function in [ITU-T G.8121/Y.1381+741]. The information listed under the Set-Input column refers to the configuration and provisioning data that is passed from the T-MPLS-TP EMF to the atomic functions. The information listed under the Get-Output column refers to the status-reports passed to made in response to a request from the T-MPLS-TP EMF for such information from the atomic functions.

7 Fault (maintenance) Management

Fault Management is a set of functions which enables the detection, isolation and correction of abnormal operation of the telecommunication network and its environment. It provides facilities for the performance of the maintenance phases from [ITU-T M.20]. The quality assurance measurements for fault management include component measurements for reliability, availability and survivability.

7.1 Fault Management Applications

See [ITU-T G.7710/Y.1701] for a description of the basic Fault Management applications.

7.1.1 Supervision

The supervision process describes the way in which the actual occurrence of a disturbance or fault is analyzed with the purpose of providing an appropriate indication of performance and/or detected fault condition to maintenance personnel. The supervision philosophy is based on the concepts underlying the functional model of [ITU-T G.805], [ITU-T G.8110.1/Y.1370.1], and the Alarm Reporting Function of [ITU-T X.733].

The five basic supervision categories are related to transmission, quality of service, processing, equipment, and environment. These supervision processes are able to declare fault causes, which need further validation before the appropriate alarm is reported. See [ITU-T G.7710/Y.1701] for additional discussion of these categories.

The ~~MT~~NE shall indicate to the OS when a Termination Point is no longer able to supervise the signal (e.g. implementing equipment has a fault or loss of power).

7.1.1.1 Transmission Supervision

See clause 7.1.1.1 of [ITU-T G.7710/Y.1701] for a description of transmission supervision.

For MT,NE, the following defects that must be monitored for the purpose of transmission supervision are defined in clause 6.1/G.8121.

~~< To be provided per G.8121 >~~

The atomic function associated failure conditions are listed in clause 7.2.1.

Formatted: Bullets and Numbering

Formatted: English (U.K.)

7.1.1.2 Quality of Service Supervision

See [ITU-T G.7710/Y.1701] for a description of quality of service supervision.

7.1.1.3 Processing Supervision

See [ITU-T G.7710/Y.1701] for a description of processing supervision.

7.1.1.4 Hardware Supervision

See [ITU-T G.7710/Y.1701] for a description of equipment supervision.

7.1.1.5 Environment Supervision

See [ITU-T G.7710/Y.1701] for a description of environmental supervision.

7.1.2 Validation

See [ITU-T G.7710/Y.1701] for a description of fault cause validation.

7.1.3 Alarm Handling

7.1.3.1 Severity Assignment

See [ITU-T G.7710/Y.1701] for a description of severity categories.

7.1.3.2 Alarm Reporting Control

Alarm Reporting Control (ARC) provides an automatic in-service provisioning capability.

The following ARC states may be specified for a managed entity:

ALM	ALArM reporting; Alarm reporting is turned on.
NALM	No ALArM reporting; Alarm reporting is turned off.
NALM-CD	No ALArM reporting, Countdown; This is a substate of NALM-QI and performs the persistence timing countdown function when the managed entity is qualified problem free.
NALM-NR	No ALArM reporting, NotReady; This is a substate of NALM-QI and performs a wait function until the managed entity is qualified problem free.
NALM-QI	No ALArM reporting, Qualified Inhibit; Alarm reporting is turned off until the managed entity is qualified problem free for a specified persistence interval.
NALM-TI	No ALArM reporting, Timed Inhibit; Alarm Reporting is turned off for a specified timed interval.

Alarm reporting may be turned off (using NALM, NALM-TI, or NALM-QI) on a per-managed entity basis to allow sufficient time for customer testing and other maintenance activities in an "alarm free" state. Once a managed entity is ready, alarm reporting is automatically turned on (to ALM). The managed entity may be automatically turned on either by using NALM-TI or NALM-QI and allowing the resource to transition out automatically, or by invoking first the NALM state from an EMS and when maintenance activity is done, invoking the ALM state. This later automation is carried out by the EMS. For further details relating to ARC, see [ITU-T M.3100].

7.1.3.3 Reportable Failures

See [ITU-T G.7710/Y.1701] for a description of reportable failures.

7.1.3.4 Alarm Reporting

Alarm surveillance is concerned with the detection and reporting of relevant events and conditions which occur in the network. In a network, events and conditions detected within the equipment and incoming signals should be reportable. In addition, a number of events external to the equipment should also be reportable. Alarms are indications that are automatically generated by an NE as a result of the declaration of a failure. The OS shall have the ability to define which events and conditions generate autonomous reports, and which shall be reported on request.

The following alarm-related functions shall be supported:

1. Autonomous reporting of alarms;
2. Request for reporting of all alarms;
3. Reporting of all alarms;
4. Allow or inhibit of autonomous alarm reporting;
5. Reporting on request status of allow or inhibit alarm reporting;

6. Reporting of protection switch events.

7.1.3.4.1 Local Reporting

See [ITU-T G.7710/Y.1701] for a description of local reporting.

7.1.3.4.2 TMN Reporting

See [ITU-T G.7710/Y.1701] for a description of TMN reporting.

7.2 Fault Management functions

Figure 7-1 contains the functional model of Fault Management inside the ~~T~~-MPLS-TP EMF. This model is consistent with the alarm flow functional model, specified in [ITU-T M.3100]. It must be noted that it does not address configuration aspects relating to Fault Management, the full ARC functional model, nor does it define where all possible event report parameters get assigned. Figure 7-1 is intended only to illustrate which well-known functions are impacted by ARC, and which are not, and to provide a generalized alarm flow view.

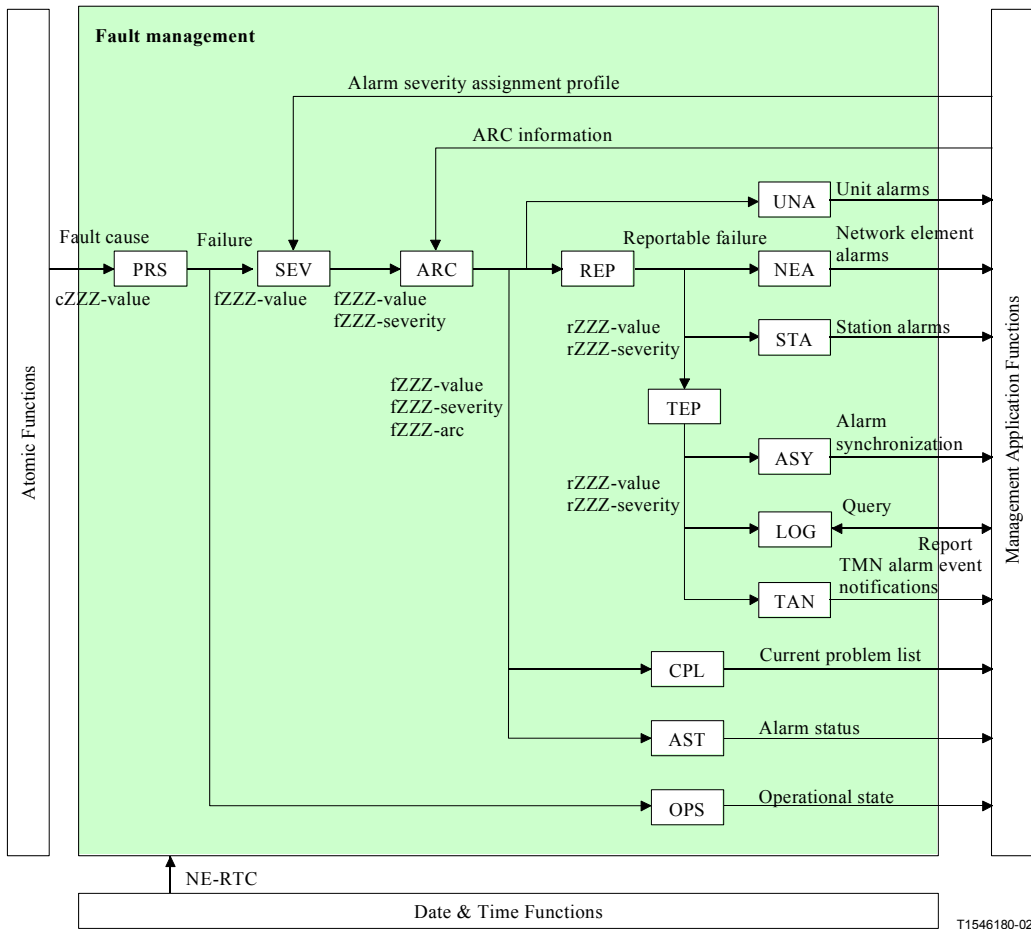

Figure 7-1/G.8151/Y.1374– Fault management within the T-MPLS-TP NEF

7.2.1 Fault Cause Persistency function – PRS

The defect correlations provide a data reduction mechanism on the fault and performance monitoring primitives' information presented at the MP reference points.

The equipment management function within the network element performs a persistency check on the fault causes (that are reported across the MP reference points) before it declares a fault cause a failure. In addition to the transmission failures, hardware failures with signal transfer interruption are also reported at the input of the fault cause function for further processing. See Figure 7-2.

Symbol

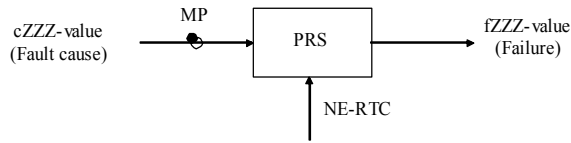

Figure 7-2/G.8151/Y.1374– Fault Cause Persistency function

For MT.NE that supports the following functions specified in [ITU-T G.8121/Y.1381], the EMF PRS process shall support the persistency check for the fault causes listed in Table 7-1.

Inputs and outputs

Table 7-1/G.8151/Y.1374– Inputs/outputs for the fault cause persistency function

<u>Process-Atomic Function</u> (G.8121)	<u>Input</u>	<u>Output</u>
FMT ₂ _TT_Sk	cSSF cLCK cLOC _h cMMG cUNI cUNM cUNP-CC cUNP-CV cUNC-CC cUNC-CV _P cUNPhb cDEG cRDI	fSSF fLCK fLOC _h fMMG fUNI fUNM fUNP-CC fUNP-CV fUNC-CC _P fUNC-CV fUNPhb fDEG fRDI
Sn/FMT_A_Sk	cPLM cLFD cEXM cUPM	fPLM fLFD fEXM fUPM
Sn-X-L/FMT_A_Sk	cPLM cLFD cEXM cUPM	fPLM fLFD fEXM fUPM
Sm/FMT_A_Sk	cPLM cLFD cEXM cUPM	fPLM fLFD fEXM fUPM
Sm-X-L/FMT_A_Sk	cPLM cLFD cEXM cUPM	fPLM fLFD fEXM fUPM

Formatted Table

Formatted Table

Process-Atomic Function (G.8121)	Input	Output
Pq/FMT_A_Sk	cPLM cLFD cEXM cUPM	fPLM fLFD fEXM fUPM
Pq-X-L/FMT_A_Sk	cPLM cLFD cEXM cUPM	fPLM fLFD fEXM fUPM
ODUKP/FMT_A_Sk	cPLM cLFD cEXM cUPM	fPLM fLFD fEXM fUPM
ODUKP-X-L/FMT_A_Sk	cVcPLM cLFD cEXM cUPM	fVcPLM fLFD fEXM fUPM

Formatted: English (U.K.)

See [ITU-T G.7710] for the mapping of failure (fXXX) to the generic probable cause to be used in alarm reporting.

Process

The equipment management function within the network element performs a persistency check on the fault causes before it declares a fault cause a failure.

A transmission failure (fXXX) shall be declared if the fault cause persists continuously for 2.5 ± 0.5 s. The failure shall be cleared if the fault cause is absent continuously for 10 ± 0.5 s.

The specific set of failures associated with each atomic function is listed in Table 7-1.

The failure declaration and clearing shall be time stamped. The time-stamp shall indicate the time at which the fault cause is activated at the input of the fault cause persistency (i.e. defect-to-failure integration) function, and the time at which the fault cause is deactivated at the input of the fault cause persistency function.

7.2.2 Severity Assignment function – SEV

See [ITU-T G.7710/Y.1701] for a description of the severity assignment function.

7.2.3 Alarm Reporting Control function – ARC

The Alarm Report Control (ARC) function allows a Management System to control the alarm reporting on a managed entity basis as defined in [ITU-T M.3100].

The alarms that can be controlled with this function are defined for each atomic function in [ITU-T G.8121/Y.1381+744].

The following ARC states may be specified for a managed entity:

ALM ALarM reporting; Alarm reporting is turned on.

NALM No ALarM reporting; Alarm reporting is turned off.

- NALM-CD No ALarM reporting, Countdown; This is a substate of NALM-QI and performs the persistence timing countdown function when the managed entity is qualified problem free.
- NALM-NR No ALarM reporting, NotReady; This is a substate of NALM-QI and performs a wait function until the managed entity is qualified problem free.
- NALM-QI No ALarM reporting, Qualified Inhibit; Alarm reporting is turned off until the managed entity is qualified problem free for a specified persistence interval.
- NALM-TI No ALarM reporting, Timed Inhibit; Alarm Reporting is turned off for a specified timed interval.

The ALM state is required for all managed entities that can detect alarms.

In addition at least one of the states: NALM, NALM-TI, or NALM-QI must be supported.

If NALM-QI is supported, then NALM-NR is required and NALM-CD is optional.

For MT.NE that supports the following functions specified in [ITU-T G.8121/Y.1381], the EMF ARC process shall support the ARC function for the failures listed in Table 7-2.

Table 7-2/G.8151/Y.1374– ARC specifications for ~~F~~-MPLS-TP

Atomic Function	Qualified Problems	QoS Reporting	Default State Value
F MT 2 _TT_Sk	f SSE f LCK f LOCH f MMG f UNL f UNM f UNP-CC f UNP-CV f UNC-CC Phb f UNC-CV f DEG f RDI FFS	FFS	FFS ALM
Sn/ F MT_A_Sk	f PLM f LFD f EXM f UPM FFS	FFS	ALM FFS
Sn-X-L/ F MT_A_Sk	f PLM f LFD f EXM f UPM FFS	FFS	ALM FFS
Sm/ F MT_A_Sk	f PLM f LFD f EXM f UPM FFS	FFS	ALM FFS
Sm-X-L/ F MT_A_Sk	f PLM f LFD f EXM	FFS	ALM FFS

Formatted Table

Formatted: English (U.S.), Not Highlight

Formatted: English (U.S.), Not Highlight

Formatted: English (U.S.), Not Highlight

Formatted: English (U.S.), Not Highlight

Formatted: English (U.S.), Not Highlight

Formatted: English (U.S.), Not Highlight

Formatted: Font: 11 pt, Complex Script Font, 11 pt, Not Highlight

Formatted: Font: 11 pt, Complex Script Font, 11 pt, Not Highlight

Atomic Function	Qualified Problems	QoS Reporting	Default State Value
	<u>fUPM</u> FFS		
Pq/ FMT _A_Sk	<u>fPLM</u> <u>fLFD</u> <u>fEXM</u> <u>fUPM</u> FFS	FFS	<u>ALM</u> FFS
Pq-X-L/ FMT _A_Sk	<u>fPLM</u> <u>fLFD</u> <u>fEXM</u> <u>fUPM</u> FFS	FFS	<u>ALM</u> FFS
ODUkP/ FMT _A_Sk	<u>fPLM</u> <u>fLFD</u> <u>fEXM</u> <u>fUPM</u> FFS	FFS	<u>ALM</u> FFS
ODUkP-X-L/ FMT _A_Sk	<u>fVcPLM</u> <u>fLFD</u> <u>fEXM</u> <u>fUPM</u> FFS	FFS	<u>ALM</u> FFS

7.2.4 Reportable Failure function – REP

See [ITU-T G.7710/Y.1701] for a description of the reportable failure function.

7.2.5 Unit Alarms function – UNA

See [ITU-T G.7710/Y.1701] for a description of the unit alarms function.

7.2.6 Network Element Alarms function – NEA

See [ITU-T G.7710/Y.1701] for a description of the network element alarms function.

7.2.7 Station Alarms function – STA

See [ITU-T G.7710/Y.1701] for a description of the station alarms function.

7.2.8 TMN Event Pre-processing function – TEP

See [ITU-T G.7710/Y.1701] for a description of the TMN event pre-processing function.

7.2.9 Alarm Synchronization function – ASY

See [ITU-T G.7710/Y.1701] for a description of the alarm synchronization function.

7.2.10 Logging function – LOG

Alarm history management is concerned with the recording of alarms. Historical data shall be stored in registers in the NE. Each register contains all the parameters of an alarm message.

Registers shall be readable on demand or periodically. The OS can define the operating mode of the registers as wrapping or stop when full. The OS may also flush the registers or stop recording at any time.

NOTE – Wrapping is the deletion of the earliest record to allow a new record when a register is full. Flushing is the removal of all records in the register. See [ITU-T X.735] for additional details.

See [ITU-T G.7710/Y.1701] for a description of the logging function.

7.2.11 TMN Alarm Event Notification function – TAN

See [ITU-T G.7710/Y.1701] for a description of the TMN alarm event notification function.

7.2.12 Current Problem List function – CPL

See [ITU-T G.7710/Y.1701] for a description of the current problem list function

7.2.13 Alarm Status function – AST

See [ITU-T G.7710/Y.1701] for a description of the alarm status function

7.2.14 Operational State function – OPS

See [ITU-T G.7710/Y.1701] for a description of the operational state function.

For MT,NE that supports the following functions specified in [ITU-T G.8121/Y.1381], the EMF OPS process shall support the failures listed in Table 7-2, which ~~The following table~~ lists the failures that could influence the operational state of the related objects.

Table 7-3/G.8151/Y.1374– Operational State Function Input and Output Signals for MPLS-TP

<u>Atomic Function</u>	<u>Failure input (fZZZ-value)</u>	<u>Operational State output (Enabled/Disabled)</u>
<u>MT,TT,Sk</u>	<u>fSSF</u>	<u>Enabled</u>
	<u>fLCK</u>	<u>Enabled</u>
	<u>fLOCH</u>	<u>Enabled</u>
	<u>fMMG</u>	<u>Enabled</u>
	<u>fUNI</u>	<u>Enabled</u>
	<u>fUNM</u>	<u>Enabled</u>
	<u>fUNP-CC</u>	<u>Enabled</u>
	<u>fUNP-CV</u>	<u>Enabled</u>
	<u>fUNC-CC</u>	<u>Enabled</u>
	<u>fUNC-CV</u>	<u>Enabled</u>
	<u>fDEG</u>	<u>Enabled</u>
<u>fRDI</u>	<u>Enabled</u>	
<u>Sn,MT,A,Sk</u>	<u>fPLM</u>	<u>Enabled</u>
	<u>fLFD</u>	<u>Enabled</u>
	<u>fEXM</u>	<u>Enabled</u>
	<u>fUPM</u>	<u>Enabled</u>
<u>Sn-X-L,MT,A,Sk</u>	<u>fPLM</u>	<u>Enabled</u>
	<u>fLFD</u>	<u>Enabled</u>
	<u>fEXM</u>	<u>Enabled</u>
	<u>fUPM</u>	<u>Enabled</u>
<u>Sm,MT,A,Sk</u>	<u>fPLM</u>	<u>Enabled</u>
	<u>fLFD</u>	<u>Enabled</u>
	<u>fEXM</u>	<u>Enabled</u>
	<u>fUPM</u>	<u>Enabled</u>
<u>Sm-X-L,MT,A,Sk</u>	<u>fPLM</u>	<u>Enabled</u>
	<u>fLFD</u>	<u>Enabled</u>
	<u>fEXM</u>	<u>Enabled</u>
	<u>fUPM</u>	<u>Enabled</u>

Formatted: Table_Head, Level 1

Formatted Table

Formatted: Font: 11 pt, Complex Script Font, 11 pt

Formatted: Space Before: 0 pt, After: 0 pt

Formatted: Font: 11 pt, Complex Script Font, 11 pt

Formatted: Font: 11 pt, Complex Script Font, 11 pt

Formatted: Font: 11 pt, Complex Script Font, 11 pt

Formatted: Font: 11 pt, Complex Script Font, 11 pt

Formatted: English (U.S.), Not Highlight

<u>Pq/MT_A_Sk</u>	<u>fPLM</u> <u>fLFD</u> <u>fEXM</u> <u>fUPM</u>	<u>Enabled</u> <u>Enabled</u> <u>Enabled</u> <u>Enabled</u>
<u>Pq-X-L/MT_A_Sk</u>	<u>fPLM</u> <u>fLFD</u> <u>fEXM</u> <u>fUPM</u>	<u>Enabled</u> <u>Enabled</u> <u>Enabled</u> <u>Enabled</u>
<u>ODUkP/MT_A_Sk</u>	<u>fPLM</u> <u>fLFD</u> <u>fEXM</u> <u>fUPM</u>	<u>Enabled</u> <u>Enabled</u> <u>Enabled</u> <u>Enabled</u>
<u>ODUkP-X-L/MT_A_Sk</u>	<u>fVcPLM</u> <u>fLFD</u> <u>fEXM</u> <u>fUPM</u>	<u>Enabled</u> <u>Enabled</u> <u>Enabled</u> <u>Enabled</u>

Formatted: English (U.S.)

7.2.15 External Events

For further study

8 Configuration management

See [ITU-T G.7710/Y.1701] for the generic requirements for configuration management. ~~For MPLS-TP~~ specific specifications, if needed, are explicitly described.

8.1 Hardware

See [ITU-T G.7710/Y.1701] for a description of hardware management.

8.2 Software

See [ITU-T G.7710/Y.1701] for a description of software management.

8.3 Protection Switching

See [ITU-T G.7710/Y.1701] for a description of the generic management requirements for protection switching. The MPLS-TP specific management requirements will be provided after the protection switching process is defined in G.8121.

~~For further study~~

8.4 Trail Termination

See [ITU-T G.7710/Y.1701] for a description of trail termination management.

This function allows a user to provision and monitor the operation of the ~~For MPLS-TP~~ Trail Termination process.

The MI signals listed in the ~~following table(s) of this subclause~~ are communicated between the EMF and the ~~For MPLS-TP~~ Trail Termination process across the management point within the ~~For MT~~.NE.

For MT.NE that supports the MT TT function specified in [ITU-T G.8121/Y.1381], the EMF shall support the following management functions for the MI listed in Table 8-1:

- Provisioning the trail termination management information
- Retrieving the trail termination management information
- Notifying the changes of the trail termination management information
- Receiving the monitored trail termination management information

Table 8-1/G.8151/Y.1374 – Provisioning and reporting for termination functions

<u>MI Signal</u>	<u>Value Range</u>	<u>Default Value</u>
<u>MT TT So Provisioning</u>		
<u>MT TT So MI GAL Enable</u>	<u>true, false</u>	<u>false</u>
<u>MT TT So MI TTLVALUE</u>	<u>0..255</u>	<u>255</u>
<u>MT TT So MI MEG ID</u>	<u>IP-based: To be provided</u> <u>ICC-based: 153 byte string</u> <u>String: values are OAM</u> <u>protocol-specific</u>	<u>Note-12</u>
<u>MT TT So MI MEP ID</u>	<u>String: values are OAM</u> <u>protocol-specific</u> <u>IP-based: To</u> <u>be provided</u> <u>ICC-based: 163 bytebit</u> <u>integer string</u>	<u>Note-12</u>
<u>MT TT So MI CC OAM Tool</u>	<u>G.8113.1, G.8113.2</u>	<u>G.8113.2N/A</u>
<u>MT TT So MI RDI OAM Tool</u>	<u>G.8113.1, G.8113.2</u>	<u>G.8113.2N/A</u>
<u>MT TT So MI CC Enable</u>	<u>true, false</u>	<u>false</u>
<u>MT TT So MI CC PriorityCoS</u>	<u>0, 1, 2, 3, 4, 5, 6, 7</u> <u>Note 1</u>	<u>--</u> <u>Note 17</u>
<u>MT TT So MI CC DP</u>	<u>1, 2, 3; where 1 corresponds</u> <u>to the lowest drop precedence</u>	<u>1</u>
<u>MT TT So MI CC Period</u>	<u>3.33 msec, 10 msec, 100</u> <u>msec, 1sec, 10 sec, 1 min, 10</u> <u>min</u>	<u>100 msec</u>
<u>MT TT So MI CV OAM Tool</u>		
<u>MT TT So MI CV Enable</u>	<u>true, false</u>	<u>False</u>
<u>MT TT So MI CV CoS</u>	<u>Note 1</u>	<u>Note 1</u>
<u>MT TT So MI CV Period</u>	<u>3.33 msec, 10 msec, 100</u> <u>msec, 1sec, 10 sec, 1 min, 10</u> <u>min</u>	<u>1sec</u>
<u>MT TT So MI LMp OAM Tool</u>	<u>G.8113.1, G.8113.2</u>	<u>G.8113.2 N/A</u>
<u>MT TT So MI LMp Enable[1... M_{LMp}]</u>	<u>true, false</u>	<u>false</u>
<u>MT TT So MI LMp Period[1... M_{LMp}]</u>	<u>100ms, 1s, 10s</u>	<u>100ms</u>
<u>MT TT So MI LMp PriorityCoS[1... M_{LMp}]</u>	<u>0, 1, 2, 3, 4, 5, 6, 7</u>	<u>--</u>
<u>MT TT So MI DMp OAM Tool</u>	<u>G.8113.1, G.8113.2</u>	<u>N/AG.8113.2</u>
<u>MT TT So MI DMp Enable[1... M_{DMp}]</u>	<u>true, false</u>	<u>false</u>

Formatted: German (Germany)

Formatted: German (Germany)

Formatted: Not Highlight

Formatted: English (U.S.)

Formatted: English (U.S.)

Formatted: English (U.S.)

Formatted: German (Germany)

Formatted: German (Germany)

Formatted: French (France)

Formatted: German (Germany)

Formatted: German (Germany)

Formatted: German (Germany)

Formatted: German (Germany)

<u>MI Signal</u>	<u>Value Range</u>	<u>Default Value</u>
<u>MT TT So MI DMp Period[1... M_{DMp}]</u>	<u>100ms, 1s, 10s</u>	<u>100ms</u>
<u>MT TT So MI DMp Test ID[1... M_{DMp}]</u>	<u>-- (Note 2)</u>	<u>--</u>
<u>MT TT So MI DMp PriorityCoS[1... M_{DMp}]</u>	<u>0, 1, 2, 3, 4, 5, 6, 7</u>	<u>--</u>
<u>MT TT So MI DMp Length[1... M_{DMp}]</u>	<u>Non-negative integer representing number of bytes for the length of the padding TLV.</u>	<u>0</u>
<u>MT TT So MI 1DMp OAM Tool</u>	<u>G.8113.1, G.8113.2</u>	<u>N/AG-8113.2</u>
<u>MT TT So MI 1DMp Enable[1... M_{1DMp}]</u>	<u>true, false</u>	<u>false</u>
<u>MT TT So MI 1DMp Period[1... M_{1DMp}]</u>	<u>100ms, 1s, 10s</u>	<u>100ms</u>
<u>MT TT So MI 1DMp Test ID[1... M_{1DMp}]</u>	<u>-- (Note 2)</u>	<u>--</u>
<u>MT TT So MI 1DMp PriorityCoS[1... M_{1DMp}]</u>	<u>0, 1, 2, 3, 4, 5, 6, 7</u>	<u>--</u>
<u>MT TT So MI 1DMp Length[1... M_{1DMp}]</u>	<u>Non-negative integer representing number of bytes for the length of the padding TLV.</u>	<u>0</u>
<u>MT TT So MI SLp OAM Tool</u>	<u>G.8113.1, G.8113.2</u>	<u>N/AG-8113.2</u>
<u>MT TT So MI SLp Enable[1... M_{SLp}]</u>	<u>true, false</u>	<u>false</u>
<u>MT TT So MI SLp Period[1... M_{SLp}]</u>	<u>100ms, 1s, 10s</u>	<u>100ms</u>
<u>MT TT So MI SLp Test ID[1... M_{SLp}]</u>	<u>-- (Note 2)</u>	<u>--</u>
<u>MT TT So MI SLp PriorityCoS[1... M_{SLp}]</u>	<u>0, 1, 2, 3, 4, 5, 6, 7</u>	<u>--</u>
<u>MT TT So MI SLp Length[1... M_{SLp}]</u>	<u>Non-negative integer representing number of bytes for the length of the padding TLV.</u>	<u>0</u>
<u>MT TT Sk Provisioning</u>		
<u>MT TT Sk MI MEG ID</u>	<u>String: values are OAM protocol-specificIP-based: To be provided ICC-based: 153 byte string</u>	<u>Note-2</u>
<u>MT TT Sk MI CC PeerMEP ID[]</u>	<u>String: values are OAM protocol-specificIP-based: To be provided ICC-based: List of 163 bit stringsintegers</u>	<u>Empty list</u>
<u>MT TT Sk MI CC OAM Tool</u>	<u>G.8113.1, G.8113.2</u>	<u>N/AG-8113.2</u>
<u>MT TT Sk MI RDI OAM Tool</u>	<u>G.8113.1, G.8113.2</u>	<u>N/AG-8113.2</u>
<u>MT TT Sk MI CC Enable</u>	<u>true, false</u>	<u>false</u>
<u>MT TT Sk MI CC Period</u>	<u>3,33 msec, 10 msec, 100 msec, 1sec, 10 sec, 1 min, 10 min</u>	<u>100 msec</u>
<u>MT TT Sk MI CC PriorityCoS</u>	<u>0, 1, 2, 3, 4, 5, 6, 7Note 4</u>	<u>--Note-74</u>

Formatted: German (Germany)

Formatted: German (Germany)

Formatted: German (Germany)

Formatted: German (Germany)

Formatted: German (Germany)

Formatted: German (Germany)

Formatted: German (Germany)

Formatted: German (Germany)

Formatted: German (Germany)

Formatted: German (Germany)

Formatted: German (Germany)

Formatted: German (Germany)

Formatted: German (Germany)

Formatted: German (Germany)

Formatted: German (Germany)

Formatted: German (Germany)

Formatted: German (Germany)

Formatted: German (Germany)

Formatted: German (Germany)

Formatted: German (Germany)

Formatted: German (Germany)

Formatted: Highlight

Formatted: German (Germany)

Formatted: German (Germany)

Formatted: German (Germany)

Formatted: German (Germany)

Formatted: German (Germany)

Formatted: German (Germany)

Formatted: German (Germany)

Formatted: French (France)

Formatted: German (Germany)

Formatted: German (Germany)

<u>MI Signal</u>	<u>Value Range</u>	<u>Default Value</u>
<u>MT TT Sk MI CV OAM Tool</u>		
<u>MT TT Sk MI CV Enable</u>	<u>true, false</u>	<u>false</u>
<u>MT TT Sk MI CV Period</u>	<u>3.33 msec, 10 msec, 100 msec, 1sec, 10 sec, 1 min, 10 min</u>	<u>1 sec</u>
<u>MT TT Sk MI CV CoS</u>	<u>Note 1</u>	<u>Note 1</u>
<u>MT TT Sk MI Get SvdCC</u>	<u>Last received CC frame(s) that caused defect</u>	<u>--</u>
<u>MT TT Sk MI LMp OAM Tool</u>	<u>G.8113.1, G.8113.2</u>	<u>N/AG.8113.2</u>
<u>MT TT Sk MI LMp Enable[1... M_{LMp}]</u>	<u>true, false</u>	<u>false</u>
<u>MT TT Sk MI LMp CoS[1... M_{LMp}]</u>	<u>0, 1, 2, 3, 4, 5, 6, 7</u>	<u>--</u>
<u>MT TT Sk MI LM DEGM</u>	<u>2-10; See Table 7-1/G.806</u>	<u>10</u>
<u>MT TT Sk MI LM M</u>	<u>2-10</u>	<u>10</u>
<u>MT TT Sk MI LM DEGTHR</u>	<u>0% .. 100%; See Table 7-1/G.806</u>	<u>30%</u>
<u>MT TT Sk MI LM TFMIN</u>	<u>FFS</u>	<u>FFS</u>
<u>MT TT Sk MI 1second</u>	<u>--</u>	<u>--</u>
<u>MT TT Sk MI DMp OAM Tool</u>	<u>G.8113.1, G.8113.2</u>	<u>N/AG.8113.2</u>
<u>MT TT Sk MI DMp Enable[1... M_{DMp}]</u>	<u>true, false</u>	<u>false</u>
<u>MT TT Sk MI DMp CoS[1... M_{DMp}]</u>	<u>0, 1, 2, 3, 4, 5, 6, 7</u>	<u>--</u>
<u>MT TT Sk MI 1DMp OAM Tool</u>	<u>G.8113.1, G.8113.2</u>	<u>N/AG.8113.2</u>
<u>MT TT Sk MI 1DMp Enable[1... M_{1DMp}]</u>	<u>true, false</u>	<u>false</u>
<u>MT TT Sk MI 1DMp Test ID[1... M_{1DMp}]</u>	<u>-- (Note 2)</u>	<u>--</u>
<u>MT TT Sk MI SLp OAM Tool</u>	<u>G.8113.1, G.8113.2</u>	<u>N/AG.8113.2</u>
<u>MT TT Sk MI SLp Enable[1... M_{SLp}]</u>	<u>true, false</u>	<u>false</u>
<u>MT TT Sk MI SLp CoS[1... M_{SLp}]</u>	<u>0, 1, 2, 3, 4, 5, 6, 7</u>	<u>--</u>
<u>MT TT Sk MI AIS OAM Tool</u>	<u>G.8113.1, G.8113.2</u>	<u>N/AG.8113.2</u>
<u>MT TT Sk MI LCK OAM Tool</u>	<u>G.8113.1, G.8113.2</u>	<u>N/AG.8113.2</u>
<u>MT TT Sk MI LMp Enable[1... M_{LMp}]</u>	<u>true, false</u>	<u>false</u>
<u>MT TT Sk MI DMp Enable[1... M_{DMp}]</u>	<u>true, false</u>	<u>false</u>
<u>MT TT Sk MI SLp Enable[1... M_{SLp}]</u>	<u>true, false</u>	<u>false</u>
<u>MT TT Sk MI SSF Reported</u>	<u>true, false</u>	<u>false</u>
<u>MT TT Sk MI RDI Reported</u>	<u>true, false</u>	<u>false</u>
<u>MT TT Sk Reporting</u>		
<u>MT TT Sk MI SvdCC</u>	<u>Last received CC packet(s) that causes the defect</u>	<u>--</u>

Formatted: German (Germany)

Formatted: German (Germany)

Formatted: German (Germany)

Formatted: German (Germany)

Formatted: French (France)

Formatted: German (Germany)

Formatted: German (Germany)

Formatted: German (Germany)

Formatted: Subscript

Formatted: Table_Text, Tab stops: 3.72 cm Centered

Formatted: Font color: Black, Italian (Italy), Highlight

Formatted: German (Germany)

Formatted: German (Germany)

Formatted: German (Germany)

Formatted: German (Germany)

Formatted: German (Germany)

Formatted: German (Germany)

Formatted: German (Germany)

Formatted: German (Germany)

Formatted: German (Germany)

Formatted: Subscript

Formatted: German (Germany)

Formatted: German (Germany)

Formatted: German (Germany)

Formatted: Subscript

Formatted: Table_Text, Tab stops: 3.72 cm Centered

Formatted: Font: (Asian) MS Mincho, Font color: Black, (Asian) Japanese, (Other) Italian (Italy)

Formatted: German (Germany)

Formatted: German (Germany)

Formatted: German (Germany)

Formatted: German (Germany)

Formatted: German (Germany)

Formatted: Table_head

Formatted: Table_text

<u>MI Signal</u>	<u>Value Range</u>	<u>Default Value</u>
<u>MT TT So Provisioning</u>		

Table 8-1.2/G.8151/Y.1374 – Provisioning and reporting for termination functions

<u>MI Signal</u>	<u>Value Range</u>	<u>Default Value</u>
<u>MT_TT_So Provisioning</u>		
<u>MT_TT_So_MI_CCCV_Model</u>	Coord, Sre, Sink	Coord
<u>MT_TT_So_MI_Local_MEPID</u>	See cc-ev-rdi	Note-1
<u>MT_TT_So_MI_Local_Diser</u>	32-bit value	0
<u>MT_TT_So_MI_CCCV_CoS</u>	0, 1, 2, 3, 4, 5, 6, 7	–
<u>MT_TT_Sk Provisioning</u>		
<u>MT_TT_Sk_MI_CCCV_Enable</u>	true, false	false
<u>MT_TT_Sk_MI_CCCV_Model</u>	Coord, Sre, Sink	Coord
<u>MT_TT_Sk_MI_Local_MEPID</u>	See cc-ev-rdi	Note-1
<u>MT_TT_Sk_MI_Remote_Diser</u>	32-bit value	0
<u>MT_TT_Sk_MI_CCCV_CoS</u>	0, 1, 2, 3, 4, 5, 6, 7	–
<u>MT_TT_Sk_MI_Local_Diser</u>	32-bit value	0

- Formatted: German (Germany)
- Formatted: German (Germany)
- Formatted: English (U.S.), Not Highlight
- Formatted: Not Highlight
- Formatted: Highlight
- Formatted: German (Germany)
- Formatted: German (Germany), Highlight
- Formatted: German (Germany)

Note 12: A value must be provided at provisioning

8.5 Adaptation

See section 8.5 of [ITU-T G.7710/Y.1701] for a description of adaptation management.

An Access Point that has multiple adaptation functions connected to it, thereby allowing different clients to be transported via the server signal, requires a mechanism for the selection of the active client.

This function allows a user to provision and monitor the operation of the T-MPLS-TP Adaptation processes.

The MI signals listed in the following table are communicated between the EMF and the Adaptation processes across the management point within the T-MPLS-TP NE.

For MT.NE that supports the adaptation functions specified in [ITU-T G.8121/Y.1381], the EMF shall support the following management functions for the MI listed in Table 8-2 below:

- Provisioning the flow forwarding management information
- Retrieving the flow forwarding management information
- Notifying the changes of the flow forwarding management information

Formatted: Bulleted + Level: 1 + Aligned at 0.63 cm + Tab after: 1.27 cm + Indent at: 1 cm

Table 8-2/G.8151/Y.1374 – Provisioning and reporting for adaptation functions

<u>MI Signal</u>	<u>Value Range</u>	<u>Default Value</u>
<u>MT/MT_A_So Provisioning</u>		
<u>MT/MT_A_So_MI_Admin_State</u> <u>TMT/TMT_A_So_MI</u> <u>_SCCType</u> (See Table 6-3 of G.7041)	<u>LCK, Normal</u> 0..255	<u>Normal</u> 32
<u>TMT/TMT_A_So_MI_Label</u> [1..M]	16 to (2**20)-1	– <u>Note-2</u>
<u>TMT/TMT_A_So_MI_LSPT</u> type[1..M]	E-LSP, L-LSP	<u>Note-1</u> –
<u>TMT/TMT_A_So_MI_PSEC</u> oS[1..M]	Note-1	Note-1

- Formatted: English (U.S.)
- Formatted Table
- Formatted Table
- Formatted: German (Germany)
- Formatted: German (Germany)
- Formatted: German (Germany)
- Formatted: German (Germany)

MI Signal	Value Range	Default Value
FMT/FMT_A_So_MI_PHB2EXPM Mapping[1...M]	Note-1	Note-1
FMT/FMT_A_So_MI_QoS EncodingMode[1...M]	A, B	Note-2 –
MT/MT_A_So_MI_Client_MEL [1...M]	0..7	7
MT/MT_A_So_MI_LCK_Period [1...M]	1 s, 1 min	1 s
MT/MT_A_So_MI_LCK_PSCoS [1...M]	0..7	7
MT/MT_A_So_MI_GAL_Enable [1...M]	true, false	false
MT/MT_A_Sk Provisioning		
MT/MT_A_Sk_MI_Admin_State FMT/FMT_A_Sk_MI_SCCT Type	LCK, Normal 0..255	Normal 32
FMT/FMT_A_Sk_MI_Label [1...M]	16 to (2**20)-1	Note-2 –
FMT/FMT_A_Sk_MI_LSPT Type[1...M]	E-LSP, L-LSP	Note-1 –
FMT/FMT_A_Sk_MI_PSCoS [1...M]	Note-1	Note-1
FMT/FMT_A_Sk_MI_EXPTC2PHB Mapping[1...M]	Note-1	Note-1
FMT/FMT_A_Sk_MI_QoS DecodingMode[1...M]	A, B	Note-2 –
MT/MT_A_Sk_MI_Client_MEL [1...M]	0..7	7
MT/MT_A_Sk_MI_AIS_Period [1...M]	1 s, 1 min	1 s
MT/MT_A_Sk_MI_AIS_PSCoS [1...M]	0..7	7
MT/MT_A_Sk_MI_LCK_Period [1...M]	1 s, 1 min	1 s
MT/MT_A_Sk_MI_LCK_PSCoS [1...M]	0..7	7
MT/MT_A_Sk_MI_GAL_Enable [1...M]	true, false	false
MTDi/MT_A_Sk Provisioning		
MTDi/MT_A_Sk_MI_DS_MP_Type	MEP, MIP	=
MT/ETH_A_So Provisioning		
MT/ETH_A_So_MI_Admin_State	LCK, Normal	Normal
FMT/ETH_A_So_MI_FCSEnable	true, false	true
FMT/ETH_A_So_MI_CHEnable CWEnable	true, false	false true
FMT/ETH_A_So_MI_SQUse	true, false	false
FMT/ETH_A_So_MI_PRI2PSC Mapping	Note-1	Note-1
MT/ETH_A_So_MI_MEP_MAC*	6 byte Unicast MAC address	=
MT/ETH_A_So_MI_Client_MEL*	0..7	7
MT/ETH_A_So_MI_LCK_Period*	1 s, 1 min	1 s
MT/ETH_A_So_MI_LCK_PriCoS*	0..7	7
MT/ETH_A_So_MI_MEL*	0..7	7
MT/ETH_A_Sk Provisioning		
FMT/ETH_A_Sk_MI_FCSEnable	true, false	true
FMT/ETH_A_Sk_MI_CHEnable	true, false	false
FMT/ETH_A_Sk_MI_SQCheck	true, false	false
FMT/ETH_A_Sk_MI_QoS TransitMode	X (DiffSer enabled), Y (DiffSer disabled)	–Y

Formatted: English (U.S.)

Formatted Table

Formatted: German (Germany)

Formatted: German (Germany)

Formatted: English (U.S.)

Formatted Table

Formatted: English (U.S.)

Formatted: German (Germany)

Formatted: German (Germany)

Formatted: German (Germany)

Formatted: German (Germany)

Formatted: German (Germany)

Formatted: German (Germany)

Formatted: German (Germany)

Formatted: German (Germany)

Formatted: German (Germany)

Formatted: German (Germany)

Formatted: German (Germany)

Formatted: English (U.S.)

Formatted: Not Highlight

Formatted: Not Highlight

Formatted Table

Formatted: German (Germany)

Formatted: German (Germany)

Formatted Table

Formatted: German (Germany)

MI Signal	Value Range	Default Value
F MT/ETH_A_Sk_MI_PSCCoS2PRIMapping	Note-1	Note-1
MT/ETH_A_Sk_MI_Admin_State	LCK, Normal	Normal
MT/ETH_A_Sk_MI_LCK_Period *	1 s, 1 min	1 s
MT/ETH_A_Sk_MI_LCK_CoS *	0..7	7
MT/ETH_A_Sk_MI_Client_MEL *	0..7	7
MT/ETH_A_Sk_MI_MEP_MAC *	6 byte Unicast MAC address	--
MT/ETH_A_Sk_MI_AIS_CoS *	0..7	7
MT/ETH_A_Sk_MI_AIS_Period *	1 s, 1 min	1 s
<u>MT/SCC_A_So Provisioning</u>		
MT/SCC_A_So_MI_Active	true, false	true
MT/SCC_A_So_MI_ECC_CoS	0..7	7
MT/SCC_A_So_MI_GAL_Enable	true, false	false
<u>MT/SCC_A_Sk Provisioning</u>		
MT/SCC_A_Sk_MI_Active	true, false	true
MT/SCC_A_Sk_GAL_Enable	true, false	false
<u>MT/MCC_A_So Provisioning</u>		
MT/MCC_A_So_MI_Active	true, false	true
MT/MCC_A_So_MI_ECC_CoS	0..7	7
MT/MCC_A_So_MI_GAL_enable	true, false	false
<u>MT/MCC_A_Sk Provisioning</u>		
MT/MCC_A_Sk_MI_Active	true, false	true
MT/SCC_A_Sk_GAL_Enable	true, false	false
<u>Sn/MT_A_So Provisioning</u>		
Sn/ F MT_A_So_MI_SCCType	0..255	32
Sn/ F MT_A_So_MI_Label[1...M]	16 to (2**20)-1	Note-2--
Sn/ F MT_A_So_MI_LSPTType[1...M]	E-LSP, L-LSP	Note 1 --
Sn/ F MT_A_So_MI_PSCCoS[1...M]	Note 10..7	Note 1 --
Sn/ F MT_A_So_PHB2TCEXPMapping[1...M]	Note-1	Note 1 --
Sn/ F MT_A_So_MI_QoSEncodingMode[1...M]	A, B	Note 1 --
<u>Sn/MT_A_Sk Provisioning</u>		
Sn/ F MT_A_Sk_MI_SCCType	0..255	32
Sn/ F MT_A_Sk_MI_Label[1...M]	16 to (2**20)-1	--Note-2
Sn/ F MT_A_Sk_MI_LSPTType[1...M]	E-LSP, L-LSP	--Note-1
Sn/ F MT_A_Sk_MI_PSCCoS[1...M]	Note-1	Note-1
Sn/ F MT_A_Sk_MI_EXPTC2PHBMapping[1...M]	Note-1	Note-1
Sn/ F MT_A_Sk_MI_QoSDecodingMode[1...M]	A, B	Note-1--
Sn/MT_A_Sk_MI_LCK_Period[1...M]	1 s, 1 min	1 s
Sn/MT_A_Sk_MI_LCK_CoS[1...M]	0..7	--

Formatted: English (U.S.)

Formatted Table

Formatted: German (Germany)

Formatted: German (Germany)

Formatted: German (Germany)

Formatted: German (Germany)

Formatted: English (U.K.)

Formatted: English (U.S.)

Formatted Table

Formatted: German (Germany)

Formatted: English (U.S.)

Formatted Table

Formatted: German (Germany)

Formatted: German (Germany)

Formatted: German (Germany)

Formatted: German (Germany)

Formatted: Not Highlight

MI Signal	Value Range	Default Value
Sn/MT_A_Sk_MI_Admin_State	LCK, Normal	Normal
Sn/MT_A_Sk_MI_AIS_Period[1...M]	1 s, 1 min	1 s
Sn/MT_A_Sk_MI_AIS_CoS[1...M]	0..7	--
Sn/MT_A_Sk_MI_GAL_enable[1...M]	true, false	false
<u>Sn/MT_A_Sk Reporting</u>		
Sn/FMT_A_Sk_MI_AcSL (see Table 9-11 of G.707)	0..255	--
Sn/FMT_A_Sk_MI_AcEXI (see Table 6-2 of G.7041)	0..15	--
Sn/FMT_A_Sk_MI_LastValidUPI (see Table 6-3 of G.7041)	0..255	--
<u>Sn-X-L/MT_A_So Provisioning</u>		
Sn-X-L/FMT_A_So_MI_SCCType (See Table 6-3 of G.7041)	0..255	32
Sn-X-L/FMT_A_So_MI_Label[1...M]	16 to (2**20)-1	Note-2--
Sn-X-L/FMT_A_So_MI_LSPTType[1...M]	E-LSP, L-LSP	Note-1--
Sn-X-L/FMT_A_So_MI_PSCCoS[1...M]	Note-10..7	Note-1
Sn-X-L/FMT_A_So_PHB2TCExpMapping[1...M]	Note-1	Note-1
Sn-X-L/FMT_A_So_MI_QoSEncodingMode[1...M]	A, B	Note-1--
<u>Sn-X-L/MT_A_Sk Provisioning</u>		
Sn-X-L/FMT_A_Sk_MI_SCCType (See Table 6-3 of G.7041)	0..255	32
Sn-X-L/FMT_A_Sk_MI_Label[1...M]	16 to (2**20)-1	Note-2--
Sn-X-L/FMT_A_Sk_MI_LSPTType[1...M]	E-LSP, L-LSP	Note-1--
Sn-X-L/FMT_A_Sk_MI_PSCCoS[1...M]	Note-10..7	Note-1
Sn-X-L/FMT_A_Sk_MI_EXP2PHBMapping[1...M]	Note-1	Note-1
Sn-X-L/FMT_A_Sk_MI_QoSDecodingMode[1...M]	A, B	Note-1--
Sn-X-L/MT_A_Sk_MI_LCK_Period[1...M]	1 s, 1 min	1 s
Sn-X-L/MT_A_Sk_MI_LCK_CoS[1...M]	0..7	--
Sn-X-L/MT_A_Sk_MI_Admin_State	LCK, Normal	Normal
Sn-X-L/MT_A_Sk_MI_AIS_Period[1...M]	1 s, 1 min	1 s
Sn-X-L/MT_A_Sk_MI_AIS_CoS[1...M]	0..7	--
Sn-X-L/MT_A_Sk_MI_GAL_Enable [1...M]	true, false	false
<u>Sn-X-L/MT_A_Sk Reporting</u>		
Sn-X-L/FMT_A_Sk_MI_AcSL (see Table 9-11 of G.707)	0..255	--
Sn-X-L/FMT_A_Sk_MI_AcEXI (see Table 6-2 of G.7041)	0..15	--
Sn-X-L/FMT_A_Sk_MI_LastValidUPI (see Table 6-3 of G.7041)	0..255	--
<u>Sm/MT_A_So Provisioning</u>		
Sm/FMT_A_So_MI_SCCType	0..255	32
Sm/FMT_A_So_MI_Label[1...M]	16 to (2**20)-1	Note-2--

Formatted: English (U.S.)

Formatted Table

Formatted: Not Highlight

Formatted: English (U.S.)

Formatted Table

Formatted Table

Formatted: German (Germany)

Formatted Table

Formatted: German (Germany)

Formatted: German (Germany)

Formatted: German (Germany)

Formatted: German (Germany)

Formatted Table

Formatted: English (U.S.)

Formatted Table

Formatted: German (Germany)

MI Signal	Value Range	Default Value
Sm/FMT_A_So_MI_LSPTType[1...M]	E-LSP, L-LSP	Note 1 --
Sm/FMT_A_So_MI_PSCCoS[1...M]	Note 4 0..7	Note 4 --
Sm/FMT_A_So_PHB2TCEXPMapping[1...M]	Note-1	Note-1
Sm/FMT_A_So_MI_QoSEncodingMode[1...M]	A, B	Note-1 --
<u>Sm/MT_A_Sk Provisioning</u>		
Sm/FMT_A_Sk_MI_SCCType	0..255	32
Sm/FMT_A_Sk_MI_Label[1...M]	16 to (2**20)-1	Note-2 --
Sm/FMT_A_Sk_MI_LSPTType[1...M]	E-LSP, L-LSP	Note 1 ---
Sm/FMT_A_Sk_MI_PSCCoS[1...M]	Note 4 0..7	Note 4 --
Sm/FMT_A_Sk_MI_EXPTC2PHBMapping[1...M]	Note-1	Note-1
Sm/FMT_A_Sk_MI_QoSDecodingMode[1...M]	A, B	Note-1 --
Sm/MT_A_Sk_MI_LCK_Period[1...M]	1 s, 1 min	1 s
Sm/MT_A_Sk_MI_LCK_CoS[1...M]	0..7	--
Sm/MT_A_Sk_MI_Admin_State	LCK, Normal	Normal
Sm/MT_A_Sk_MI_AIS_Period[1...M]	1 s, 1 min	1 s
Sm/MT_A_Sk_MI_AIS_CoS[1...M]	0..7	--
Sm/MT_A_Sk_MI_GAL_Enable[1...M]	true, false	false
<u>Sm/MT_A_Sk Reporting</u>		
Sm/FMT_A_Sk_MI_AcSL (see Table 9-12 and Table 9-13 of G.707)	0..255	--
Sm/FMT_A_Sk_MI_AcEXI (see Table 6-2 of G.7041)	0..15	--
Sm/FMT_A_Sk_MI_LastValidUPI (see Table 6-3 of G.7041)	0..255	--
<u>Sm-X-L/MT_A_So Provisioning</u>		
Sm-X-L/FMT_A_So_MI_SCCType	0..255	32
Sm-X-L/FMT_A_So_MI_Label[1...M]	16 to (2**20)-1	Note-2 --
Sm-X-L/FMT_A_So_MI_LSPTType[1...M]	E-LSP, L-LSP	Note 1 --
Sm-X-L/FMT_A_So_MI_PSCCoS[1...M]	Note 4 0..7	Note 4 --
Sm-X-L/FMT_A_So_PHB2EXPTCMapping[1...M]	Note-1	Note-1
Sm-X-L/FMT_A_So_MI_QoSEncodingMode[1...M]	A, B	Note-1 --
<u>Sm-X-L/MT_A_Sk Provisioning</u>		
Sm-X-L/FMT_A_Sk_MI_SCCType	0..255	32
Sm-X-L/FMT_A_Sk_MI_Label[1...M]	16 to (2**20)-1	Note-2 --
Sm-X-L/FMT_A_Sk_MI_LSPTType[1...M]	E-LSP, L-LSP	Note 1 --
Sm-X-L/FMT_A_Sk_MI_PSCCoS[1...M]	Note 4 0..7	Note 4 --
Sm-X-L/FMT_A_Sk_MI_EXPTC2PHBMapping[1...M]	Note-1	Note-1
Sm-X-L/FMT_A_Sk_MI_QoSDecodingMode[1...M]	A, B	Note-1 --
Sm-X-L/MT_A_Sk_MI_LCK_Period[1...M]	1 s, 1 min	1 s
Sm-X-L/MT_A_Sk_MI_LCK_CoS[1...M]	0..7	--
Sm-X-L/MT_A_Sk_MI_Admin_State	LCK, Normal	Normal

Formatted: English (U.S.)

Formatted Table

Formatted: English (U.S.)

Formatted Table

Formatted: German (Germany)

Formatted: German (Germany)

Formatted: German (Germany)

Formatted: German (Germany)

Formatted: English (U.S.)

Formatted Table

Formatted: English (U.S.)

Formatted Table

Formatted: German (Germany)

Formatted: English (U.S.)

Formatted Table

Formatted: German (Germany)

Formatted: German (Germany)

Formatted: German (Germany)

Formatted: German (Germany)

MI Signal	Value Range	Default Value
Sm-X-L/MT A Sk MI AIS Period[1...M]	1 s, 1 min	1 s
Sn-X-L/MT A Sk MI AIS CoS[1...M]	0..7	--
Sm-X-L/MT A Sk MI GAL Enable[1...M]	true, false	false
<u>Sm-X-L/MT A Sk Reporting</u>		
Sm-X-L/FMT A Sk MI AcSL	0..255	--
Sm-X-L/FMT A Sk MI AcEXI	0..15	--
Sm-X-L/FMT A Sk MI LastValidUPI	0..255	--
<u>Pq/MT A So Provisioning</u>		
Pq/FMT A So MI SCCType	0..255	32
Pq/FMT A So MI Label[1...M]	16 to (2**20)-1	Note-2--
Pq/FMT A So MI LSPTType[1...M]	E-LSP, L-LSP	Note-1--
Pq/FMT A So MI PSCCoS[1...M]	Note-10..7	Note-1--
Pq/FMT A So PHB2TCEXPMapping[1...M]	Note-1	Note-1
Pq/FMT A So MI QoSEncodingMode[1...M]	A, B	Note-1--
<u>Pq/MT A Sk Provisioning</u>		
Pq/FMT A Sk MI SCCType	0..255A, B	--32
Pq/FMT A Sk MI Label[1...M]	16 to (2**20)-1A, B	--Note-2
Pq/FMT A Sk MI LSPTType[1...M]	E-LSP, L-LSPA, B	Note-1--
Pq/FMT A Sk MI PSCCoS[1...M]	Note-10..7	Note-1--
Pq/FMT A Sk MI EXP2TC2PHBMapping[1...M]	Note-1	Note-1
Pq/FMT A Sk MI QoSDecodingMode[1...M]	A, B	Note-1--
Pq/MT A Sk MI LCK_Period[1...M]	1 s, 1 min	1 s
Pq/MT A Sk MI LCK CoS[1...M]	0..7	--
Pq/MT A Sk MI Admin State	LCK, Normal	Normal
Pq/MT A Sk MI AIS Period[1...M]	1 s, 1 min	1 s
Pq/MT A Sk MI AIS CoS[1...M]	0..7	--
Pq/MT A Sk MI GAL Enable [1...M]	true, false	false
<u>Pq/MT A Sk Reporting</u>		
Pq/FMT A Sk MI AcSL (see Clause 2.1.2 of G.832)	0..7	--
Pq/FMT A Sk MI AcEXI (see Table 6-2 of G.7041)	0..15	--
Pq/FMT A Sk MI LastValidUPI (see Table 6-3 of G.7041)	0..255	--
<u>Pq-X-L/MT A So Provisioning</u>		
Pq-X-L/FMT A So MI SCCType	0..255	32
Pq-X-L/FMT A So MI Label[1...M]	16 to (2**20)-1	--Note-2
Pq-X-L/FMT A So MI LSPTType[1...M]	E-LSP, L-LSP	--Note-1--
Pq-X-L/FMT A So MI PSCCoS[1...M]	Note-10..7	Note-1--
Pq-X-L/FMT A So PHB2TCEXPMapping[1...M]	Note-1	Note-1
Pq-X-L/FMT A So MI QoSEncodingMode[1...M]	A, B	Note-1--

Formatted: English (U.S.)

Formatted Table

Formatted: English (U.S.)

Formatted Table

Formatted: English (U.S.)

Formatted Table

Formatted: German (Germany)

Formatted: German (Germany)

Formatted: English (U.S.)

Formatted: German (Germany)

Formatted Table

Formatted: German (Germany)

Formatted: German (Germany)

Formatted: German (Germany)

Formatted: German (Germany)

Formatted: German (Germany)

Formatted: English (U.S.)

Formatted: English (U.S.)

Formatted: English (U.S.)

Formatted Table

Formatted: English (U.S.)

Formatted Table

Formatted: German (Germany)

Formatted: German (Germany)

MI Signal	Value Range	Default Value
<u>Pq-X-L/MT A Sk Provisioning</u>		
<u>Pq-X-L/FMT A Sk MI SCCType</u>	0..255	32
<u>Pq-X-L/FMT A Sk MI Label[1...M]</u>	16 to (2**20)-1	-- <u>Note-2</u>
<u>Pq-X-L/FMT A Sk MI LSPTType[1...M]</u>	E-LSP, L-LSP	-- <u>Note 1--</u>
<u>Pq-X-L/FMT A Sk MI PSCCoS[1...M]</u>	<u>Note 40..7</u>	<u>Note 1--</u>
<u>Pq-X-L/FMT A Sk MI EXPIC2PHBMapping[1...M]</u>	Note-1	Note-1
<u>Pq-X-L/FMT A Sk MI QoSDecodingMode[1...M]</u>	A, B	<u>Note-1--</u>
<u>Pq-X-L/MT A Sk MI LCK Period[1...M]</u>	1 s, 1 min	1 s
<u>Pq-X-L/MT A Sk MI LCK CoS[1...M]</u>	0..7	--
<u>Pq-X-L/MT A Sk MI Admin_State</u>	LCK, Normal	Normal
<u>Pq-X-L/MT A Sk MI AIS Period[1...M]</u>	1 s, 1 min	1 s
<u>Pq-X-LMT A Sk MI AIS CoS[1...M]</u>	0..7	--
<u>Pq-X-L/MT A Sk MI GAL Enable[1...M]</u>	true, false	false
<u>Pq-X-L/MT A Sk Reporting</u>		
<u>Pq-X-L/FMT A Sk MI AcSL</u>	0..7	--
<u>Pq-X-L/FMT A Sk MI AcEXI</u>	0..15	--
<u>Pq-X-L/FMT A Sk MI LastValidUPI</u>	0..255	--
<u>ODUkP/MT A So Provisioning</u>		
<u>ODUkP/FMT A So MI Active</u>	true, false	false
<u>ODUkP/FMT A So MI SCCType</u>	0..255	32
<u>ODUkP/FMT A So MI Label[1...M]</u>	16 to (2**20)-1	-- <u>Note-2</u>
<u>ODUkP/FMT A So MI LSPTType[1...M]</u>	E-LSP, L-LSP	-- <u>Note 1--</u>
<u>ODUkP/FMT A So MI PSCCoS[1...M]</u>	<u>Note 40..7</u>	<u>Note 1--</u>
<u>ODUkP/FMT A So PHB2ICEXPMapping[1...M]</u>	Note-1	Note-1
<u>ODUkP/FMT A So MI QoSEncodingMode[1...M]</u>	A, B	<u>Note-1--</u>
<u>ODUkP/MT A Sk Provisioning</u>		
<u>ODUkP/FMT A Sk MI Active</u>	true, false	false
<u>ODUkP/FMT A Sk MI SCCType</u>	0..255	32
<u>ODUkP/FMT A Sk MI Label[1...M]</u>	16 to (2**20)-1	-- <u>Note-2</u>
<u>ODUkP/FMT A Sk MI LSPTType[1...M]</u>	E-LSP, L-LSP	-- <u>Note 1--</u>
<u>ODUkP/FMT A Sk MI PSCCoS[1...M]</u>	<u>Note 40..7</u>	<u>Note 1--</u>
<u>ODUkP/FMT A Sk MI EXPIC2PHBMapping[1...M]</u>	Note-1	Note-1
<u>ODUkP/FMT A Sk MI QoSDecodingMode[1...M]</u>	A, B	<u>Note-1--</u>
<u>ODUkP/MT A Sk MI LCK Period[1...M]</u>	1 s, 1 min	1 s
<u>ODUkP/MT A Sk MI LCK CoS[1...M]</u>	0..7	--
<u>ODUkP/MT A Sk MI Admin_State</u>	LCK, Normal	Normal
<u>ODUkP/MT A Sk MI AIS Period[1...M]</u>	1 s, 1 min	1 s
<u>ODUkP/MT A Sk MI AIS CoS[1...M]</u>	0..7	--
<u>ODUkP/MT A Sk MI GAL Enable[1...M]</u>	true, false	false

Formatted: English (U.S.)

Formatted Table

Formatted: English (U.S.)

Formatted: German (Germany)

Formatted Table

Formatted: German (Germany)

Formatted: German (Germany)

Formatted: German (Germany)

Formatted: German (Germany)

Formatted: German (Germany)

Formatted: English (U.S.)

Formatted: English (U.S.)

Formatted: English (U.S.)

Formatted: German (Germany)

Formatted Table

Formatted: German (Germany)

Formatted Table

Formatted: German (Germany)

Formatted: German (Germany)

Formatted: German (Germany)

Formatted: German (Germany)

Formatted: German (Germany)

Formatted Table

Formatted: German (Germany)

Formatted: German (Germany)

Formatted: German (Germany)

Formatted: German (Germany)

Formatted: German (Germany)

Formatted: German (Germany)

Formatted: German (Germany)

Formatted: German (Germany)

Formatted: German (Germany)

Formatted: English (U.S.)

Formatted: English (U.S.)

Formatted: English (U.S.)

MI Signal	Value Range	Default Value
<u>ODUKP/MT A Sk Reporting</u>		
ODUKP/FMT A_Sk_MI_AcPT (see Table 15-8 of G.709)	0..255	--
ODUKP/FMT A_Sk_MI_AcEXI (see Table 6-2 of G.7041)	0..15	--
ODUKP/FMT A_Sk_MI_LastValidUPI (see Table 6-3 of G.7041)	0..255	--
<u>ODUKP-X-L/MT A So Provisioning</u>		
ODUKP-X-L/FMT A_So_MI_Active	true, false	false
ODUKP-X-L/FMT A_So_MI_SCCType	0..255	32
ODUKP-X-L/FMT A_So_MI_Label[1...M]	16 to (2**20)-1	--Note-2
ODUKP-X-L/FMT A_So_MI_LSPTType[1...M]	E-LSP, L-LSP	--Note-1--
ODUKP-X-L/FMT A_So_MI_PSCTCoS[1...M]	Note-10_7	Note-1--
ODUKP-X-L/FMT A_So_PHB2TCEXPMapping[1...M]	Note-1	Note-1
ODUKP-X-L/FMT A_So_MI_QoSEncodingMode[1...M]	A, B	Note-1--
<u>ODUKP-X-L/MT A Sk Provisioning</u>		
ODUKP-X-L/FMT A_Sk_MI_Active	true, false	false
ODUKP-X-L/FMT A_Sk_MI_SCCType	0..255	32
ODUKP-X-L/FMT A_Sk_MI_Label[1...M]	16 to (2**20)-1	--Note-2
ODUKP-X-L/FMT A_Sk_MI_LSPTType[1...M]	E-LSP, L-LSP	--Note-1--
ODUKP-X-L/FMT A_Sk_MI_PSCTCoS[1...M]	Note-10_7	Note-1--
ODUKP-X-L/FMT A_Sk_MI_EXPTC2PHBMapping[1...M]	Note-1	Note-1
ODUKP-X-L/FMT A_Sk_MI_QoSDecodingMode[1...M]	A, B	Note-1--
ODUKP-X-L/MT A_Sk_MI_LCK_Period[1...M]	1 s, 1 min	1 s
ODUKP-X-L/MT A_Sk_MI_LCK_CoS[1...M]	0..7	==
ODUKP-X-L/MT A_Sk_MI_Admin_State	LCK_Normal	Normal
ODUKP-X-L/MT A_Sk_MI_AIS_Period[1...M]	1 s, 1 min	1 s
ODUKP-X-L/MT A_Sk_MI_AIS_CoS[1...M]	0..7	==
ODUKP-X-L/MT A_Sk_MI_GAL_Enable[1...M]	true, false	false
<u>ODUKP-X-L/MT A Sk Reporting</u>		
ODUKP-X-L/FMT A_Sk_MI_AcVcPT (see Table 15-8 of G.709)	0..255	--
ODUKP-X-L/FMT A_Sk_MI_AcEXI (see Table 6-2 of G.7041)	0..15	--
ODUKP-X-L/FMT A_Sk_MI_LastValidUPI (see Table 6-3 of G.7041)	0..255	--
<u>ETYn/MT A So Provisioning</u>		
ODUKP/MT A So MI_SCCType	0..255	32

Formatted: English (U.S.)

Formatted Table

Formatted Table

Formatted Table

Formatted: German (Germany)

Formatted: German (Germany)

Formatted: German (Germany)

Formatted: German (Germany)

Formatted: German (Germany)

Formatted Table

Formatted: German (Germany)

Formatted: German (Germany)

Formatted: German (Germany)

Formatted: German (Germany)

Formatted: German (Germany)

Formatted: German (Germany)

Formatted: English (U.S.)

Formatted: English (U.S.)

Formatted Table

MI Signal	Value Range	Default Value
<u>ETYN/MT_A_So_MI_Label[1...M]</u>	<u>16 to (2**20) 1</u>	<u>Note 2</u>
<u>ETYN/MT_A_So_MI_LSPTType[1...M]</u>	<u>E-LSP, L-LSP</u>	<u>=</u>
<u>ETYN/MT_A_So_MI_CoS[1...M]</u>	<u>0..7</u>	<u>=</u>
<u>ETYN/MT_A_So_PHB2TCMapping[1...M]</u>	<u>Note 1</u>	<u>Note 1</u>
<u>ETYN/MT_A_So_MI_OoSEncodingMode[1...M]</u>	<u>A, B</u>	<u>Note 1</u>
<u>ETYN/MT_A_So_MI_TxPauseEnable</u>	<u>true, false</u>	<u>false</u>
<u>ETYN/MT_A_Sk Provisioning</u>		
<u>ETYN/MT_A_Sk_MI_FilterConfig</u>	<u>Note 1</u>	<u>=</u>
<u>ETYN/MT_A_Sk_MI_Frame_Type_Config</u>		
<u>ETYN/MT_A_Sk_MI_Etype</u>	<u>2 byte integer</u> <u>≥ 0x0600</u>	<u>S-Tag: 0x88a8</u> <u>C-Tag: 0x8100</u>
<u>ETYN/MT_A_Sk_MI_MAC_Length</u>	<u>1518, 1522, 2000</u>	<u>2000</u>
<u>ETYN/MT_A_Sk_MI_LCK_Period[1...M]</u>	<u>1 s, 1 min</u>	<u>1 s</u>
<u>ETYN/MT_A_Sk_MI_LCK_CoS[1...M]</u>	<u>0..7</u>	<u>=</u>
<u>ETYN/MT_A_Sk_MI_Admin_State</u>	<u>LCK, Normal</u>	<u>Normal</u>
<u>ETYN/MT_A_Sk_MI_AIS_Period[1...M]</u>	<u>1 s, 1 min</u>	<u>1 s</u>
<u>ETYN/MT_A_Sk_MI_AIS_CoS[1...M]</u>	<u>0..7</u>	<u>=</u>

Formatted: English (U.S.)

Formatted Table

Formatted: German (Germany)

Formatted: English (U.S.)

Formatted: English (U.S.)

Formatted: German (Germany)

Formatted: English (U.S.)

Formatted: German (Germany)

Formatted: German (Germany)

Formatted: German (Germany)

Formatted: English (U.S.)

Formatted: English (U.S.)

Note-1: According to [ITU-T G.8121/Y.1381+744]

Note-2: A value must be provided at provisioning.

For MT.NE that supports the adaptation functions specified in [ITU-T G.8121.1/Y.1381.1], there is no additional MI to be managed beyond those listed in Table 8-2 above.

For MT.NE that supports the adaptation functions specified in [ITU-T G.8121.2/Y.1381.2], there is no additional MI to be managed beyond those listed in Table 8-2 above.

8.6 Diagnostic

This section provides the requirements for the management of the MT Diagnostic Trail Termination Functions (MTDe_TT)

For MT.NE that supports the MTDe_TT function specified in [ITU-T G.8121/Y.1381], the EMF shall support the following management functions for the MIs listed in Table 8-3 below:

- Provisioning the trail termination management information
- Retrieving the trail termination management information
- Notifying the changes of the trail termination management information
- Receiving the monitored trail termination management information

Formatted: Left

Formatted: Font: Bold

Formatted: Font: Bold

Formatted: Font: Bold

Formatted: Centered

Table 8-3 G.8151/Y.1374 – Provisioning and reporting for diagnostic trail termination function

<u>MI Signal</u>	<u>Value Range</u>	<u>Default Value</u>
<u>Me1</u>		
<u>MTDe_FTT_So_MI_IDMo_OAM_Tool</u>	<u>G.8113.1, G.8113.2</u>	<u>N/AG.8113.2</u>
<u>MTDe_FTT_So_MI_IDMo_Start(CoS,Test ID,Length,Period)[1...M_IDMo]</u>	CoS: 0..7 Test_ID: (Note 2) Length: ?? Period: 100ms, 1s, 10s	==
<u>MTDe_FTT_So_MI_IDMo_Terminate[1...M_IDMo]</u>	==	==
<u>MTDe_FTT_So_MI_SLo_OAM_Tool</u>	<u>G.8113.1, G.8113.2</u>	<u>N/AG.8113.2</u>
<u>MTDe_FTT_So_MI_SLo_Start(CoS,Test ID,Length,Period)[1...M_SLo]</u>	CoS: 0..7 Test_ID: (Note 2) Length: ?? Period: 100ms, 1s, 10s	==
<u>MTDe_FTT_So_MI_SLo_Terminate[1...M_SLo]</u>	==	
<u>MTDe_TT_So Reporting</u>		
<u>MTDe_TT_So_MI_CV_Series_Result(REC,ERR,OO)</u>	==	==
<u>MTDe_TT_So_MI_RT_Result(<MIP_ID>,MEP_ID)</u>	==	==
<u>MTDe_TT_So_MI_DT_Result(Sent, REC, CRC, BER, OO)</u>	==	==
<u>MTDe_TT_So_MI_1THDTF_Result(Sent)</u>	==	==
<u>MTDe_TT_So_MI_LMo_Result(N_TF,N_LF,F_TF,F_LF)[1...M_LMo]</u>	==	==
<u>MTDe_TT_So_MI_DMo_Result(count,B_FD[,F_FD[,N_FD][1...M_DMo]</u>	==	==
<u>MTDe_TT_So_MI_SLo_Result(N_TF,N_LF,F_TF,F_LF)[1...M_SLo]</u>	==	==
<u>MTDe_FTT_Sk Provisioning</u>		
<u>MTDe_FTT_Sk_MI_GAL_Enable</u>	true, false	false
<u>MTDe_FTT_Sk_MI_MEG_ID</u>	String: values are OAM protocol-specific P-based: To be provided ICC based: 15 byte string	Note-1
<u>MTDe_FTT_Sk_MI_PeerMEP_ID</u>	String: values are OAM protocol-specific P-based: To be provided ICC based: 16 bit integer	Note-1
<u>MTDe_FTT_Sk_MI_CV_OAM_Tool</u>	<u>G.8113.1, G.8113.2</u>	<u>N/AG.8113.2</u>
<u>MTDe_FTT_Sk_MI_RT_OAM_Tool</u>	<u>G.8113.1, G.8113.2</u>	<u>N/AG.8113.2</u>
<u>MTDe_FTT_Sk_MI_DT_OAM_Tool</u>	<u>G.8113.1, G.8113.2</u>	<u>N/AG.8113.2</u>
<u>MTDe_FTT_Sk_MI_1THDTF_OAM_Tool</u>	<u>G.8113.1, G.8113.2</u>	<u>N/AG.8113.2</u>

Formatted Table

Formatted

Formatted

Formatted

Formatted

Formatted

Formatted

Formatted

Formatted

Formatted

Formatted

Formatted

Formatted

Formatted

Formatted

Formatted

Formatted

Formatted

Formatted

Formatted

Formatted

Formatted

Formatted

Formatted

Formatted

Formatted

Formatted

Formatted

Formatted

Formatted

Formatted

Formatted

Formatted

Formatted

Formatted

Formatted

Formatted

Formatted

Formatted

Formatted

Formatted

Formatted

Formatted

Formatted

Formatted

Formatted

Formatted

Formatted

Formatted

Formatted

Formatted

<u>MI Signal</u>	<u>Value Range</u>	<u>Default Value</u>
<u>MTDe_FTT_Sk_MI_1THDT_Start(Patte</u> <u>#)</u>	<u>Pattern: 22</u>	<u>--</u>
<u>MTDe_FTT_Sk_MI_1THDT_Terminate</u>	<u>--</u>	<u>--</u>
<u>MTDe_FTT_Sk_MI_LMo_OAM_Tool</u>	<u>G.8113.1, G.8113.2</u>	<u>N/AG.8113.2</u>
<u>MTDe_FTT_Sk_MI_DMo_OAM_Tool</u>	<u>G.8113.1, G.8113.2</u>	<u>N/AG.8113.2</u>
<u>MTDe_FTT_Sk_MI_IDMo_OAM_Tool</u>	<u>G.8113.1, G.8113.2</u>	<u>N/AG.8113.2</u>
<u>MTDe_FTT_Sk_MI_IDMo_Start(Test_I</u> <u>D)[L...M_IDMo]</u>	<u>--(Note 2)</u>	<u>--</u>
<u>MTDe_FTT_Sk_MI_IDMo_Terminatef</u> <u>L...M_IDMo]</u>	<u>--</u>	<u>--</u>
<u>MTDe_FTT_Sk_MI_SLo_OAM_Tool</u>	<u>G.8113.1, G.8113.2</u>	<u>N/AG.8113.2</u>
<u>MTDe_TT_Sk Reporting</u>		
<u>MTDe_TT_Sk_MI_1TH_Result(REC.CRC.BER</u> <u>OO)</u>	<u>--</u>	<u>--</u>
<u>MTDe_TT_Sk_MI_IDMo_Result(count.N_FD[</u> <u>L...M_IDMo]</u>	<u>--</u>	<u>--</u>
<u>MTDi_TT_So Provisioning</u>		
<u>MTDi_TT_So_MI_GAL_Enable</u>	<u>true, false</u>	<u>false</u>
<u>MTDi_TT_So_MI_TTLVALUE</u>	<u>0..255</u>	<u>255</u>
<u>MTDe_TT_So_MI_MIP_ID</u>	<u>16 bit integer</u>	<u>Note 1</u>
<u>MTDi_TT_So_MI_CV_OAM_Tool</u>	<u>G.8113.1, G.8113.2</u>	<u>N/AG.8113.2</u>
<u>MTDi_TT_So_MI_RT_OAM_Tool</u>	<u>G.8113.1, G.8113.2</u>	<u>G.8113.2</u>
<u>MTDi_TT_Sk Provisioning</u>		
<u>MTDi_TT_Sk_MI_GAL_Enable</u>	<u>true, false</u>	<u>false</u>
<u>MTDe_TT_Sk_MI_MIP_ID</u>	<u>16 bit integer</u>	<u>Note 1</u>
<u>MTDi_TT_Sk_MI_CV_OAM_Tool</u>	<u>G.8113.1, G.8113.2</u>	<u>N/AG.8113.2</u>
<u>MTDi_TT_Sk_MI_RT_OAM_Tool</u>	<u>G.8113.1, G.8113.2</u>	<u>G.8113.2</u>

Note-1: A value must be provided at provisioning.

Note-2: The Test ID field is optional when this proactive measurement tool is used.

For MT-NE that supports the MTDe_TT function specified in [ITU-T G.8121.1/Y.1381.1], there is no additional MIs to be managed beyond those listed in Table 8-3 above.

For MT-NE that supports the MT_TT function specified in [ITU-T G.8121.2/Y.1381.2], the EME shall in addition support the management of the MIs listed in Table 8-3.2 below.

Formatted Table

Formatted: German (Germany)

Formatted: German (Germany)

Formatted: Highlight

Formatted: German (Germany)

Formatted: German (Germany)

Formatted: German (Germany)

Formatted: German (Germany)

Formatted: German (Germany)

Formatted: German (Germany)

Formatted: German (Germany)

Formatted: German (Germany)

Formatted: German (Germany)

Formatted: German (Germany)

Formatted: German (Germany)

Formatted: German (Germany)

Formatted: German (Germany)

Formatted: German (Germany)

Formatted: German (Germany)

Formatted: German (Germany)

Formatted: German (Germany)

Formatted: German (Germany)

Formatted: German (Germany)

Formatted: German (Germany)

Formatted: German (Germany)

Formatted: German (Germany)

Formatted: German (Germany)

Formatted: German (Germany)

Formatted: Not Highlight

Formatted: English (U.S.), Not Highlight

Formatted: Not Highlight

Formatted: English (U.S.), Not Highlight

Formatted: Not Highlight

Formatted: English (U.S.)

Formatted: Font: Italic

Formatted: German (Germany)

Formatted: German (Germany)

Formatted: German (Germany)

Table 8.3.2/G.8151/Y.1374 – Provisioning and reporting for termination functions

<u>MI Signal</u>	<u>Value Range</u>	<u>Default Value</u>
<u>MTDe_TT_Sk Provisioning</u>		
MTDe_TT_Sk_MI_ODCV_Ping	See on demand ev	--
MTDe_TT_Sk_MI_ODCV_Trace	See on demand ev	--
<u>MTDe_TT_Sk Reporting</u>		
MTDe_TT_Sk_MI_ODCV_Ping_Result	See on demand ev	--
MTDe_TT_Sk_MI_ODCV_Trace_Result	See on demand ev	--
MTDe_TT_Sk_MI_ODCV_FWErr	See on demand ev	--
MTDe_TT_Sk_MI_ODCV_BWErr	See on demand ev	--
<u>MTDi_TT_So Provisioning</u>		
MTDi_TT_So_MI_Target_FEC	See on demand ev	--
MTDi_TT_So_MI_Hnum	See on demand ev	--
MTDi_TT_So_MI_MTU	See on demand ev	--
<u>MTDi_TT_Sk Provisioning</u>		
MTDi_TT_Sk_MI_FEC_Checking	See on demand ev	--

Formatted: German (Germany)

Formatted: German (Germany)

Formatted: German (Germany)

Formatted: German (Germany)

8.68.7 Connection

See section 8.6 of [ITU-T G.7710/Y.1701] for a description of connection management.

This function allows a user to provision the operation of a T-MPLS-TP Connection process.

The MI signals listed in the following table in this subclause are communicated from the EMF to the Connection process through the management point.

For MT.NE that supports the MT_C function specified in [ITU-T G.8121/Y.1381], the EMF shall support the following management functions for the MIs listed in Table 8-4 below:

- Provisioning the trail termination management information
- Retrieving the trail termination management information
- Notifying the changes of the trail termination management information

Formatted: Bullets and Numbering

Formatted: Bulleted + Level: 1 + Aligned at: 0.63 cm + Tab after: 1.27 cm + Indent at: 1.27 cm

Table 8.43/G.8151/Y.1374 – Provisioning and reporting for connection functions

<u>MI Signal</u>	<u>Value Range</u>	<u>Default Value</u>
<u>MT_C Provisioning (Per matrix connection)</u>		
MT_C_MI_ConnectionType	Protected, unprotected	--unprotected
MT_C_MI_Return_CP_ID	NULL (for unidirectional), or the Connection point (CP) identifier (for bidirectional)	--
MT_C_MI_ConnectionPortIds	Set of connection point identifiers	--

Formatted: Not Highlight

Formatted: Not Highlight

Note-1: According to [ITU-T G.8121/Y.1381+744]

For MT-NE that supports the MT-C functions specified in [ITU-T G.8121.1/Y.1381.1], there is no additional MI to be managed beyond those listed in Table 8-4 above.

For MT-NE that supports the MT-C functions specified in [ITU-T G.8121.2/Y.1381.2], there is no additional MI to be managed beyond those listed in Table 8-2 above.

Formatted: Bullets and Numbering

8-78.8 DEG Thresholds

For further study

Formatted: Bullets and Numbering

8-88.9 XXX_Reported

See section 8.8 of [ITU-T G.7710/Y.1701] for a description of XXX_Reported management.

Table 9-48-5 below provides the MI signals that need to be provisioned for consequential defect/failure.

Table 8-54/G.8151/Y.1374- Consequential defect/failure related provisioning

MI signal	Value range	Default value
MI_SSF_Reported	true, false	false
MI_BDI_Reported	true, false	false

Formatted: English (U.S.)

8-98.10 Alarm Severity

See section 8.9 of [ITU-T G.7710/Y.1701] for a description of alarm severity.

Formatted: Bullets and Numbering

8-108.11 Alarm Reporting Control (ARC)

See section 8.10 of [ITU-T G.7710/Y.1701] for a description of alarm report control.

Formatted: Bullets and Numbering

8-118.12 PM Thresholds

For further study

Formatted: Bullets and Numbering

8-128.13 TCM Activation

For further study

Formatted: Bullets and Numbering

8-138.14 Date & Time

The Date and Time Functions within the \mp -MPLS-TP EMF comprise the local Real Time Clock (RTC) function and the Performance Monitoring Clock (PMC) function. The Message Communication Function within the \mp -MPLS-TP NEF shall be capable of setting the local Real Time Clock function.

The date and time values are incremented by a free running local clock, or by an external timing source. The FCAPS functions need date and time information, e.g. to time stamp event reports. They obtain this information from the Date & Time Function.

Formatted: Bullets and Numbering

8-13-18.14.1 Date & Time Applications

Section 8.13.1 of [ITU-T G.7710/Y.1701] identifies three Date & Time applications. These are:

- Time stamping
- Performance Monitoring Clock signals
- Activity scheduling

Formatted: Bullets and Numbering

The ~~T~~-MPLS-TP NEF functional requirements for these applications are specified in the following subsections.

~~8.13.1.18.14.1.1~~ **Time-stamping**

See section 8.13.1.1 of [ITU-T G.7710/Y.1701] for a description of the time-stamping application.

~~8.13.1.28.14.1.2~~ **Performance Monitoring Clock Signals**

See section 8.13.1.2 of [ITU-T G.7710/Y.1701] for a description of the PMC signals.

~~8.13.1.38.14.1.3~~ **Activity Scheduling**

See section 8.13.1.3 of [ITU-T G.7710/Y.1701] for a description of the activity scheduling.

~~8.13.28.14.2~~ **Date & Time Functions**

There are three Date & Time functions defined. The local Real Time Clock (RTC) function is required for time stamping and activity scheduling. The Local Real Time Clock alignment function is required for aligning the clock with an External Time Reference. The Performance Monitoring Clock (PMC) function, in addition to RTC, is typical for digital counter measurements.

~~8.13.2.18.14.2.1~~ **Local Real Time Clock Function**

The local Real Time Clock function is specified in section 8.13.2.1 of [ITU-T G.7710/Y.1701].

~~8.13.2.28.14.2.2~~ **Local Real Time Clock alignment function with External Time Reference**

The Local Real Time Clock alignment function with External Time Reference is specified in section 8.13.2.2 of [ITU-T G.7710/Y.1701].

~~8.13.2.38.14.2.3~~ **Performance Monitoring Clock Function**

The Performance Monitoring Clock function is specified in section 8.13.2.3 of [ITU-T G.7710/Y.1701].

9 Accounting Management

For further study

10 Performance Management

See [ITU-T G.7710/Y.1701] Clause 10 for the generic requirements for performance management. ~~T~~-MPLS-TP specific management requirements are described below.

10.1 Performance management applications

See [ITU-T G.7710/Y.1701] Clause 10.1 for the generic description for performance management applications.

10.2 Performance monitoring functions

See [ITU-T G.7710/Y.1701] Clause 10.2 for generic requirements of performance monitoring functions.

~~T~~-MPLS-TP NE shall provides the following PM management information (see Table 10-1).

Formatted: Bullets and Numbering

Formatted: Bullets and Numbering

Formatted: Bullets and Numbering

Formatted: Bullets and Numbering

Formatted: Bullets and Numbering

Formatted: Bullets and Numbering

Formatted: Bullets and Numbering

Table 10-1/G.8151/Y.1374 – PM Management Information

PM Management Information	G.8121 Function
FMT₂_TT_Sk_MI_pN_LF	
FMT₂_TT_Sk_MI_pN_TF	
FMT₂_TT_Sk_MI_pF_LF	
FMT₂_TT_Sk_MI_pF_TF	
FMT₂_TT_Sk_MI_pF_DS	
FMT₂_TT_Sk_MI_pN_DS	FMT ₂ _TT_Sk
MT_TT_Sk_MI_pB_FD	
MT_TT_Sk_MI_pB_FD_V	
MT_TT_Sk_MI_pN_FD	
MT_TT_Sk_MI_pN_FD_V	
MT_TT_Sk_MI_pF_FD	
MT_TT_Sk_MI_pF_FD_V	
<u>ETYn/MT_A_Sk_MI_pErrors</u>	
<u>ETYn/MT_A_Sk_MI_pFramesReceivedOK</u>	
<u>ETYn/MT_A_Sk_MI_pOctetsReceivedOK</u>	<u>ETYn/MT_A_Sk</u>

Formatted: English (U.S.)

Formatted: English (U.S.)

Formatted: German (Germany)

Formatted: Table_text, Keep with next, Keep lines together

Formatted: German (Germany)

Formatted: Font: (Asian) Times New Roman, Font color: Auto, German (Germany)

Formatted: German (Germany)

Formatted: English (U.S.)

The EMF shall support the following functions:

- Notifying of the PM management information

11 Security management

See [ITU-T G.7710/Y.1701] for a description of security management.

Formatted: No bullets or numbering

Bibliography

The following is a list of non-normative references used by this Recommendation. These documents are used as supplementary information to assist the understanding of this Recommendation. Therefore, conformance to these documents is not necessary.

[b-IETF RFC 5951] IETF RFC 5951 (2010), MPLS-TP Network Management Requirements
