

IETF 100 – CCAMP WG

draft-dharinigert-ccamp-dwdm-if-Imp-05

Editors:

Dharini Hiremagalur	dharinih@juniper.net
Gert Grammel	ggrammel@juniper.net
Gabriele Galimberti	ggalimbe@cisco.com
Ruediger Kunze	RKunze@telekom.de
Dieter Beller	Dieter.Beller@nokia.com

draft-ggalimbe-ccamp-flex-if-Imp-03

Editors:

Dharini Hiremagalur	dharinih@juniper.net
Gert Grammel	ggrammel@juniper.net
Gabriele Galimberti	ggalimbe@cisco.com
Ruediger Kunze	RKunze@telekom.de

LMP Considerations

- LMP covers the discovery/parameter-negotiation use case
- LMP is not used for configuration or provisioning and there is no mentioning of configuration or provisioning in these drafts
- Discovery determines the limitations of the single channel interface to a WDM line system
- The parameter extension to SSON technology is needed
- Discovery determines the limitations of the multiple channel interface to a SSON line system

Changes from the previous versions

1. draft-dharinigert-ccamp-dwdm-if-Imp-05

- Corrected few typo
- Changed OADM into ROADM
- reshaped reference documents section

2. draft-ggalimbe-ccamp-flex-if-Imp-03

- Corrected few typo
- reshaped reference documents section
- Added 2 parameters
 - Max-pol-power-difference
 - Max-pol-skew-difference

Data Plane Reference Model

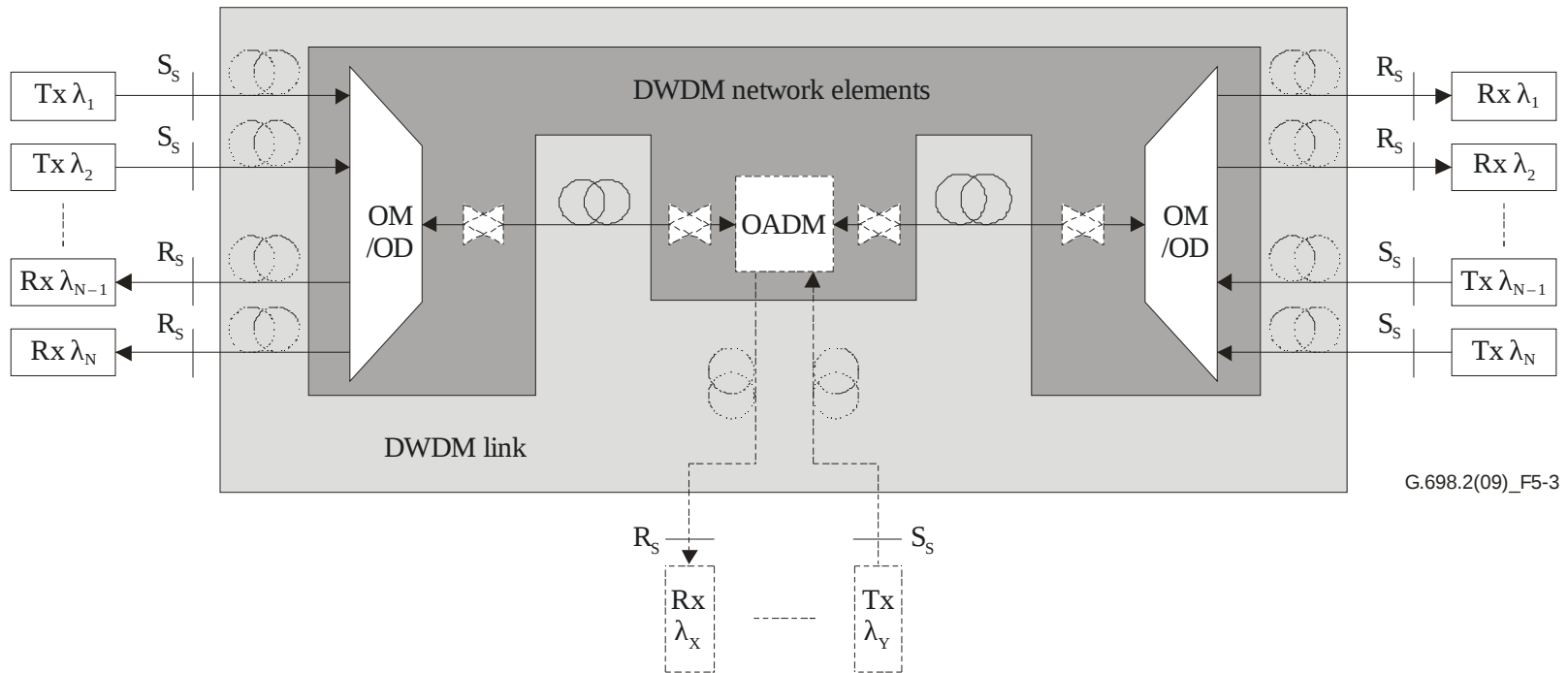

Figure 5-3 – Linear "black link" approach for bidirectional applications

draft-dharinigert-ccamp-dwdm-if-Imp-05

What is defined here:

- Extension to the Link Management Protocol (LMP/DWDM -rfc4209) for Dense Wavelength Division Multiplexing (DWDM) Optical Line Systems to manage the application code of optical interface parameters in DWDM application
- Output Power
- Current Input Power
- Input power range

draft-ggalimbe-ccamp-flex-if-Imp-03

The parameters added for SSON are:

1. Modulation identifier: indicates the Transceiver capabilities to support a single or multiple modulation format like: BPSK, DC-DP-BPSK, QPSK, DP-QPSK, QAM16, DP-QAM16, DC-DP-QAM16, QAM64, etc.
2. FEC: indicates the FEC types the transceiver can support
3. baud rate: number of symbols rate, basically this identifies the channel frequency
4. Number Carriers: number of subcarriers the transceiver can support and can be "mapped" in a Media Channel
5. Bits/symbol: number of bit per symbol (aka spectral efficiency)
6. Subcarrier band (minimum distance between subcarriers) in GHz required by the transceiver
7. Guard band (required guard band at the side of media channel)
8. Sub-carrier TX Power: output optical power the transceiver can provide
9. Sub-carrier RX Power: Input optical power Range the transceiver can support, this is known also as Sensitivity
10. Sub-carrier OSNR robustness
11. Max-pol-power-difference
12. Max-pol-skew-difference

Next Steps

- Solicit feedback/comments from the group.
- Achieve consensus
- Go to WG document request

Keep in mind: LMP is not for configuration!

Thank You!