



Compact Alternate Marking

Tal Mizrahi

Marvell

Carmi Arad

Marvell

Giuseppe Fioccola

Telecom Italia

Mauro Cociglio

Telecom Italia

Mach Chen

Huawei

Lianshu Zheng

Huawei

Greg Mirsky

ZTE

[draft-mizrahi-ippm-compact-alternate-marking-00](#)

IETF 100, Singapore, November 2017

Alternate Marking - Background

Monitor data traffic from MP 1 to MP 2

- Loss
- Delay

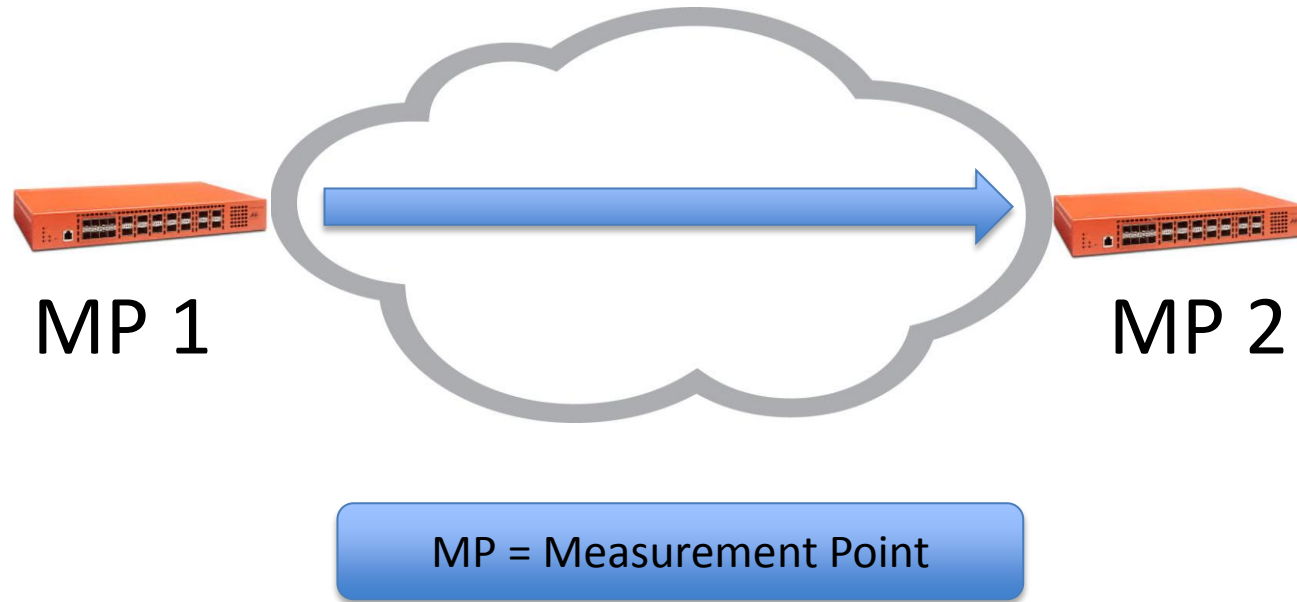

Alternate Marking (draft-ietf-ippm-alt-mark)

Every data packet includes a color bit.

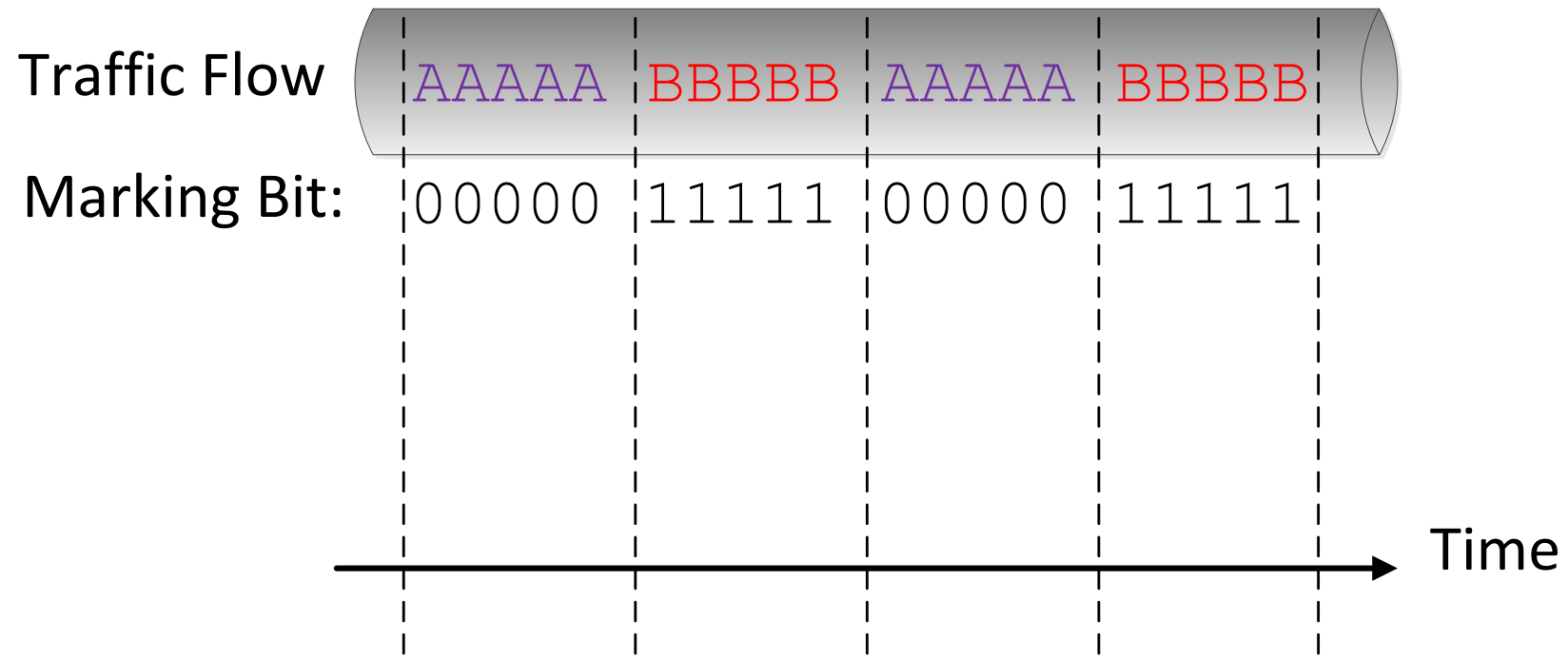
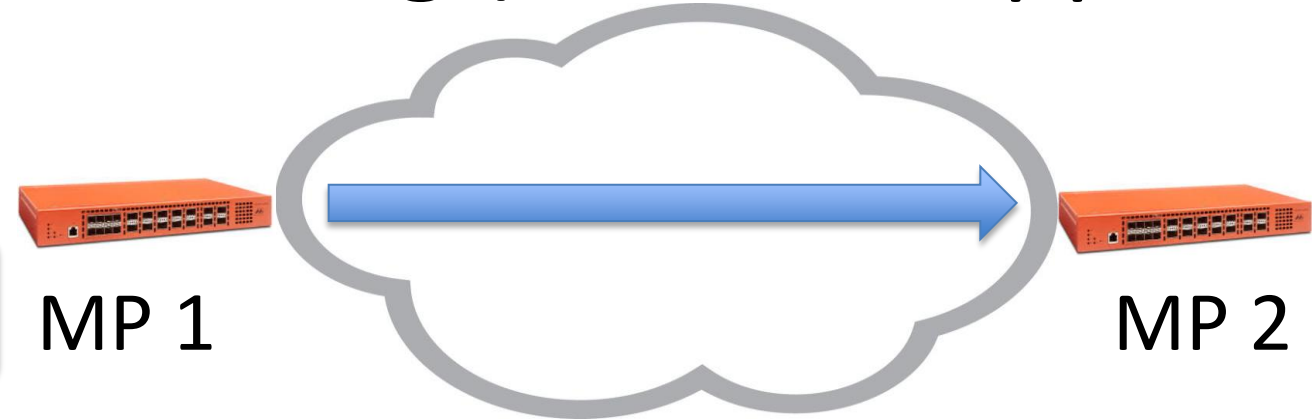

Scope of the Current Draft

- New alternate marking methods with low overhead.
 - Single bit per packet.
 - Zero bits per packet.
- Summary of alternate marking methods.

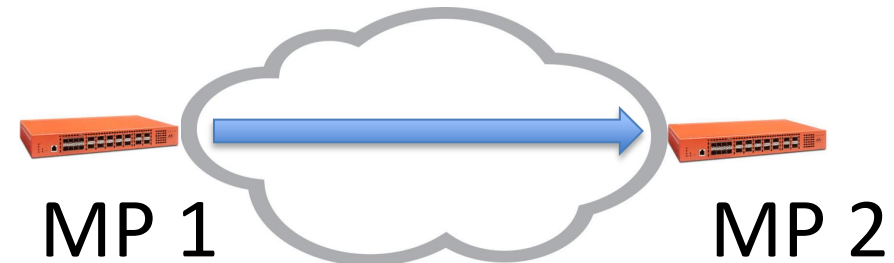

Existing Alternate Marking Methods (draft-ietf-ippm-alt-mark)

Double Marking

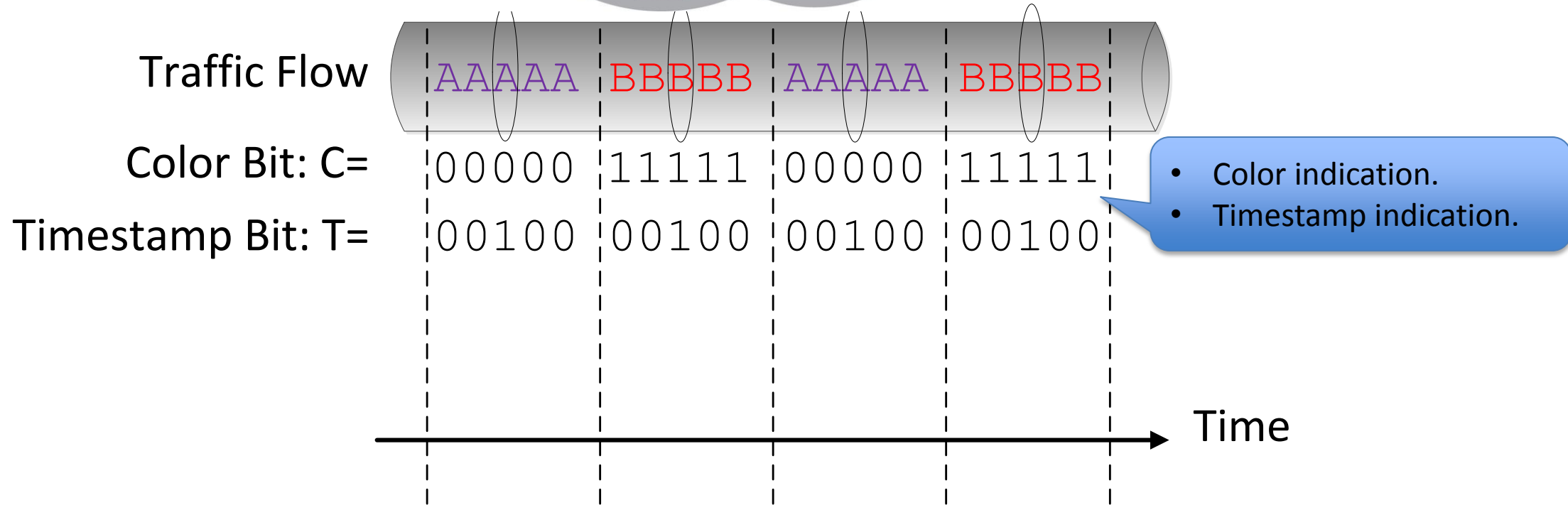
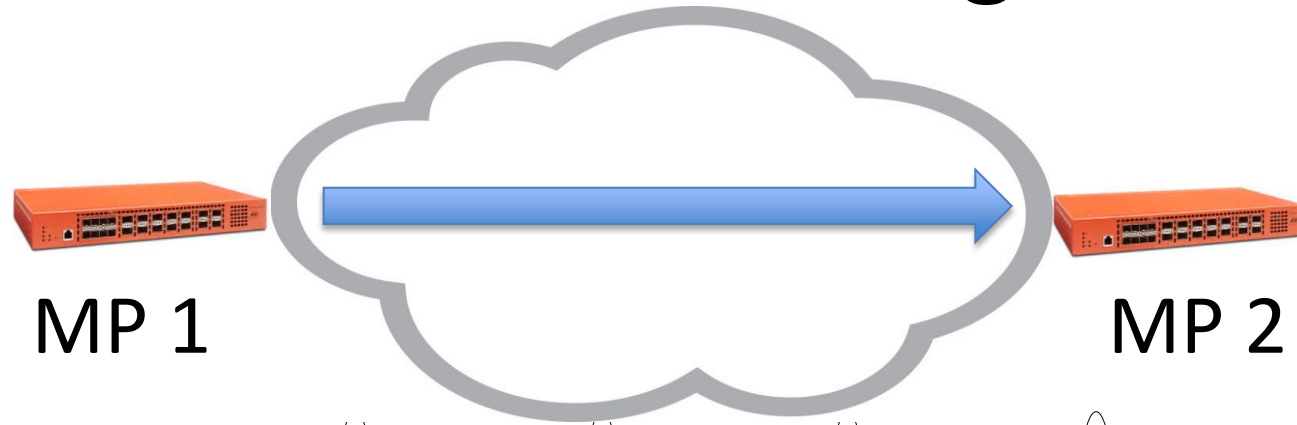

New Methods for Single-bit Marking

Method 3: Multiplexed Marking

- A single bit is used for C / T
- Same measurement resolution as double marking

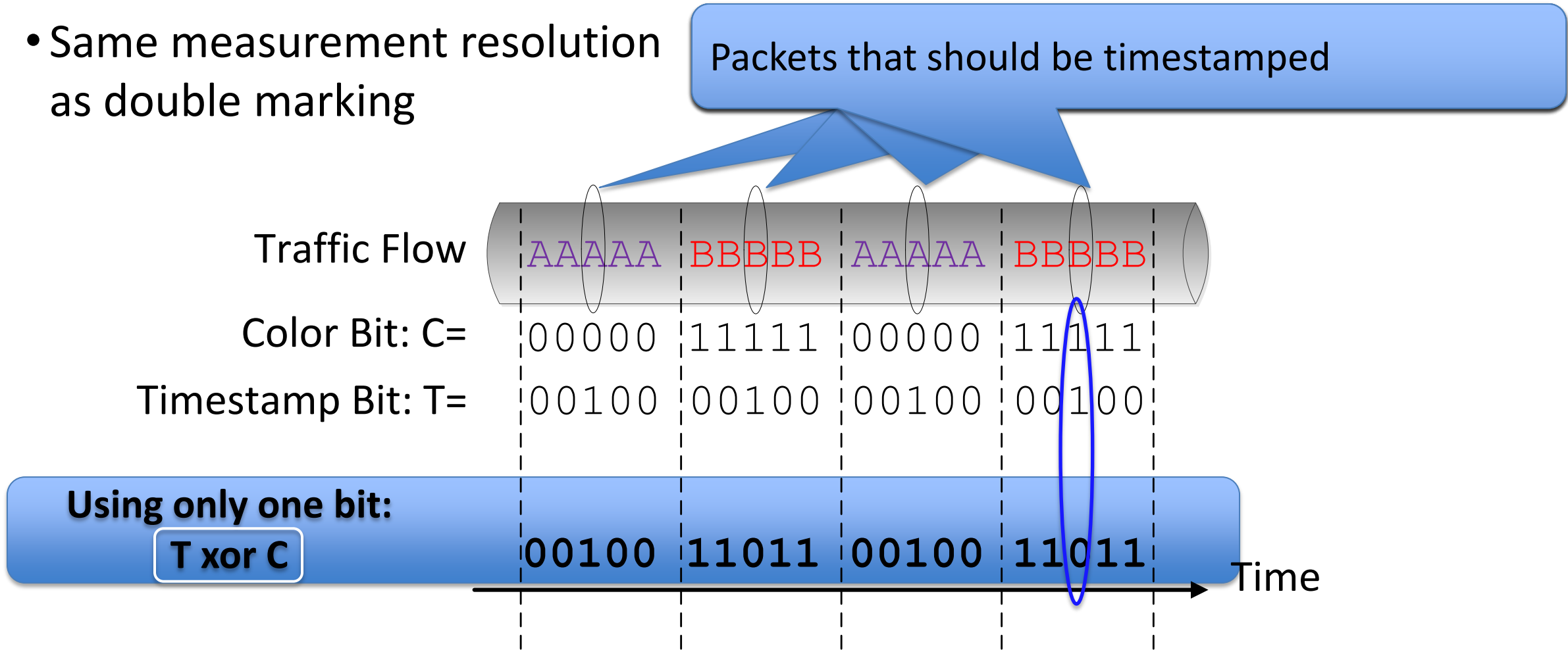

Method 4: Pulse Marking

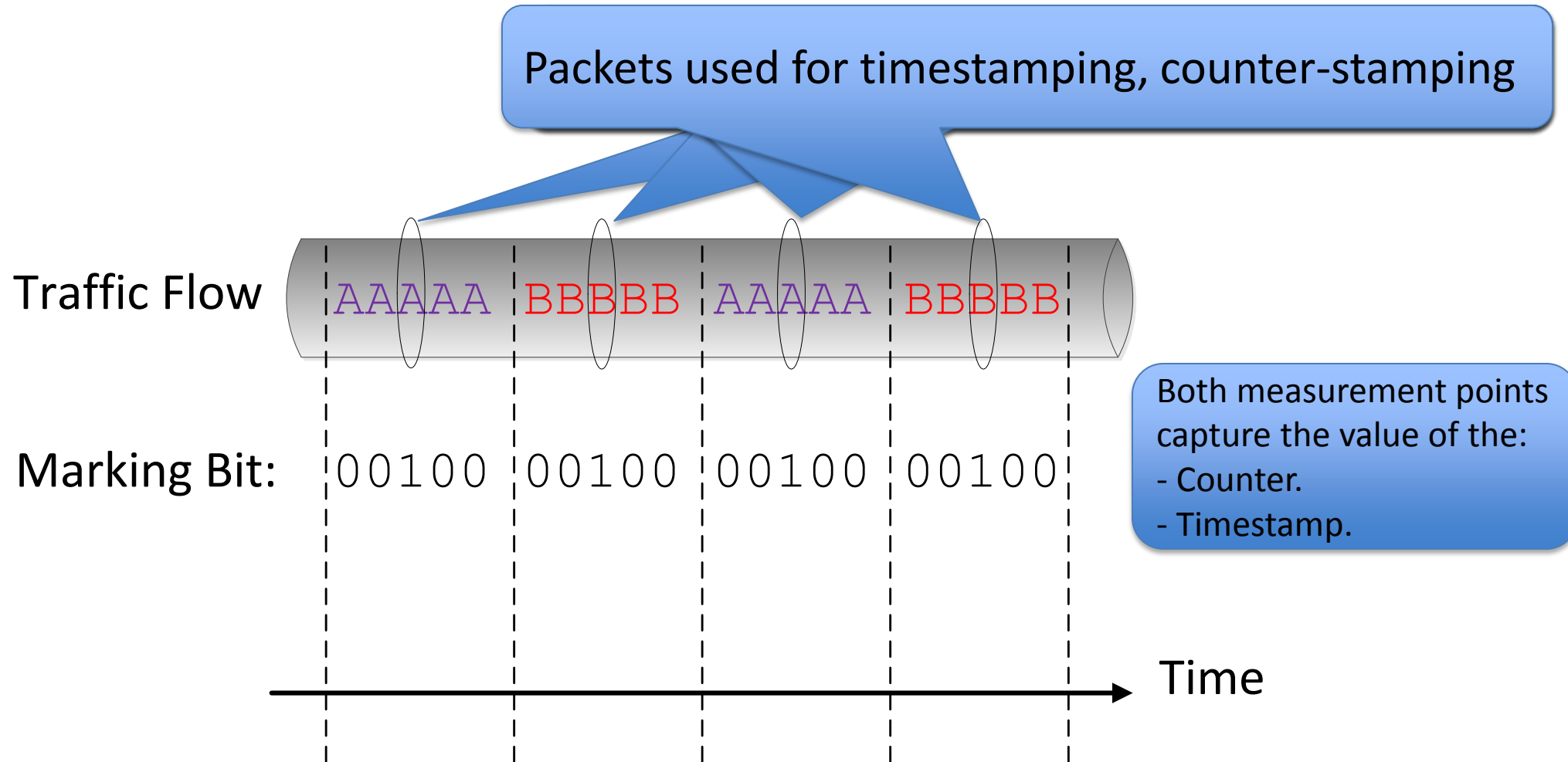

Methods for Zero-bit Marking

Hash-based Selection

- Hash is computed over packet header.
- If Hash = **SelectedValue**
Packet is selected for measurement

- It is possible to use a mixed approach:
 - Color bit
 - Hash-based sampling for delay measurement
 - Dynamic hash can be used to pace the number of samples per period

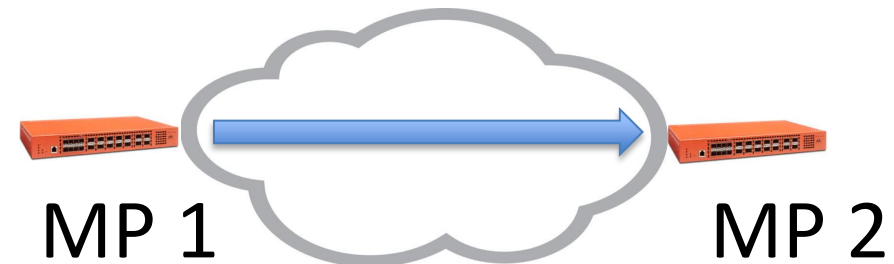

Summary

Summary and Tradeoff of Marking Methods

Method	# of bits	# of counters	LM Method	DM Method	Resilience to Reordering		Resilience to packet drops	
					LM	DM	LM	DM
Double marking	2	2	Step	Pulse	+	+	+	-
Single marking - 1st packet	1	2	Step	Step	+	--	+	--
Single marking - mean delay	1	2	Step	Mean	+	+	+	-
Multiplexed marking	1	2	Step	Pulse	+	+	+	-
Pulse marking	1	1	Pulse	Pulse	--	+	-	-
Hashed pulse marking	0	1	Hashed pulse	Hashed pulse	--	+	-	-
Hashed double marking	0	2	Hashed step*	Hashed pulse	+	+	+	-
Mixed hashed marking	1	2	Step	Hashed pulse	+	+	+	-

- + Accurate measurement.
- No measurement in case of disturbance (detectable).
- False measurement in case of disturbance (not detectable).
- * Hashed step works only when the hash is monotonically increasing.

IETF 99 Bits-n-Bites Alternate Marking Demo

- Alternate marking using one bit.
- Multiplexed marking approach.
- TimeFlips* are used for the color toggling.

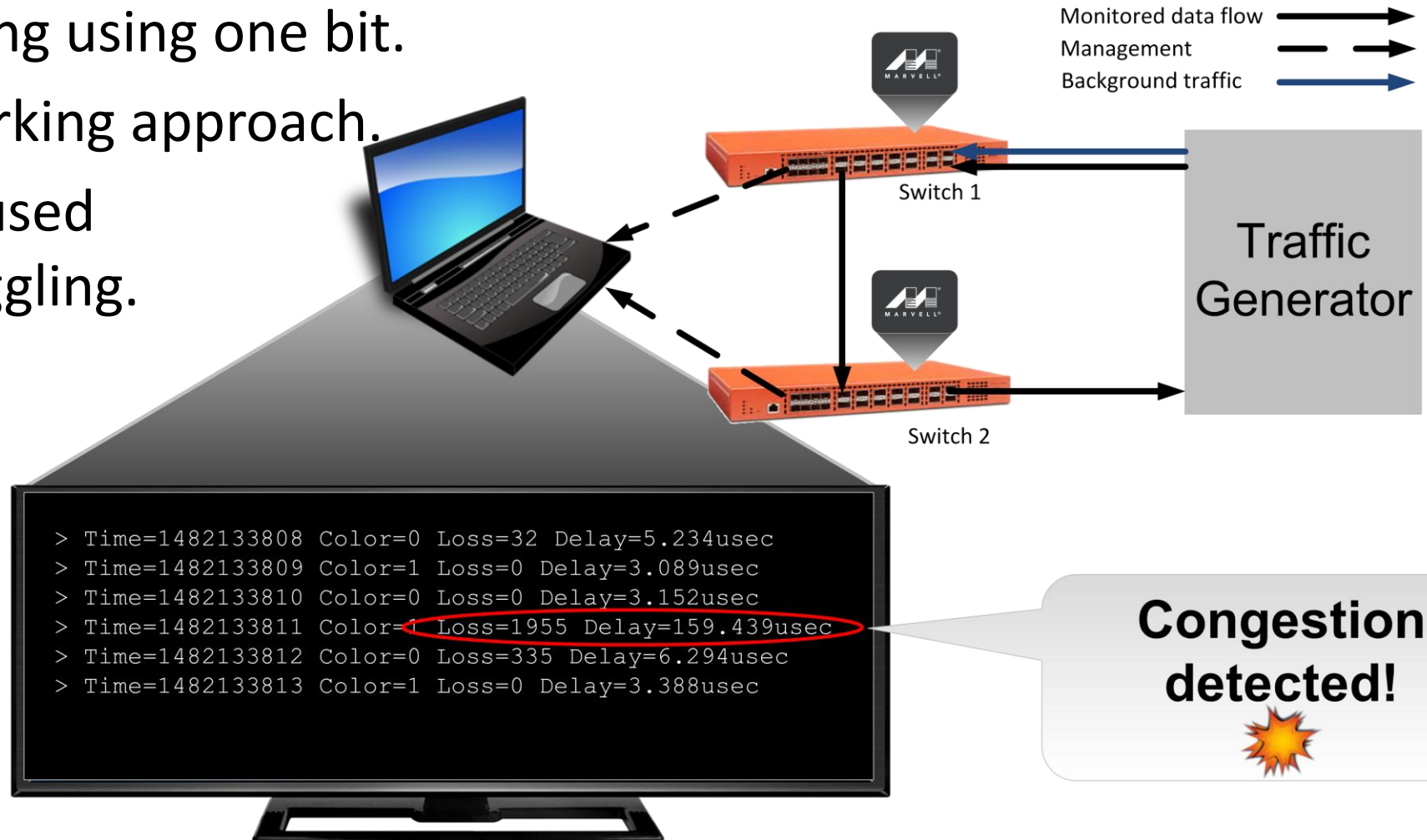

Draft History and Status

- October 2016 – first submission of draft-mizrahi-ippm-multiplexed-alternate-marking-00.
- Discussed at IETF 97, IETF 98.
- Draft 02 – major revision.
- October 2017 – renamed: draft-mizrahi-ippm-compact-alternate-marking-00

- Next step:
 - Ask for working group adoption.

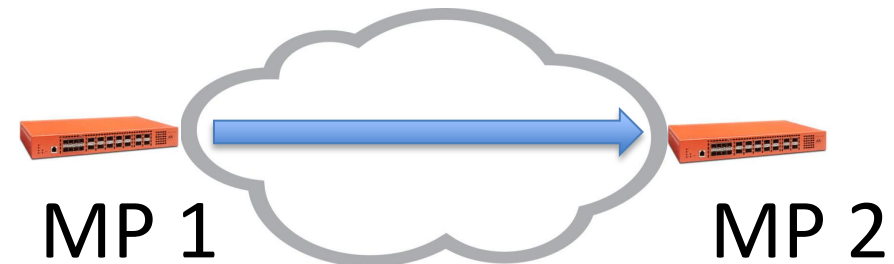

Thanks!

Method 1: Single Marking – 1st Packet

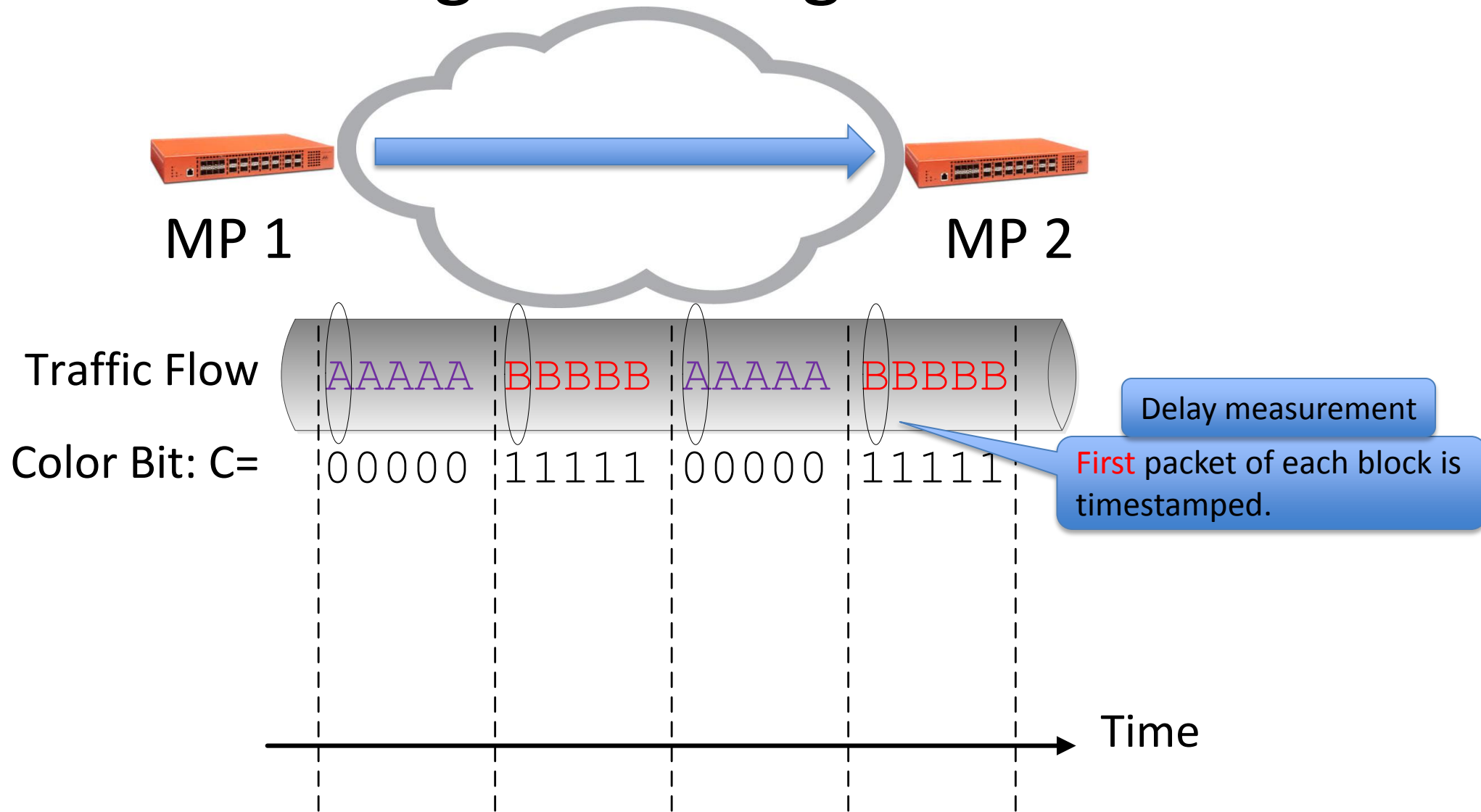

Method 2: Single Marking – Mean Delay

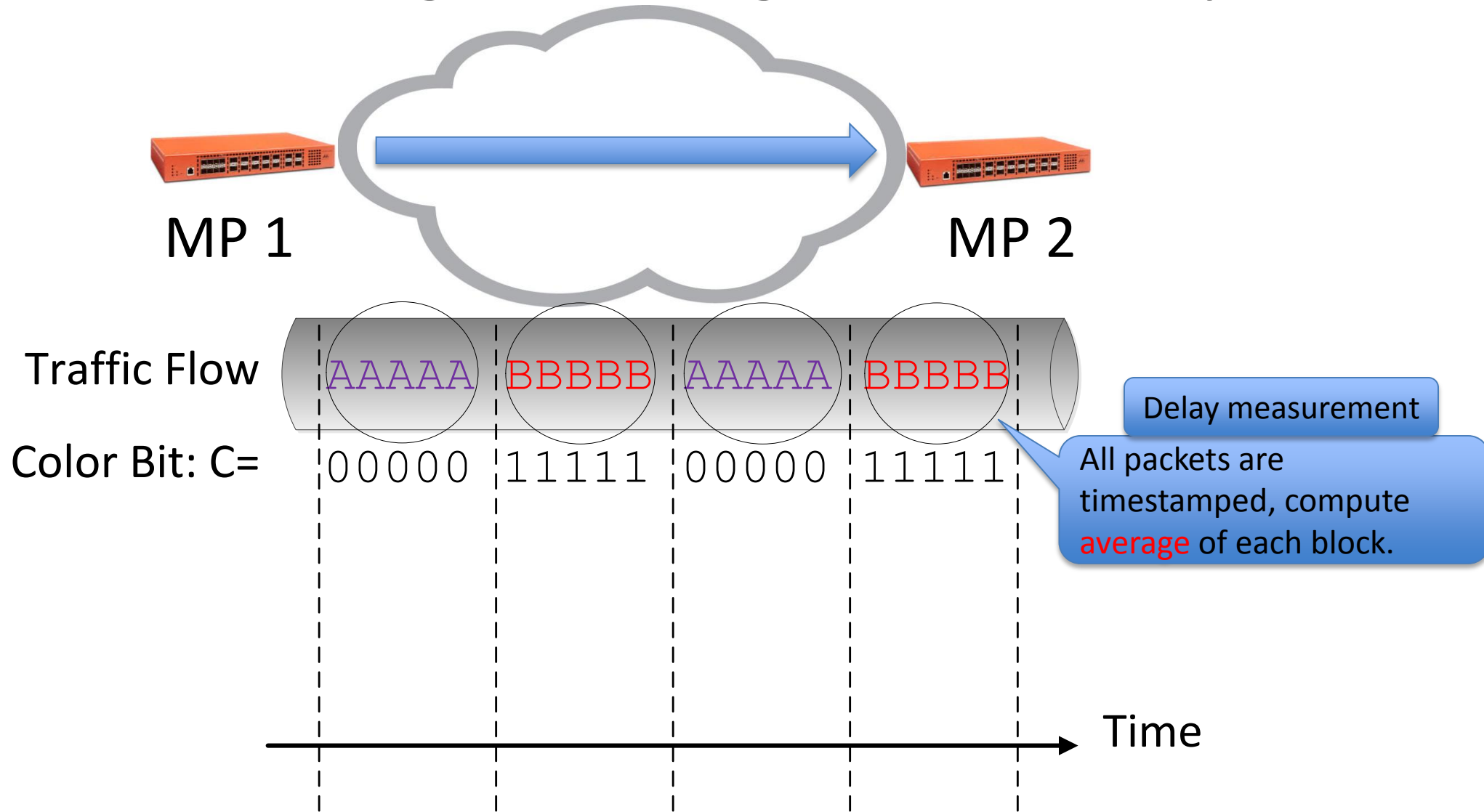

Multiplexed Marking using **Two Values**

Instead of a single marking bit → A marking field with **two values**: U, W.

E.g., two MPLS labels
[draft-bryant-mpls-rfc6374-sfl]

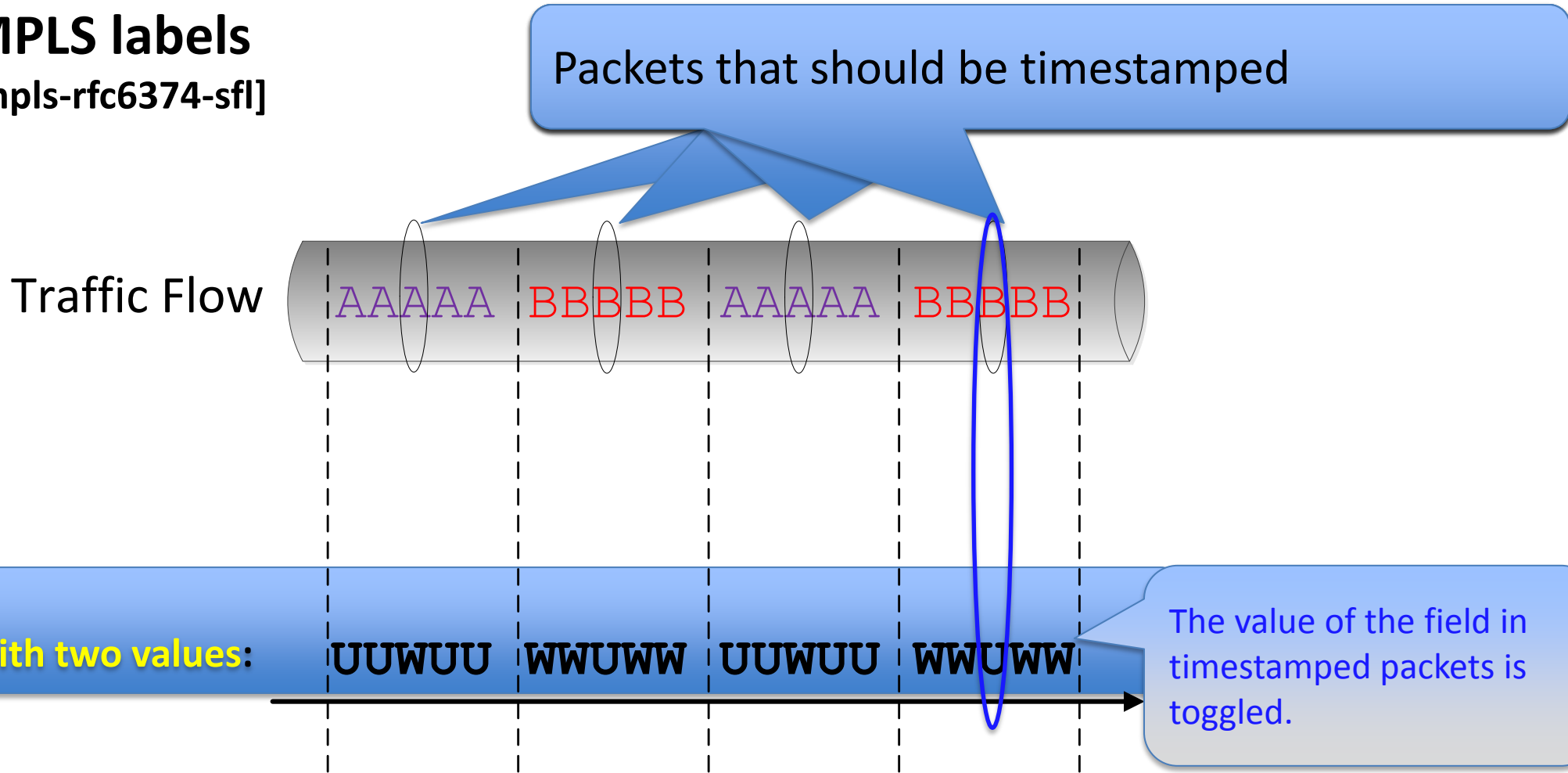

Related Work

- This presentation summarizes [1].
- The alternate marking method was first presented in [2], and later evolved into [3], [4]. Alternate marking using a conventional timestamp field is discussed in [5].
- The most updated version of the alternate marking working document is [3].
- Security considerations are discussed in [3] and in [1]. Security considerations of time protocols are discussed in [6].

References

- [1] T. Mizrahi, C. Arad, G. Fioccola, M. Cociglio, M. Chen, L. Zheng, G. Mirsky, "Compact Alternate Marking Methods for Passive Performance Monitoring", draft-mizrahi-ippm-compact-alternate-marking-00, work in progress, 2017.
- [2] M. Cociglio, A. Capello, A. Tempia Bonda, L. Castaldelli, "A packet-based method for passive performance monitoring", draft-tempia-opsawg-p3m-00, expired, 2011.
- [3] G. Fioccola, A. Capello, M. Cociglio, L. Castaldelli, M. Chen, L. Zheng, G. Mirsky, T. Mizrahi, "Alternate Marking method for passive performance monitoring", draft-ietf-ippm-alt-mark, work in progress, 2017.
- [4] M. Chen, L. Zheng, G. Mirsky, G. Fioccola, T. Mizrahi, "IP Flow Performance Measurement Framework," draft-chen-ippm-coloring-based-ipfpm-framework, expired, 2016.
- [5] T. Mizrahi, Y. Moses, "[The Case for Data Plane Timestamping in SDN](#)", IEEE INFOCOM Workshop on Software-Driven Flexible and Agile Networking (SWFAN), 2016.
- [6] T. Mizrahi, "Security Requirements of Time Protocols in Packet Switched Networks", RFC 7384, 2014.
- [7] S. Bryant, M. Chen, Z. Li, G. Swallow, S. Sivabalan, G. Mirsky, G. Fioccola, "RFC6374 Synonymous Flow Labels", draft-bryant-mpls-rfc6374-sfl (work in progress), 2016.
- [8] T. Mizrahi, O. Rottenstreich, Y. Moses, "[TimeFlip: Scheduling Network Updates with Timestamp-based TCAM Ranges](#)", IEEE INFOCOM, 2015.