

# A YANG Data Model for Microwave Topology

## draft-ye-ccamp-mw-topo-yang-00

M. YE , A.Guo(Huawei)

J. Ahlberg(Ericsson)

X. Li(NEC)

D. Spreafico(Nokia)

# Overview

- The draft defines a YANG data model to describe the topologies of microwave
- Augments the TE topology model
- Possible use cases:
  - 1) Resource management: the microwave link frequency could be used to understand the current frequency usage, enabling a whole view of the network topology information, and as an input for network frequency planning.
  - 2) Path computation: the microwave radio link could change its bandwidth according to the environments under the adaptive modulation mode, e.g., the bandwidth will degrade when there's a heavy rain.
    - To get to know of current microwave link bandwidth is important for path computation and service provisioning across different technologies/networks.
    - Due to bandwidth changing feature, availability is normally used to describe the microwave radio link characteristic. It's necessary to include the information in the YANG data model to optimize the path/route computation

# Microwave Topology YANG Tree

```
module: ietf-microwave-topology
```

```
augment /nw:networks/nw:network/nw:network-types/tet:te-topology:
```

```
  +--rw mw-topology!
```

```
augment /nw:networks/nw:network/nt:link/tet:te/tet:te-link-attributes:
```

```
  +--rw mw-link-frequency?          uint32
```

```
  +--rw mw-link-channel-separation? uint32
```

```
  +--ro mw-link-nominal-bandwidth?  rt-types:bandwidth-ieee-float32
```

```
  +--ro mw-link-current-bandwidth?  rt-types:bandwidth-ieee-float32
```

```
  +--ro mw-link-availability*
```

```
    +--ro mw-link-availability      rt-types:percentage
```

```
    +--ro mw-link-bandwidth          rt-types:bandwidth-ieee-float32
```

# How is the topology model related with interface model

- The topology model defines in this draft is a Network Service YANG Module, that is expected to be used between a PNC and a MDSC.
- [I-D.ietf-ccamp-mw-yang] defines an interface YANG model for microwave radio link. It's a Network Element YANG module that is used between the PNC and the physical device for device configuration.
- The PNC is able to convert the information received from the topology model into the interface model. For example, the link frequency in the topology model is mapped to the tx-frequency of the carrier termination in the interface model.
- It's also explained in RFC8199, Layering of modules allows for reusability of existing lower-layer modules by higher-level modules while limiting duplication of features across layers.

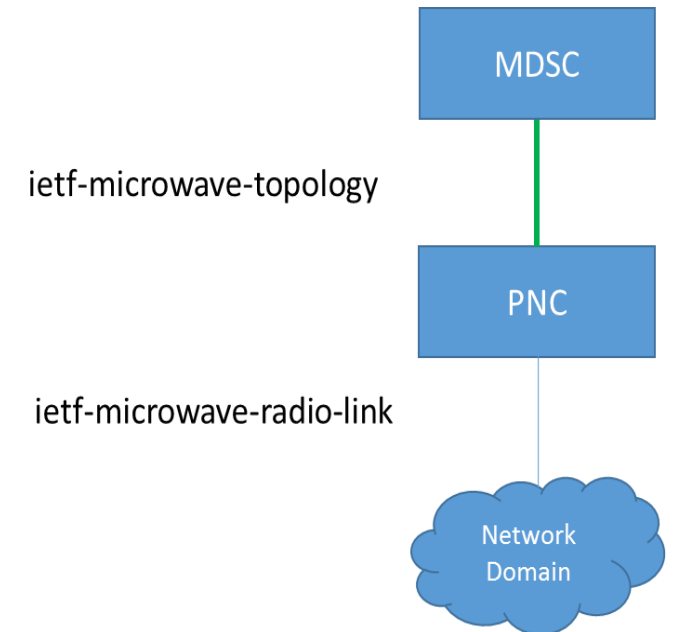

# Example 1- single mw link

**TE Topology - Eth**

```

"ietf-network-topology:link": [
  {
    "link-id": "N1,LTP11,N2,LTP21",
    "source": {
      "source-node": "N1",
      "source-tp": "LTP11"
    }
  }
]

"ietf-te-topology:link/te/te-link-attributes/underlay": [
  {
    "enabled": true,
    "primary-path": {
      "path-element": {
        "path-element-id": "MW-11"
        //no backup-path
        //no protection-type
      }
    }
  }
]

"tunnel-termination-points": {
  "source": "N1/TTP-1",
  "destination": "N2/TTP-1"
}

"tunnels": {
  "sharing": "false",
  "tunnel": {
    "tunnel-name": "MW-11",
    "sharing": "false"
  }
}

```

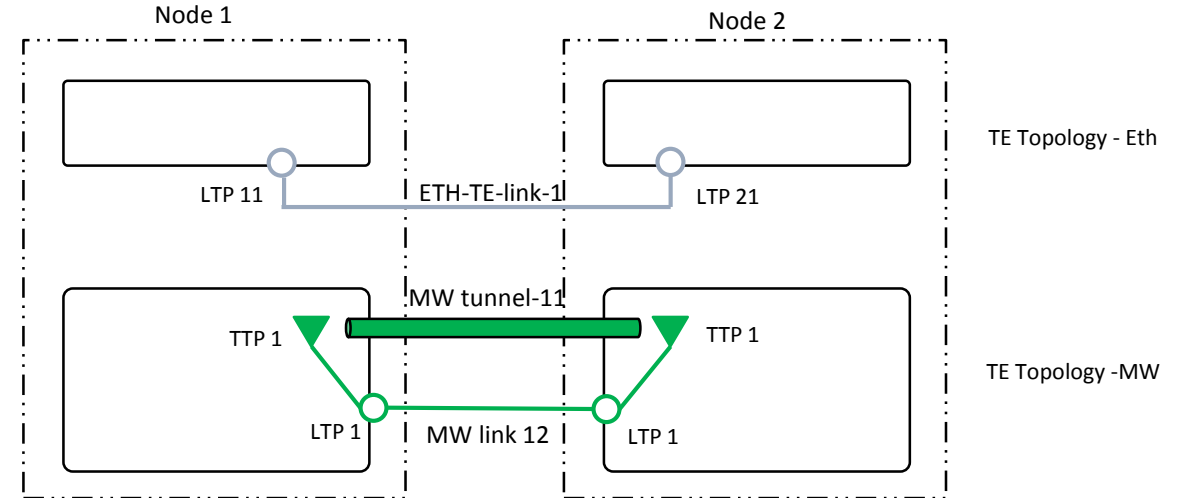

**TE Topology - MW**

```

"ietf-network-topology:link": [
  {
    "link-id": "N1,LTP1,N2,LTP1",
    "source": {
      "source-node": "N1",
      "source-tp": "LTP1"
    }
  }
]

"ietf-te-topology:link/te/te-link-attributes": [
  {
    "mw-link-frequency": 10728000,
    "mw-link-channel-separation": "28000",
    "mw-link-actual-tx-cm": "qam-512",
    "mw-link-nominal-bandwidth": "1000",
    "mw-link-current-bandwidth": "1000",
    "mw-link-availability": {
      "mw-link-availability": "0.9999",
      "mw-link-bandwidth": "1000"
    }
  }
]

```

# Example 2- mw links bundling

## TE Topology - MW

```

"ietf-network-topology:link": [
  {
    "link-id": "N1,LTP1,N2,LTP1",
    "source": {
      "source-node": "N1",
      "source-tp": "LTP3"
    }
    "destination": {
      "dest-node": "N2",
      "dest-tp": "LTP3"
    }
  }
]

"ietf-te-topology:link/te/te-link-config": [
  {
    "bundle-stack-level": {
      "component": {
        "component-links-1": {
          "sequence": "mw-11",
          "src-tp-ref": "N1-LTP1",
          "des-tp-ref": "N2-LTP1"
        }
        "component-links-2": {
          "sequence": "mw-22",
          "src-tp-ref": "N1-LTP2",
          "des-tp-ref": "N2-LTP2"
        }
      }
    }
  }
]

```

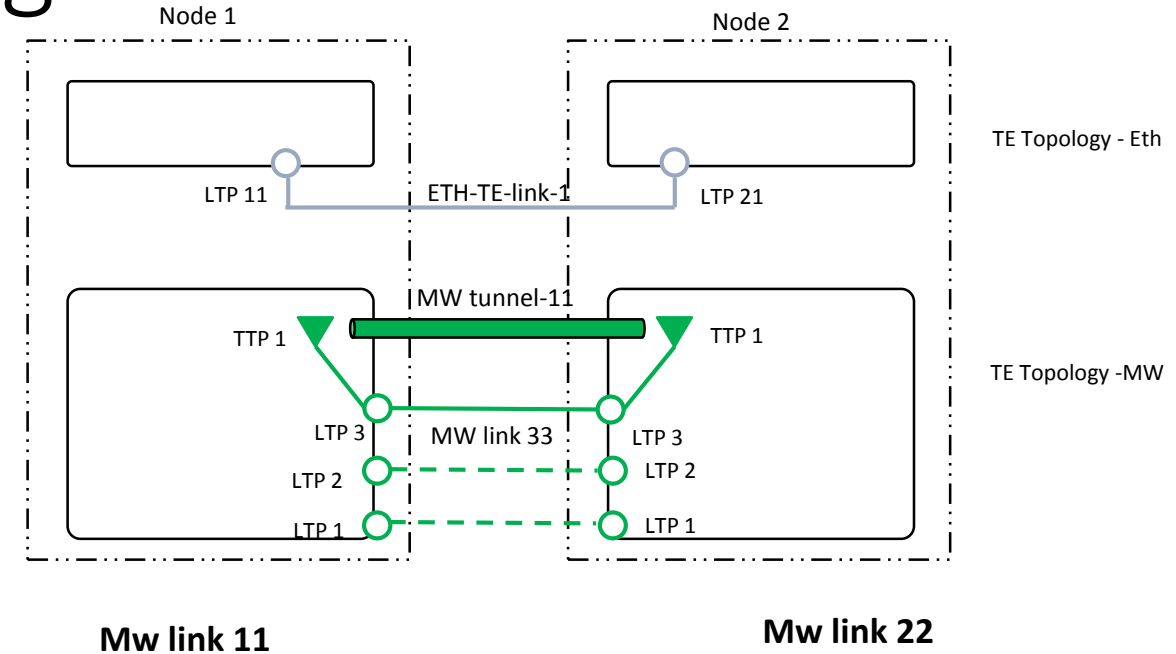

Mw link 11

Mw link 22

```

"ietf-te-topology:link/te/te-link-attributes": [
  {
    "mw-link-frequency": 10728000,
    "mw-link-channel-separation": "28000",
    "mw-link-actual-tx-cm": "qam-512",
    "mw-link-nominal-bandwidth": "1000",
    "mw-link-current-bandwidth": "1000",
    "mw-link-availability": {
      "mw-link-availability": "0.9999",
      "mw-link-bandwidth": "1000"
    }
  }
]

```

```

"ietf-te-topology:link/te/te-link-attributes": [
  {
    "mw-link-frequency": 10618000,
    "mw-link-channel-separation": "28000",
    "mw-link-actual-tx-cm": "qam-512",
    "mw-link-nominal-bandwidth": "1000",
    "mw-link-current-bandwidth": "1000",
    "mw-link-availability": {
      "mw-link-availability": "0.9999",
      "mw-link-bandwidth": "1000"
    }
  }
]

```

- There was suggestion that the two microwave component links should not be seen in mw-topo.
- Then how to see the component links details?

# Next steps

- Received offline comments to complete the example in the appendix
- A microwave SDN plugtest is planned in ETSI mWT. The microwave topology model will be verified in the plugtest. Further updated on the model is expected.
- It's proposed to use the draft as a starting point to define the microwave topology YANG model, would like to ask for WG adoption
- Side discussion during this week, welcome to join