

5G User Mobility Network

draft-herbert-ila-mobile-01.txt

IETF 101 London

17th – 23rd March, 2018

T. Herbert, K. Bogineni

Acknowledgements

Thanks to several Verizon members Gerry Libunao, Jay Lee, Yee Sin Chan and Sudhakar Patil for explaining the 3GPP 5G specifications and to Nirranjan Avula, Ratul Guha, and Jignesh Panchal for discussions and development of architecture options for the 5G System using ILA.

Overview

- User Mobility Use Case Description
- Why ILA?
- 5GC Protocol Stack with ILA
- ILA in 5G Architecture
- Anchor-less Mobility
- Recommendation

Use Case Description

3GPP Release 15 NGC Architecture

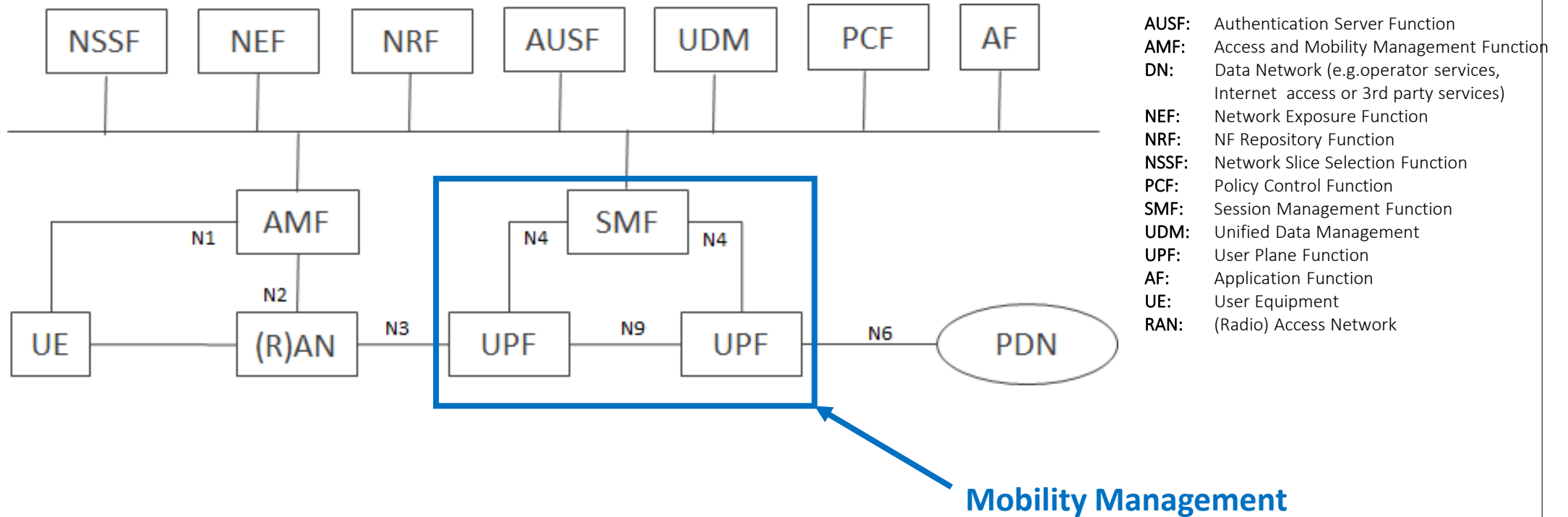

Why ILA?

- 'Zero' Tunneling/encapsulation overhead
 - Eliminated (more prominent for small packet sizes e.g. IOT)
 - Reduced backhaul capacity requirements (important when large numbers of 5G cell sites become operational)
- Anchor-less Mobility
 - Simplifies network
 - Reduces state information
- Support for low latency applications
 - Reduced packet processing
 - No additional network functions needed at network edge

5G Protocol Stack with ILA

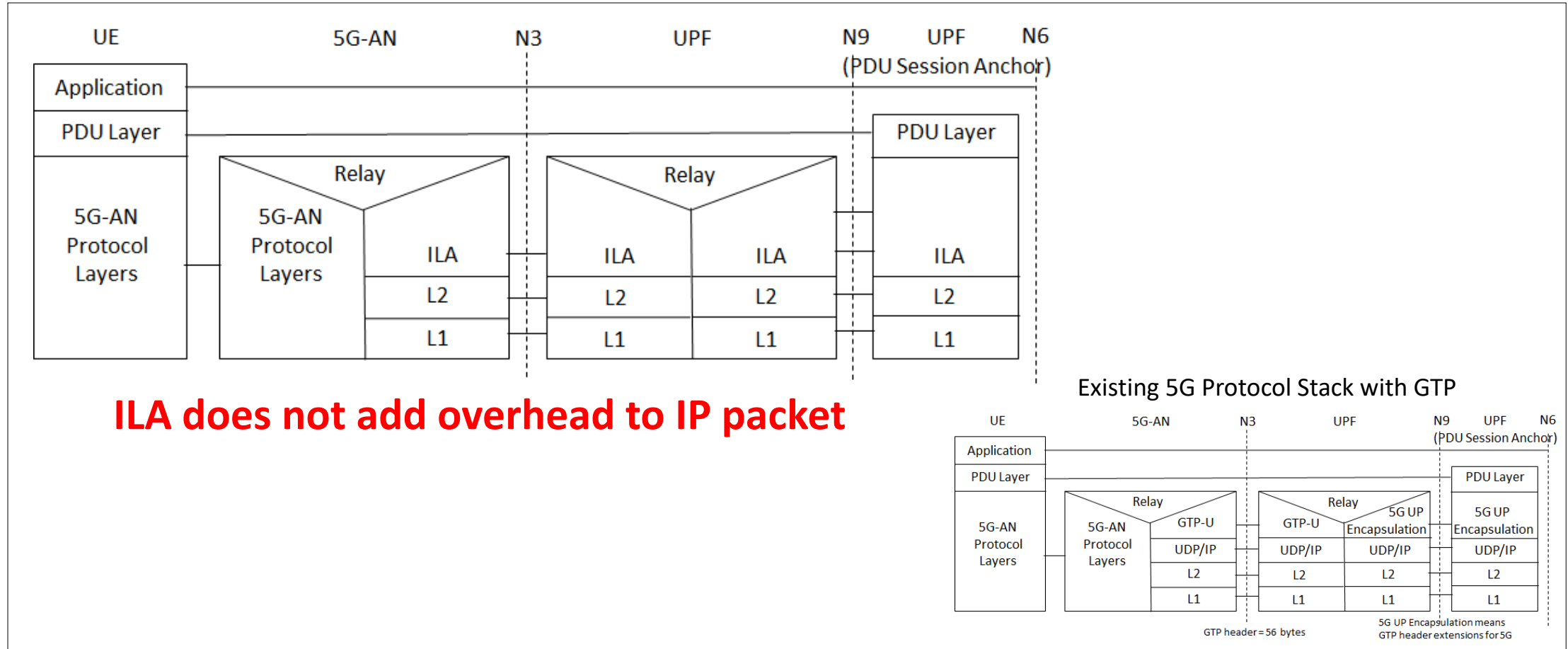

Proposed Architecture for ILA in Release 16

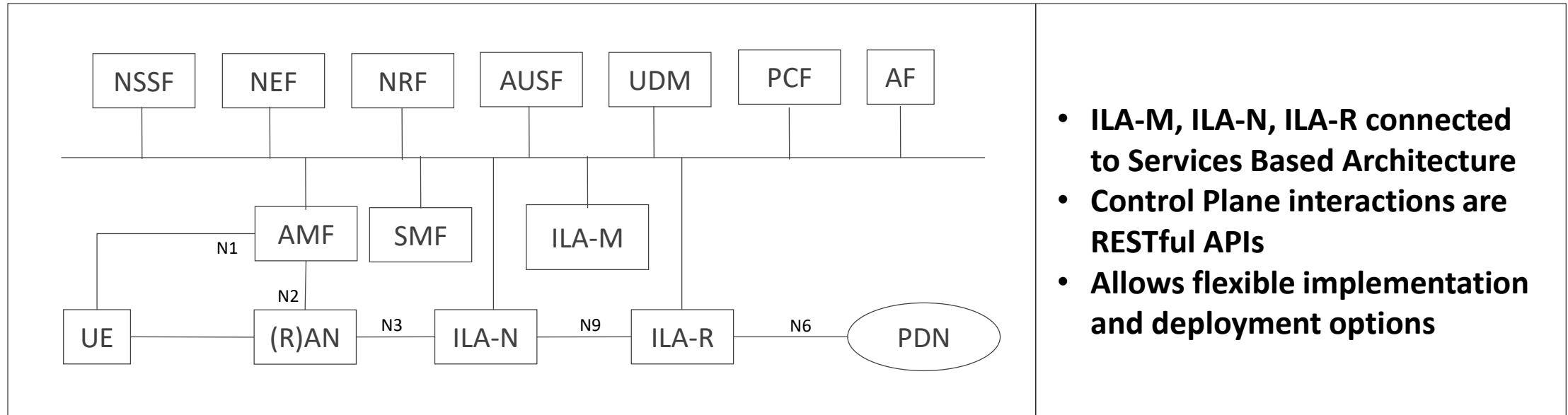

- **ILA-M, ILA-N, ILA-R connected to Services Based Architecture**
- **Control Plane interactions are RESTful APIs**
- **Allows flexible implementation and deployment options**

- **Roaming:** Existing roaming principles can be re-used
- **Security/Privacy:** Re-use of same principles as today's mobile operator network
- **Scalability (mapping system, control plane signaling):** Network design aspects from 4G networks (MME-eNB, SGW-eNB, X2, etc) will be used to develop solutions using ILA

Anchor-less Mobility

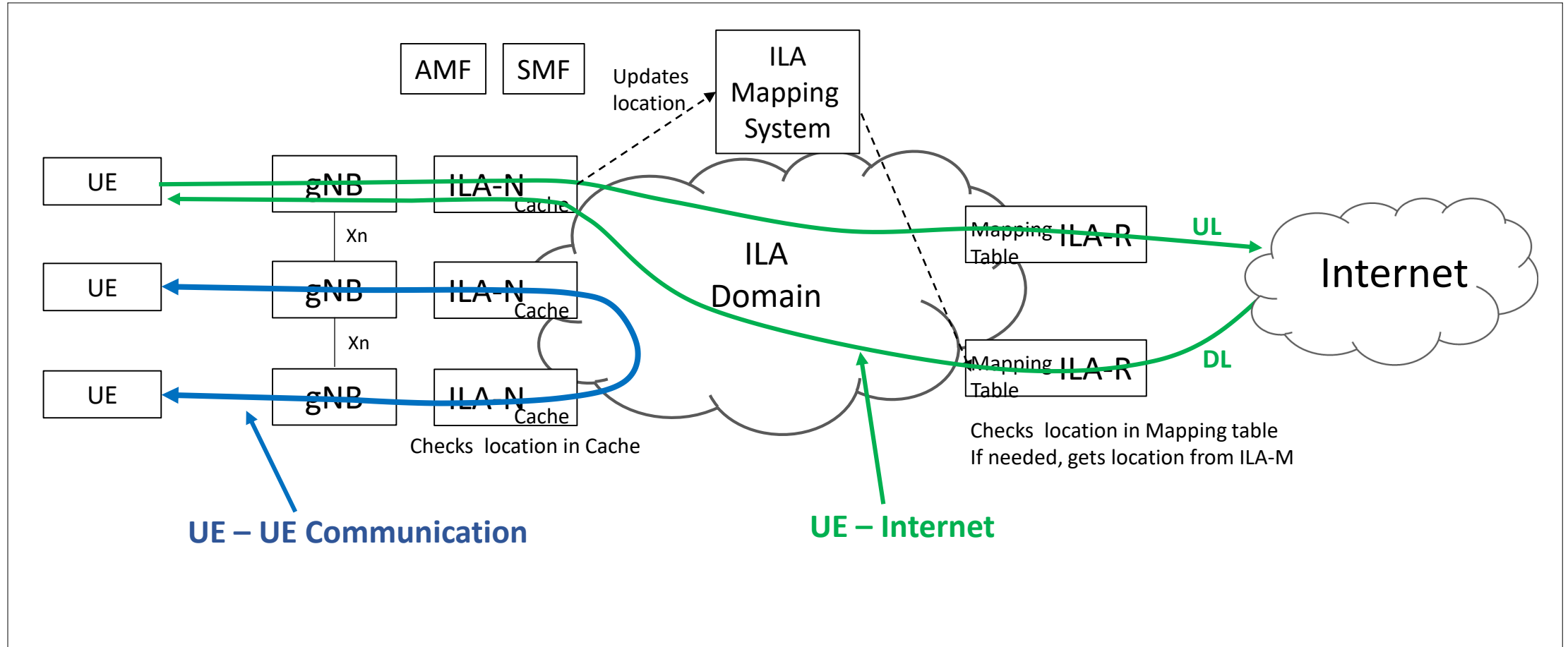

Recommendation

- Develop ILA Specifications in a phased approach
- Focus on Mobility Use Case initially
- Deliverables: ILA core protocol, reference control plane protocol, and architecture considerations for user mobility use case