

Node protection for RSVP-TE tunnels on a shared MPLS forwarding plane

draft-chandra-mpls-rsvp-shared-labels-np-00

Chandra Ramachandran (csekar@juniper.net)

Vishnu Pavan Beeram (vbeeram@juniper.net)

Harish Sitaraman (hsitaraman@juniper.net)

Motivation

- With the procedures specified in [draft-ietf-mpls-rsvp-shared-labels], a shared MPLS forwarding plane can be realized by allowing the TE link label to be shared by LSPs traversing the link.
 - Includes guidelines for providing facility backup link protection at a PLR.
- This draft proposes guidelines for providing facility backup node protection at a PLR for Segment Routed RSVP-TE tunnels.

Node Protection

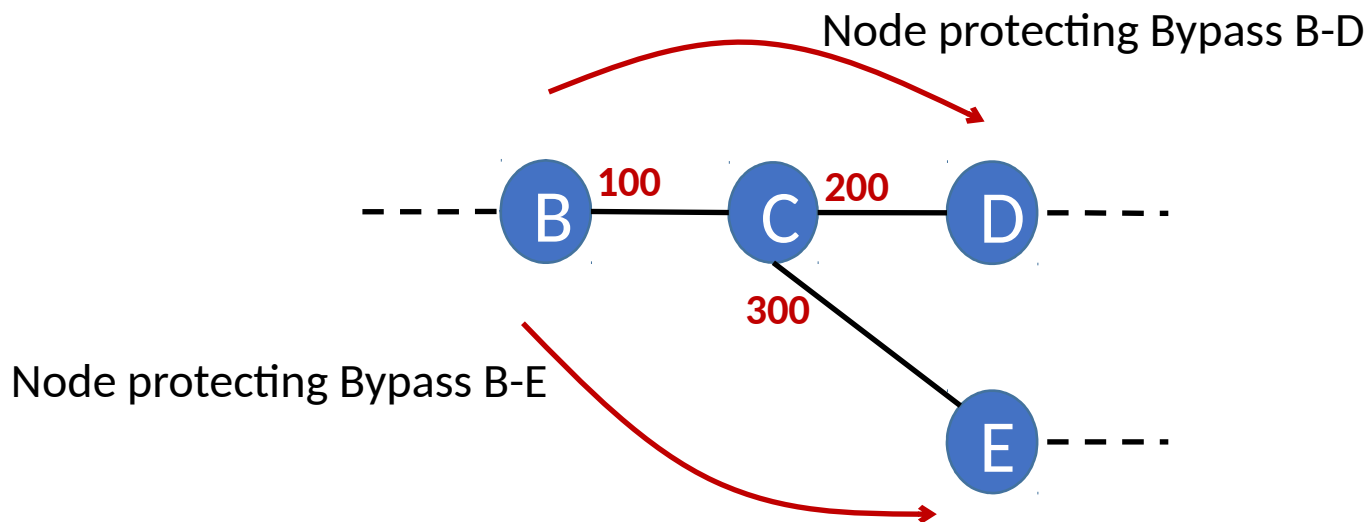

At PLR B:

- Different node protecting bypass depending on next-next-hop LSR (MP)
- Cannot use the same TE link label for B-C for LSPs unless next-next-hop LSR is also shared

PLR Procedures for protecting Next-Hop Non-Delegation LSR

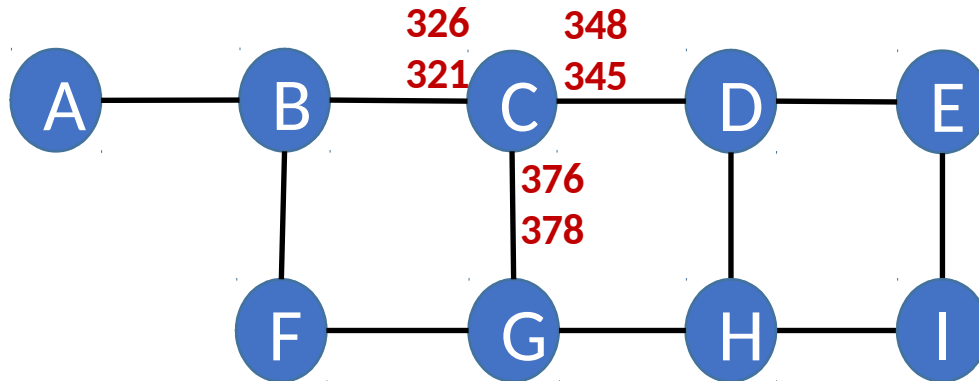

At LSR C, allocate:

- 321 for the TE link C-B to reach the next-next-hop LSR A
- 326 for the TE link C-B to reach the next-next-hop LSR F
- 345 for the TE link C-D to reach the next-next-hop LSR E
- 348 for the TE link C-D to reach the next-next-hop LSR H etc.

Forwarding actions at PLR C:

- Pop the TE link label and forward the packet to the next-hop LSR
- Pop the TE link label and the label beneath it and forward the packet over the node protecting bypass tunnel to the next-next-hop LSR (Merge Point).

PLR Procedures for protecting Next-Hop Delegation LSR

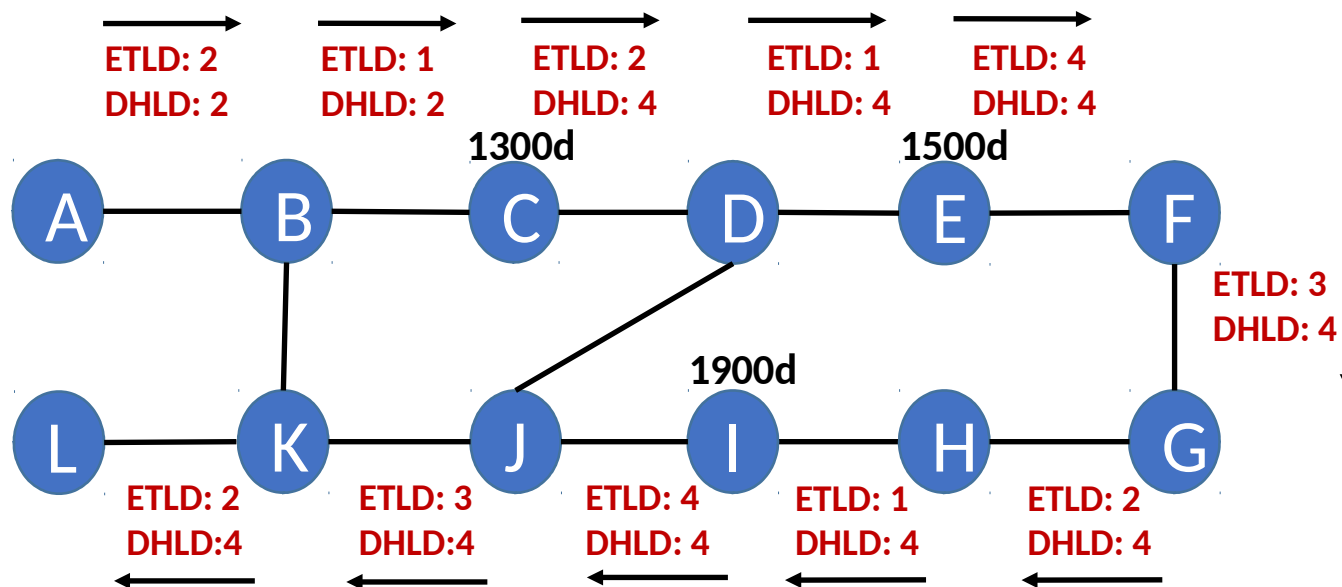

ETLD at LSR C = MIN(computed ETLD = 4, previous hop DHLD = 2).

Forwarding actions at PLR B:

- Pop the TE link label and forward the packet to the next-hop LSR C
- Pop the TE link label and the label beneath it and push the label stack on behalf of the next hop delegation LSR C and forwards the packet over the node protecting bypass tunnel to the next-next-hop LSR D (Merge Point).

Backwards Compatibility

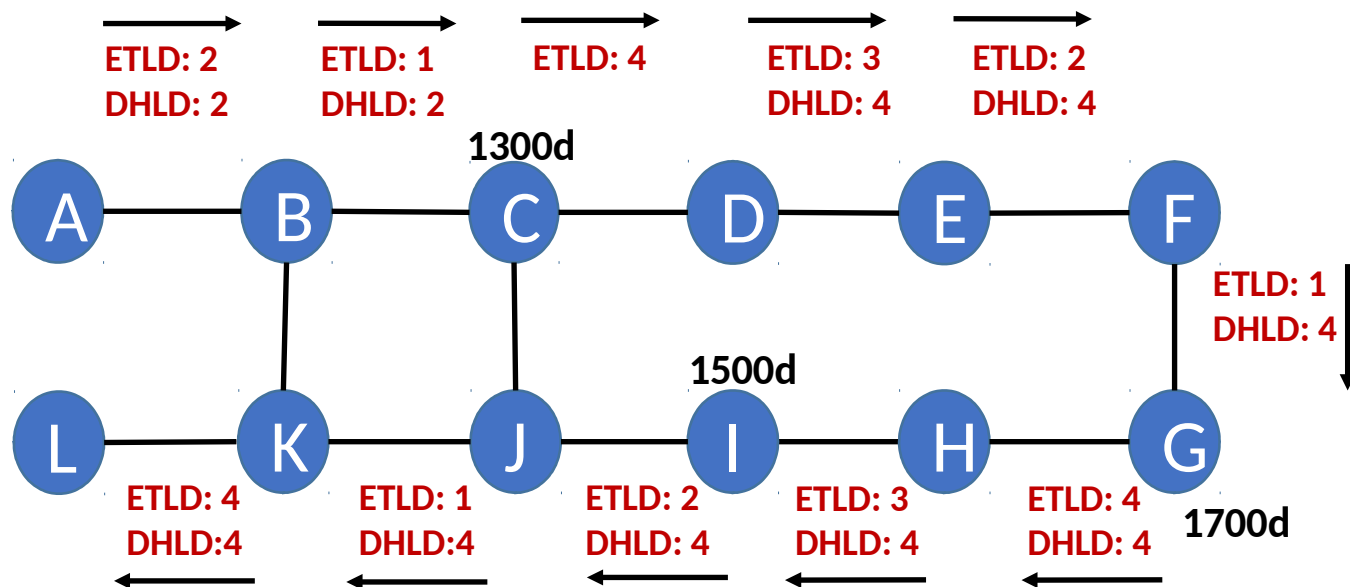

- Delegation hop C does not support the DHLD extensions and hence sets ETLD normally.
- B cannot push the entire label stack that C would push as a delegation hop. Instead, B can offer link protection.

Next Steps

- Request WG feedback