

SR Path Segment & Bidirectional Path in PCEP

draft-li-pce-sr-path-segment-03
draft-li-pce-sr-bidir-path-02

Cheng Li/Mach Chen/Dhruv Dhoby/Weiqiang Chen/Rakesh

Jie Dong/Zhenbin Li

IETF#103

Motivation

- Use cases like end-2-end 1+1 path protection, bidirectional path correlation or performance measurement (PM) require the ability to implement “path identification” in SR networks:
 - [\[draft-cheng-spring-mpls-path-segment\]](#) introduces a new segment to uniquely identify an SR path in a specific context that is referred to as Path Segment.
 - [\[draft-li-spring-srv6-path-segment\]](#) defines a Path Segment in SRv6.
- For configuring or allocating Path Segment to an SR path, extensions in PCEP are needed.
 - Path Segment allocation and conveying it within PCEP
 - PCE controlled ID Space, where PCC informs the PCE the ID space range from which it should make allocations
- Bidirectional path correlation is required in some scenarios such as mobile backhaul transport network for Segment Routing.
 - Path Segment can be used for binding

Updated Drafts

- **draft-li-pce-sr-path-segment-03**

- Specifies extensions to the PCEP to support path identifier allocation between PCEP speakers.
- PATH-SEGMENT TLV in the LSP object
- P-flag in LSP object
- P-flag in SR/SRv6 Capabilities TLVs

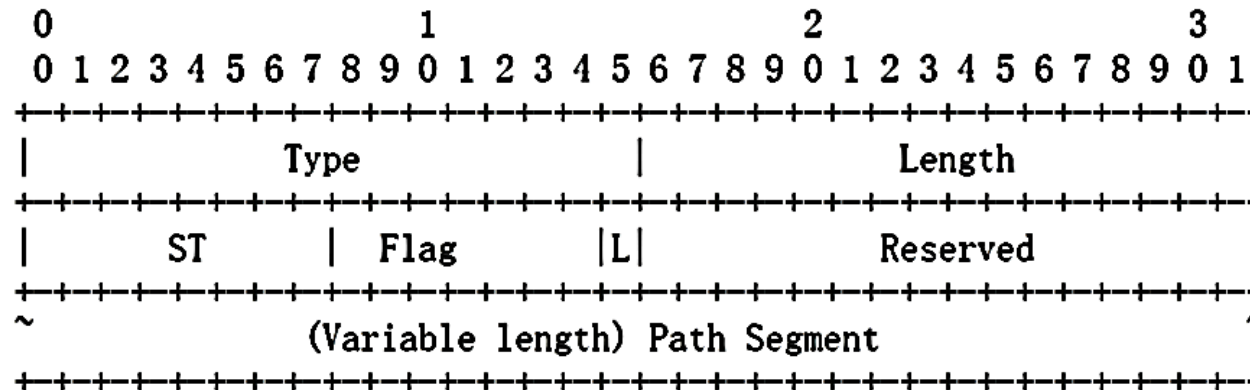

- **draft-li-pce-sr-bidir-path-02**

- Defines PCEP extensions for grouping two reverse unidirectional SR Paths into an Associated Bidirectional SR path
- Defines “Double-sided Bidirectional SR Path Association Group” Object

PCEP Extension for Path Identification in SR

Updates: draft-li-pce-sr-path-segment-03

- Update
 - Path ID -> Path Segment in SRv6(draft-li-spring-srv6-path-segment)
- Delete
 - Ingress allocation mechanisms.(Sync up with draft-cheng-spring-mpls-path-segment-03)
 - Two labels solution
- Add
 - New authors and contributors: Weiqiang Cheng(CMCC), Rakesh, Zafar(Cisco),
 - IANA Considerations
 - Data plane Considerations
 - Error Handling
- Implementation Status:
 - Huawei: implementing in PCE and PCC products.

PCEP Extension for SR Bidirectional Associated Paths

Updates: draft-li-pce-sr-bidir-path-02

- Update
 - Path ID -> Path Segment in SRv6(draft-li-spring-srv6-path-segment)
- Delete
 - Stateless PCE
- Add
 - New authors and contributors: Weiqiang Cheng(CMCC), Rakesh(Cisco),
 - IANA Considerations
 - Security Considerations
 - Error Handling
- Implementation Status:
 - Huawei: implementing in PCE and PCC products.

Ready for WG Adoption

- The drafts are ready for WG adoption
 - Context of the drafts are stable
 - Commercial implementation is going on
 - Supported by operators and vendors
 - Request for early IANA allocation
- We would like to post WG adoption requests for drafts
 - [draft-li-pce-sr-path-segment-03](#)
 - [draft-li-pce-sr-bidir-path-02](#)
- Your comments and contributions are very welcome!

Thank you

CHENG LI

Path Segment/ID in PCEP

draft-li-pce-controlled-id-space-00

draft-li-pce-sr-path-segment-00

draft-li-pce-sr-bidir-path-00

Cheng Li/Mach Chen/Dhruv/Lizhenbin

IETF#102

Motivation

- Use cases like end-2-end 1+1 path protection, bidirectional path correlation or performance measurement(PM) require the ability to implement path identification in SR networks:
 - [draft-cheng-spring-mpls-path-segment](#) introduces a new segment to uniquely identify an SR path in a specific context that is referred to as Path Segment.
 - [draft-li-spring-passive-pm-for-srv6-np](#) defines a Path ID to identify an SRv6 path.
- For configuring or allocating path ID to an SR path, extensions in PCEP are needed.
 - PCE controlled ID Space distribution.
 - Path Segment allocation.
- Bidirectional path correlation is required in some scenarios such as mobile backhaul transport network.
 - Bidirectional path correlation based on path Segment/ID.

Drafts

- **draft-li-pce-controlled-id-space-00**
 - specifies a mechanism for a PCC to inform the PCE of the identifier space under its control via PCEP.
- **draft-li-pce-sr-path-segment-00**
 - specifies extensions to the PCEP to support path identifier between PCEP speakers.
- **draft-li-pce-sr-bidir-path-00**
 - defines PCEP extensions for grouping two reverse unidirectional SR Paths into an Associated Bidirectional SR path

draft-li-pce-controlled-id-space-00

- [I-D.zhao-pce-pcep-extension-for-pce-controller](#) specifies the procedures and PCEP protocol extensions for using the PCE as the central controller, where label forwarding entries are downloaded through extending PCEP.
- [I-D.zhao-pce-pcep-extension-for-pce-controller-sr](#) specifies the procedures and PCEP protocol extensions for using the PCE as the central controller in SR networks.
- However, these documents assume that label range to be used by a PCE is known and set on both PCEP peers.
- This document specifies the extension to support advertisement of the various ID space to the PCE to control.

draft-li-pce-controlled-id-space-00

- For delegating ID space, related ID Space TLV MUST be included in the Open message.
- Each TLV (corresponding to each ID type) SHOULD be included only once in a Open Message.
- The following ID-CONTROL-SPACE TLVs are defined in this document –
 - LABEL-CONTROL-SPACE - for MPLS Labels
 - SRv6-PATH-ID-CONTROL-SPACE - for SRv6 Path ID

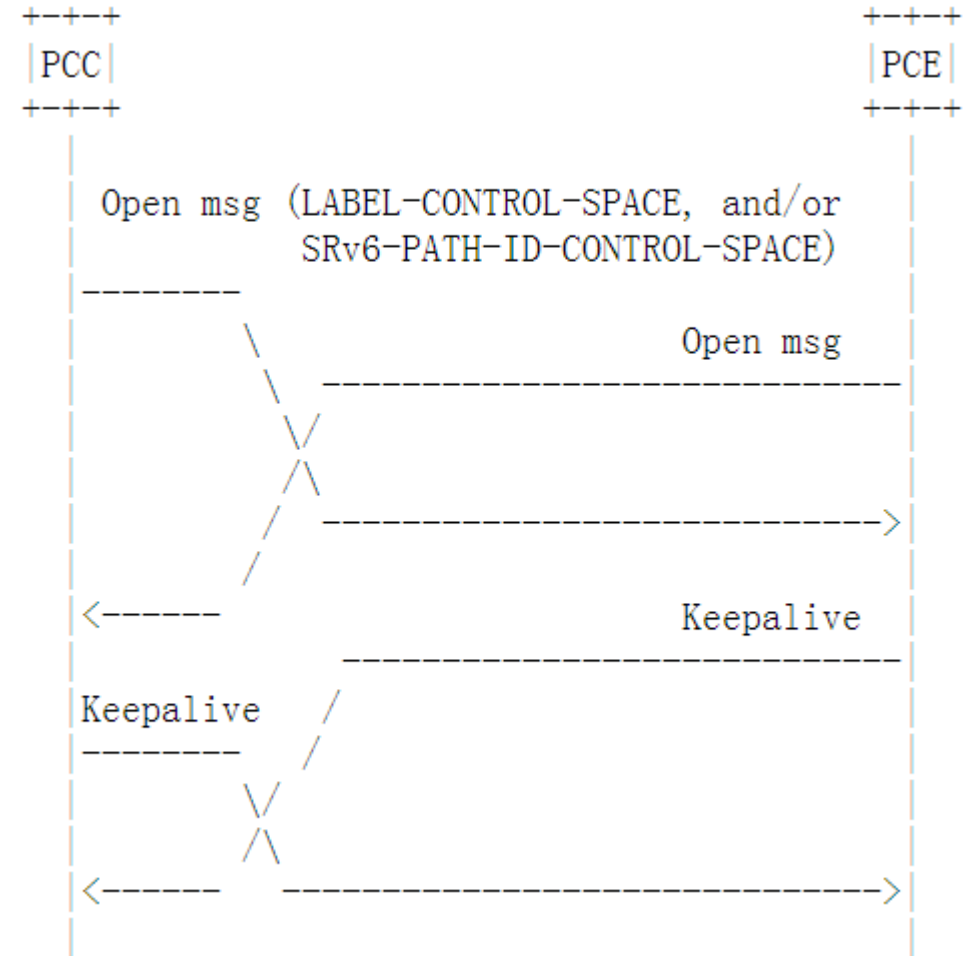

LABEL-CONTROL-SPACE TLV

- Flags:
 - A: All space flag, set when all the label space is delegated to a PCE.
- Blocks
 - Start(i) (24 bits): indicates the beginning of the label block i.
 - Range(i) (24 bits): indicates the range of the label block i.
- Labels:
 - such as binding SID and path SID can be allocated directly from the PCE controlled space .

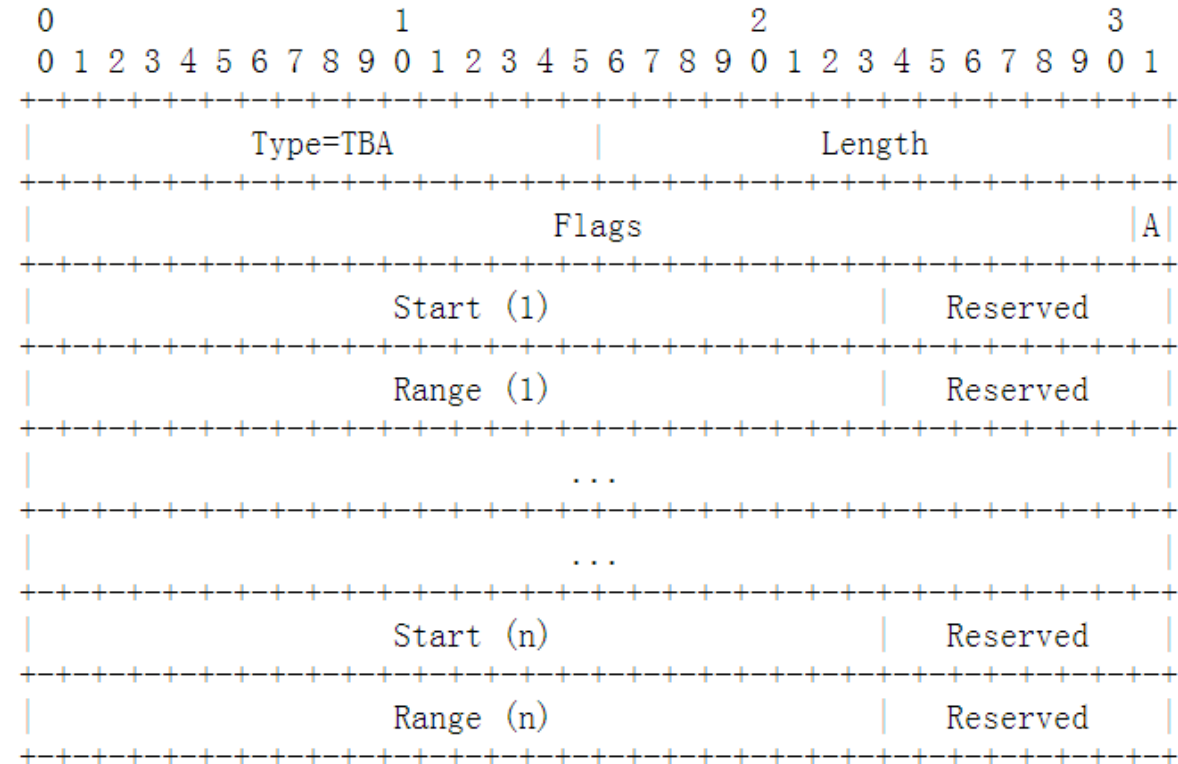

SRv6-PATH-ID-CONTROL-SPACE TLV

- Flags:
 - A: All space flag, set when all the ID space is delegated to a PCE.
- Blocks
 - Start(i) (32 bits): indicates the beginning of the SRv6 Path ID block i.
 - Range(i) (32 bits): indicates the range of the SRv6 Path ID block i.
- Path IDs
 - can be allocated directly from the PCE controlled space .

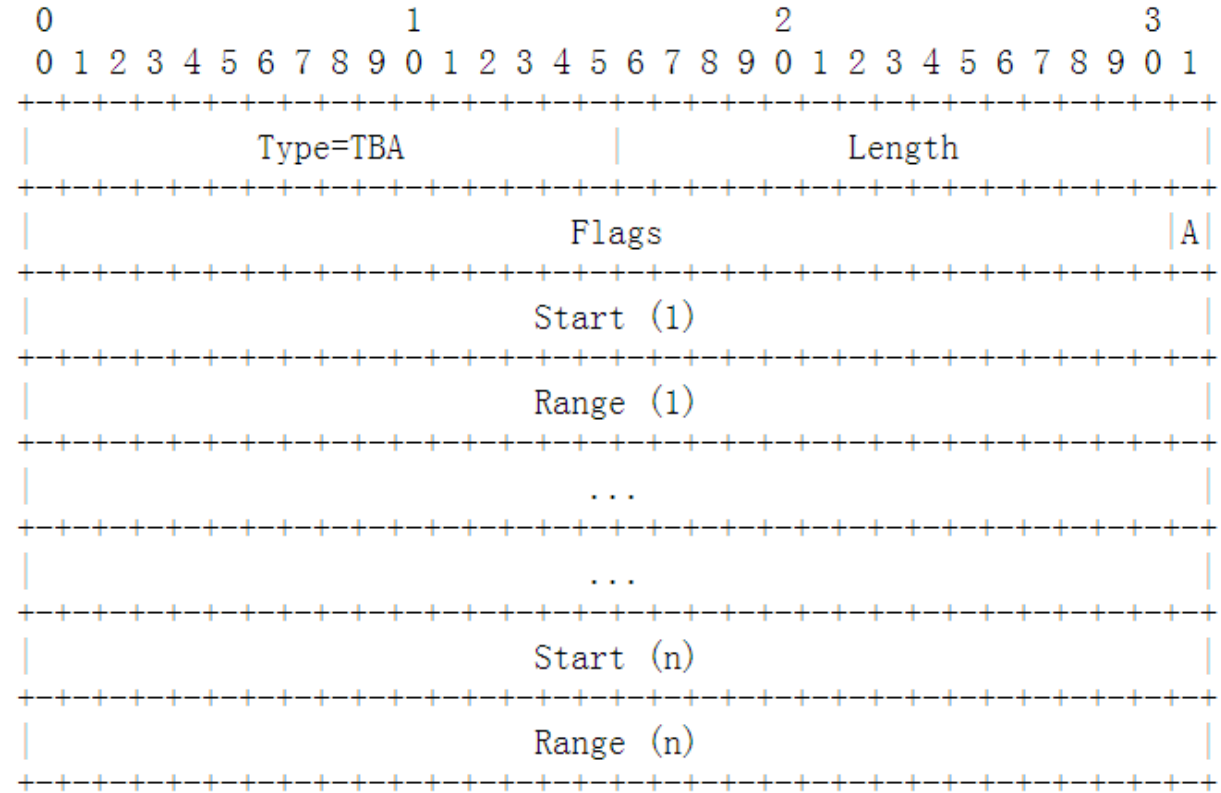

draft-li-pce-sr-path-segment-00

draft-li-pce-sr-path-segment-00

- specifies a mechanism to carry the SR path identification information in PCEP
 - The path ID can be allocated by Ingress PCC itself and informed to the PCE. The PCE can then inform the egress PCC.
 - The PCC can also request PCE to allocate the path ID, in this case, the PCE would allocate and inform the assigned path ID to the ingress/egress PCC using PCEP messages.
 - For PCE can allocate a path ID on its own accord and inform the ingress/egress PCC , useful for PCE-initiated LSPs.
 - (Next Version) The path ID can be allocated by Egress PCC. The PCE should request the Path ID from Egress PCC.

Capabilities Advertisement

- For advertising the capability of Path ID allocation, new flags are required:
 - SR-PCE-CAPABILITY TLV [[I-D.ietf-pce-segment-routing](#)] in OPEN message:
 - P-flag: Path Identification bit, set to indicate that it has the capability to encode SR path identification.
 - SRv6-PCE-CAPABILITY TLV [[I-D.negi-pce-segment-routing-ipv6](#)]
 - P-flag: Path Identification bit, set to indicate that it has the capability to encode SRv6 path identification.

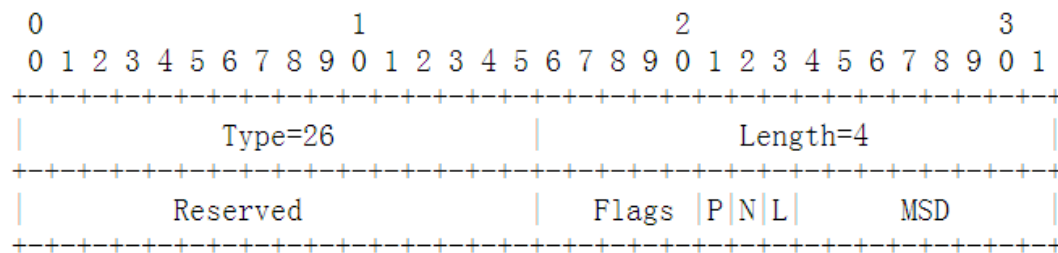

Figure 1: P-flag in SR-PCE-CAPABILITY TLV

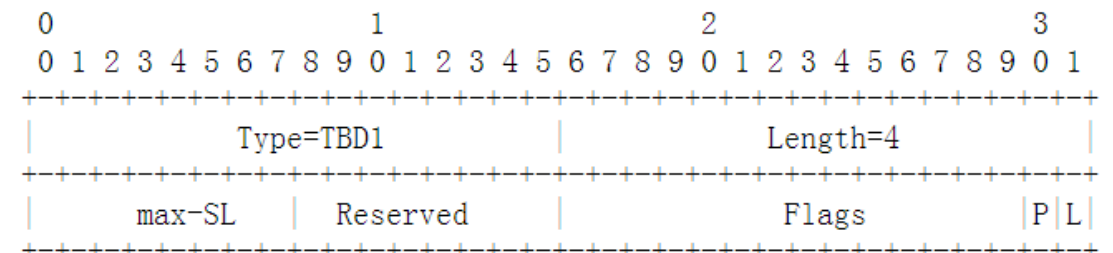

Figure 2: P-flag in SRv6-PCE-CAPABILITY TLV

P-flag in LSP Object

- P-flag: Indicating path ID allocation requirement and path ID allocation reply
 - LSP.P-flag: MUST be set in PCReq/PCRpt msg, when PCC requires the path ID allocation.
 - LSP.P-flag: MUST be set in PCRep/PCUpdate/PCInitiate, when PCE reply the path ID allocation requirement.

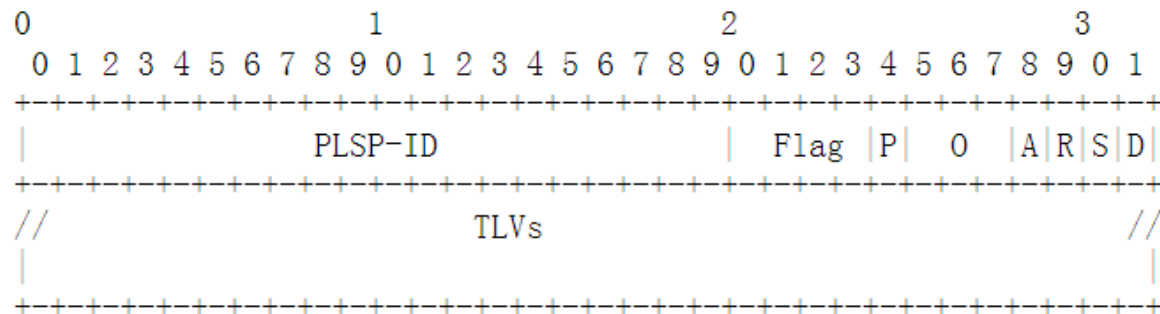
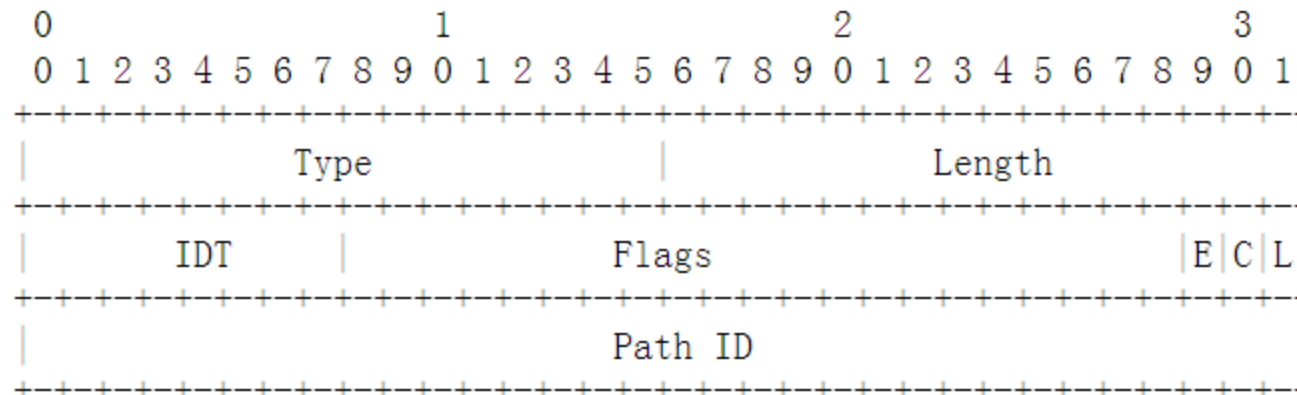

Figure 3: P-flag in LSP Object

Path ID TLV in LSP Object

- IDT (ID type) specifies the type of the Path ID field
 - 0: MPLS Path segment, which is an MPLS label as defined in [[I-D.cheng-spring-mpls-path-segment](#)].
 - 1: SRv6 Path ID, which is a 4-octet integer as defined in [[I-D.li-spring-passive-pm-for-srv6-np](#)].
- Flags
 - L: Local/Global bit: set when the path ID has the local significance.
 - C: PCC/PCE bit: set when the Path ID is allocated by the PCC.
 - E: Egress/Ingress bit: set when the Path ID is allocated from the Egress PCC's ID space.
- Path ID:
 - 32bit value of path ID.
 - The path ID type is indicated by the ID Type field.



Inform the Egress PCC: Path FEC Object & CCI

- This document extends the procedures of [[I-D.zhao-pce-pcep-extension-pce-controller-sr](#)] by defining a new Path FEC object to inform the Path Identification information to the Egress PCC.
- One or more following TLV(s) are allowed in the Path FEC object:
 - SYMBOLIC-PATH-NAME TLV: a human readable string that identifies an LSP in the network [[RFC8231](#)].
 - LSP-IDENTIFIERS TLVs: optional for SR, but could be used to encode the source, destination and other identification information for the path [[RFC8231](#)].
 - SPEAKER-ENTITY-ID TLV: a unique identifier for the PCEP speaker, used to identify the Ingress PCC [[RFC8232](#)]. Can be used for two labels solution defined in [[I-D.cheng-spring-mpls-path-segment](#)].
- The Path ID information is encoded directly in the Central Control Instructions(CCI) SR object. The Path ID TLV MAY

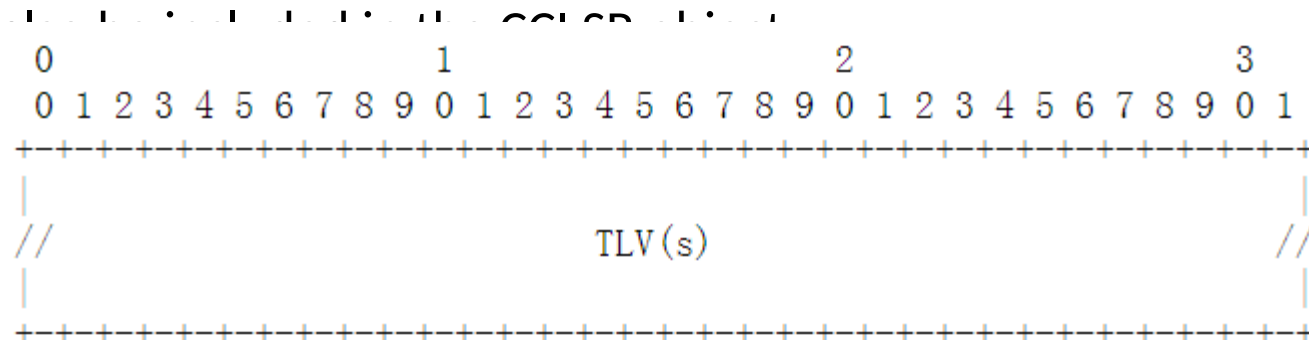

Figure 2: The path FEC object Format

Message Example: PCInitiate

The format of a PCInitiate message is as follows:

```
<PCInitiate Message> ::= <Common Header>
                          <PCE-initiated-lsp-list>
```

Where:

<Common Header> is defined in [RFC 5440](#)

```
<PCE-initiated-lsp-list> ::= <PCE-initiated-lsp-request>
                              [<PCE-initiated-lsp-list>]
```

```
<PCE-initiated-lsp-request> ::= (<PCE-initiated-lsp-instantiation> |
                                  <PCE-initiated-lsp-deletion>)
```

```
<PCE-initiated-lsp-instantiation> ::= <SRP>
                                       <LSP>
                                       [<END-POINTS>]
                                       <ERO>
                                       [<attribute-list>]
```

```
<PCE-initiated-lsp-deletion> ::= <SRP>
                                  <LSP>
```

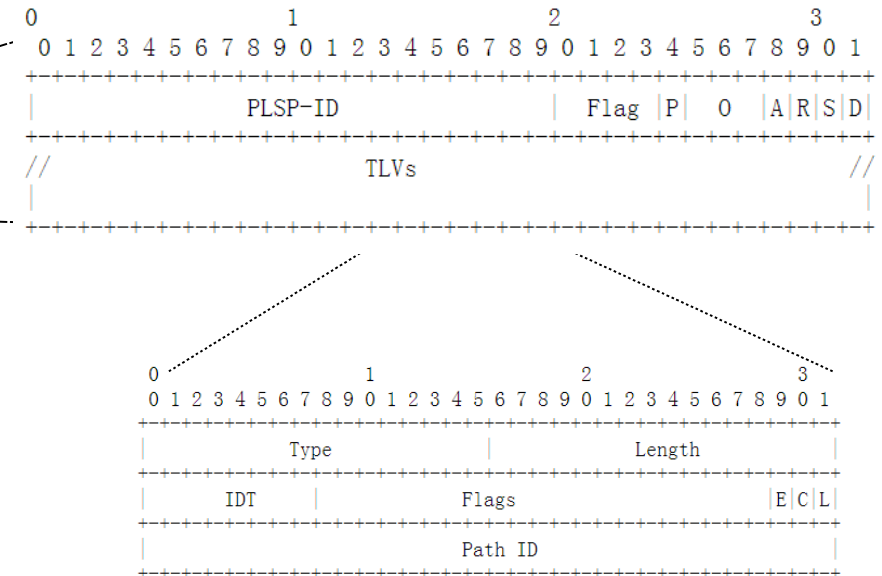

Example: PCE allocated Path ID on its own

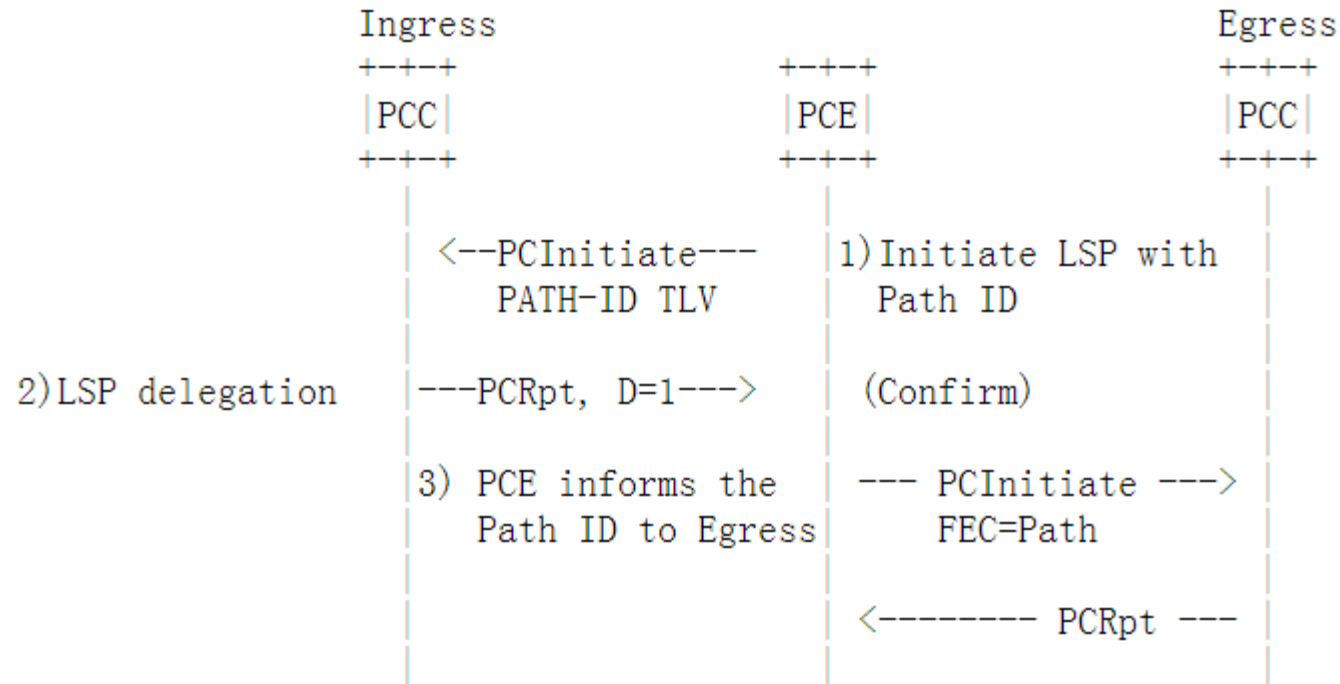

Figure 5: PCE allocated Path ID on its own

draft-li-pce-sr-bidir-path-00

draft-li-pce-sr-bidir-path-00

- For associating two SR paths, this document defines a new association group called 'Double-sided Bidirectional SR Path Association Group'
 - The paths belonging to this association is conveyed via PCEP messages to the PCEP peer.
 - A member of the Double-sided Bi-directional SR Path Association Group can take the role of a forward or reverse SR path.
 - The handling rules are set in the same way as [[I-D.ietf-pce-association-bidir](#)].
- B-flag in RP and SRP object MUST be set.
- The PATH-ID TLV [[I-D.li-pce-sr-path-segment](#)] MUST also be included in the LSP object for these SR paths.

Example: PCE-Initiated Bidir Path

- A stateful PCE:
 - Create/update the forward/reverse SR path independently
 - Establish/remove the association relationship on a per SR path basis.
 - Create/update the SR path and the association on a PCC via PCInitiate/PCUpd messages, respectively.
- The Path-ID TLV MUST be included for each SR path in the LSP object.
- The opposite direction SR SHOULD be informed via PCInitiate message with the matching association group.

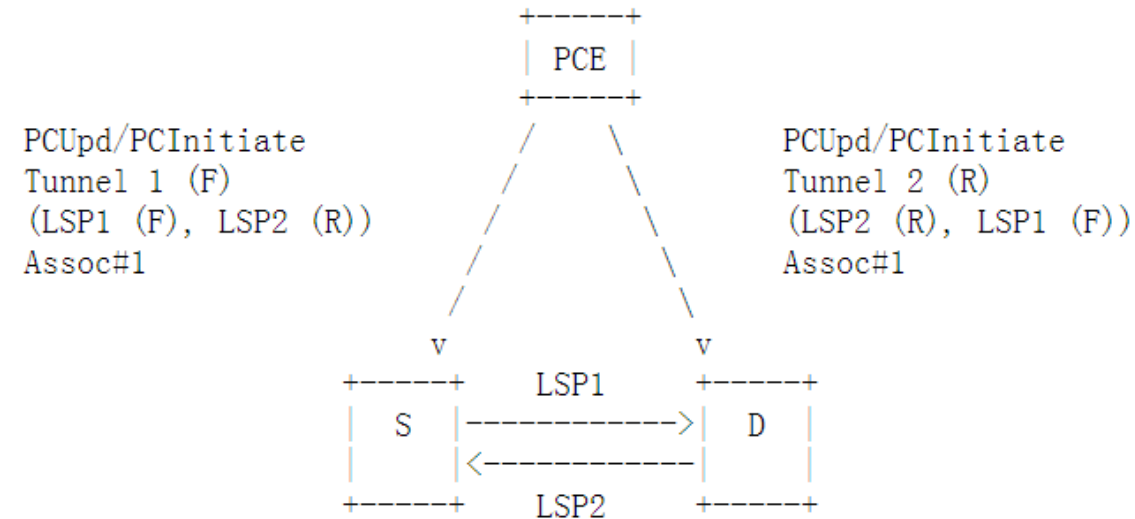

Figure 1: PCE-Initiated Double-sided Bidirectional SR Path

Thank you