

draft-guichard-spring-nsh-sr-00

J. Guichard, Huawei

H. Song, Huawei

J. Tantsura, Nuage Networks

J. Halpern, Ericsson

W. Henderickx, Nokia

M. Boucadair, Orange

IETF 103, Bangkok

Basic Intention of the Draft

- Describes two application scenarios where Network Service Header (NSH) and Segment Routing (SR) can be deployed together to support Service Function Chaining (SFC) in an efficient manner while maintaining separation of the service and transport planes as originally intended by the SFC architecture
- Scenario #1: NSH-based SFC with SR-based transport:
 - in this scenario segment routing provides the transport encapsulation between SFFs while NSH is used to convey and trigger SFC polices
- Scenario #2: SR-based SFC with integrated NSH service plane:
 - in this scenario each service hop of the SFC is represented as a segment of the SR segment-list. SR is responsible for steering traffic through the necessary SFFs as part of the segment routing path and NSH is responsible for maintaining the service plane, and holding the SFC instance context and associated metadata

NSH-based SFC with SR as the Transport Tunnel

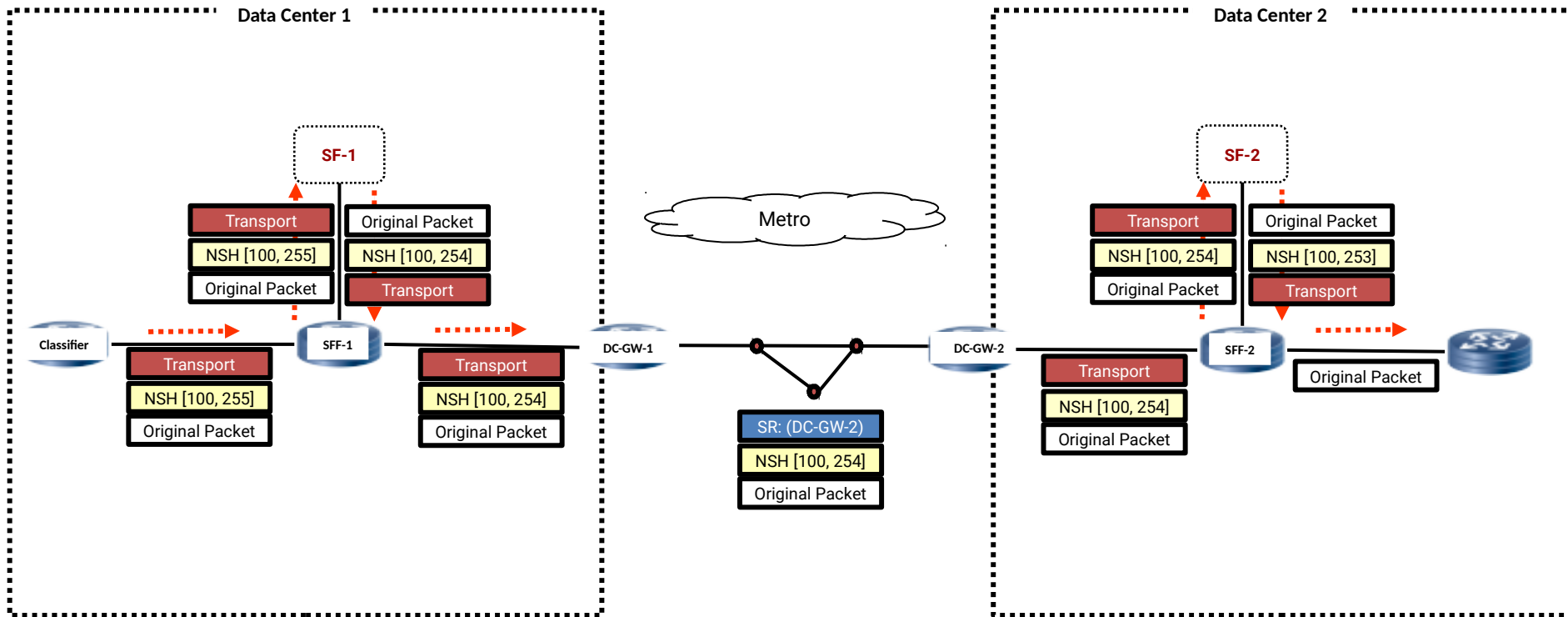

SR-based SFC with Integrated NSH Service Plane

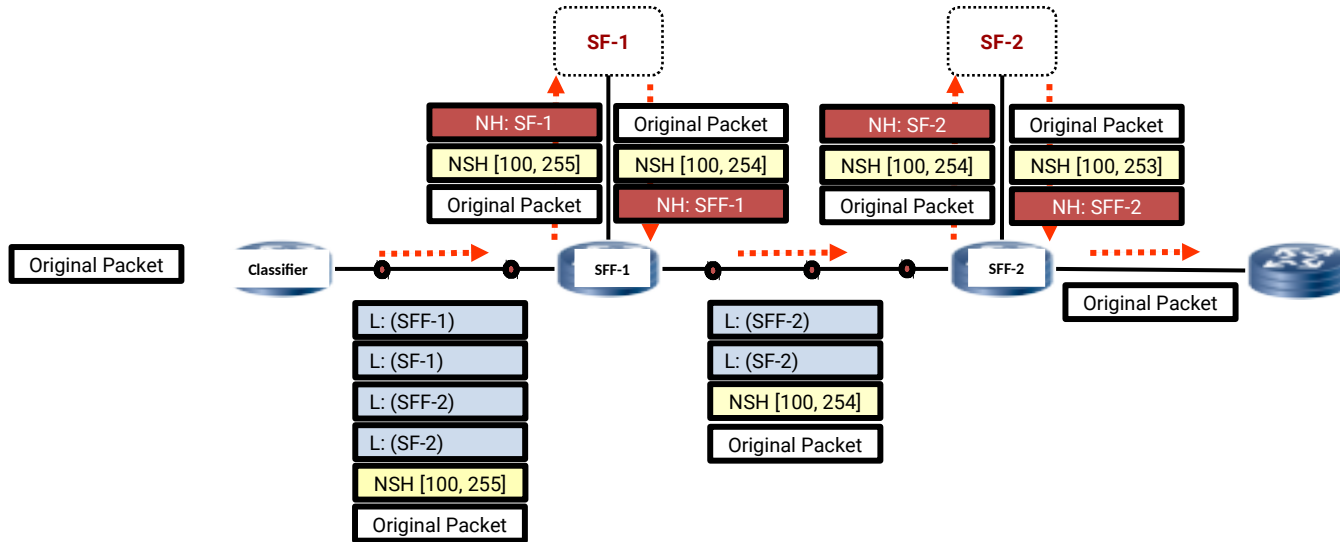

Encapsulation Details

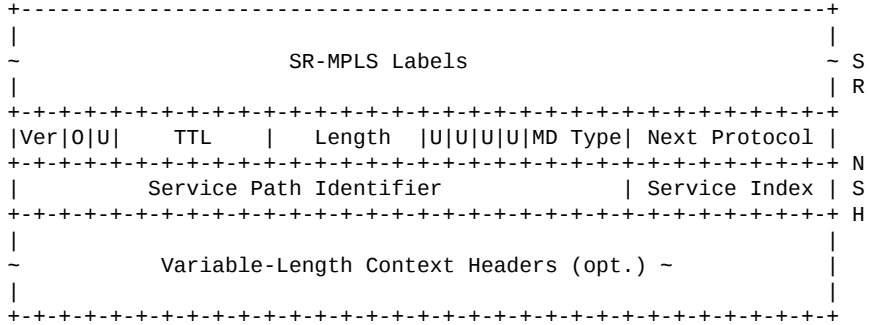

SR-MPLS

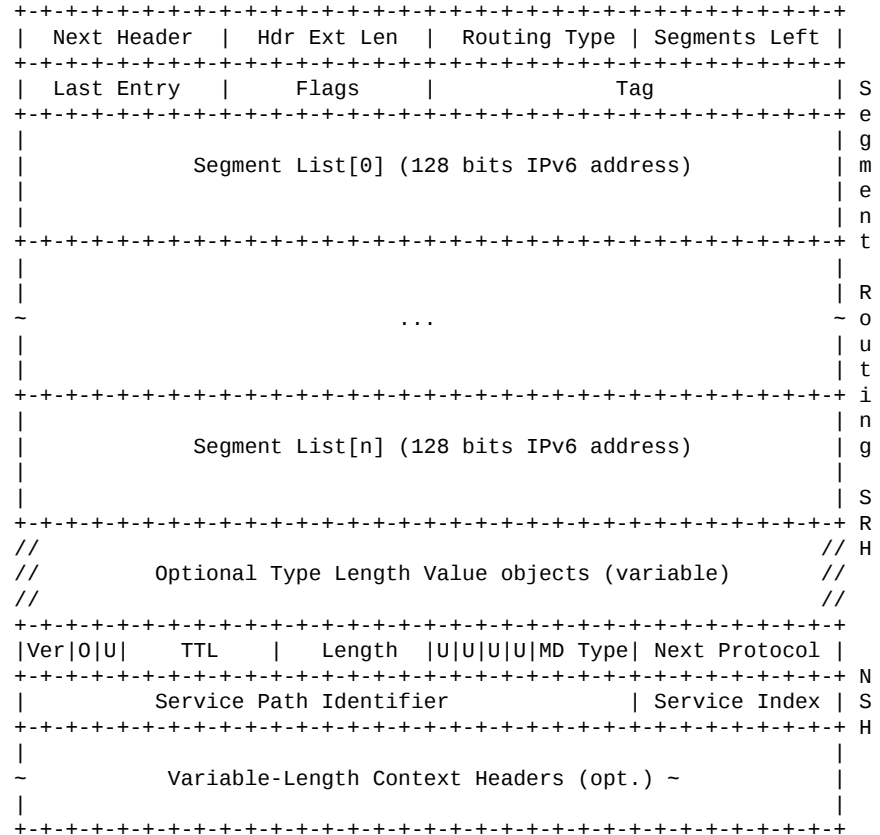

SRv6

Changes since IETF 102

- Draft name change to draft-guichard-spring-nsh-sr-00 to reflect desired WG progression
- Added more details on SFF-SF interaction and layering between SR and NSH
- Added more detail for SRv6 encapsulation
 - indicating UDP in the Next Header field of the SRH, or
 - by indicating an IP protocol number for NSH in the Next Header of the SRH
- IANA considerations updated
 - Requires UDP port numbers for NSH and IP protocol number

Conclusions

- NSH-based service chaining and segment routing are complimentary technologies
- SR based SFC has several options, each has its own pros and cons
- NSH is designed to be transport agnostic, NSH based SFC is more and more accepted by the industry
- Segment Routing(SR) provides an efficient way for steering traffic without requiring intermediate nodes to maintain per-flow state
- By combining SR and NSH, a transport-independent SFC can be realized
- A solution that keeps merits of both NSH and SR is attractive

Next Steps

- Request WG adoption in SPRING WG
- Continue to refine technical details