

# HotRFC

## Open Congestion Control Architecture with network cooperation for RDMA Fabric

**draft-yueven-tsvwg-dccm-requirements-01**  
**draft-zhh-tsvwg-open-architecture-00**

Roni Even (presenter), Yolanda Yu  
Yan Zhuang, Rachel Huang



# Motivation

- The high link speed (100Gb/s) in Data Centers (DC) are making network transfers complete faster and in fewer RTTs. Short data bursts requires low latency while longer data transfer require high throughput.
- RDMA is the common protocol in DC network. However, the congestion control is not optimized for different usages and lacks interoperability. Allowing for flexibility in running an optimized congestion method in the NIC and having fast congestion notification to the sender can improve the RDMA data transfer.
- It's common in DC network that TCP traffic is mixed with RDMA traffic.
- Is there a better method that could solve the problems mentioned above while addressing interoperability so that RDMA traffic can be treated more efficiently?

# Open Control Architecture

- The requirement document [draft-yueven-tsvwg-dccm-requirements-01](#) discusses major problems of current Remote Direct Memory Access (RDMA) fabric congestion handling technologies and the requirements for better performance.
- The architecture document [draft-zhh-tsvwg-open-architecture-00](#) proposes an open control architecture of hosts and networks for the high performance RDMA fabric to provide better congestion handling for High Performance Computing (HPC) and distributed storage accessing applications which requires low latency and high throughput.

# Open Control Architecture

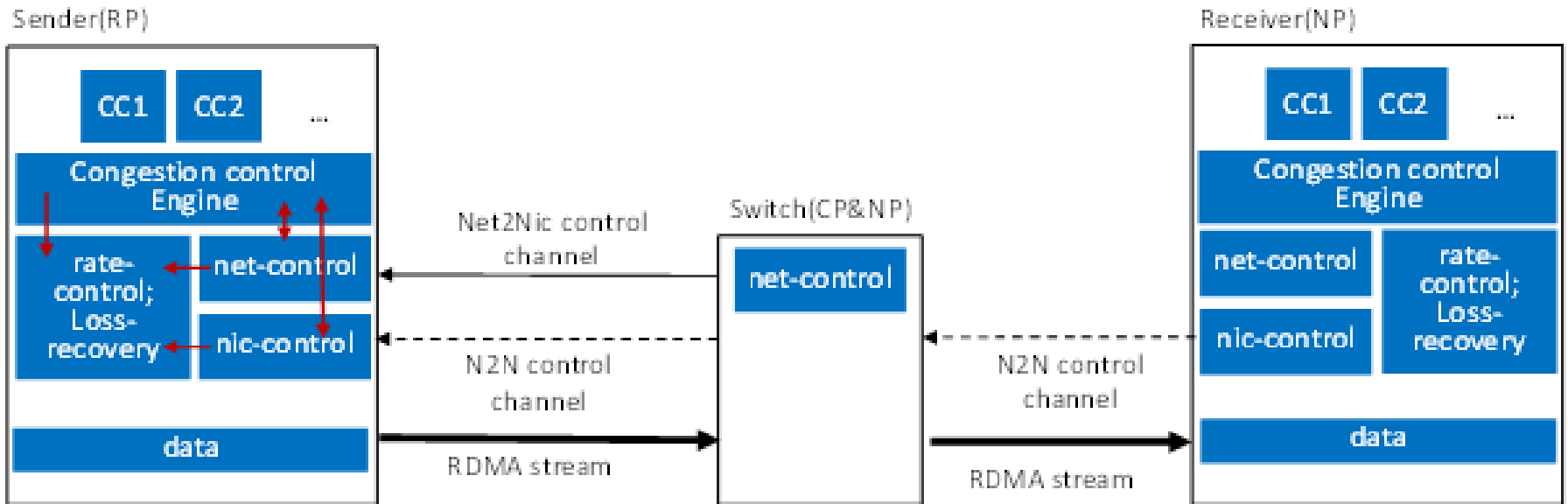

# Design Considerations

- Provide better information about congestion state to the sender (faster and more accurate). Notify the sender (re-action point) from the network.
- Support proactive response from the notification point.
- Support RDMA transports (iWARP and ROCE).
- Support multiplexed traffic of RDMA and TCP.

# Thank you!

- **If you are interested please attend the side meeting on Monday 8:30AM - 9:45AM in the Notre Dame room.**
- You can catch me during the week or email me at [roni.even@huawei.com](mailto:roni.even@huawei.com) .