

# Carrying VTN-ID in MPLS Packet

*draft-li-mpls-enhanced-vpn-vtn-id-00*

Zhenbin Li, Jie Dong @Huawei

# Background

- A VTN is a virtual underlay network with the customized topology and a set of dedicated or shared network resources
  - Introduced in *draft-ietf-teas-enhanced-vpn* as the underlay of VPN+ services
- The information of the associated VTN needs to be carried in data packet
  - To steer packets to the set of network resources allocated to the VTN
  - The VTN information needs to be processed on each hop along the path in packet forwarding
- This document proposes a mechanism to carry the VTN ID and related information in MPLS packet
  - Applicable to both SR-MPLS and traditional MPLS networks

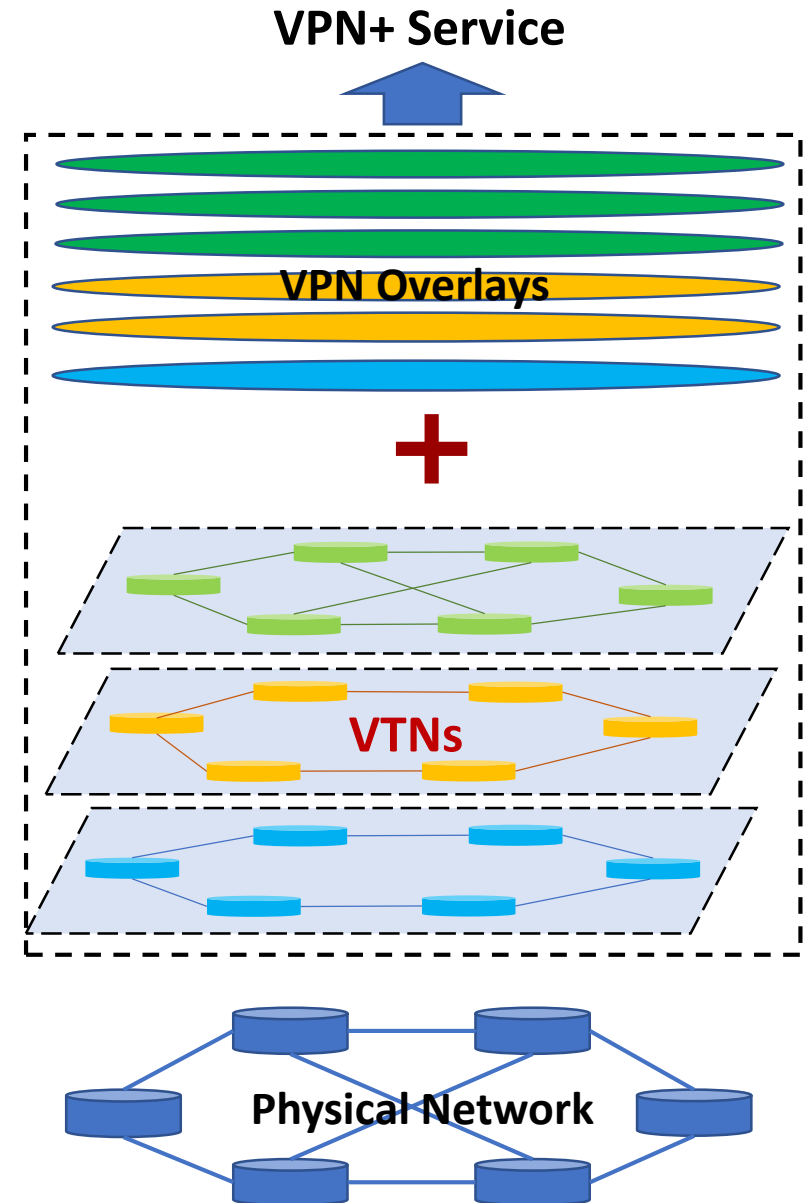

# Mechanisms in this draft

- A new VTN header is defined to carry the VTN ID and the related information
  - Follows the MPLS label stack, precedes the header and payloads of the upper layer
  - The Existence is identified by a special purpose label called “VHI”

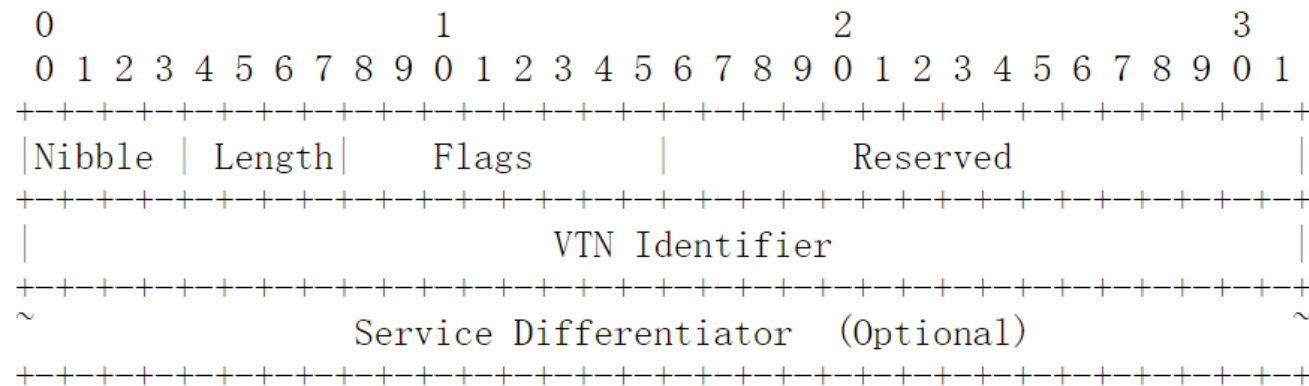

- **Nibble:** set to 0010, ensures that it is not interpreted as an IP header, ACH or CW.
- **Length:** length of the header in 32-bit words
- **VTN ID:** 4-octet identifier of a VTN
- **Service Differentiator:** variable length optional information about the service carried by this VTN. E.g. could be the S-NSSAI for 5G network slicing

# Procedures

- VTN header insertion
  - Ingress node of an LSP encapsulates VTN header together with the MPLS label stack, according to traffic classification or mapping policy
- VTN based packet forwarding
  - Nodes which support VTN look for the VHL in the label stack
  - If there is a VHL, the forwarding behavior is based on both the top label and the VTN header
    - The top MPLS label is used to determine the next-hop
    - The VTN-ID identifies the local resources allocated to the VTN for packet processing
    - The Service Differentiator may be used to provide finer-grained differentiation and processing
- VTN header decapsulation
  - Egress node of an LSP pops the VHL and decapsulate the VTN header

# Capability Advertisement and Negotiation

- Before inserting the VTN header into an MPLS packet, the ingress node needs to know whether the nodes along the LSP can process the VTN header properly according to the mechanisms defined in this document
- The capability advertisement and negotiation mechanism for the VTN header will be provided in a future version

# Next Steps

- Comments and feedbacks are welcome

Thank You