

DetNet

MPLS Data Plane

(RFC 8964)

Balázs Varga

PALS – MPLS – DetNet - SPRING WGs joint

IETF-110, Virtual, 12th March, 2021

DetNet Data Plane: MPLS

- RFC 8964
 - specifies the Deterministic Networking data plane when operating over an MPLS Packet Switched Networks.

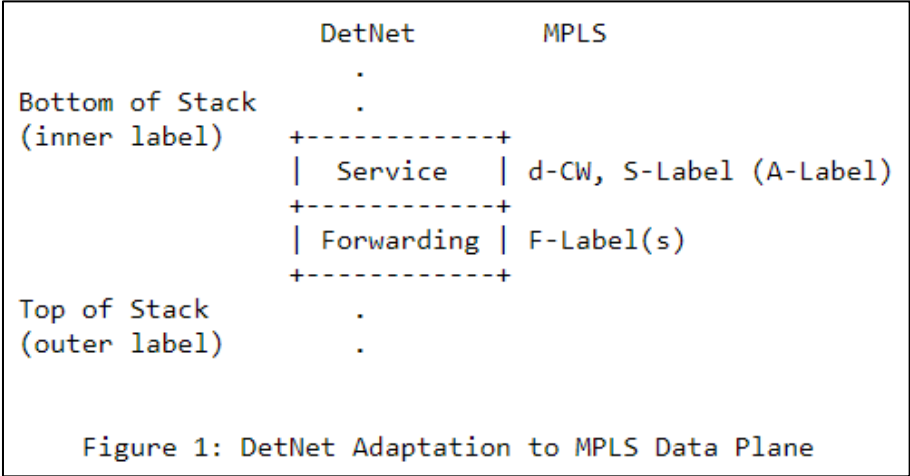

- DetNet MPLS Data Plane
 - DetNet service sub-layer
 - DetNet forwarding sub-layer
- DetNet MPLS Data Plane Procedures
 - Flow identification: Labels
 - Sequence number: d-CW

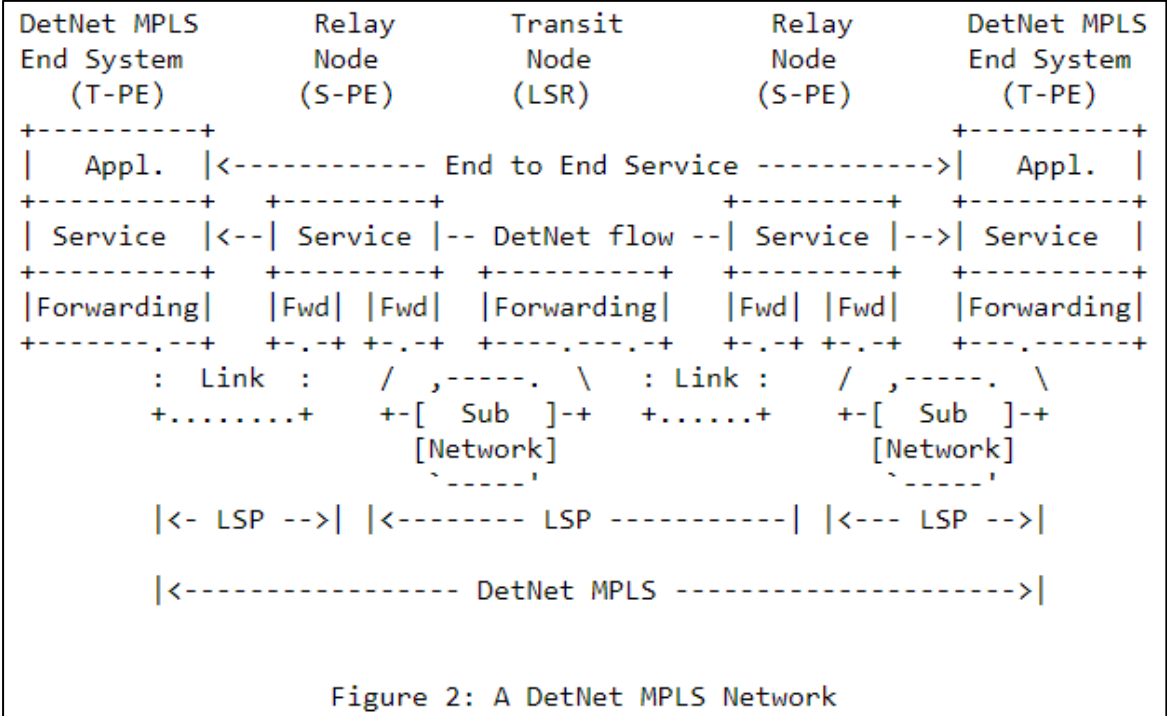

DetNet: PREOF function

How it works ... (RFC8655)

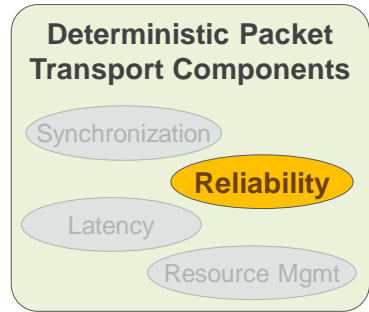

- PREOF: Packet Replication, Elimination and Ordering Function

- Basics:

- Per packet 1+1 (1+N) redundancy
- Send packets on two (or more) disjoint paths, then combine and delete extras
- No primary/backup paths differentiated, all paths are active (“zero switchover time”)

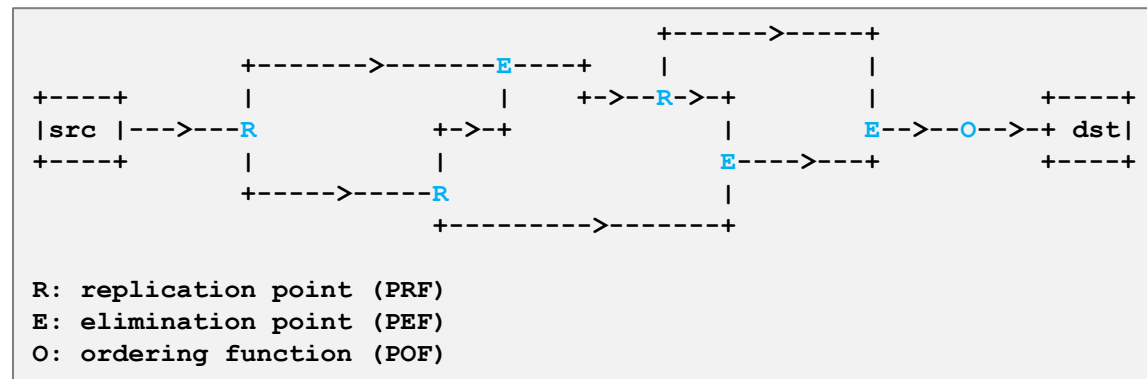
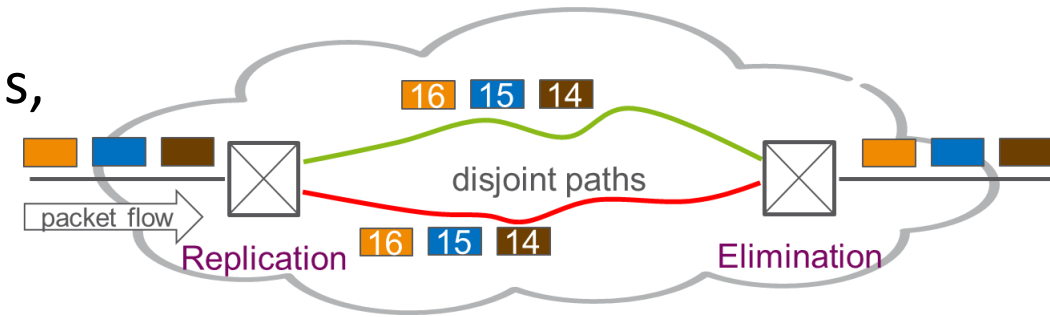

MPLS data plane – Encapsulation

DetNet PW

- MPLS-based DetNet data plane encapsulation:
 - **DetNet control word (d-CW)** containing sequencing information for packet replication and duplicate elimination purposes, and the OAM indicator.
 - **DetNet service Label (S-label)** that identifies a DetNet flow to the peer node that is to process it.
 - Zero or more MPLS forwarding LSP label(s) (F-label) used to direct the packet along the label switched path (LSP) to the next peer node.
 - The necessary data-link encapsulation is then applied prior to transmission over the physical media.

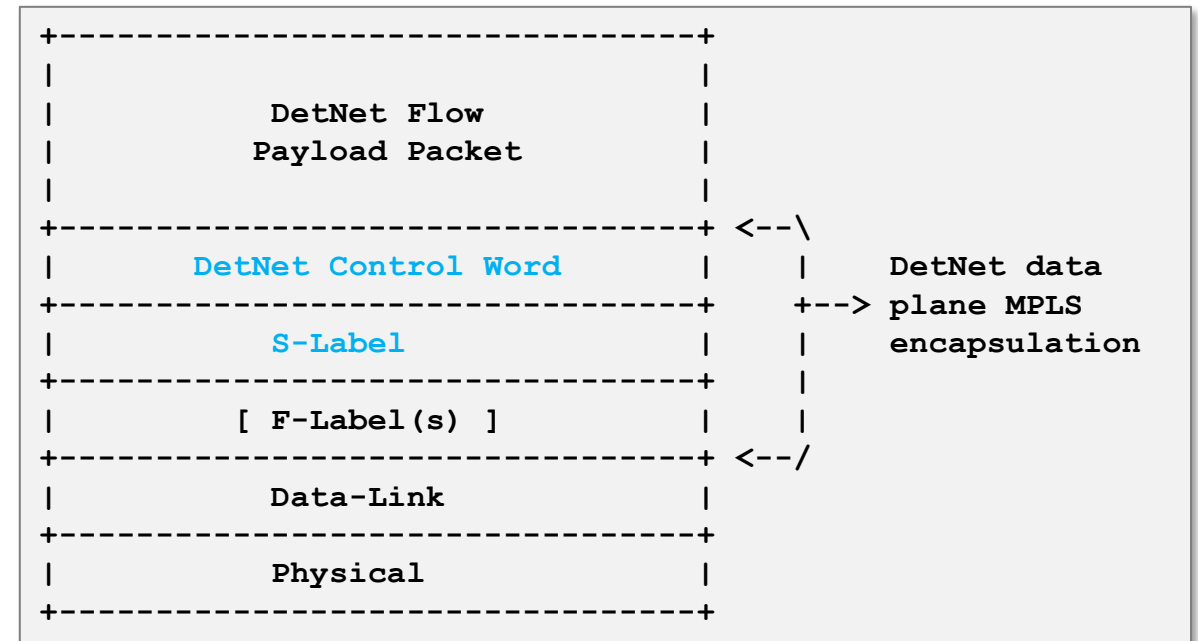

MPLS data plane – Encapsulation

DetNet control word

- d-CW:

- d-CW **MUST always be present** in a packet (even if it is not used)
- A DetNet control word (d-CW) conforms
 - to the Generic PW MPLS Control Word (PWMCW) defined in [RFC4385]
- Two sequence number sizes are supported:
 - **16** bits and **28** bits.
- The sequence number size
 - in use for the d-CW associated with a DetNet flow (S-Label) is configured either by a controller plane or manually for each DetNet flow.
- **Zero is an ordinary sequence number** with no special meaning

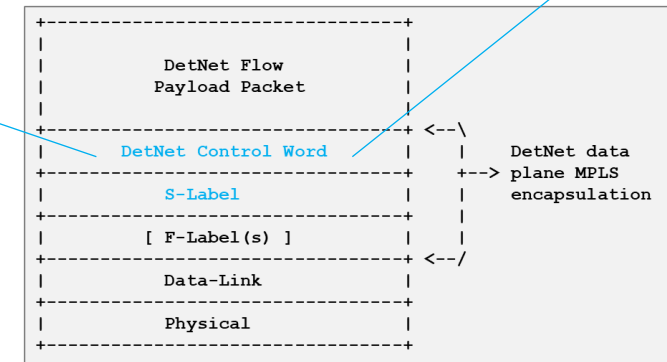
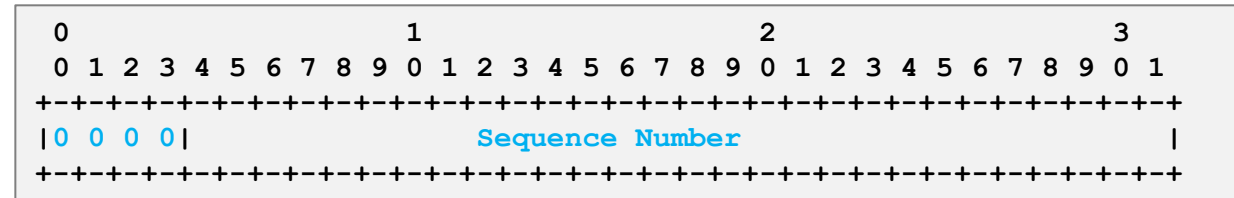

Thanks ...