



Thursday 2021/03/11

IETF 110 ROLL - online

Routing over Low-Power And Lossy Networks

Chairs:

Dominique Barthel

Ines Robles

Secretary:

Michael Richardson



Note Well

This is a reminder of IETF policies in effect on various topics such as patents or code of conduct. It is only meant to point you in the right direction. Exceptions may apply. The IETF's patent policy and the definition of an IETF "contribution" and "participation" are set forth in BCP 79; please read it carefully.

As a reminder:

- By participating in the IETF, you agree to follow IETF processes and policies.
- If you are aware that any IETF contribution is covered by patents or patent applications that are owned or controlled by you or your sponsor, you must disclose that fact, or not participate in the discussion.
- As a participant in or attendee to any IETF activity you acknowledge that written, audio, video, and photographic records of meetings may be made public.
- Personal information that you provide to IETF will be handled in accordance with the IETF Privacy Statement.
- As a participant or attendee, you agree to work respectfully with other participants; please contact the ombudsteam (<https://www.ietf.org/contact/ombudsteam/>) if you have questions or concerns about this.

Definitive information is in the documents listed below and other IETF BCPs. For advice, please talk to WG chairs or ADs:

BCP 9 (Internet Standards Process)

BCP 25 (Working Group processes)

BCP 25 (Anti-Harassment Procedures)

BCP 54 (Code of Conduct)

BCP 78 (Copyright)

BCP 79 (Patents, Participation)

<https://www.ietf.org/privacy-policy/> (Privacy Policy)

Source: <https://www.ietf.org/about/note-well/>

Meeting Materials

- Session: Thursday, 11th March 2021 - 14:30-15:30 UTC
- Remote Participation
 - Meetecho: <https://meetings.conf.meetecho.com/ietf110/?group=roll&short=&item=1>
 - CodiMD: <https://codimd.ietf.org/notes-ietf-110-roll>
 - Material: <https://datatracker.ietf.org/meeting/110/session/roll>
 - Jabber: xmpp:[roll@jabber.ietf.org](xmpp:roll@jabber.ietf.org)?join
 - Minute takers: **Please volunteer, thank you :)**

Agenda

Time	Duration	Draft/Topic	Presenter
14:30 - 14:38	8 min	WG Status	Ines/Dominique
14:38 - 14:53	15 min	draft-ietf-roll-dao-projection	Pascal
14:53 - 15:13	20 min	RFC6550bis status	Michael
15:13 - 15:21	8 min	draft-ietf-roll-enrollment-priority	Michael
15:21 - 15:29	8 min	draft-ietf-roll-mopex draft-ietf-roll-capabilities	Rahul
15:29 - 15:30	As time permits	Open Floor	Everyone

State of Active Internet-Drafts

	Draft	Status
2 IPRs	draft-ietf-roll-efficient-npdao-18	RFC Ed Queue
	draft-ietf-roll-turnon-rfc8138-18	RFC Ed Queue
	draft-ietf-roll-unaware-leaves-30	RFC Ed Queue
	draft-ietf-roll-useofrplinfo-44	RFC Ed Queue
1 IPR	draft-ietf-roll-capabilities-07	Discussion Today
	draft-ietf-roll-dao-projection-16	Discussion Today
	draft-ietf-roll-enrollment-priority-04	Discussion Today
	draft-ietf-roll-mopex-02	Discussion Today
2 IPRs	draft-ietf-roll-nsa-extension-10	Submitted to the IESG for publication
	draft-ietf-roll-aodv-rpl-09	AD Evaluation::Revised I-D Needed
	draft-ietf-roll-dis-modifications-01	Stand By
	draft-ietf-roll-rpl-observations-05	Work in progress

Related Internet-Drafts

Draft	Status
draft-jadhav-roll-storing-rootack-02	Call for adoption issued Jan 26th
draft-thubert-roll-eliding-dio-information	Expired - To be Continued later -

State of inactive Internet-Drafts

Draft	Status
Draft-ietf-roll-mpl-yang-02 (Expired)	To be continued
Draft-ietf-roll-bier-ccast-01 (Expired)	To be continued

Done Milestones

Date ↕ Milestone

- | | |
|------|---|
| Done | Initial submission to the IESG of mechanism to turn on RFC8138 compression feature within a RPL network
draft-ietf-roll-turnon-rfc8138 |
| Done | Initial submission of routing for RPL Leaves draft to the IESG
draft-ietf-roll-unaware-leaves |
| Done | Initial submission of a reactive P2P route discovery mechanism based on AODV-RPL protocol to the IESG
draft-ietf-roll-aodv-rpl |
| Done | Initial Submission of a proposal with uses cases for RPI, RH3 and IPv6-in-IPv6 encapsulation to the IESG
draft-ietf-roll-useofrplinfo |
| Done | Initial submission of a solution to the problems due to the use of No-Path DAO Messages to the IESG |

Milestones

Date ↕	Milestone
Jun 2020	Initial submission of a proposal for Source-Route Multicast for RPL to the IESG draft-ietf-roll-ccast
Jun 2020	Initial submission of a proposal to augment DIS flags and options to the IESG draft-ietf-roll-dis-modifications
Jul 2020	Initial submission of a root initiated routing state in RPL to the IESG draft-ietf-roll-dao-projection
Jul 2020	Initial submission of a YANG model for MPL to the IESG draft-ietf-roll-mpl-yang
Mar 2020	Initial submission of Common Ancestor Objective Functions and Parent Set DAG Metric Container Extension to the IESG draft-ietf-roll-nsa-extension
Jun 2020	Initial submission of Enabling secure network enrollment in RPL networks draft to the IESG draft-ietf-roll-enrollment-priority
Dec 2020	Initial submission of Mode of Operation extension and Capabilities for RPL to the IESG draft-ietf-roll-mopex-cap
Oct 2021	Recharter WG or close

Tickets

- <https://trac.ietf.org/trac/roll/report/2>
 - aadv-rpl (#199, #200), dao-projection (#179, #180), RPLv2 (#187, #188)
- <https://github.com/roll-wg/xxx/issues>
 - rpl-observations (4)
 - dao-projections (5)
 - efficient-route-invalidation (1)
 - Capabilities (6)

Root initiated routing state in RPL

draft-ietf-roll-dao-projection

P. Thubert, Ed.; R.A. Jadhav, M. Gillmore

Pascal Thubert

IETF 110

ROLL Virtual Meeting

Status to the draft

- Published -15 and -16 since last IETF
- Non-Storing Mode SRH may be loose
- Main DODAG MUST be Non-Storing Mode
- Track \Leftrightarrow Non-Storing Mode main DODAG:
 - Root is Track Ingress,
 - Signaled by one or more Non-Storing-Mode P-DAO messages
 - Track Ingress encapsulates external packets (as in useofrplinfo)
 - Track Ingress places the SRH in the packet in source routed tracks
 - There cannot be non-storing segments (only Tracks withing Tracks)
- Storing Mode P-DAO signals Segment of a Track or of main DODAG
 - Does not need re-encapsulation
 - Unless implicit Track \Rightarrow Do we support that ?



*See the VLA
Info Option as a
multihop Transit
Info Option*

Status to the draft (cont)

- RPI modified to indicate P-Route
- Extending RFC 6553 and RFC 8138

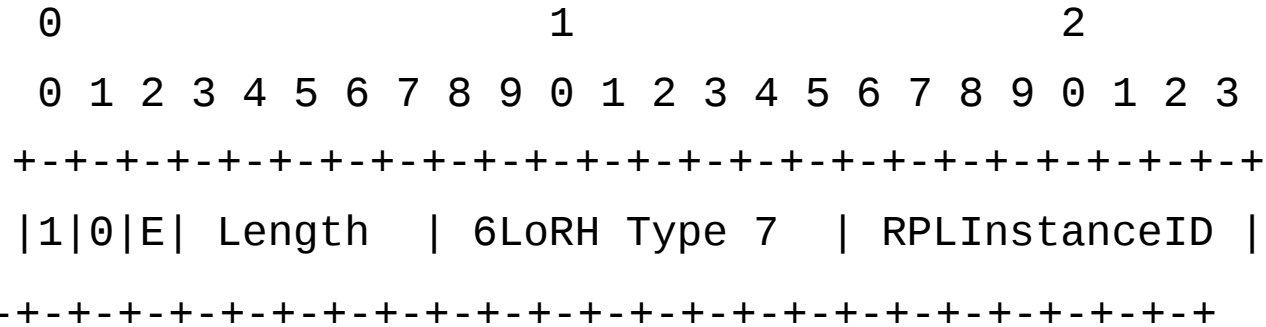

- New P-RPI-6LoRH, both elective and non-elective forms

P-DAO construction

- RPL Target Options can be factorized
- But there is one and only one VIO (SF-VIO or SR-VIO)
- So the Ack management is easier
- VIO sent to egress; SR-VIO sent to ingress
- Track ID is a RPL local instance ID
- Taken from the Track Egress Name Space

Encapsulation and signaling

- Several Profiles to simplify implementations
- All with the same model based on
 - non-storing mode for the loose tracks : segment routing
 - Storing mode to signal the segments that fill the loose hops
- Tracks are local instances
- useofrplinfo applies for encapsulation of external targets

Encapsulation Details

- Source of outer header MUST be Track Ingress- think DODAG Root
- RPL Instance ID in RPI MUST indicate TrackID (if not main DODAG)
- SR-VIO: Loose from Track Ingress, excluded, to Egress, included
 - Copied Verbatim in inserted SRH-6LoRH,
 - Requires encapsulation (can be recursive)
- SF-VIO: Strict from Segment Ingress to Egress, both included
 - No Encapsulation if Source and RPI both match Segment definition
 - A Segment is an Implicit Track if P-DAO Ingress == 1st SF-VIO entry
- TBD: matching rules, Flow Info option, when to tunnel?

Profile 1:

Compress SRH in main DODAG with strict SM Segments

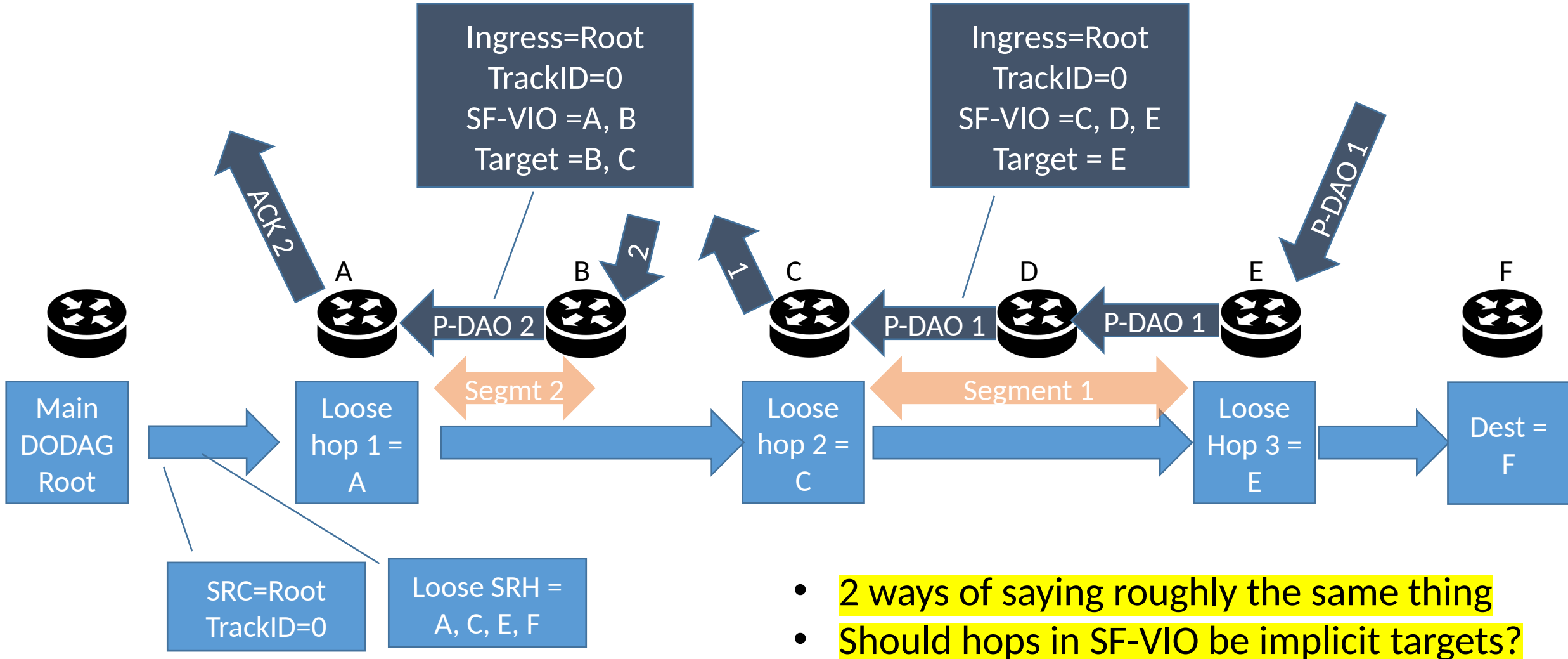

Profile 2: Compress SRH in main DODAG with Strict NSM Tracks

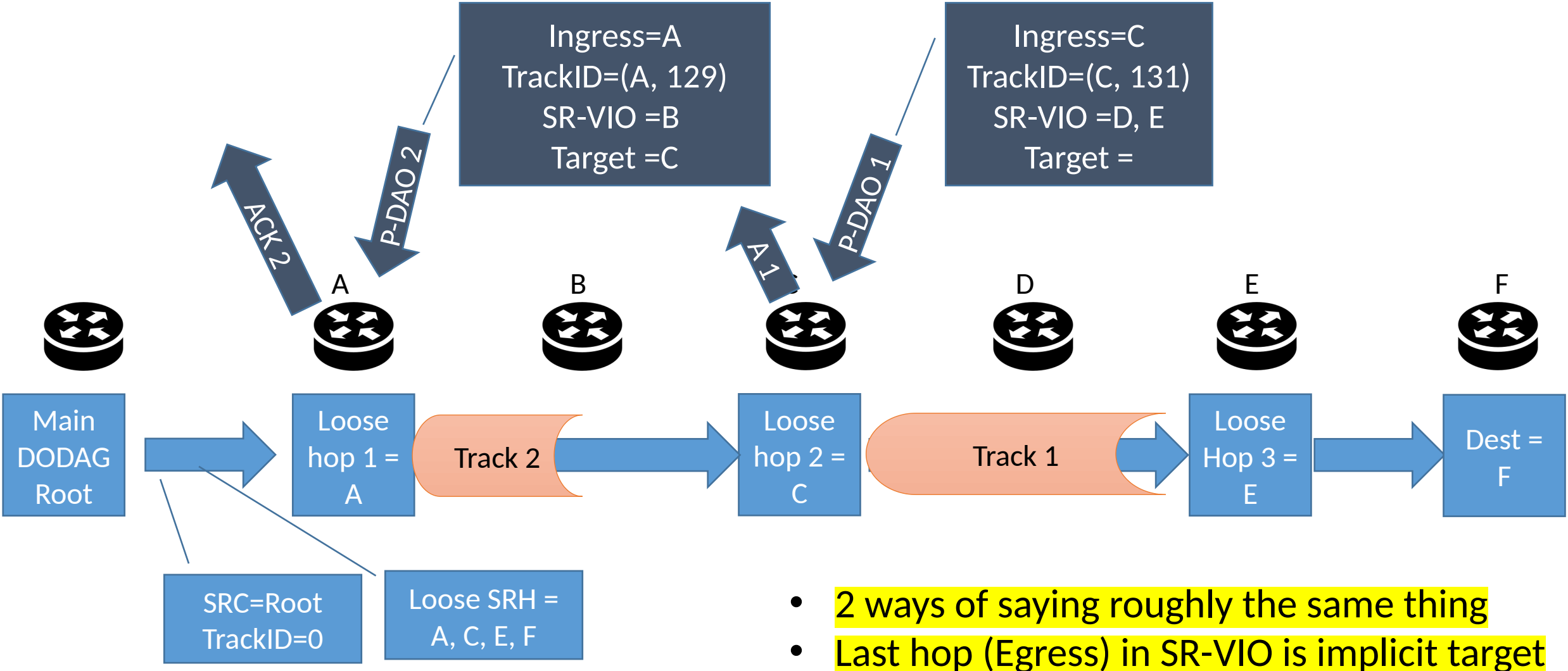

Profile 3: Implicit Track with Strict SM Segments,

Need Sibling Information

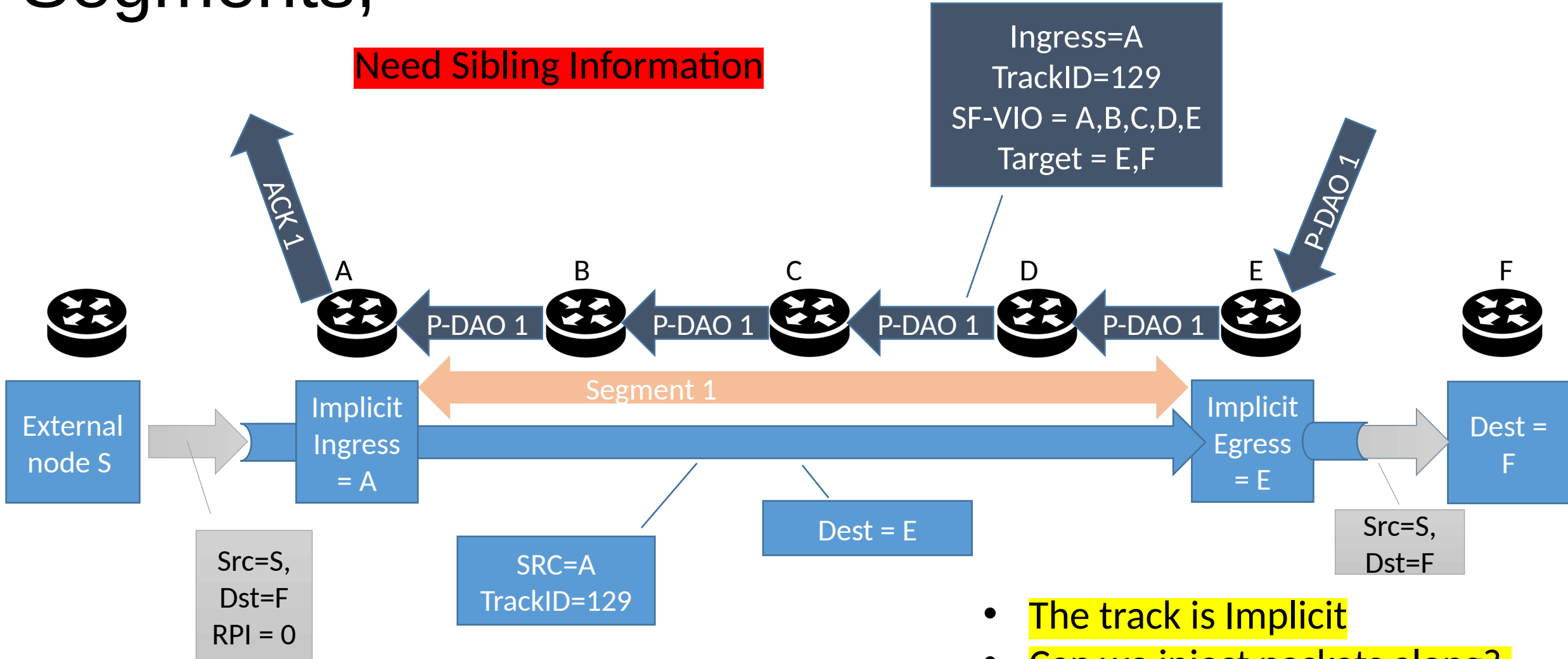

- The track is Implicit
- Can we inject packets along?

Profile 4: Strict NSM Explicit Track

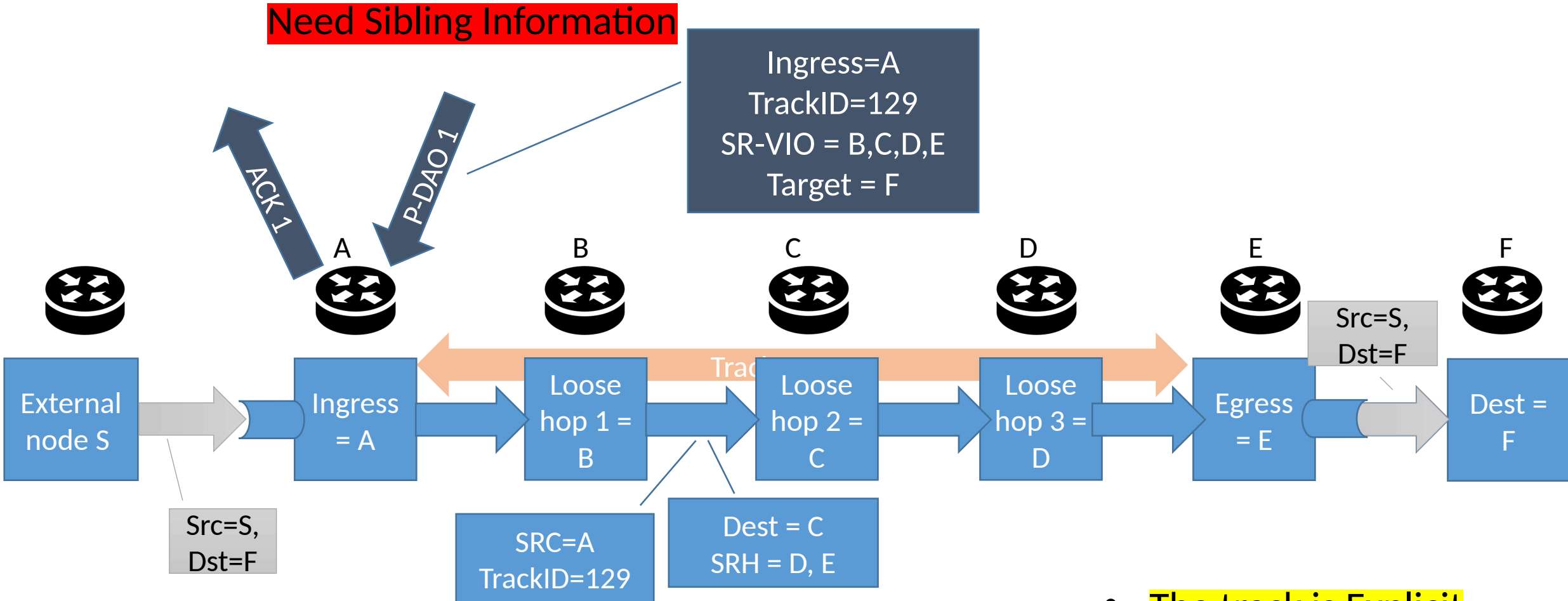

- The track is Explicit
- Same encap as profile 2

Profile 5:

Need Sibling Information

Compress SRH in Track with Strict SM Segments

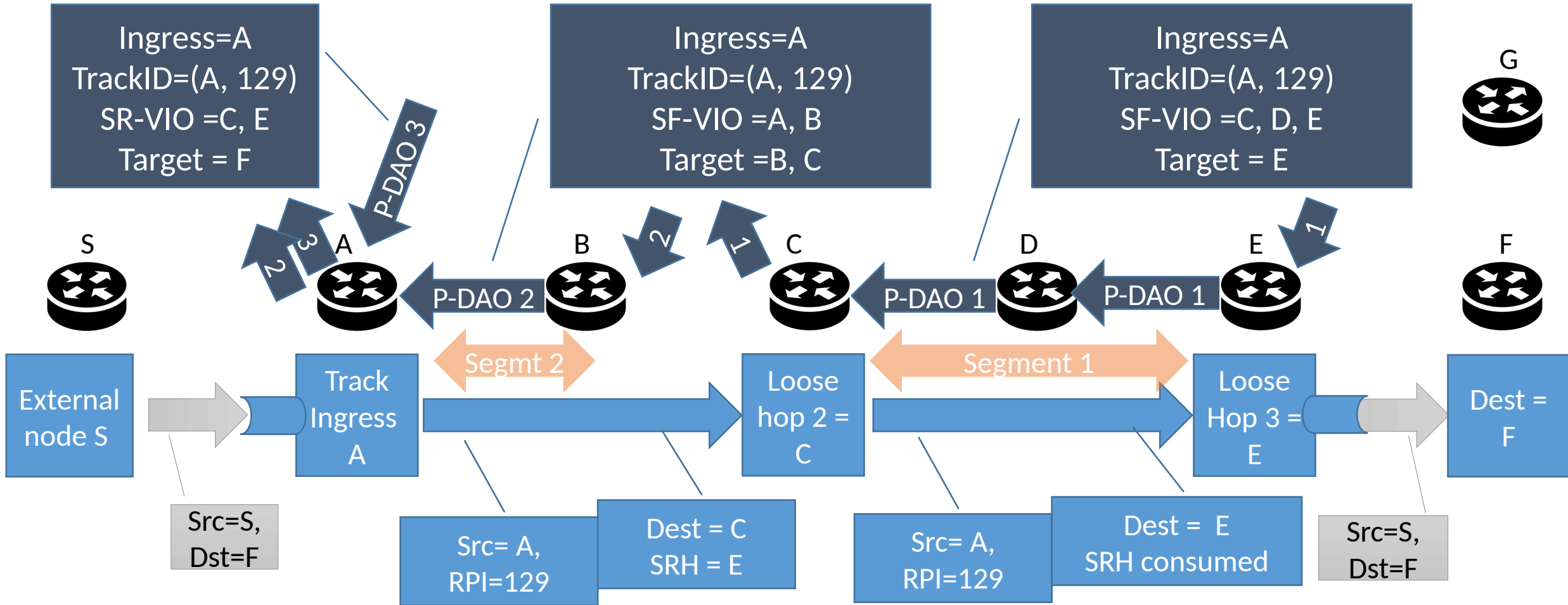

- Same as Profile 1, but for Track

Profile 6: Compress SRH in Track with NSM Tracks (Recursive?)

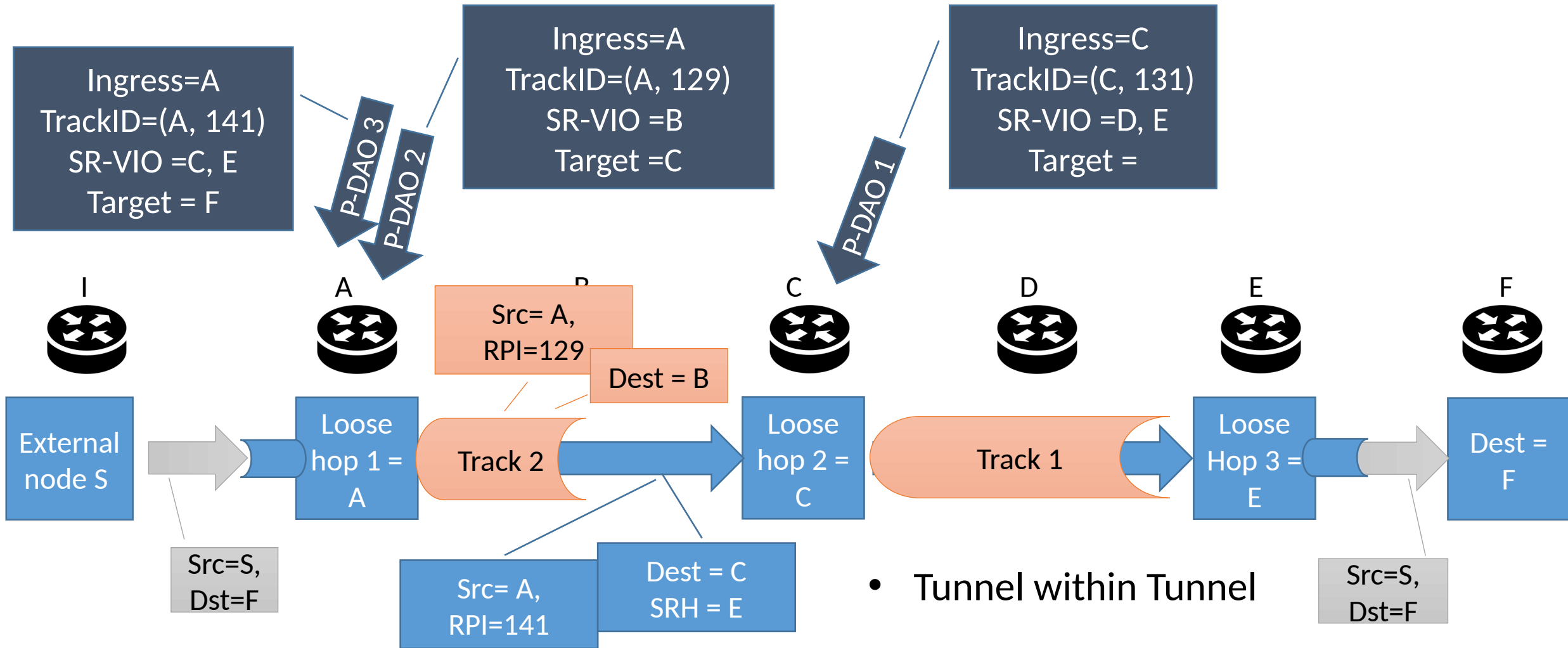

Topology awareness

- Initially out of scope
- Now we have non storing mode + Sibling info option
 - Acronym conflict with RPL's Solicited Information Option
- Needed for profiles ≥ 3
- Which sibling to advertise is still out of scope
 - Separate draft?

Huimin's comments / suggestions

- Lifetime unit: ReqLifetime, Track lifetime, and Segment Lifetime are defined as 8 bits. And their lifetime Unit is obtained from the DODAG configuration option. It will lead to inflexibility as all tracks in the PAN use the same lifetime unit. We propose to define lifetime unit separately for each track (for example adding a 2-bit flag to indicate second, minute, hour, day). Details can be discussed later.
- Now the TrackID has the same meaning as Local RplInstanceId. How does a node judge whether the received message is a P-DAO message or Local RPL instance DAO message? Is it possible to define a flag in the P-DAO message?
- The P-DAO track/segment is single-directional. I suggest to add the possibility for creating bi-directional segments/tracks. We can add a flag in the PDR message to indicate the requested track is single-directional or bi-directional.
- I suggest to add a flow of message exchanges for “PDR, PDR-ACK, P-DAO, P-DAO ACK” in the draft.

Other to be done

- Loop avoidance
- Who sends PDR? If it was destination, then it could select the trackID from its name space
- ND (RFC 8505) to maintain sibling neighbor state
- Be very specific if Ingress and Egress are listed in VIOs
 - Ingress to indicate which source address to use
 - Egress to build the full SRH 6LoRH

RFC6550bis







Michael Richardson

main 1 branch 0 tags

Go to file

Add file

Code

 pthumbert as published	c25bd65 on Dec 4, 2020	8 commits
 README.md	Update README.md	4 months ago
 Topics	Create Topics	4 months ago
 Topics_byPascal	Create Topics_byPascal	4 months ago
 rfc6550.xml	added XML	4 months ago
 rfc6550bis.txt	as published	3 months ago
 rfc6550bis.xml	as published	3 months ago

README.md 

RFC6550bis

This repository aims to collect the topics to be covered in RPLv2/RFC6550bis

This repository relates to activities in the Internet Engineering Task Force(IETF). All material in this repository is considered Contributions to the IETF Standards Process, as defined in the intellectual property policies of IETF currently designated as BCP 78 (<https://www.rfc-editor.org/info/bcp78>), BCP 79 (<https://www.rfc-editor.org/info/bcp79>) and the IETF Trust Legal Provisions (TLP) Relating to IETF Documents (<http://trustee.ietf.org/trust-legal-provisions.html>).

Any edit, commit, pull-request, comment or other change made to this repository constitutes Contributions to the IETF Standards Process. You agree to comply with all applicable IETF policies and procedures, including, BCP 78, 79, the TLP, and the TLP rules regarding code components (e.g. being subject to a Simplified BSD License) in Contributions.

IETF Policies - Please read the note-well <https://www.ietf.org/about/note-well/> before participation.

Controlling Secure Network Enrollment in RPL Networks

draft-ietf-roll-enrollment-priority-04

Rahul Arvind Jadhav <rahul.ietf@gmail.com>

Pascal Thubert <pthubert@cisco.com>

Huimin She <hushe@cisco.com>

[Michael Richardson mcr+ietf@sandelman.ca](mailto:mcr+ietf@sandelman.ca)

IETF110, March 2021

Status of Document

- Adopted March 2020
- Merged with draft-hushe-roll-dodag-metric after virtual interim meeting January 2021.
- Version -04 posted with merged document

version -04

This document describes an RPL DIO option that can be used to announce a minimum enrollment priority. Each potential _Join Proxy_ would use this value as a base on which to add values relating to local conditions. As explained in [I-D.ietf-6tisch-enrollment-enhanced-beacon], higher values decrease the likelihood of an unenrolled node sending enrollment traffic via this path.

This document describes a RPL DIO option that can be used to announce a minimum enrollment priority. The minimum priority expresses the (lack of) willingness by the RPL DODAG globally to accept new joins. It may derive from multiple constraining factors, e.g., the size of the DODAG, the occupancy of the bandwidth at the Root, the memory capacity at the DODAG Root, or an administrative decision.

Each potential _Join Proxy_ would use this value as a base on which to add values relating to local conditions such as its Rank and number of pending joins, which would degrade even further the willingness to take more joins.

When a RPL domain is composed of multiple DODAGs, nodes at the edge of 2 DODAGs may not only join either DODAG but also move from one to the other in order to keep their relative sizes balanced. For this, the approximate knowledge of size of the DODAG is an essential metric. Depending on the network policy, the size of the DODAG may or may not affect the minimum enrollment priority. It would be limiting its value to enforce that one is proportional to the other. This is why the current size of the DODAG is advertised separately in the new option.

As explained in [I-D.ietf-6tisch-enrollment-enhanced-beacon], higher values decrease the likelihood of an unenrolled node sending enrollment traffic via this path.

Version -04 changes 2

This document describes an RPL DIO option that can be used to announce a minimum enrollment priority. Each potential _Join Proxy_ would this value as a base on which to add values relating to local conditions. As explained in

```
0 1 2 3 4 5 6 7 8 9 0 1 2 3 4 5 6 7 8 9 0 1 2 3 4
+-+--+--+--+--+--+--+--+--+--+--+--+--+--+--+--+--+
| Type = TBD01|Opt Length = 1|R| min. priority |
+-+--+--+--+--+--+--+--+--+--+--+--+--+--+--+--+
```

This document describes a RPL DIO option that can be used to announce a minimum enrollment priority. The minimum priority expresses the (lack of) willingness by the RPL DODAG globally to accept new joins. It may derive from multiple constraining factors, e.g., the size of

```
0 1 2 3 4 5 6 7 8 9 0 1 2 3 4 5 6 7 8 9 0 1 2 3 4 5 6 7 8 9 0 1
+-+--+--+--+--+--+--+--+--+--+--+--+--+--+--+--+--+--+--+--+--+--+
| Type          |Opt Length = 3 | exp | DODAG_Size          |
+-+--+--+--+--+--+--+--+--+--+--+--+--+--+--+--+--+--+--+--+--+--+
|R| min priority|
+-+--+--+--+--+
```

Type To be assigned by IANA
exp a 4 bit unsigned integer, indicating the power of 2 that defines the unit of the DODAG Size, such that $(\text{unit}=2^{\text{exp}})$.

DODAG Size a 12 bit unsigned integer, expressing the size of the DODAG in units that depend on the exp field. The size of the DODAG is computed as $(\text{DAG_Size} \times 2^{\text{exp}})$.

the new option.

As explained in [I-D.ietf-6tisch-enrollment-enhanced-beacon], higher values decrease the likelihood of an unenrolled node sending enrollment traffic via this path.

Questions?

draft-ietf-roll-enrollment-priority-04



Example enrollment priority

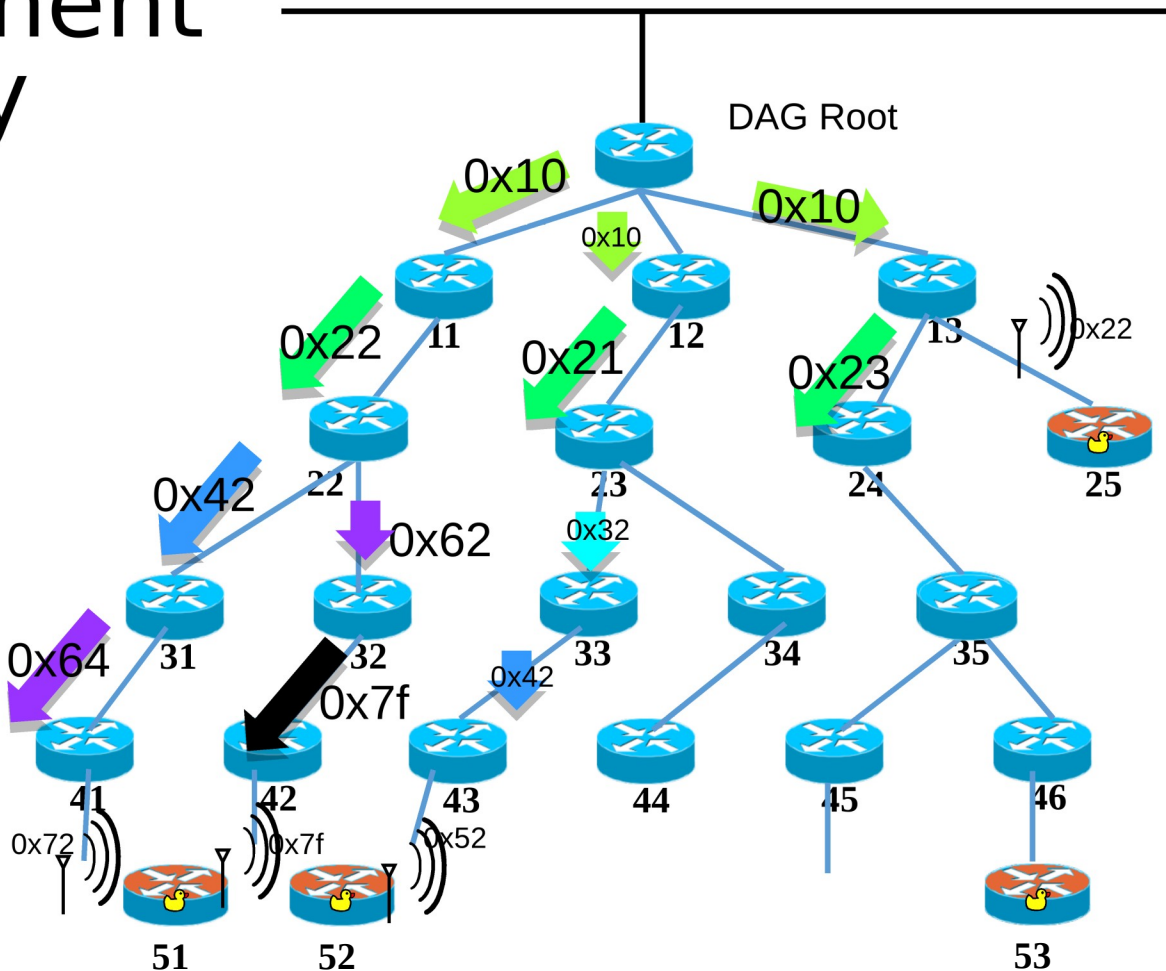

Enhanced Beacons
DIOs

base diagram from PThubert

With impaired node (24)

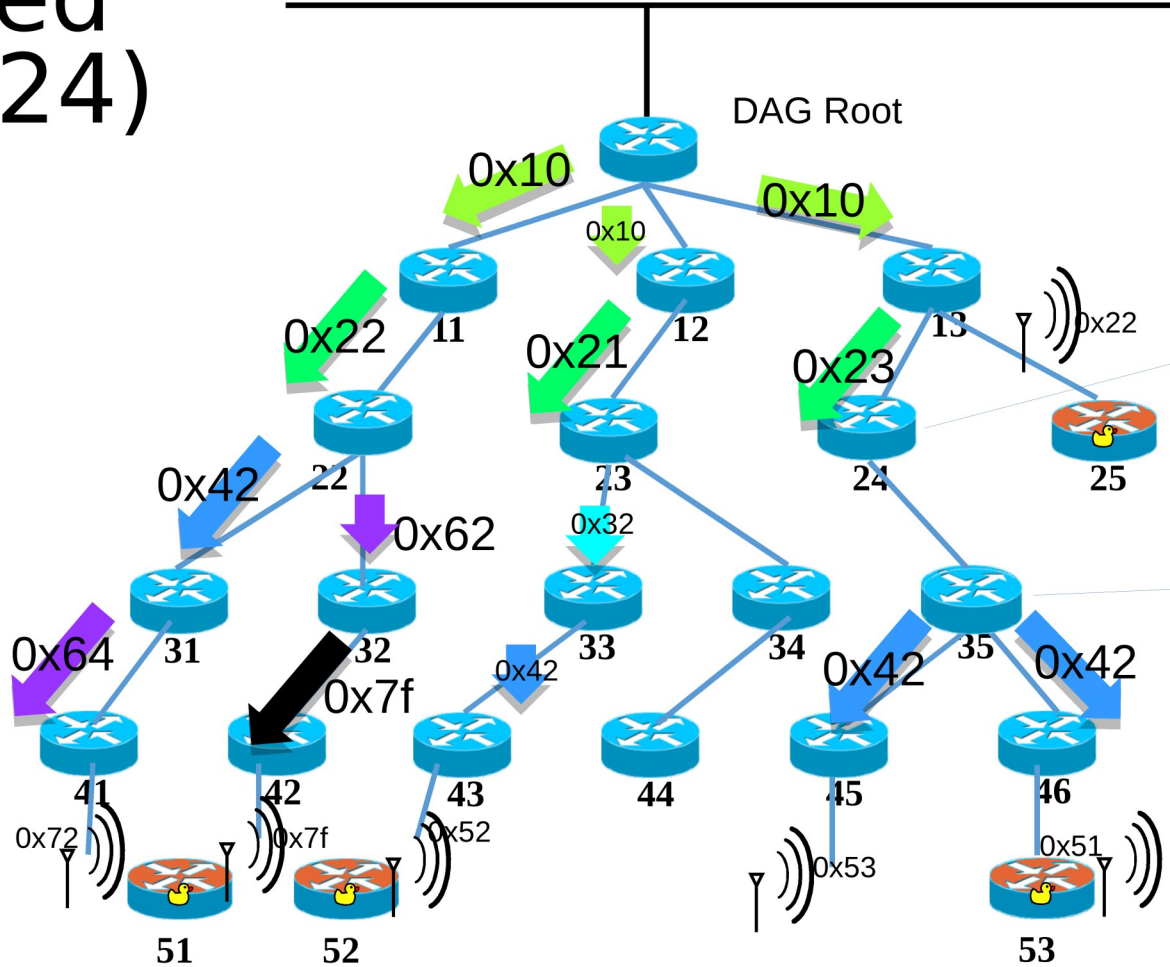

Enhanced Beacons
DIOs

Does not support this option

implied 0x40

Capabilities Status

draft-ietf-roll-capabilities
ROLL IETF 110

What does the document contain?

- Capability Options that can be carried in any RPL messages
- Two specific capabilities
 - Capability Indicator flags
 - Routing Resource Capability
- Capability Query/Response signalling
- Guidelines for defining new capabilities

MUSTs:

- Handling of Capabilities MUST be supported if the network uses MOPex [I-D.ietf-roll-mopex].

Capability Options

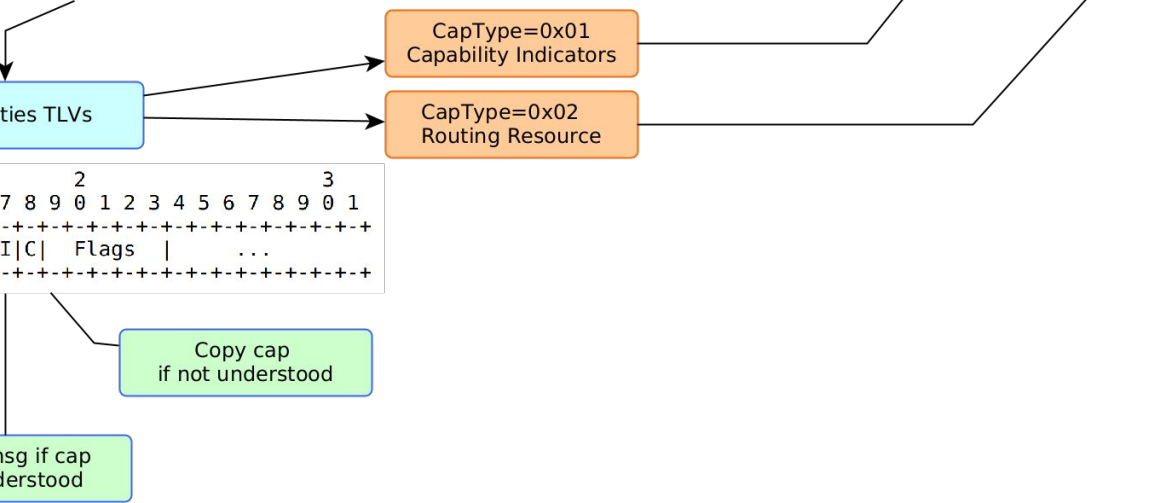
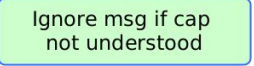
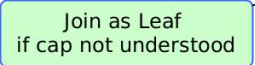
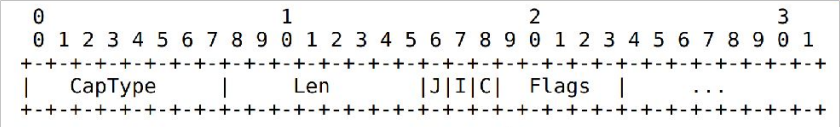
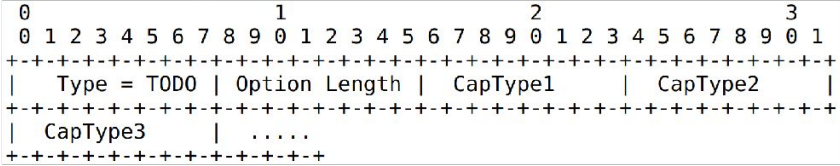
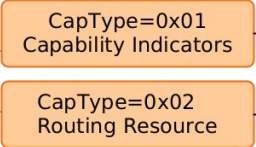
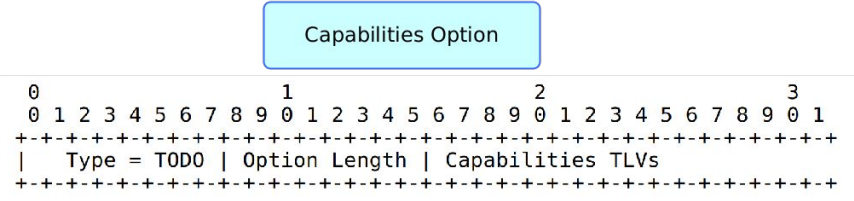

Capability Query/Response

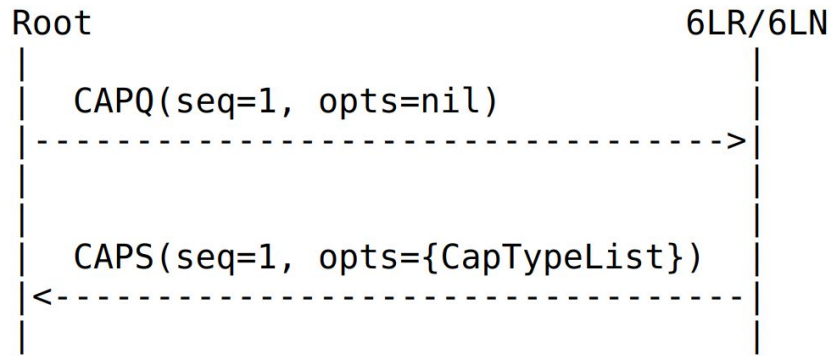

Figure 8: Query supported Cap Types

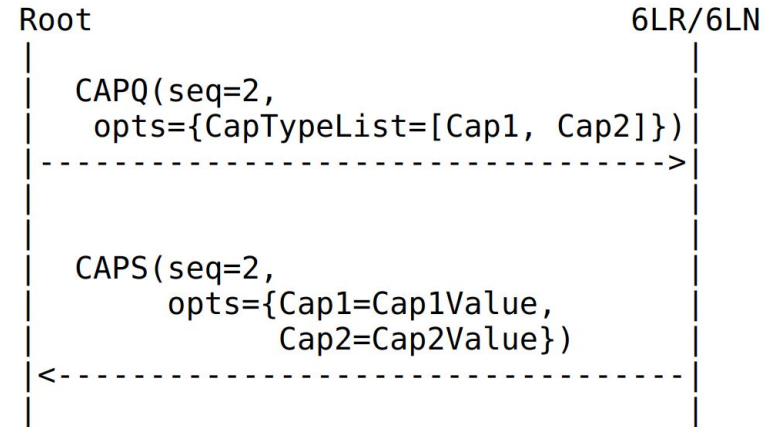

Figure 9: Query specific Cap Set

And the corresponding secure messages.

MOPex Status

draft-ietf-roll-mopex

What does the document contain?

- Defines MOPex
 - Base MOP == 7, expect MOPex control option to be present
- Explains handling of MOPex under various conditions
- Extending RPL control options

Extending RPL Control Options

Problem Statement: How to handle unknown RPL Control Options?

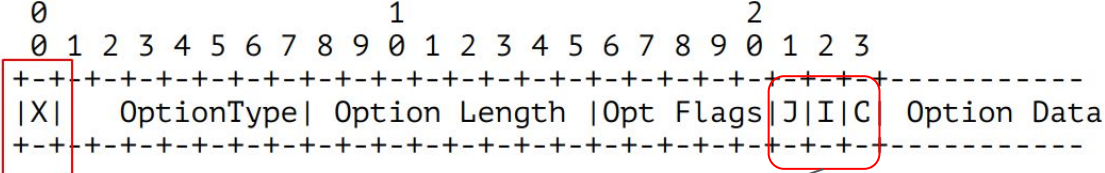

Figure 2: Extended RPL Option Format

Problem Statement: What to do if the control options is not known?

'J' bit	'C' bit	Handling
0	0	Strip off the option, and the node can join as 6LR
0	1	Copy the option, and the node can join as 6LR
1	NA	Join as 6LN

Overall Status

- No tickets open
- Received one detailed review from Dominique
- Updates were presented in the past interims too

MOPex does not have any complex handling or introduction of any new messages. Capabilities does have somewhat complex handling. MOPex is precursor for capabilities.

Can we go for LC for MOPex?

Open Floor