

Supporting leaves without northbound neighbors connecting to a fat-tree network using RIFT

draft-zwx-rift-leaf-ring-00

RIFT WG

IETF111

Sandy Zhang ZTE Corporation

Yuehua Wei ZTE Corporation

Benchong Xu ZTE Corporation

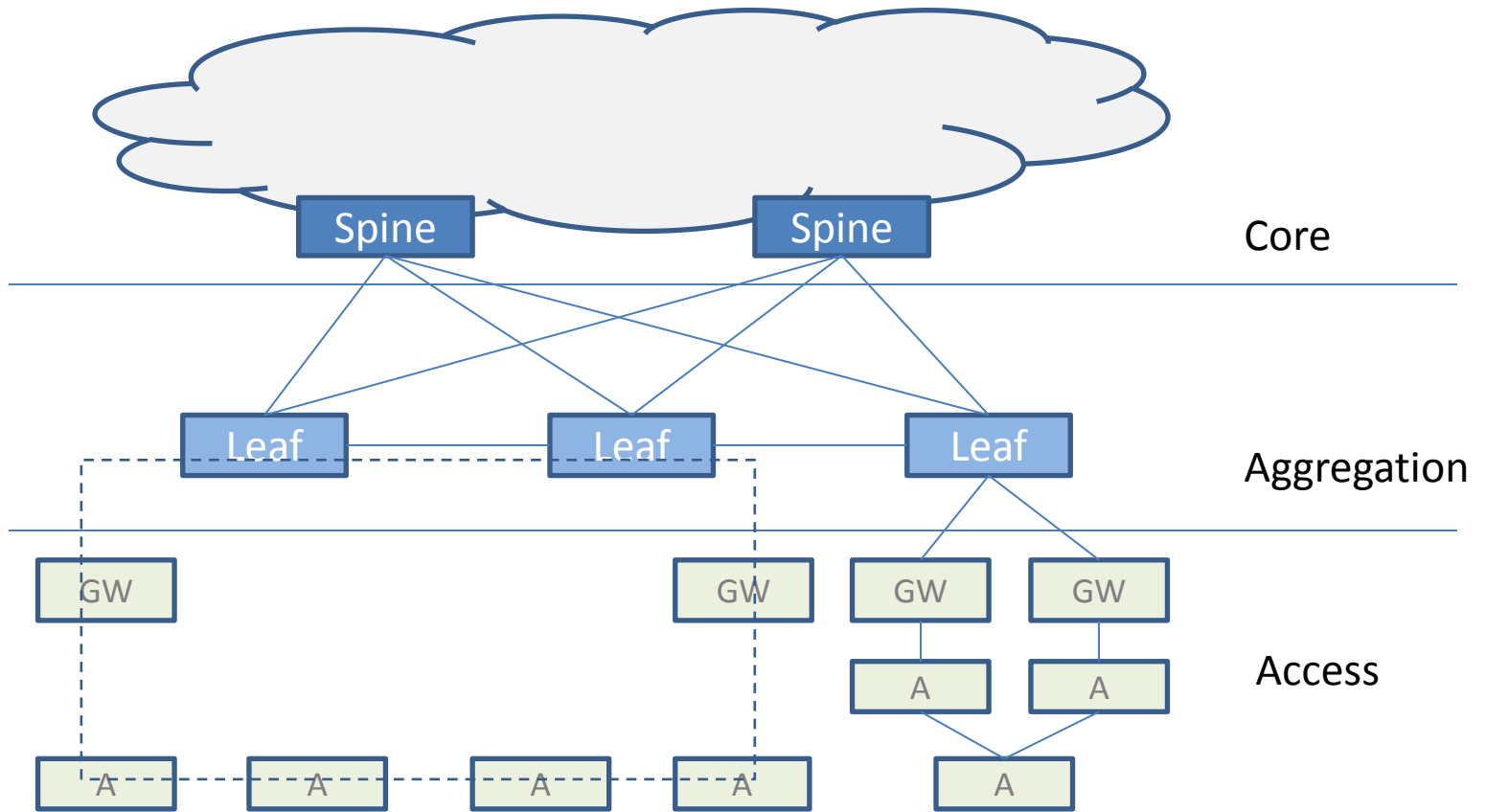

New Metro Network

Problem

- Some leaves connect to the fat-tree network by ring topology
- Some leaves have no northbound connection with spine nodes
- These leaves cannot visit with the network

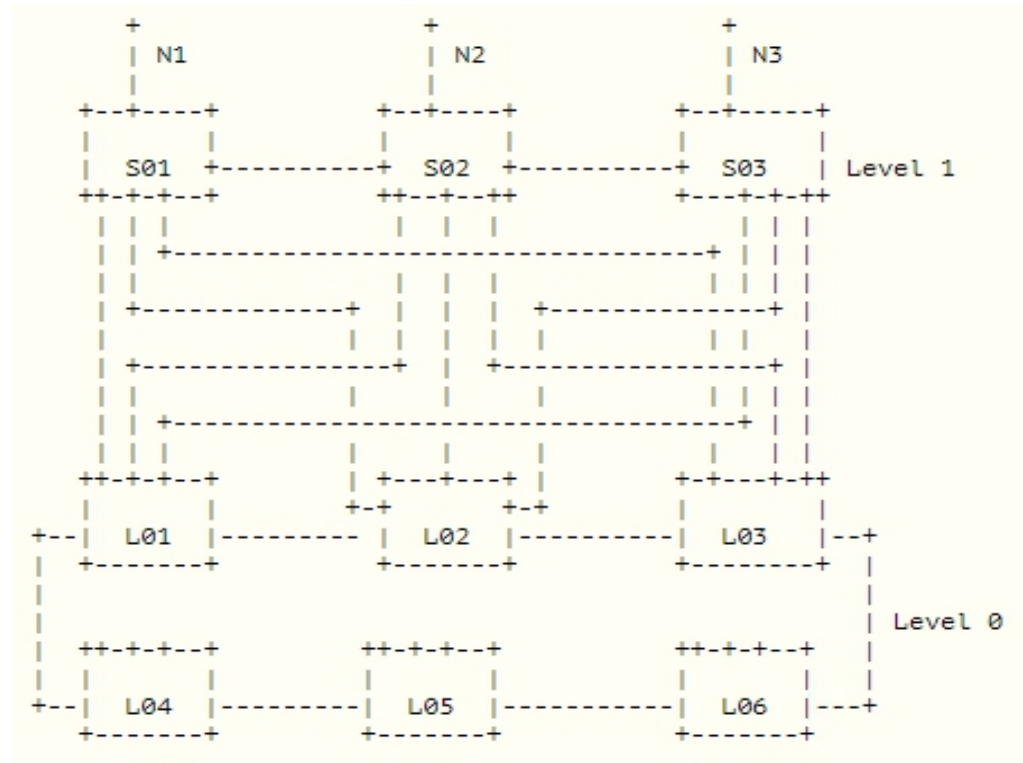

Solution

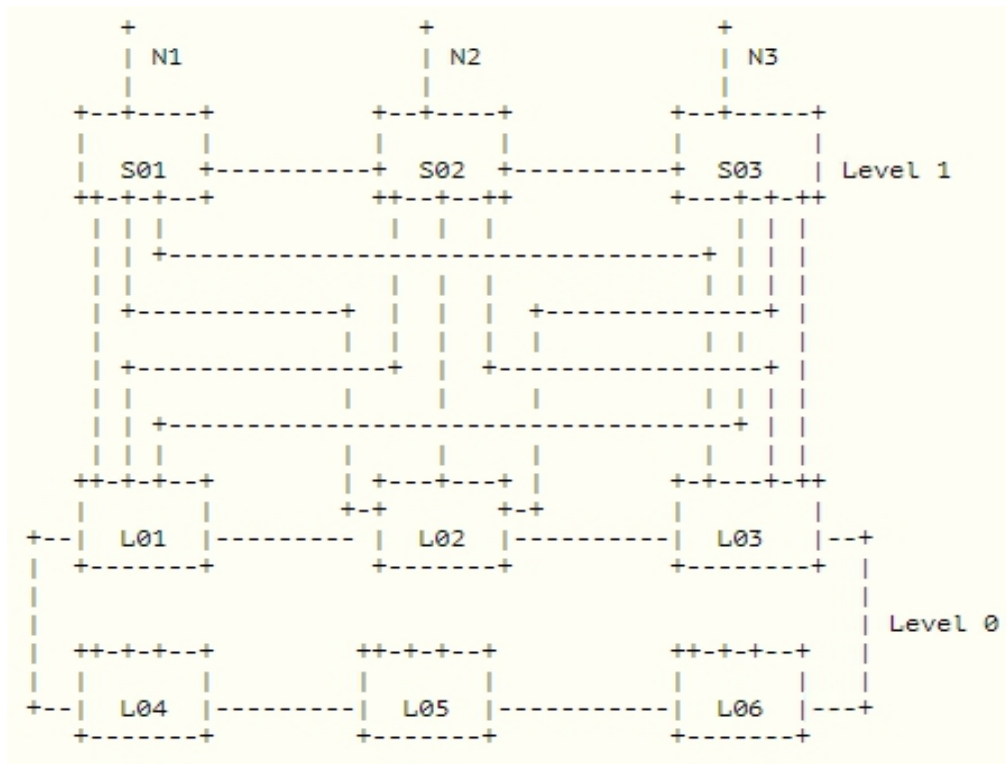

Capability advertisement

- A new link capability: leaf-transport
- Set in LIE and node TIE
- The LIE FSM will not be affected

Prefix South TIE transferring

- The leaf node without northbound neighbors MUST transfer the Prefix South TIE received from an east-west neighbor to the other east-west neighbor to the other east-west neighbor which also has no northbound connection.

Prefix North TIE transferring

- The leaf node without northbound neighbors MUST transfer the Prefix North TIE received from an east-west neighbor which has no northbound connection to the other east-west neighbor.

- Does this problem need to be solved?
- If there is any other solution?

- Any comments :-)

- Thanks!