

# Updates of APN Framework & Gap Analysis

<https://datatracker.ietf.org/doc/html/draft-li-apn-framework-04>

<https://datatracker.ietf.org/doc/html/draft-peng-apn-scope-gap-analysis-03>

Gyan Mishra/Shuping Peng  
on behalf of all the co-authors

# APN Framework Updates

- In order to better clarify what APN can enable with the introduced APN attribute compared to the existing network without APN, we illustrate how APN works through an example use case
  - ▣ A typical network service being provisioned nowadays, i.e. the Cloud Leased Line service.
- In order to make the tunnel description much easier to understand, we use the recent technology in IETF, i.e. SRv6.

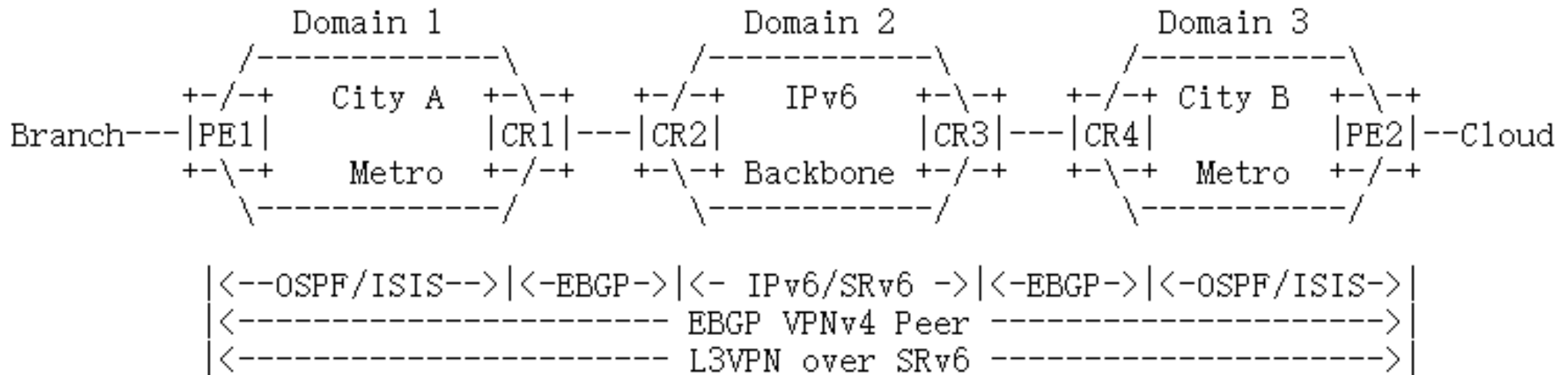

Figure 2. Reference diagram for the example use case illustration

# Example use case

- User Group and Application Group Design
- Derive the User Group and User Group at APN Edge
- Access Right Check at the edge of the backbone network
- SLA Guarantee in the backbone network
  - Network Measurement
  - Traffic Steering

	IPv6 Address	Port Number
Enterprise A/Office Audio Applications	2001:DB8:A1:A1::/64	1718, 1719
Enterprise A/Office Video Applications	2001:DB8:A1:A1::/64	5060, 5061
Enterprise A/Office Data Applications	2001:DB8:A1:A1::/64	21, 80
Enterprise A/R&D Audio Applications	2001:DB8:A1:A2::/64	1718, 1719
Enterprise A/R&D Video Applications	2001:DB8:A1:A2::/64	5060, 5061
Enterprise A/R&D Data Applications	2001:DB8:A1:A2::/64	21, 80
Enterprise A/IT Audio Applications	2001:DB8:A1:A3::/64	1718, 1719
Enterprise A/IT Video Applications	2001:DB8:A1:A3::/64	5060, 5061
Enterprise A/IT Data Applications	2001:DB8:A1:A3::/64	21, 80

```
Match:
  VPN1
  Source Address 2001:DB8:A:11::/56
Action
  Set user-group 001001001

Match:
  VPN1
  destination Address 2001:DB8:A1:A1::/64
  destination port 1718,1719
Action
  Set app-group 101001001
```

# Example use case cont.

- User Group and Application Group Design
- Derive the User Group and User Group at APN Edge
- Access Right Check at the edge of the backbone network
- SLA Guarantee in the backbone network
  - Network Measurement
  - Traffic Steering

```
Match:
  user-group 001001001
  app-group 101002001, 101002002, 101002003, 101003001, 101003002, 101003003
Action
  Deny
```

```
Match:
  user-group 001001001
  app-group 101001001, 101001002, 101001003
Action
  Permit
```

# Example use case cont..

- User Group and Application Group Design
- Derive the User Group and User Group at APN Edge
- Access Right Check at the edge of the backbone network
- SLA Guarantee in the backbone network
  - Network Measurement
  - Traffic Steering

```
Match:
  User-group 001001004 application group 101001002
  User-group 001002004 application group 101002002
  User-group 001003004 application group 101003002
Action
  Apply IOAM
```

```
Match:
  User-group 001001004 application group 101001002
  User-group 001002004 application group 101002002
  User-group 001003004 application group 101003002
Action
  Redirect SRv6 Policy 1
```

# Gap Analysis Updates – added more existing IDs

## **Detnet Flow Identification**

- The Detnet IP Flow ID is logical and there is no such Flow ID carried for Detnet, but only the **6-tuple** is directly used to identify the Detnet flows.
- Only one exceptional case, the 32-bit flow identification (FID) identifies one specific Detnet flow of redundancy protection.

## **Network Slicing Resource ID**

- The ID is used to indicate the network resources to be allocated to the network slices and it is not bound to any traffic flow.

## **Service Function Path ID**

- Service Path Identifier (SPI) uniquely identifies a Service Function Path (SFP), and it is not bound to any traffic flow.

## Gap Analysis Updates – added the comparison summary table

	ID	Identification Object	Source	Conf. node	Size
APN	APN ID	The flow that needs fine-granular services	5-tuple Layer 2	Controller	32bits 128b
iOAM	Flow ID	The flow that needs performance monitoring	-	Controller Ingress	32bits
Detnet	Flow ID (6-tuple)	The flow that needs Detnet services	-	Controller	-
Detnet	Flow ID	The redundant protection flow	-	Detnet Controller	32bits
NS	Resource ID	The network resources that are allocated to network slices	-	Controller	32bits
SFC	SPI	The SF Path	-	Controller	24bits
SFC	Performance Policy ID	The performance policy	-	Controller	-

*Thank you!*