

MEC

Mobile Edge Computing-->
Multi-access Edge Computing

ETSI MEC – What they do

Foundation for Edge Computing created – Fully framework and function standardized solution to enable applications in distributed cloud created by ETSI MEC + 3GPP

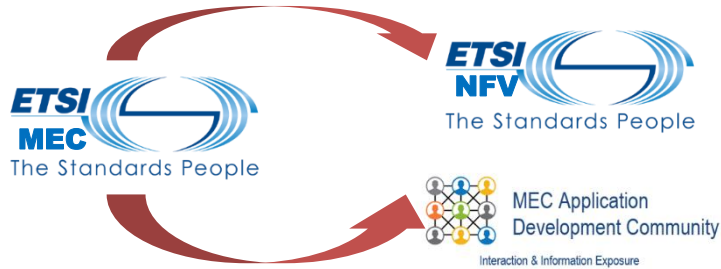

Application Life Cycle Management

Look at the new webpage with the ISG MEC Leaders and Support Team

<https://portal.etsi.org/TB-SiteMap/MEC/MEC-Leaders-and-Support-Team>

RESTful based APIs for Runtime Application Services



ETSI MEC PoC #8
Video Analytics
Nokia, Vodafone, Hutchison, See-Tec

ETSI MEC PoC #8
MEC Deployments in 4G and Evolution Towards 5G

ETSI MEC PoC #8
EVA apps for in-Car entertainment
Intel, View, Sapient, Vodafone, Huawei

119 members - Operators – Technology Vendors – IT players – Application developers



The influence of network by MEC

MEC changes the structure of networks and ends traffic locally, to provide a low latency and customized service to the user, saving bandwidth at the same time

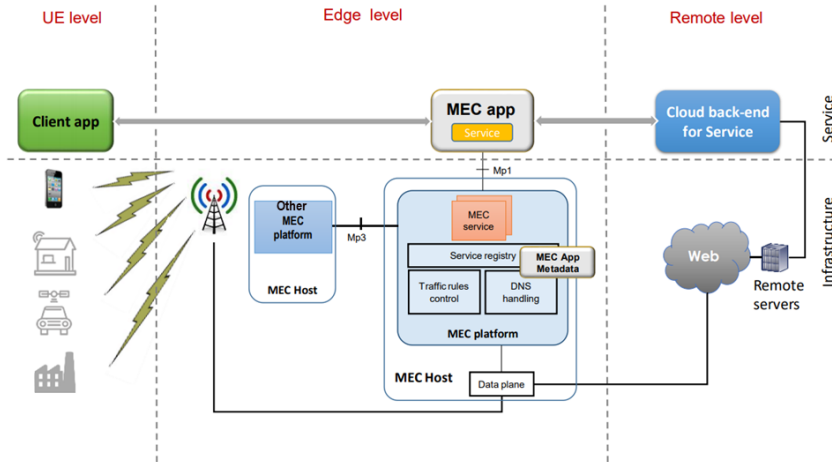

Figure 2: New application development paradigm introduced by MEC.

New issues brought to network by MEC:

How to **discover** edge by users?

How dose use **connect** to the edge?

What could the edge **provide**?

How to gurantee the **QoS**?

What if the users **move**?

Completed in 5G domain

Relation to CDN:

- CDN provides content services, while MEC can also provide more computing services.
- MEC could be deployed in CDN infrastructure but would also be expected to be closer to users.

3rd 3-year Phase of work under way

- Key overall specification
- IaaS Management APIs
- PaaS Service Exposure
- Key Studies for Future Work

- Evolution of Phase 1 and closing open items
- Addressing key Industry Segments
- Key use-cases and new requirement
 - Network Slicing (MEC 024 – published)
 - Container Support (MEC 027 – published)
- Normative work for integration with NFV
- From “Mobile” to “Multi-Access”
- **MEC integration in 5G networks (MEC 031)**
 - Developer community engagement
 - Testing and Compliance

- Preliminary activities starting now.
- Full Phase 3 work started already, while completing outstanding Phase 2 work.
- MEC as heterogeneous clouds
- **MEC deployments- in Park enterprises (MEC 038)**
- Continuing emphasis on enabling developers
- Continue to defined services that meet industry demand
- Maintain completed APIs

2015 ETSI MEC phase 1 (Completed)

2018 ETSI MEC phase 2 (Completed)

2021 ETSI MEC phase 3 (ongoing)

MEC in 5G (Completed)

- ISG MEC investigates the opportunities offered to MEC by the 5G system and its edge computing enablers



The scope includes the following

1. C-plane interactions with 5GC,
2. Functional split between MEC and 5GC wrt. API framework,
3. Organization of MEC as an AF,
4. Pertinent interactions of MEC with (R)AN

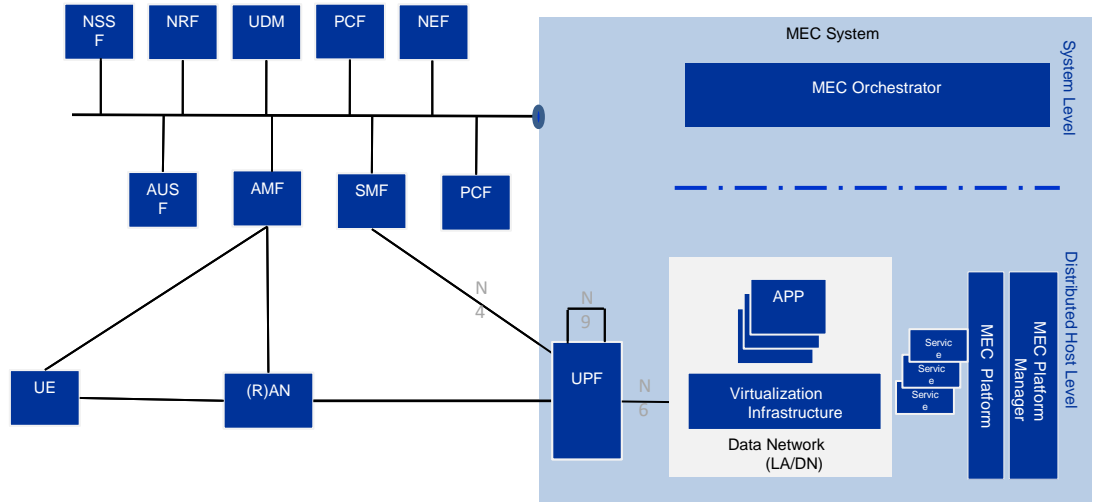

3GPP enablers for MEC – AF influence on traffic routing

MEC as an AF can provide the following to 5GC

- traffic filters identifying MEC applications deployed locally on MEC hosts in Edge Cloud
- the target UEs (one UE identified by its IP/MAC address, a group of UE, any UE)
- information about forwarding the identified traffic further e.g. references to tunnels towards MEC hosts

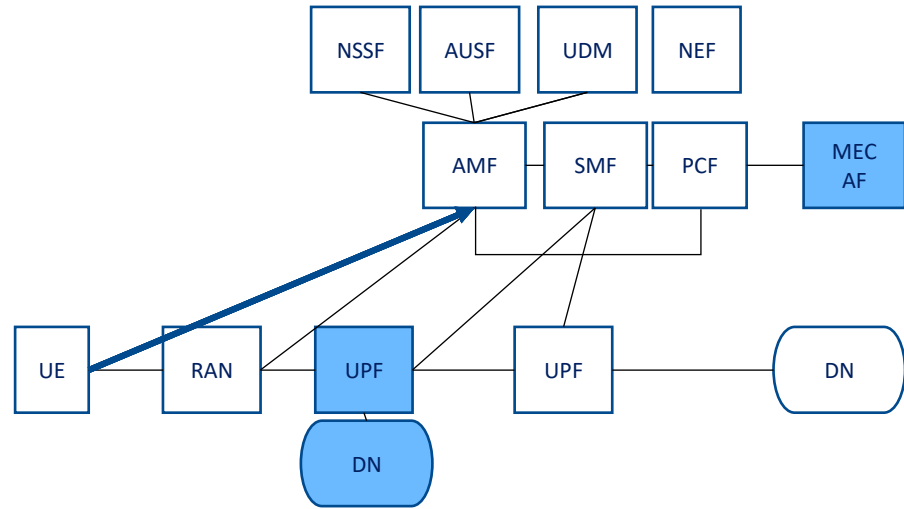

ITU-T CNC: Computing and Network Convergence

As Edge Computing has been completed in ETSI/3GPP, the work of Computing and Network Convergence is being proposed.

CNC project in ITU-T SG13

- **Related work was discussed from 2019 in SG13, and the new project CNC was set up in 2021.**
- **Computing and Network Convergence (CNC):** Emerging edge applications (AR rendering, autonomous driving) are characterized by **high mobility and other time-varying features. They may require one or more data centers to provide computing resources simultaneously in a coordinated way.** In order to support intelligent load-balancing among multiple edge sites, future networks need to support computing-aware capabilities, with unified management, control and operation in order to guarantee differentiated service experience with much higher granularity than in current networks.
- Key network requirements:
 - **Computing awareness**
 - **Multiple access capability:** To cope with the diversity of access modalities from various future computing services, it is expected to support multi-access capability tailored for computing-aware services or (virtual and physical) endpoints.
 - **Fast routing and re-routing:** support fast routing and re-routing of service traffic flows and computing tasks to the nearest or most available edge site, for real-time processing, under diverse conditions including user mobility, server load variations and other network constraints.
 - **Network protocol programmability**
 - **Flexible addressing:** to optimally address computing sites and to avoid wasting network resources.
 - **Distributed and intelligent network management for verticals**

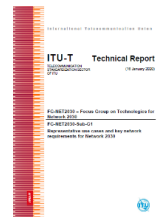

Definition and Scenarios of CNC

- Unified as CNC: the related work is unified as CNC by ITU SG13 , in November meeting.
- **Three on-going work items:** requirements of CNC, Qos requirements and framework of CNC, management requirements and framework of CNC
- **Definition of CNC:** computing and network resource joint optimization based on the awareness, control and management over network and computing resources.
- **Scenarios:**
 - Scenario 1: Low latency and high computing requirements, e.g. AR/VR
 - Scenario 2: Service consistence e.g. Connected Cars
 - Scenario 3: Huge Scientific Data Applications



TD953: ITU-T Y.IMT2020-CNC-req: "Requirements of computing and network convergence for IMT-2020 and beyond

TD 935: ITU-T Y.IMT2020-QoS-CNC-req: "QoS assurance-related requirements and framework for computing and network convergence supported by IMT-2020 and beyond"

TD 948: ITU-T Y.M&O-CNC-fra: "Management and orchestration related requirements and framework for computing and network convergence supported by IMT-2020 and beyond"

Potential framework of CNC

- CNC provides the capability to jointly schedule service requests to optimal service endpoints along **network path**, and guarantee the services quality for end users, aiming at the support of use cases including, but not limited to, those with needs for **extreme low latency, high computing, high mobility, dynamic services, and energy savings**.
- **New requirements of IMT-2020 and beyond:** including, but not limited to, **awareness of network and computing resources**, awareness and mapping of service requirements, joint scheduling of network and computing resources, unified management of network and computing resources, fixed, mobile and satellite convergence of computing and network, and AI/ML enabled computing and network.

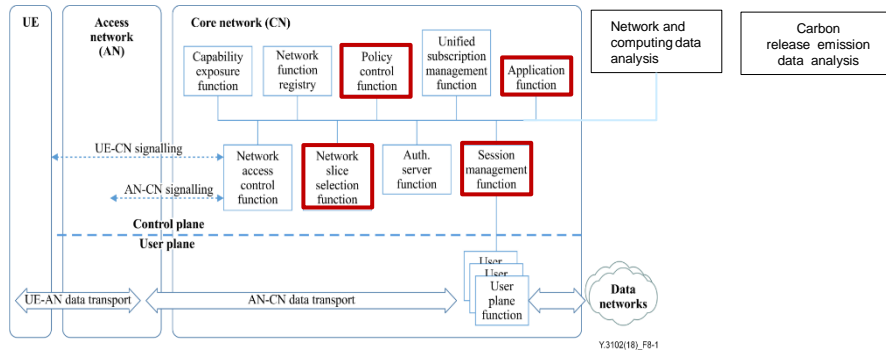

Potential enhancements toward network function of IMT-2020 network

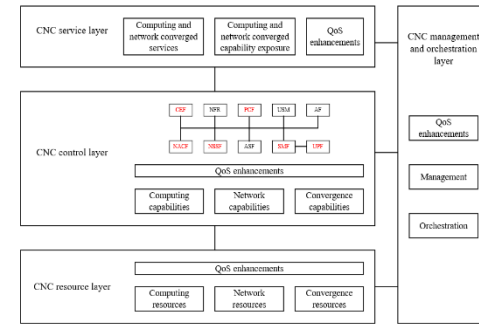

Reference model of CNC and QoS assurance

TD953: ITU-T Y.IMT2020-CNC-req: "Requirements of computing and network convergence for IMT-2020 and beyond"

TD 935: ITU-T Y.IMT2020-QoS-CNC-req: "QoS assurance-related requirements and framework for computing and network convergence supported by IMT-2020 and beyond"

TD 948: ITU-T Y.M&O-CNC-fra: "Management and orchestration related requirements and framework for computing and network convergence supported by IMT-2020 and beyond"

MEC and CNC may bring the new routing work
for IETF.