



IPv6 Neighbor Discovery Prefix Registration

draft-thubert-6lo-prefix-registration

Pascal Thubert

IETF 115

London

6LoWPAN ND (IPv6 Stateful Address Autoconfiguration)

[RFC 6775](#) (original 6LoWPAN ND)

Defines ARO for registration and DAD operations for stateful AAC



[RFC 8505](#) (Issued 11/2018)

The protocol agnostic registration for ULA/GUA for proxy ND and routing services

Analogous to a Wi-Fi association but at Layer 3: a deterministic and query-able state for all addresses

[RFC 8929](#) (Issued 11/2020)

Federates 6lo meshes over a high-speed backbone

ND proxy analogous to Wi-Fi bridging but at Layer 3

[RFC 8928](#) (Issued 11/2020)

Protects addresses against theft (Crypto ID in registration)

[draft-ietf-6lo-multicast-registration](#)

Extends RFC 8505 for multicast and anycast

[draft-thubert-6lo-unicast-lookup](#)

Provides a 6LBR on the backbone to speed up DAD and lookup

Coexistence with classical ND

[draft-thubert-6lo-prefix-registration](#)

Extends RFC 8505 for prefixes



Redistributing RFC 8505 in routing ?

- Already done for host routes with the “R” flag
 - e.g., RFC 9010 into RPL, or even RFC 8929 into IPv6 ND
 - Also draft-thubert-bess-secure-evpn-mac-signaling using BGP, or RIFT
 - Provides a host / router interface that is agnostic to the IGP beyond the router

Multi-link Subnet Routing (non- storing mode)

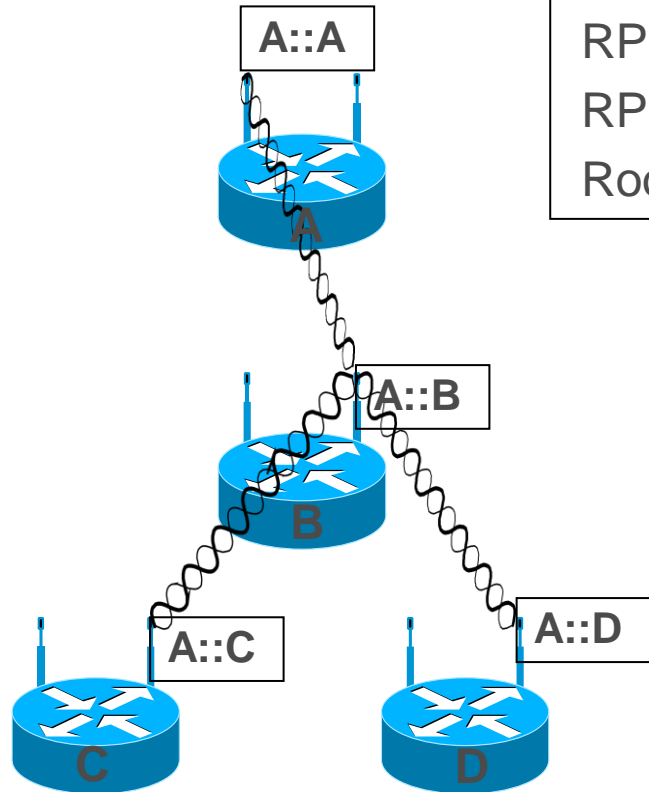

Parent is default GW, propagates root PIO (L-bit off)
 Parent Address in the PIO (with R bit)
 RPL Router autoconfigures Address from parent PIO
 RPL Router advertises Address via Parent to Root
 Root recursively builds a Routing Header back

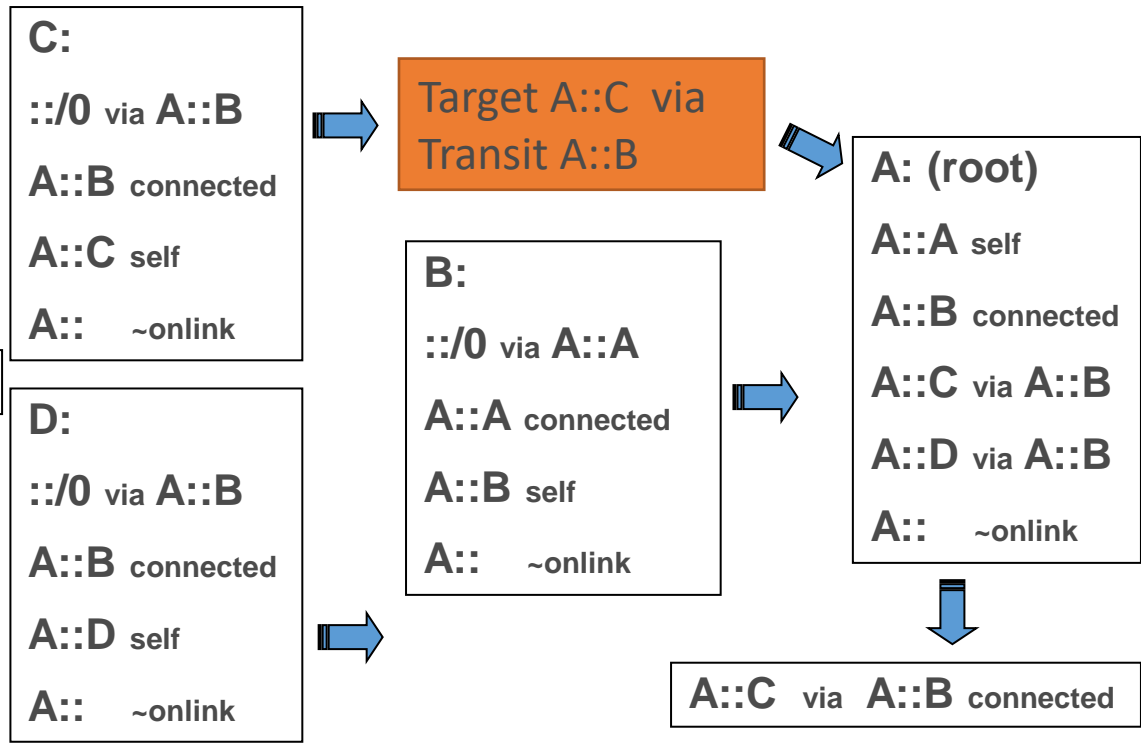

RFC 9010 (RUL)

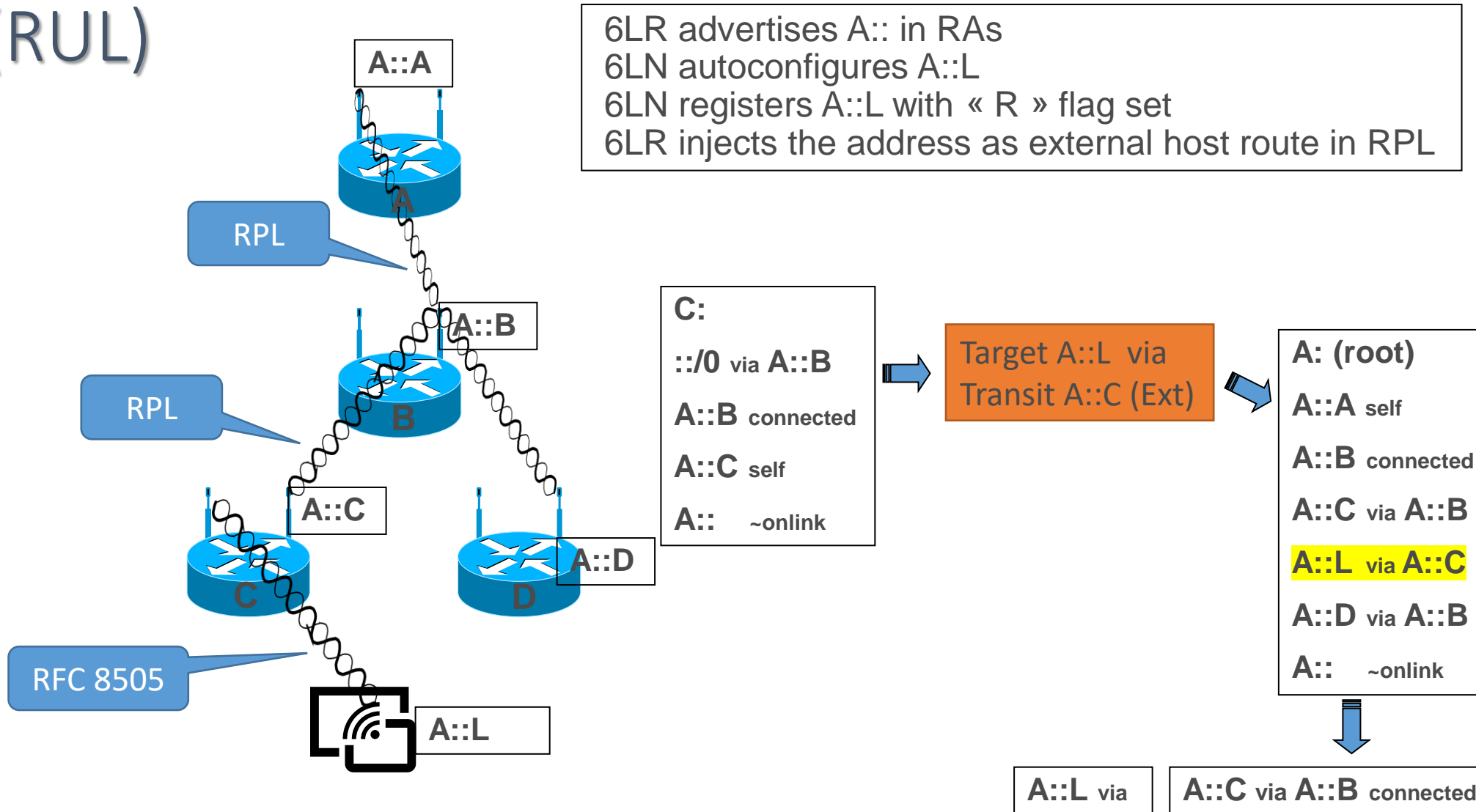

Let it be for prefixes!

- **Hosts may own prefixes -> and routers may connect to prefixes**
 - Network in Node / recursive networking
 - Kubernetes / Private IPv4 realms
 - Directly connected (no routing)

Owned prefix routing (non-storing mode)

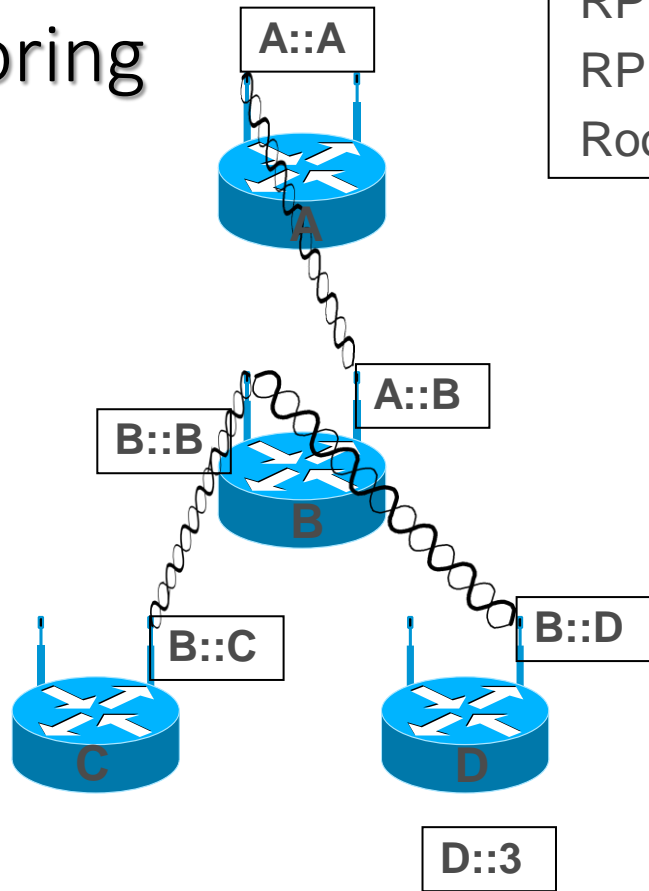

Parent is default GW, advertizes owned PIO (L bit on)
 RPL Router autoconfigures Address from parent PIO
 RPL Router advertises Prefix via Address to Root
 Root recursively builds a Routing Header back

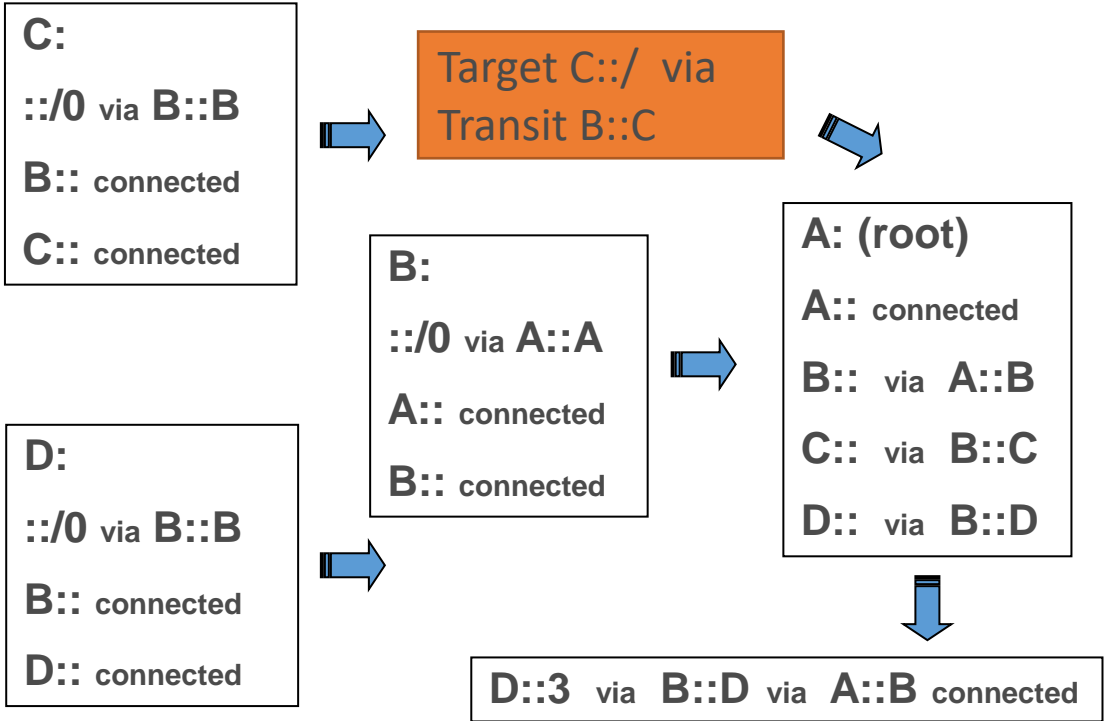

Owned prefix routing (non-storing mode)

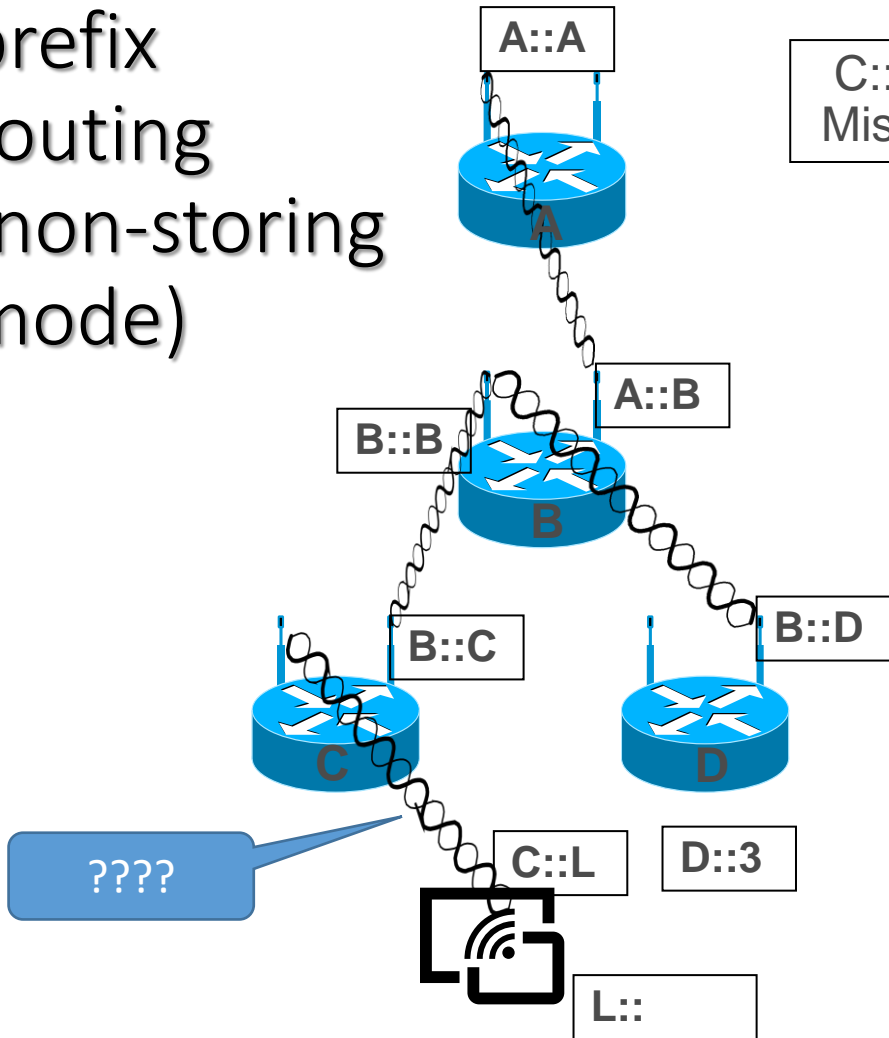

C::L is reachable but L:: is not
Missing equivalent of RFC 8505/9010 for prefixes

C:
::/0 via B::B
B:: connected
C:: connected

Target C::/ via Transit B::C

A: (root)
A:: connected
B:: via A::B
C:: via B::C
D:: via B::D

L:: unreachable

C::L via B::C via A::B connected

Non LLN (SNAC) Use case 1: Shared Link

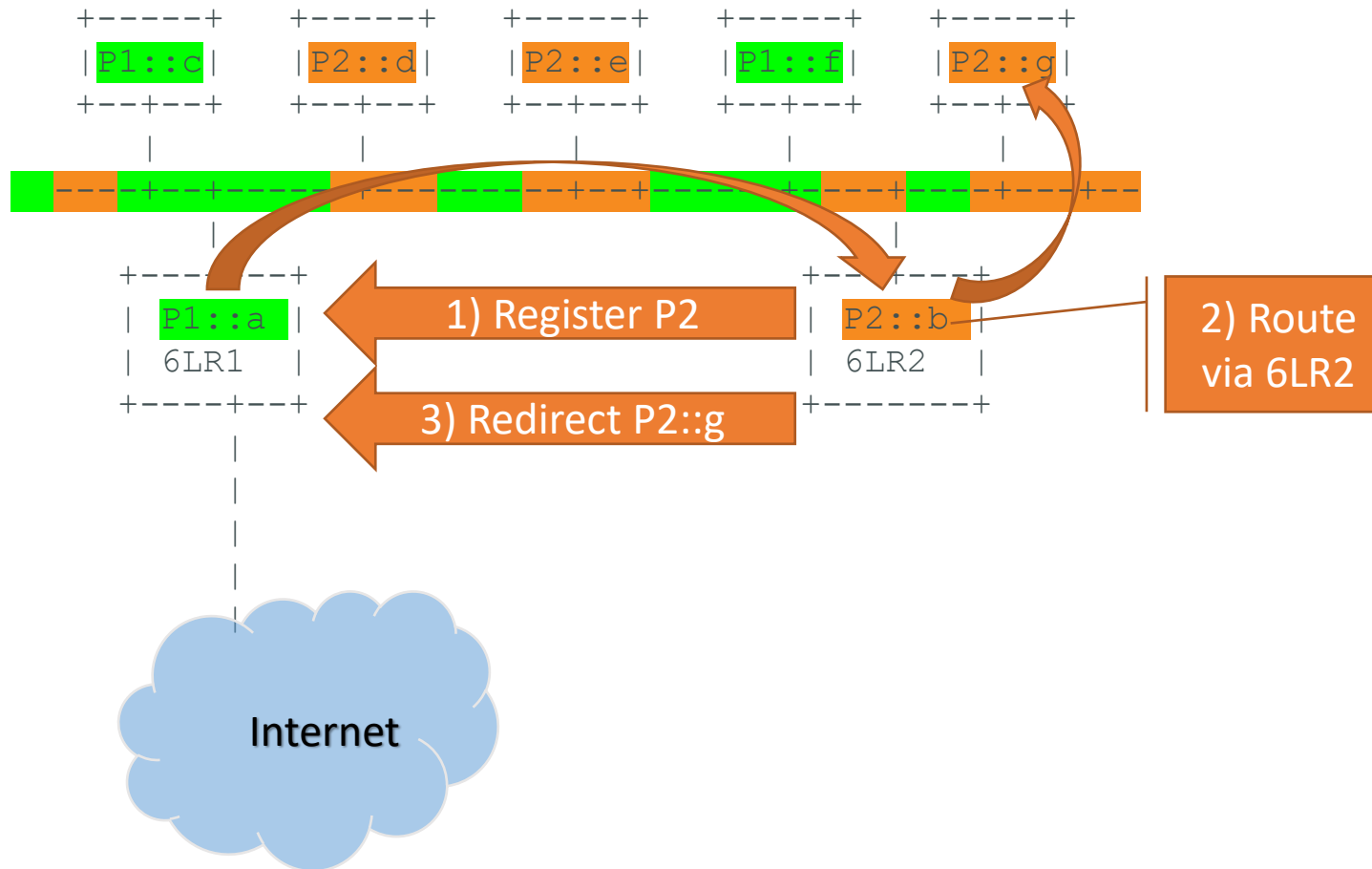

Non LLN (SNAC) Use case 2: Hub and Stubs

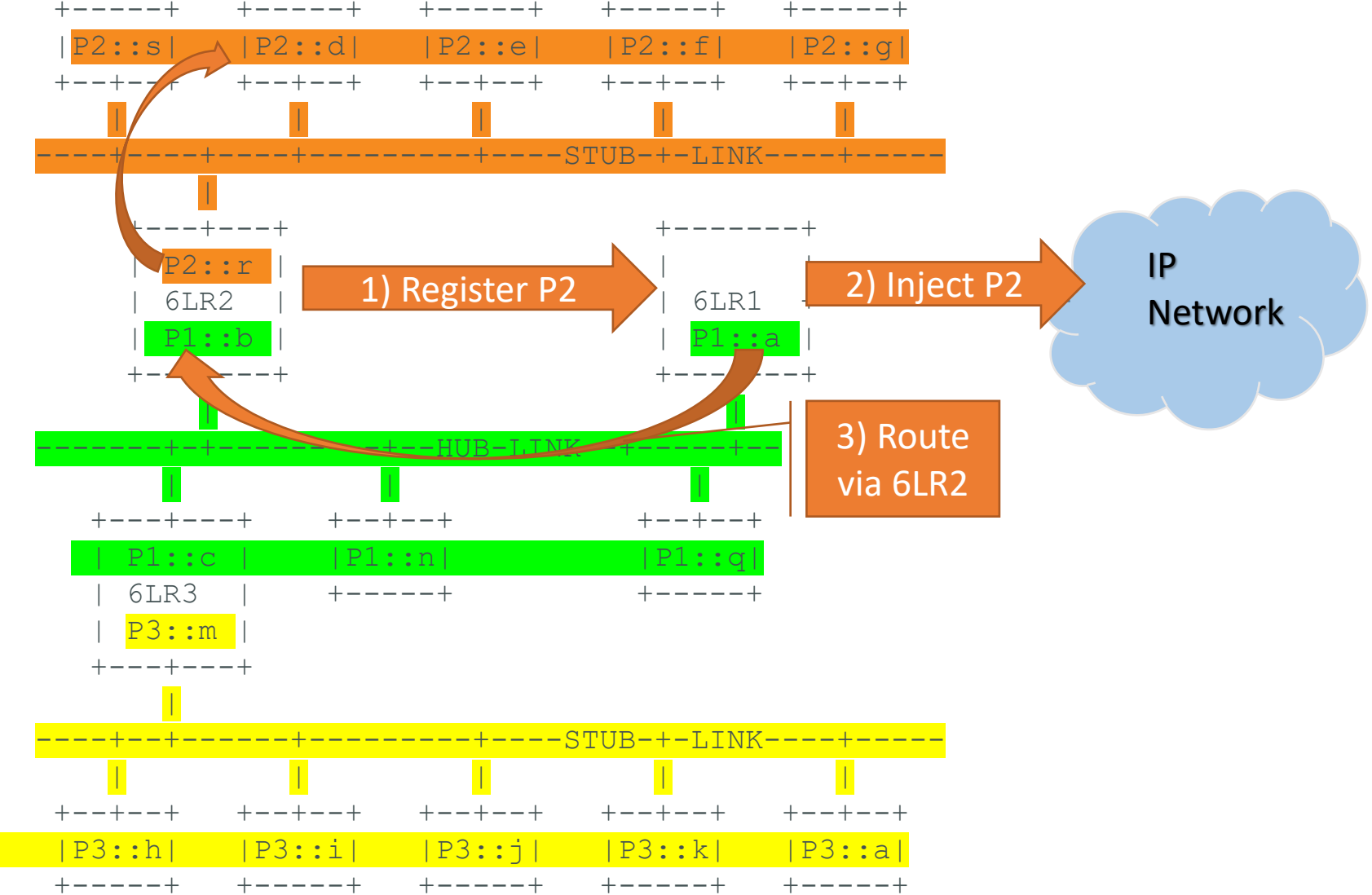

What becomes of DAD?

- **Need to consider prefix aggregation and nesting**
 - Provisioned Mobile Networks should be unique
 - Auto-allocation?

How would that work?

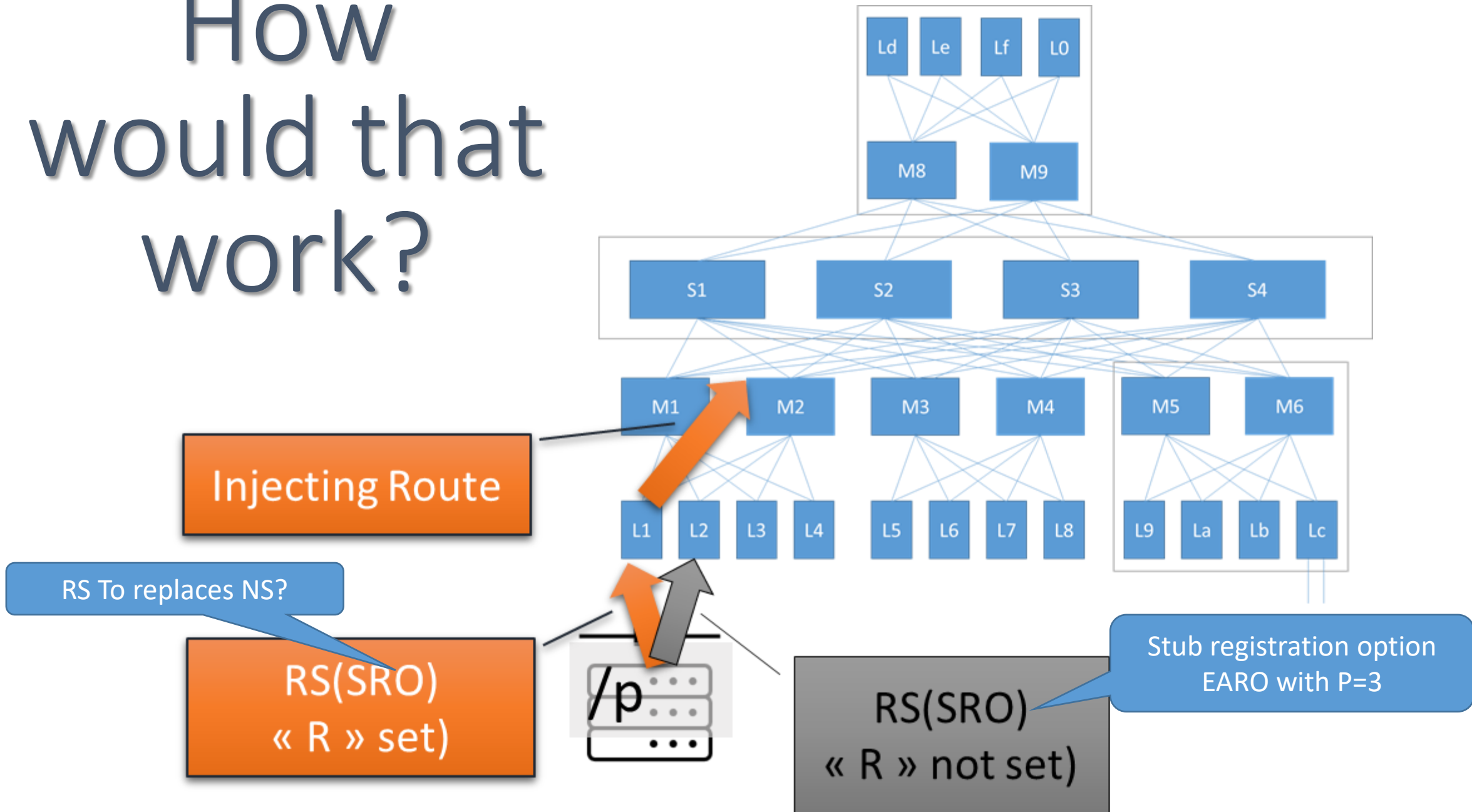

Extending the P field

- P is a 2-bits field in EARO, DAR, and RTO
- Defined the Multicast Address Registration draft

Value	Meaning	Reference
00	Registration for a Unicast Address	mcast RFC
01	Registration for a Multicast Address	mcast RFC
10	Registration for an Anycast Address	mcast RFC
11	Unassigned	mcast RFC
11	Registration for a prefix	This RFC

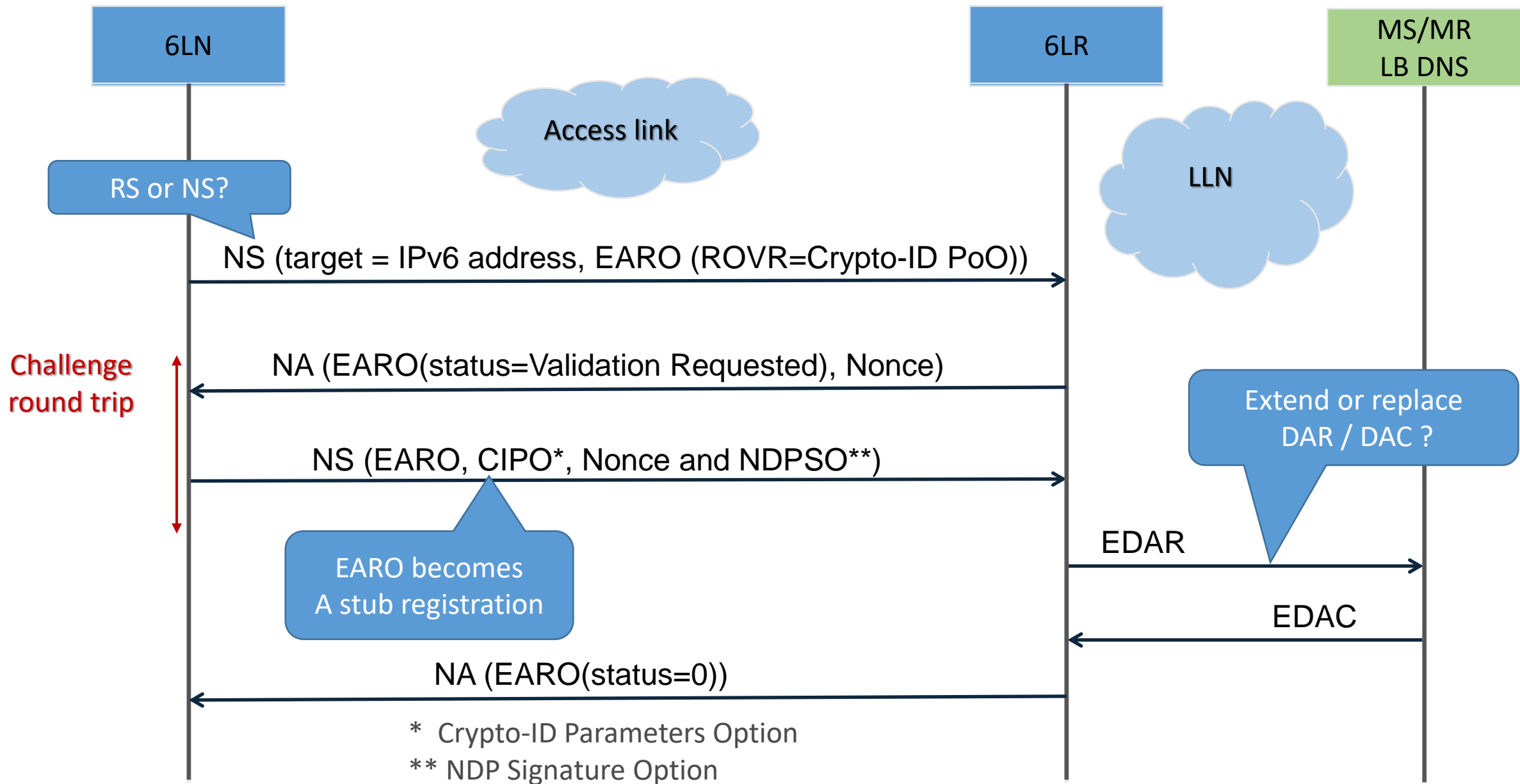

Non LLN (cloud) Use case 3: LISP/EVPN

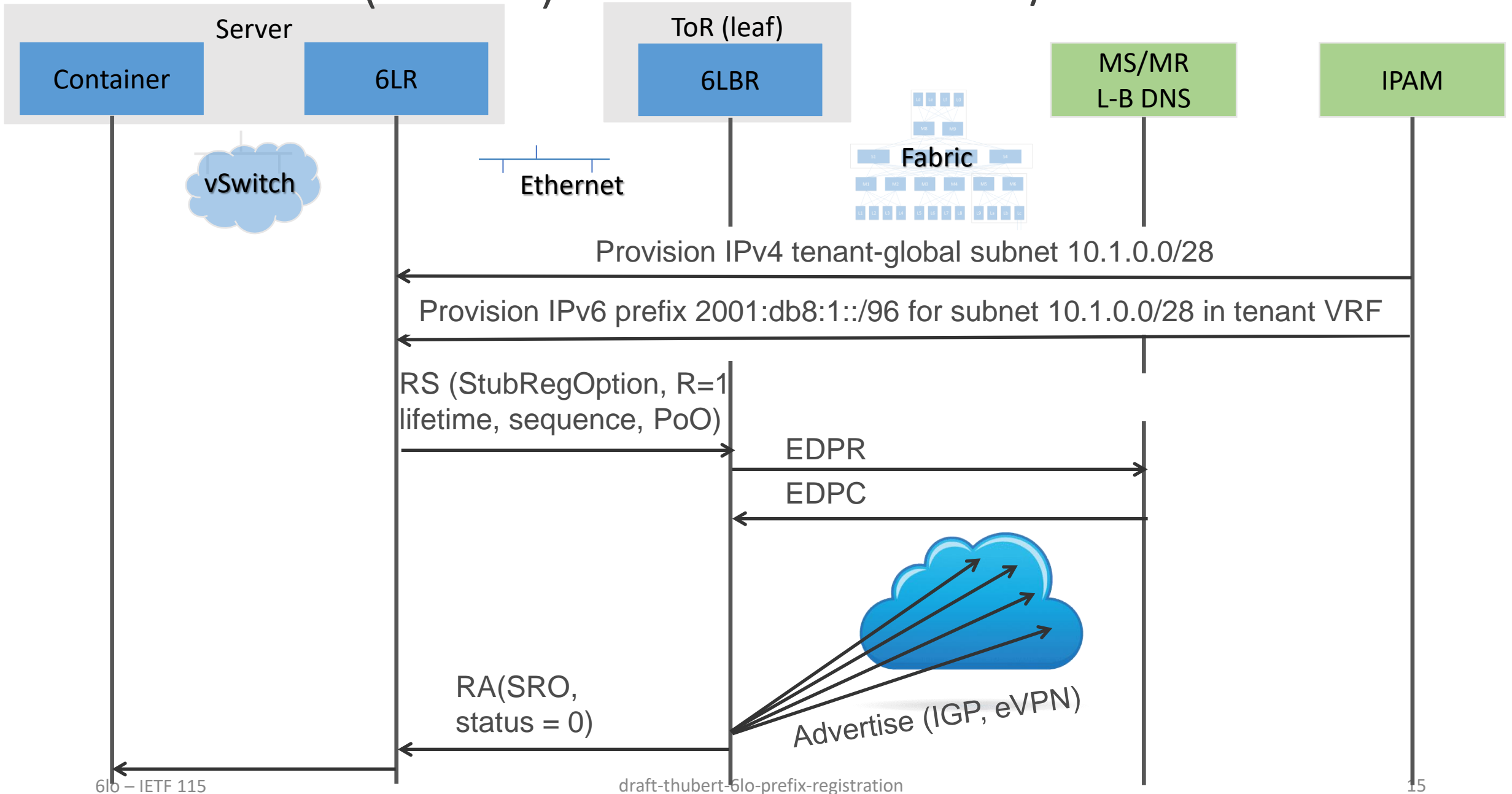

Could do's

- Adding stub prefix advertisement vs. host today
 - Indicate prefix type e.g., a /96 to embed an IPv4 address
 - Proof of ownership (PoO) per RFC 8928
- Adding policy / ACLs
 - Signal partial micro-segmentation (offload), who can talk to me
- Adding preference to influence load balancing
 - worker capacity (clusters / containers)
 - Access bandwidth /
 - multihoming / preferred interface / anycast
- Tenant ID / VRF ID / RPL instanceID
 - Route tags, RH

Ask

- NS vs RS?
- Name EARO with P=3 an SRO?
- Support of IPv4 with a /96 to embed an IPv4 subnet?
- Proof of ownership (PoO) per RFC 8928