

# DetNet YANG Model Extension for 5GS as a Logical DetNet Node

*(draft-jlg-detnet-5gs-00)*

**Tianji Jiang**, Peng Liu

Xuesong Geng

China Mobile

Huawei

# 5GS – A Logical DetNet Tra

- Holistically as a transparent box to external networks integrated in the DetNet domain
- Only considering the DetNet forwarding sub-layer related functions
- 5G NF TSCTSF performs mappings in the control plane between the 5GS internal NFs and the DetNet controller in the IP domain.
- Two(2) types of external-facing interfaces:
  - **DS-TT** or the (UE) device-side ports (not tagged in the picture), connects with external DetNet entities (e.g., DetNet end systems or full-fledged IP DetNet nodes/routers); could be a typical deployment for small businesses to achieve deterministic network connectivity via 5G wireless services
  - **NW-TT** or the network-side ports or NW-TT: connected via the 5G data-plane to external DetNet domain (most likely, an IP deterministic network).
- Forwarding IP packets between 5GS N6 (off UPF, NW-TT toward DN) and UE (DS-TT)

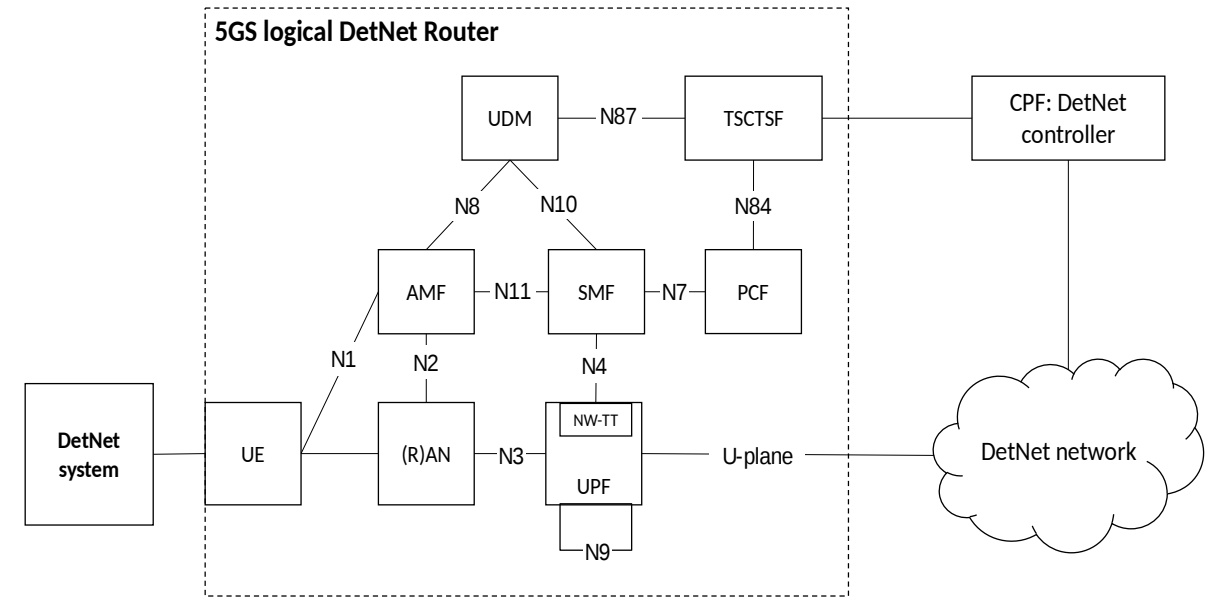

# 5GS Logical DetNet Node: Composite Architecture

- Two types of ports (DS-TT, NW-TT) and associated UP-tunnels together to support 5GS DetNet service
- Granularity of the 5GS DetNet node is per UPF for each network instance
- A 5GS DetNet node to be identified by the corresponding UPF node ID

Example: Two 5GS DetNet nodes corresponding to two UPFs:

UPF-A -> DetNet Bridge-A

UPF-B -> DetNet Bridge B

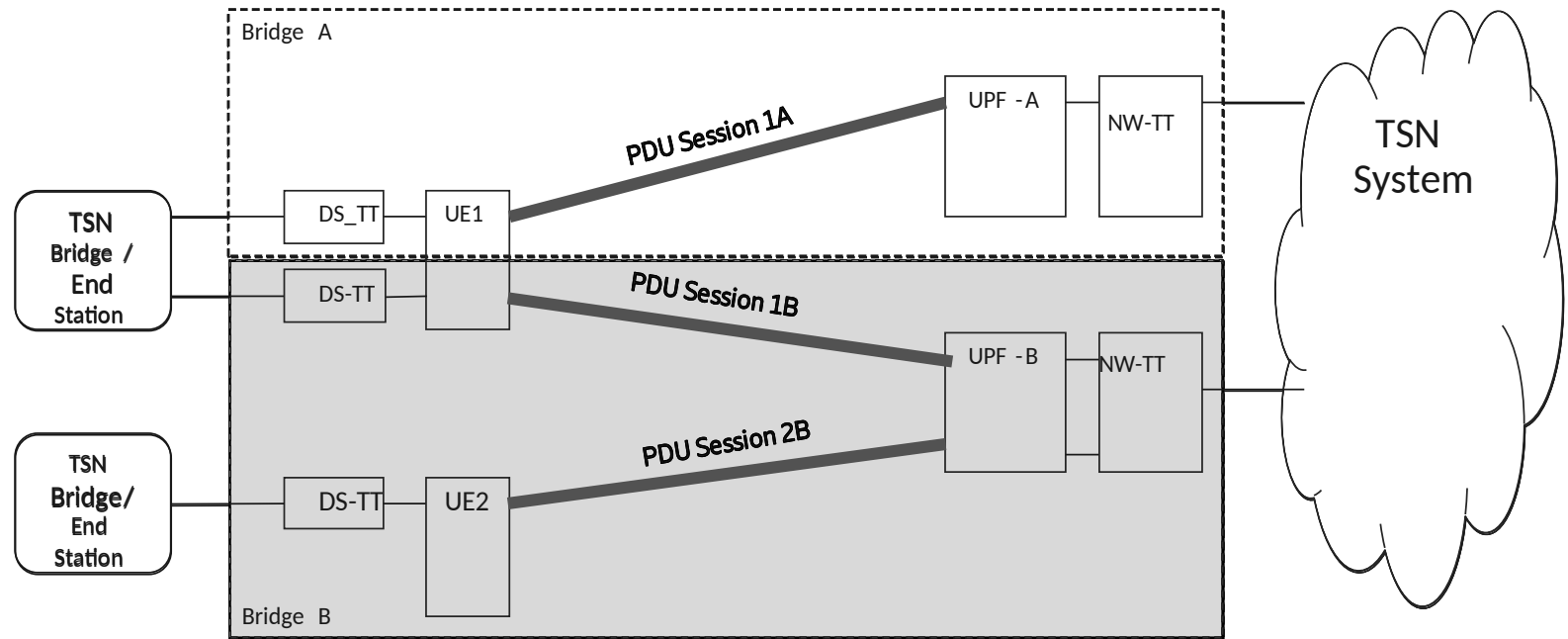

# IETF-116 Discussions on 5GS Logical DetNet Node: YANG Configuration Provisioning

Key Issues to address (2):

- 5GS logical DetNet node reporting to CPF (DetNet controller): resources, capabilities, and adjacencies
- CPF (DetNet controller) provisioning the 5GS logical node: expecting **per-(logical)-node** DetNet configuration, e.g., flow attributes, DnTrafficSpec, DnFlowReqs, etc.
  - DnReqs to 5GS mapping (approximate but incorrect): MaxLatency => PDB, and MaxLoss => PER

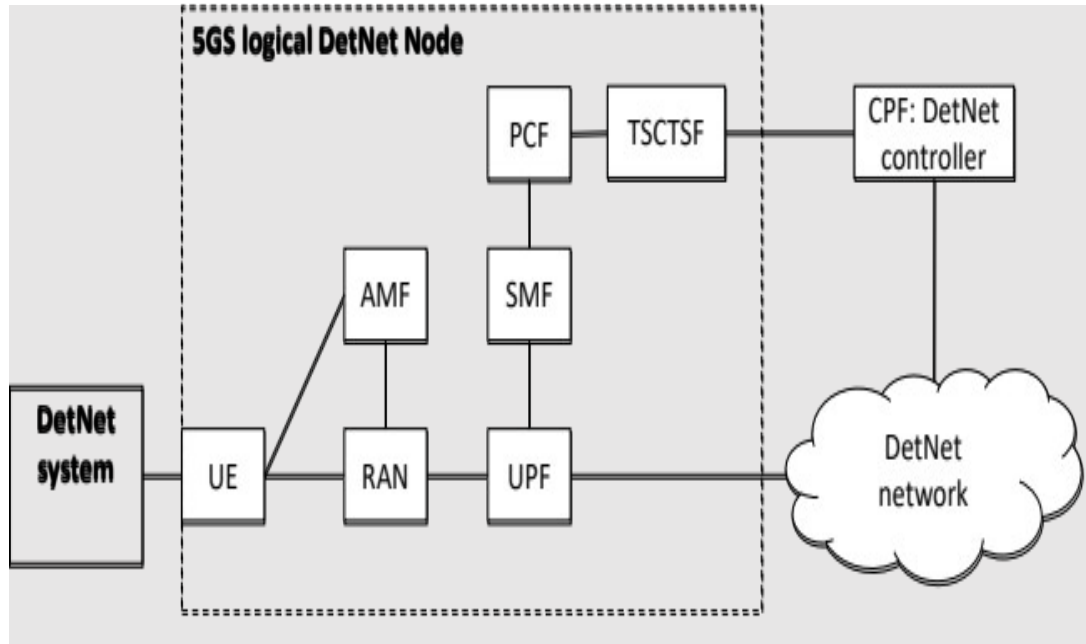

**Applicable attributes as defined in the IETF draft:**

➤ **DetNet node** attributes:

- Max/Min DetNet packet processing delay
- Maximum DetNet packet processing delay variation

➤ **DetNet Link** Attributes:

- Maximum DetNet reservable bandwidth
- Reserved/Available DetNet bandwidth

... and more 5GS logical-node related configurations could be defined further ...

## IETF-116 Conclusion:

- *draft-ietf-detnet-topology-yang* successfully **re-activated**

# 5GS Logical DetNet Node: Enhance DetNet YANG Configuration

## Proposed to define new DetNet parameters:

- DetNet Node Type:
  - For the IP-domain DetNet controller to identify that the 5GS node is a 3GPP defined 5GS, rather than a router with fixed interfaces only
- Composite Node ID <https://datatracker.ietf.org/doc/draft-jlg-detnet-5gs/> :
  - A new parameter to reflect the composite architecture of a 5GS DetNet Node.
- 5GS DetNet Directions – Uplink vs. Downlink:
  - Traffic directions within a 5GS DetNet node which is the association among DS-TT, UP-tunnel and NW-TT

\*<https://datatracker.ietf.org/doc/draft-jlg-detnet-5gs/>

# 5GS Logical DetNet Node: YANG Model Definition

- Principle-1: Reuse the existing IETF Yang model
- Principle-2: 5GS treated as an underlay network and used as a logical node in layer 3 DetNet system
  - RFC 8340 [RFC8340]: topology Yang model allows the configuration of overlay networks on top of the underlay networks

```
augment "/nw:networks/nw:network/nw:node/nw:termination-
point/nw:supporting-termination-point" {
  description
    "5GS Composite Node Type";

  leaf 5gs-composite-node-type {
    type bool;
    description
      "Describe whether the node is 5GS Composite Node ";
  }

  leaf 5gs-direction {
    type bool;
    description
      "Describe whether the node is downstream ";
  }
}
```

## Composite-Node-ID in YANG Model

- Reuse the attribute of “node-id” defined in RFC 8340[RFC8340].

# Next Steps & Future Work

- This version just provided the basic idea of what attributes are requested
  - The formal yang model will be defined in the following version.
- Update I.D. to support more complicated 5GS DetNet scenarios:
  - DetNet YANG for the Binding Relationship:
    - Handle the association among DS-TT, UP-tunnel and NW-TT
  - DetNet YANG for Framed-route:
    - IP packets destined to a range of IPv4 addresses or IPv6 IP prefixes that have been allocated to end devices which can be reached via its DS-TT interfaces.
    - A very useful deployment case in field, e.g., enterprise-based customers could achieve deterministic network services via connected 5GS DS-TT ports.
- Proposal for 3GPP Rel-19
  - DetNet forwarding sub-layer (currently supported) vs. service sub-layer (planning)

Thanks & Comments