



# Mobile Traffic Steering

Room for more standardization... ?

Marco Liebsch

...in discussion with others

IETF#117 – San Francisco, USA

26<sup>th</sup> July 2023

# Topic Background

- Traffic steering in advanced mobile scenarios discussed @ IETF116
- Room for documentation & standardization further elaborated
- Discussion in between IETF116 and IETF117
- Side meeting @IETF117

## Mobile Traffic Steering – Agenda Side Meeting@IETF117

### Outlook

- |   |               |       |
|---|---------------|-------|
| ▪ <u>Introduction &amp; background</u>    | Marco Liebsch | 10min |
| ▪ <u>Use cases and technical analysis</u> | Jeffrey Zhang | 10min |
|   | David Lake    | 10min |
|   | Tianji Jiang  | 10min |
| ▪ <u>Q&amp;A and Discussion</u>           |               | 15min |
| ▪ <u>Lessons Learned and Next Steps</u>   |               | 05min |
| ▪ <u>Closure</u>                          |               |       |

# Technical Background

- DMM was/is about distribution of mobility control- and data plane functions
- End-to-end system comprises..
  - ..Mobility Management System with control plane, Mobility Anchors (MA), radio access, mobile devices, ..
  - ..remaining segments up to Data Network (DN) and Application Servers (AS)
- Today's reality: Distribution and mid-session relocation of a mobile device's MA
- Objective: Session/service continuity after MA relocation

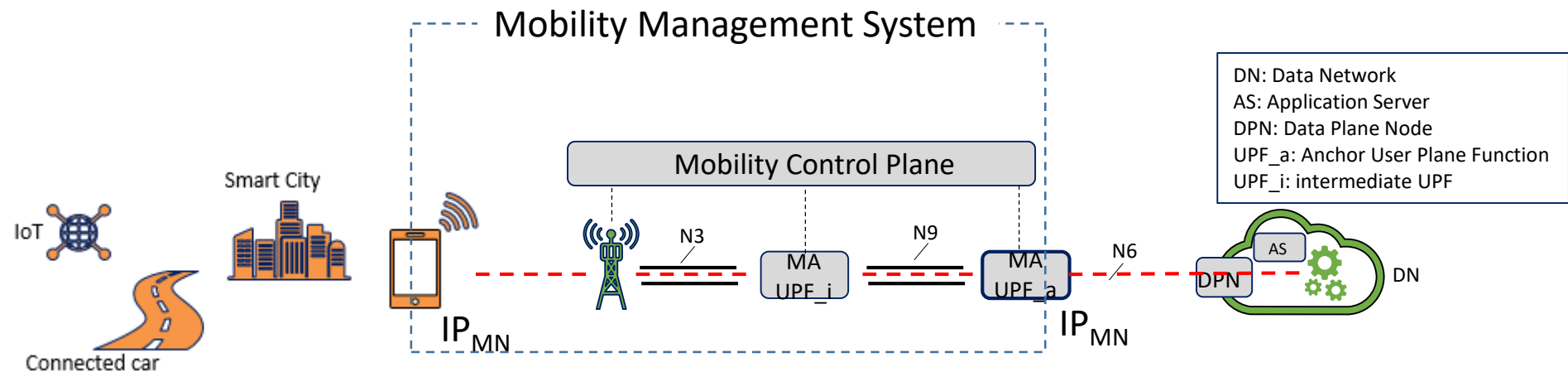

# Target scenario

- IP address continuity by de-coupling of a mobile node's IP address from a topologically matching MA
- Traffic steering of non-routable IP

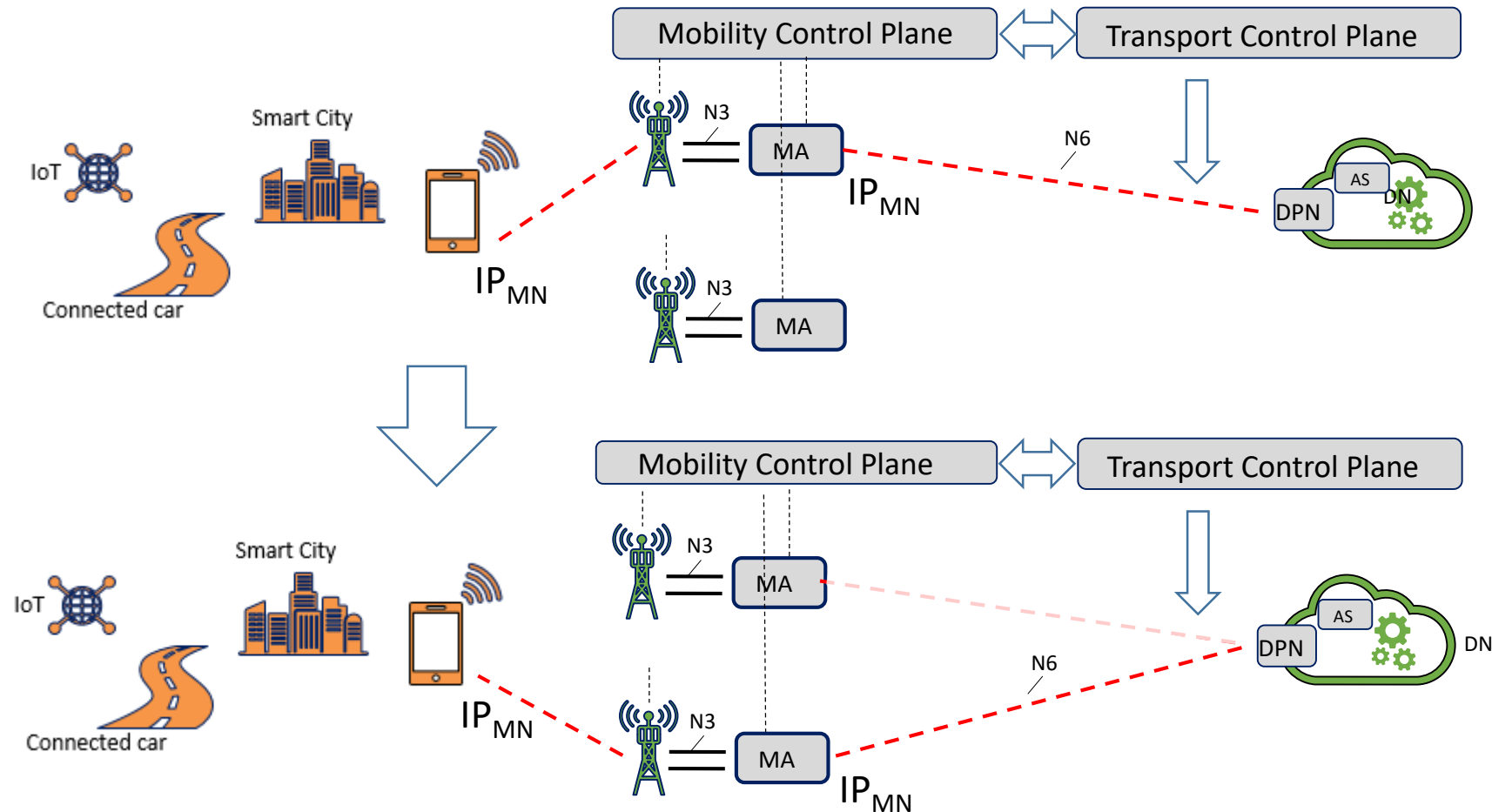

# Discussion

- Interest in such work ?
- Value and relevance of such work ?
- Technical scope of the work ?
  - Semantics and information model to/from Transport Control Plane (1)
  - Transport Control Plane (2) and Control-/Data Plane interface semantics (3)
  - Forwarding Plane (4)
- Intended status and type ?
  - Informational, BCP, ..
  - Analysis, ..

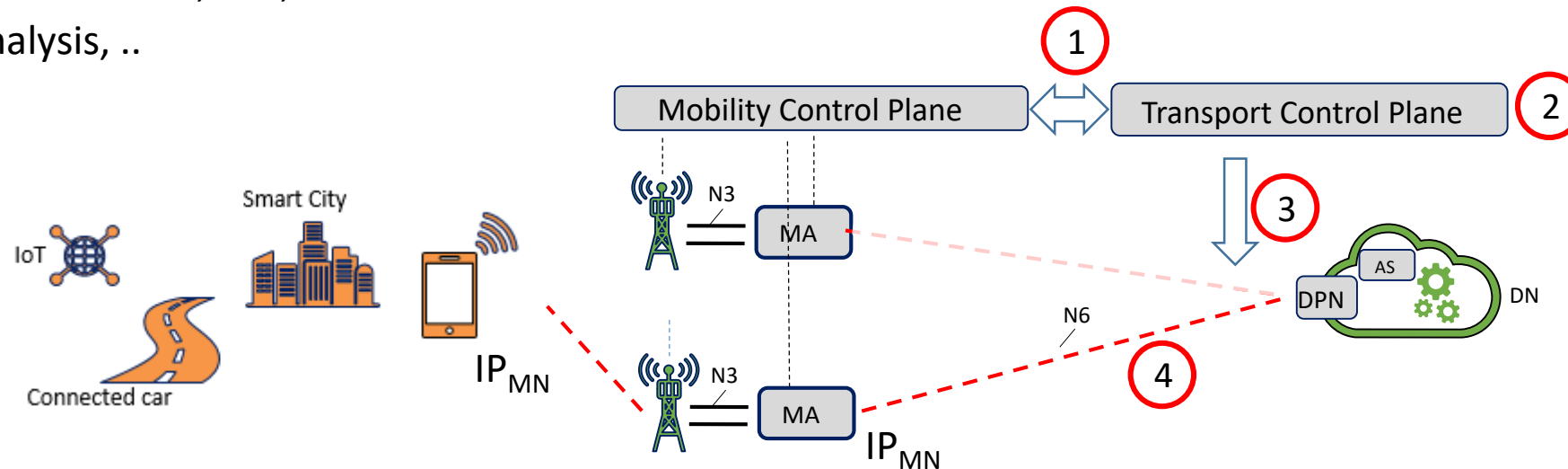

## General topics that came up...

- Beyond UE mobility: Architectures with moving nodes (services, NTN, network functions) on path
- Mid-session node handover: Data plane packet re-ordering during UPF re-location
- UE-to-UE communication
- Cross-domain mobility aspects
- End-to-end QoS
- Functional Architecture representation
- 5GS specifics to complement/leverage (Application Function, UE Route Selection Policy, ..)
- Synergies with other standards groups
- ...

# Side Meeting presentation

Jeffrey Zhang – End Marker in DN for Distributed UPF/ANUP

- Discusses UE-to-UE communication with relocation of one UE's MA/UPF
- Re-ordering may appear during MA/UPF relocation and path switch
- Solves re-ordering issues at N6 reference point in between MAs/UPFs and Hub PE/Data Network
- Applies EndMarker principles; Hub PE issues EndMarker

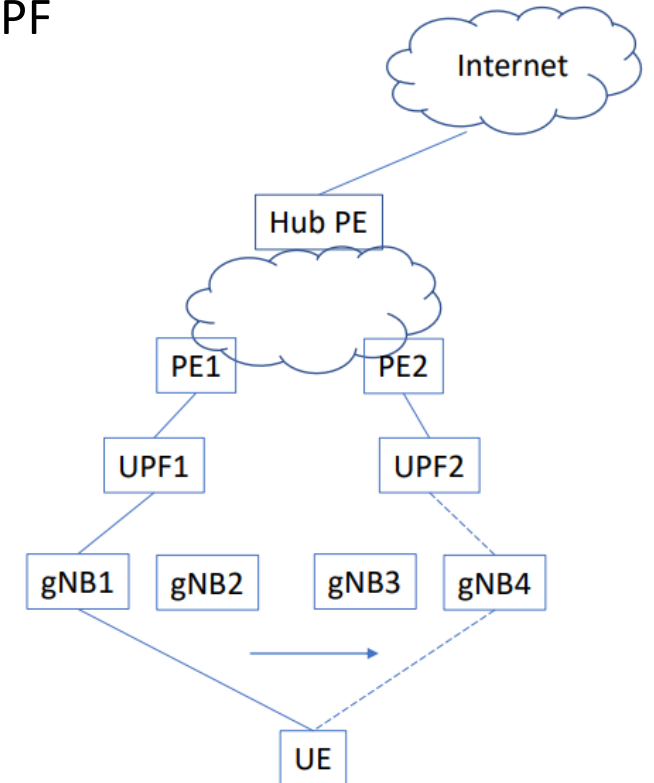

# Side Meeting presentation

## Tianji Jiang – Mobile Traffic Steering in 3GPP SA2 & IETF CATS

- Discusses shortcomings in applying end-to-end traffic steering principles to 5G System
- Discusses the use of 3GPP architecture's AF to support traffic steering
- Traffic steering in the IETF CATS WG
- 3GPP R19 XRM and demand for end-to-end low latency and QoS
- Edge Computing

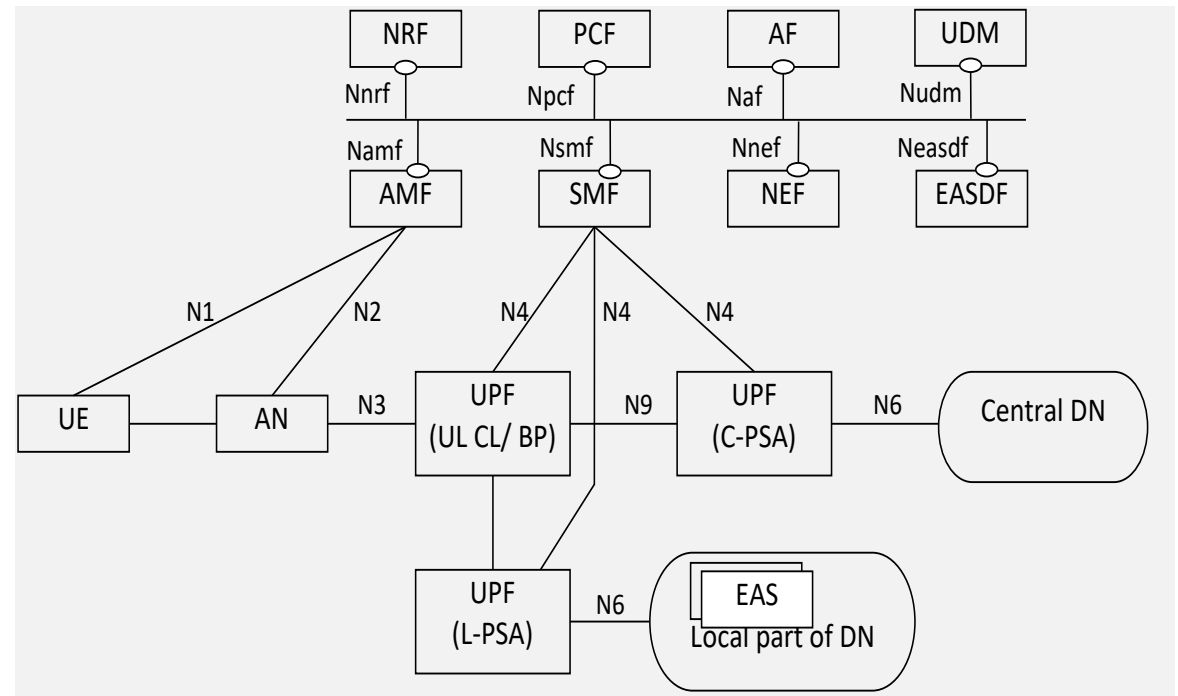

# Potential work in a controller-based architecture

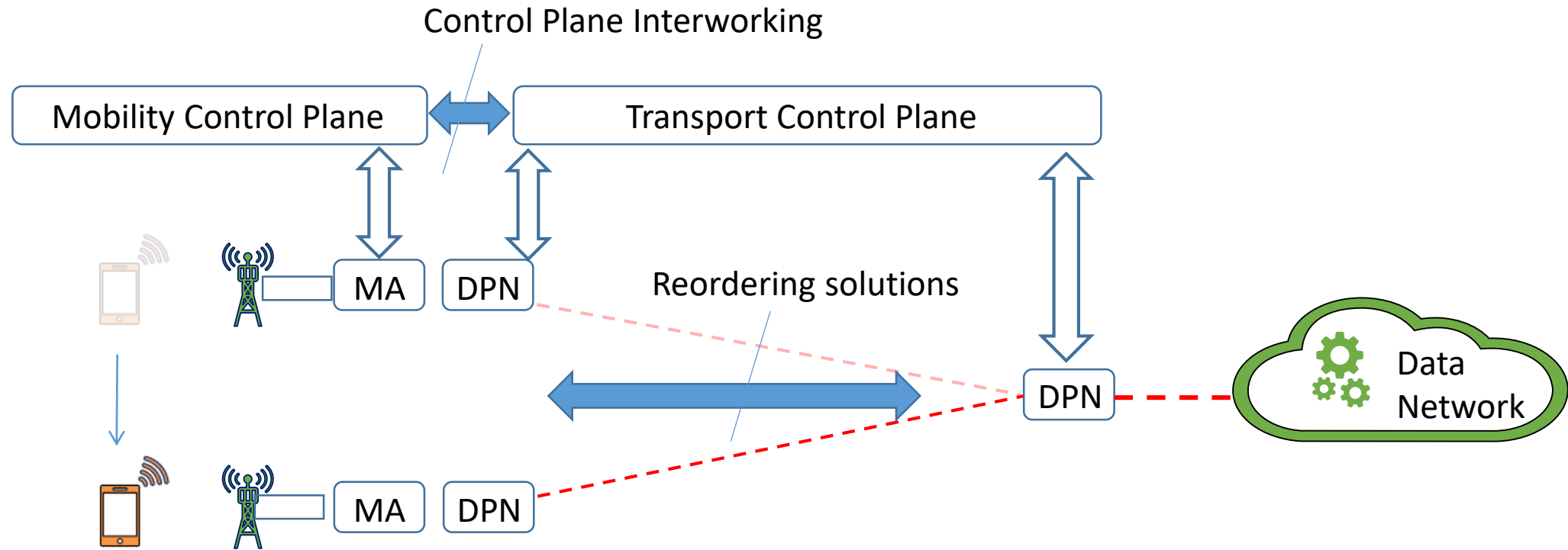

# Potential work in an architecture with distributed routing plane

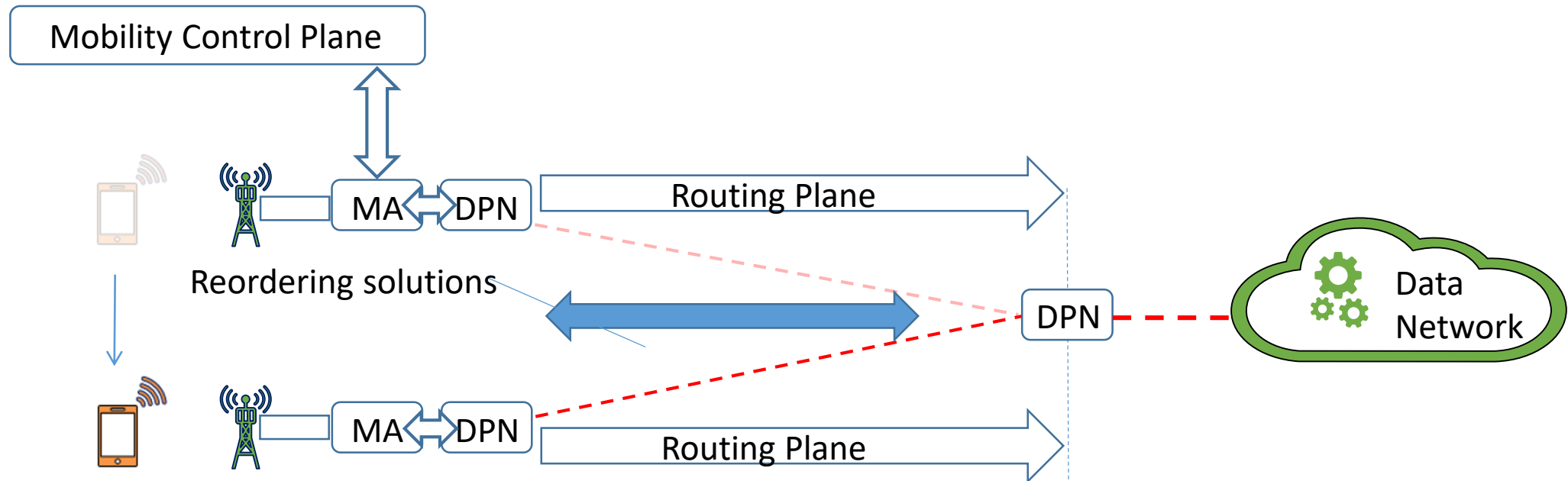

# Lessons Learned & Next

## Main conclusion

- End-to-end problem statement cannot be generalized and depends on deployment details
- Potential work identified; standardization vs. carrier-specific solutions

## Potential work

- Semantics in between transport network controller and mobility control plane
- Data Plane optimizations during path switching (re-ordering)

## Starting point...?

- Documentation of deployment options
- Document discusses possible solution- and standardization options