

Mobility Capability Negotiation (MCN)

(draft-yan-dmm-man-**11**)

Zhiwei Yan, **Tianji Jiang**, Jianfeng Guan, Tao Huang, Jong-Hyouk Lee
@IETF 117 (San Francisco, CA)

What has been done up to IETF-116 (Yokohama)

- draft-yan-dmm-man-10

The I.D. ver#10 was the 10th iteration based on previous comments, feedback, discussions, etc. with IETF experts.....

- MCN for IPv6 Categorization:
 - OPMIPv6/PMIPv6 suite protocols
 - OMIPv6/MIPv6 suite protocols
- MCN w/ 5G Mobility Pattern
- MCN w/ Prioritized Considerations

Previous Work (Up-to IETF-116*): MCN for IPv6 Categorization

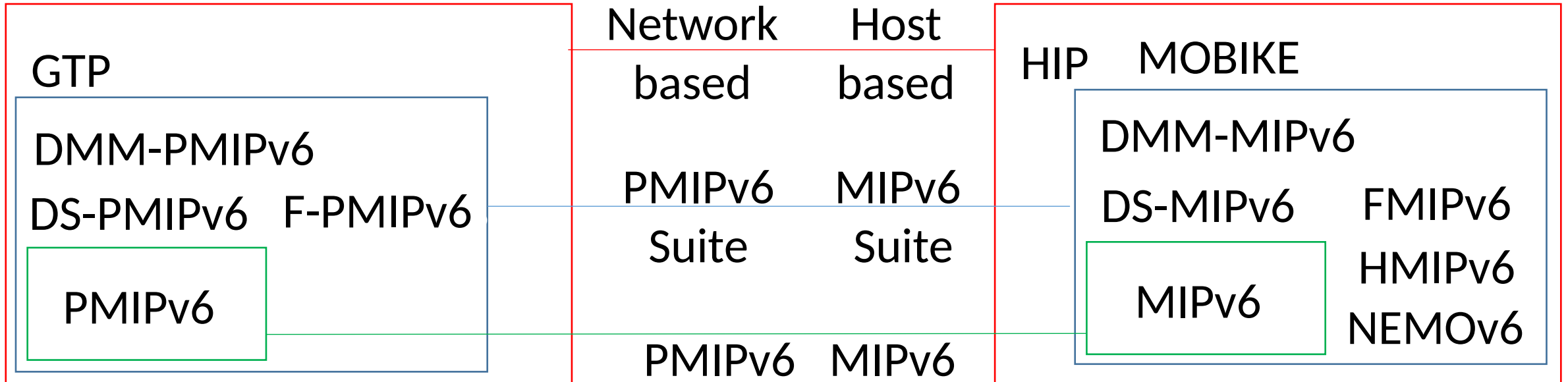

- **PMIPv6**: the network-based mobility management protocol specified by RFC5213
- **PMIPv6 Suite Protocols**: extensions based on PMIPv6
- Network-based mobility management protocols: L3 mobility management protocols which have no functional requirements on the mobile node

- **MIPv6**: the host-based mobility management protocol specified by RFC6275
- **MIPv6 Suite Protocols**: extensions based on MIPv6
- Host-based mobility management protocols: L3 mobility management protocols which have functional requirements on the mobile node

* draft-yan-dmm-man-

Previous Work (Up-to IETF-116*): MCN w/ 5G Mobility Pattern

5G Mobility Pattern (TS 23.501)

The Mobility Pattern is a concept used by the AMF (Access and Mobility Management Function) to **characterise and optimise the UE mobility** with the aid of NWDAF (Network Data Analytics Function)

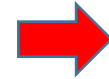

Intelligent mobility support

General mobility support

NWDAF (TS 23.288)

Subscription of UE

Statistics of UE mobility

Network local policy

UE assisted information



Statistics predictions



Historical attachment

Moving trajectory

Mobility capacity □

Previous Work (Up-to IETF-116*): MCN w/ Prioritized Considerations

- Priority 1: Follow network ability
- Priority 2: Follow host preference
- Priority 3: Support the functional extensions
- Priority 4: Support the performance enhancements
- *In default: network based scheme if it can be supported*

- If the host prefers host-based protocols, a negotiation is executed to handover from network-based protocol to host-based protocol.
- After initial attachment, a profile will be generated in the management store to record the selected or preferred protocol of this host.
- When the handover happens, the network will check the selected or preferred protocol. But the network also needs to notify the host if the selected protocol cannot be supported herein.

Discussion Points: IETF-116 => 117* (San Francisco)

(I.D. changes: *draft-yan-dmm-man-10* => *11*)

I.D. contents updated:

- Significantly restructured the I.D. based on previous feedback / comments / discussion/work
- Proposed a dichotomy of mobility management & capability negotiation protocols (MCN)
- MCN in Mobile IPv6 Domain
- MCN in 3GPP 5GS
 - ❖ 5GS general scenarios
 - ❖ 5GS Roaming scenarios

| | |
|---|----|
| 1. Introduction | 3 |
| 1.1. Terminologies | 3 |
| 1.2. Protocol Categories for Management and Negotiation | 3 |
| 1.3. General Procedure of Negotiation | 5 |
| 2. Mobility capability negotiation on IPv6 domain | 6 |
| 3. The general 3GPP 5GS-based mobility capability negotiation | 8 |
| 3.1. 5GS Wireless-specific Mobility Capability Negotiation | 8 |
| 3.2. 5GS UE IP-address Negotiation & Management | 10 |
| 4. Mobility capability negotiation for 5GS-based roaming | 11 |
| 4.1. Mobility Capability Negotiation in Home-Routed (HR) Roaming | 11 |
| 4.2. Mobility Capability Negotiation in Local Break Out (LBO) Roaming | 13 |
| 5. Security Considerations | 14 |
| 6. IANA Considerations | 14 |
| 7. References | 14 |
| 7.1. Normative References | 14 |
| 7.2. Informative References | 16 |

* *draft-yan-dmm-man-11*

Mobility Capabilities: Wireline vs. Wireless

- Wireline (Mobile-IP) devices:
 - Mainly on IP-related address allocation, provisioning, traffic switching and redirection, optimization, etc.
- Wireless (5GS) devices:
 - Mobile IP-related capabilities, *and*
 - Wireless-specific categories: radio, mobile management core network (MM CN), session management core network (SM CN), etc.

Then, based on the analysis of various Mobile-IP and 5GS scenarios, we summarize the protocols for capability management & negotiation into ...

A Dichotomy of MCN protocols

- Host-initiated protocols:
 - Defining the mobility management protocols that require the involvement of mobile end devices in order to accomplish the mobility management.
- Network-based protocols:
 - Indicating the mobility management protocols that require the non-involvement of mobile end devices in order to accomplish the mobility management.

MCN in Mobile IPv6 Domain

- **MIPv6**: the host-based mobility management protocol specified by RFC6275
- **MIPv6 Suite Protocols**: extensions based on MIPv6
- **PMIPv6**: the network-based mobility management protocol specified by RFC5213
- **PMIPv6 Suite Protocols**: extensions based on PMIPv6
- Host-initiated protocols:
 - **MIPv6** and **MIPv6 suit protocols**, along with some other solutions, e.g., the Host Identity Protocol (HIP) [RFC7401] and the IKEv2 Mobility and Multihoming Protocol (MOBIKE) [RFC4555]
- Network-based protocols:
 - **PMIPv6** and **PMIPv6 suit protocols**, along with some other solutions, e.g., the GPRS Tunneling Protocol (GTP).

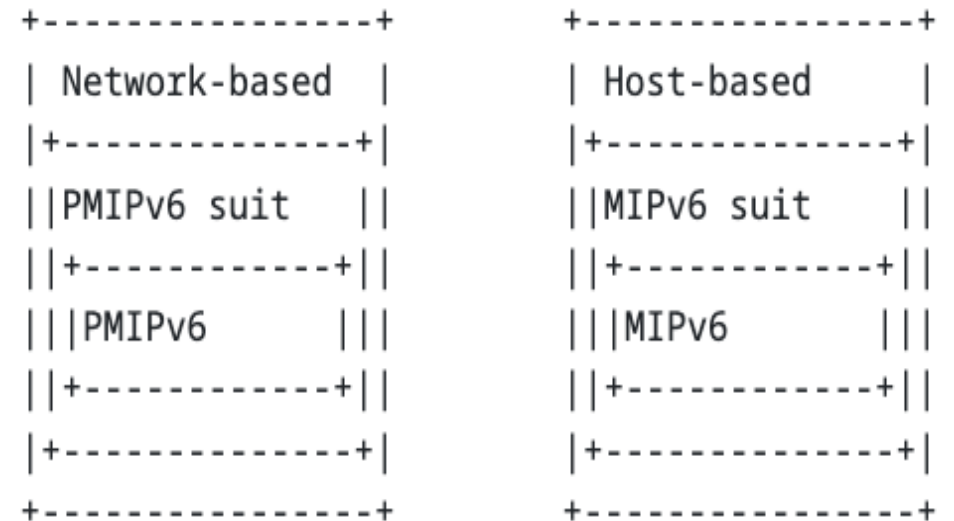

MCN in 3GPP 5GS General Scenario

- **5GS Wireless-specific MCN**

- Capabilities comprised of UE radio, 5GMM CN, and 5GSM CN
- Integration of host-initiated and network-based modes:
 - UE initiates the process by providing its capabilities to the network (i.e., the 5GS) and the network (via 5G NFs) negotiates based on the system settings

- **5GS UE IP-address Negotiation & Management**

- Very flexible 5G UE IP address management
- Network-based 'dynamic mode':
 - to be allocated by the SMF (of a PDU session)
 - to be allocated via DHCPv4/DHCPv6 with the SMF itself being the DHCP server;
 - to be allocated via DHCPv4/DHCPv6 with external DHCP servers
- Host-initiated 'static mode':
 - based on a UE's subscription record that is stored either in the UDM/UDR or in the DHCP/DN-AAA server of the 5GS or external domain.

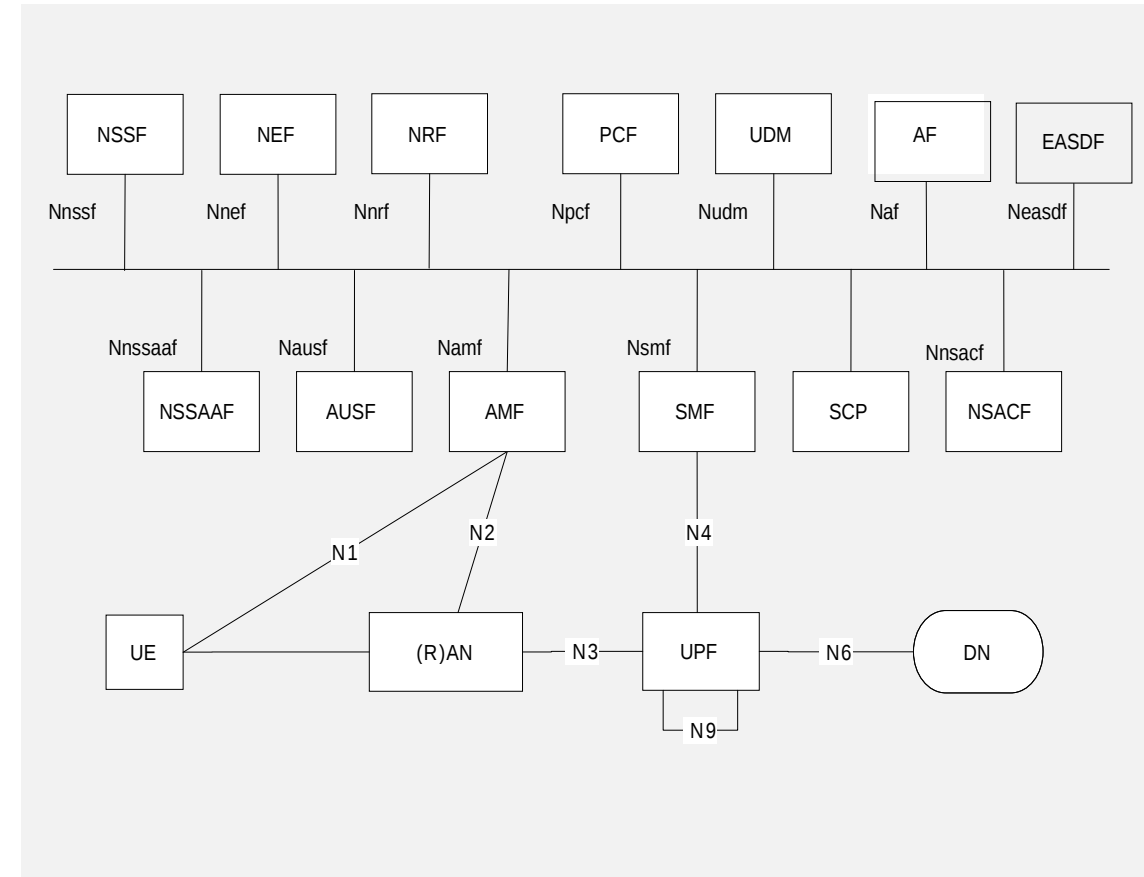

MCN in 3GPP 5GS Based Roaming

- **MCN in 5GS Roaming: Home-Routed (HR)**

- Network-based' mode: UE in visited network (VPLMN); connect back to home 5GC (HPLMN) for address and parameters negotiation.
- Host-initiated' mode: UE in visited network (VPLMN); UE's subscriber record retrieved from the HPLMN UDM/UDR
- H-UPF like HA (Home Agent*) in mobile-IP domain

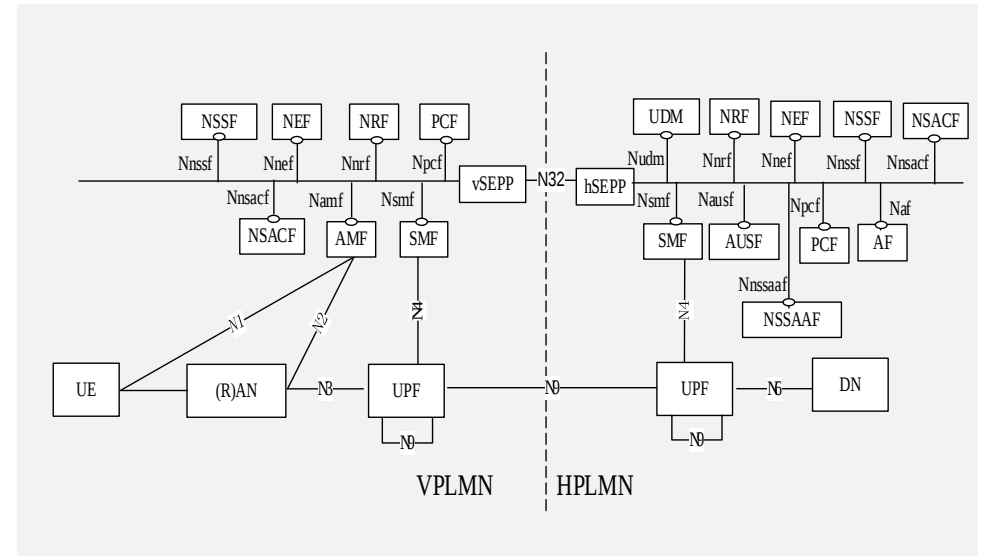

- **MCN in 5GS Roaming: Local BreakOut (LBO)**

- No host-initiated scheme for IP capability negotiation : no retrieval of the host-based IP address settings from HPLMN; only network-based scheme provided by VPLMN
- V-UPF like MAG[±] (Mobile Access Gateway) in mobile-IP domain

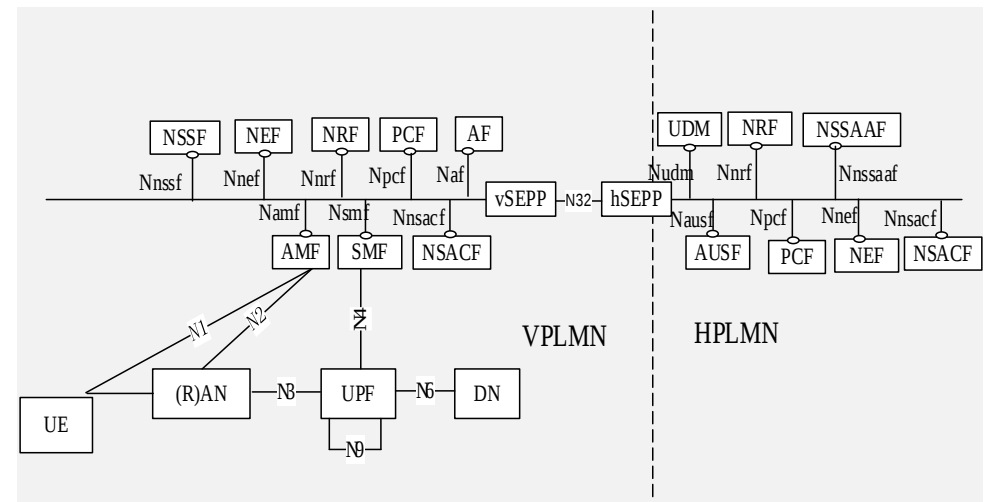

Summary & Next Steps

- I.D. Significantly restructured based on previous feedback/comments/discussions/work
- Proposed a dichotomy of mobility management & capability negotiation protocols (MCN)
- MCN in Mobile IPv6 Domain
- MCN in 3GPP 5GS
 - ❖ 5GS general scenarios
 - ❖ 5GS Roaming scenarios

... other DMM WG-adopted documents revolving around the mobile user plane, which bears the natural extensibility between the wireless and the wireline (IP) domains, e.g. N3, N9, N6...

... and this MCN draft focusing on the mobile management plane, and we have done significant work to analyze the mobility capability management & negotiation in both the mobile IPv6 and the 5GS...

So ...

WG Adoption?