

Considerations for Protection of SR Networks

draft-liu-rtgwg-sr-protection-considerations-01

Presenter: Yisong Liu (China Mobile)

Weiqiang Cheng (China Mobile)

Changwang Lin (New H3C Technologies)

Xuesong Geng (Huawei Technologies)

Yao Liu (ZTE Corp.)

IETF 117

Protection of SR networks

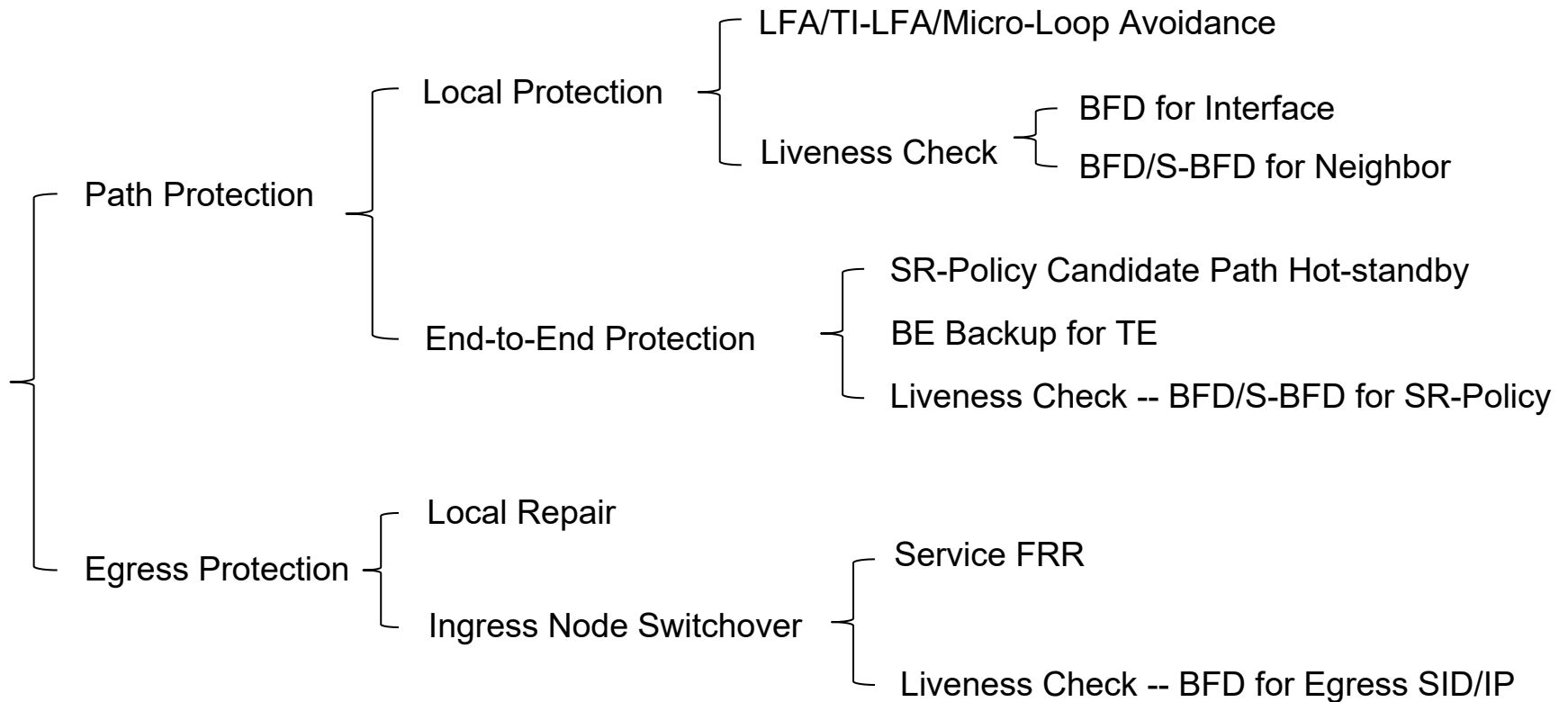

Changes of the draft

- Update to 01 version after IETF-116
- Rewrite Section 4 (Implementation Recommendations)
 - Deployment for single-homed scenario & multi-homed scenario
 - Recommendations for BFD
- Add Section 5 (Considerations for SRv6 Segment List Compression)
 - Discuss the impact of SRv6 Segment-List compression on protection
 - TI-LFA with C-SID & micro-Loop avoidance with C-SID

Protection Deployment for Single-homed Scenario

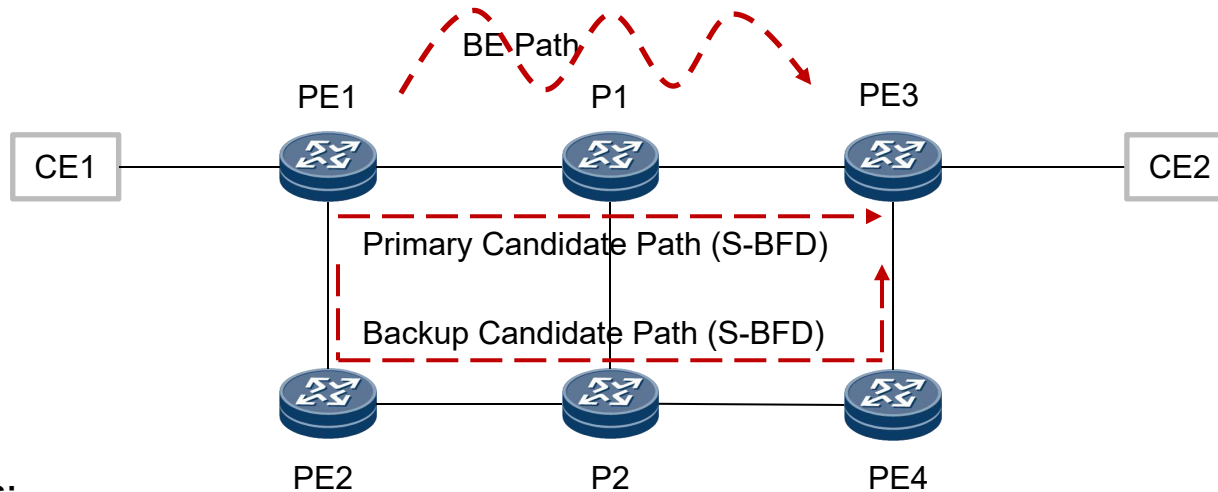

Deployments:

- TI-LFA as local protection
- Multiple candidate paths switchover as end-to-end protection
- BE backup for TE

Protection of SR-BE traffics:

- TI-LFA, triggered by BFD for links and neighbors

Protection of SR-TE traffics:

- High SLA cases (end-to-end protection preferred):
 - Only candidate path switchover
- Fast traffic restoring cases (local protection preferred):
 - First, TI-LFA, triggered by BFD for links and neighbors
 - Then, Candidate path switchover, triggered by BFD/S-BFD for SR Policy
- BE backup for TE
 - Operate when multi-point faults (When link PE1-P1 & P2-PE4 both fail, SR BE path can still reach PE3)
 - Exceptions (dropping preferred): strong SLA requirements

Protection Deployment for Multi-homed Scenario

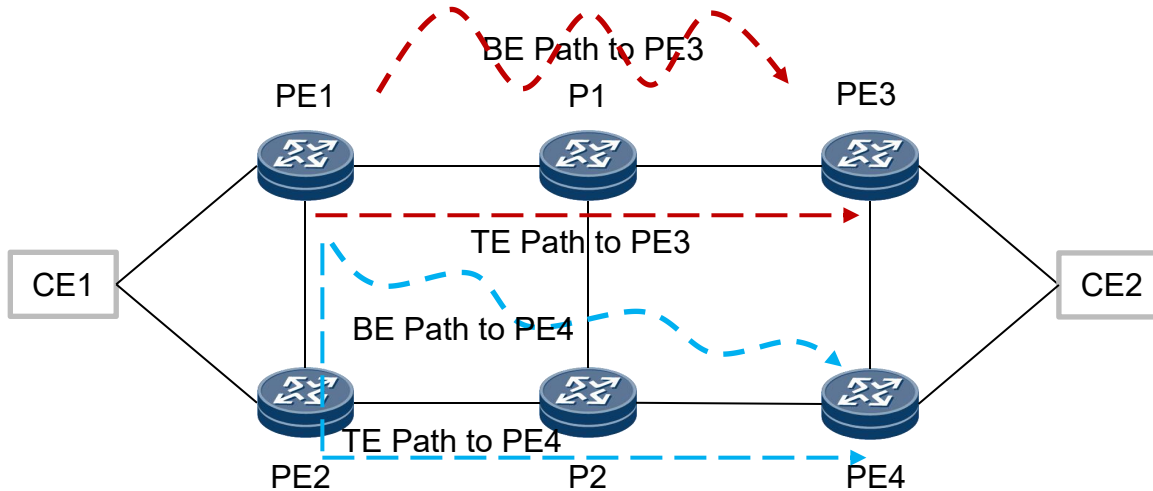

Deployments:

- For each egress PE, same with Single-homed Scenario
 - TI-LFA as local protection
 - Multiple candidate paths switchover as end-to-end protection
 - BE backup for TE
- Ingress Node Switchover
 - Monitor the liveness of egress nodes: BFD for egress nodes, or validating IGP routes of egress nodes
 - Switchover among different egress nodes (for example, when PE3 fails, PE1 switch from SR-Policy-to-PE3 to SR-Policy-to-PE4)

Recommended BFD Time Interval

Trigger of TI-LFA:

Local protection $\leq 50\text{ms}$

- BFD for links and neighbors: $10\text{ms} * 3$

Trigger of candidate paths switchover (primary candidate path down):

- BFD for primary candidate path of SR Policy: $50\text{ms} * 3$

Trigger of BE backup for TE (all candidate paths down):

- BFD for backup candidate path of SR Policy: $100\text{ms} * 3$

Trigger of egress protection:

End-to-end protection $\leq 300\text{ms}$

- BFD for egress nodes: $50\text{ms} * 3$

TI-LFA with C-SID

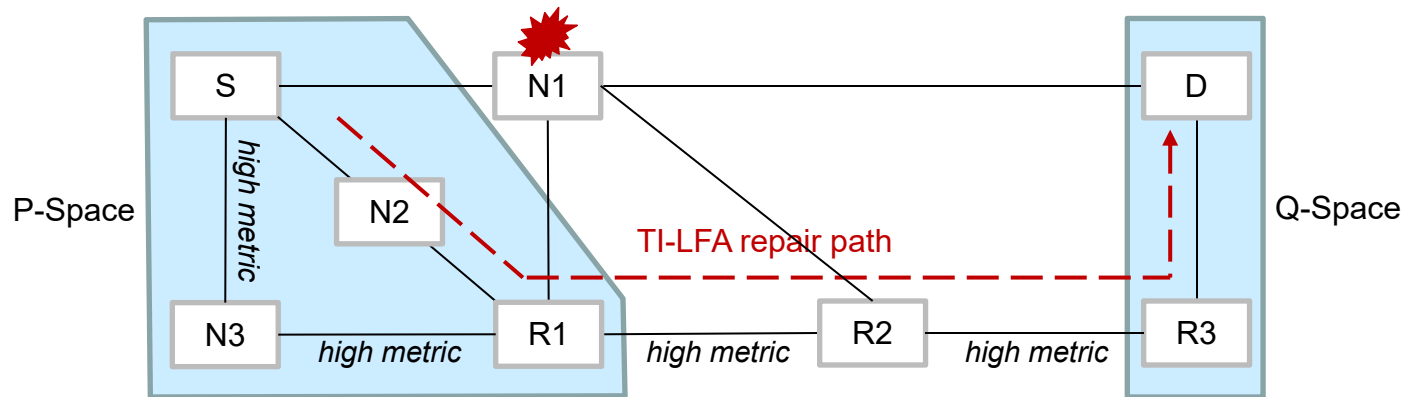

When SRv6 Segment List compression is enabled, the repair node will check the compression capabilities of nodes along the repair path and try to use C-SIDs to encode the repair path.

NEXT-C-SID:

| Repair List | |
|-------------|-------------|
| R1-R2-End.X | R2-R3-End.X |
| Next-C-SID | Next-C-SID |

REPLACE-C-SID:

| Repair List | |
|---------------|---------------|
| R1-R2-End.X | R2-R3-End.X |
| Replace-C-SID | Replace-C-SID |

Micro-Loop Avoidance with C-SID

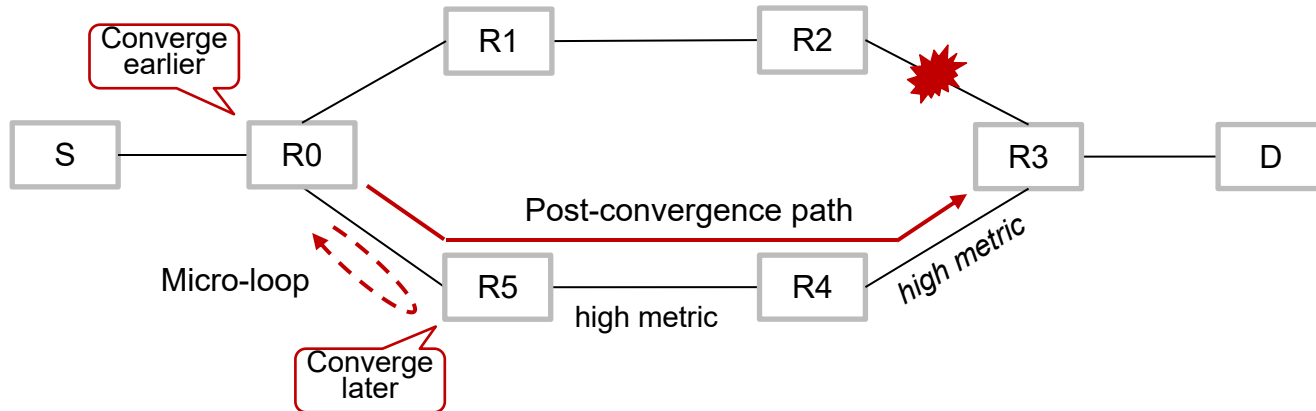

When SRv6 Segment List compression is enabled, the converging node will check the compression capabilities of nodes along the post-convergence path and try to use C-SIDs to encode the path.

NEXT-C-SID:

| | |
|---------------------------------|-------------|
| Loop-free Post-convergence Path | |
| R5-R4-End.X | R4-R3-End.X |
| Next-C-SID | Next-C-SID |

REPLACE-C-SID:

| | |
|---------------------------------|---------------|
| Loop-free Post-convergence Path | |
| R5-R4-End.X | R2-R3-End.X |
| Replace-C-SID | Replace-C-SID |

Running Code

Lab Interop-test Status

Multiple vendors have passed SRv6 protection interoperability tests hosted by China Mobile in 2021 and 2022:

- China Unitechs Unified Controller
- Huawei NE40E and NE5000E
- H3C CR16010H-FA and CR19000-8
- ZTE M6000-8S Plus and M6000-3S
- Ruijie RG-N8010-R

Both single AS and Inter AS scenarios have passed interoperability testing.

Deployment Status

Trials of SRv6 protection in five branch networks of China Mobile in 2021 and 2022

- Beijing
- Zhejiang
- Fujian
- Guangdong
- Henan

Next Step

- Any questions or comments?
- Ask for adoption call