

Layer 2 topology discovery

Solving the Topology-Related configuration in L2 fronthaul network

The Radio Fronthaul Network

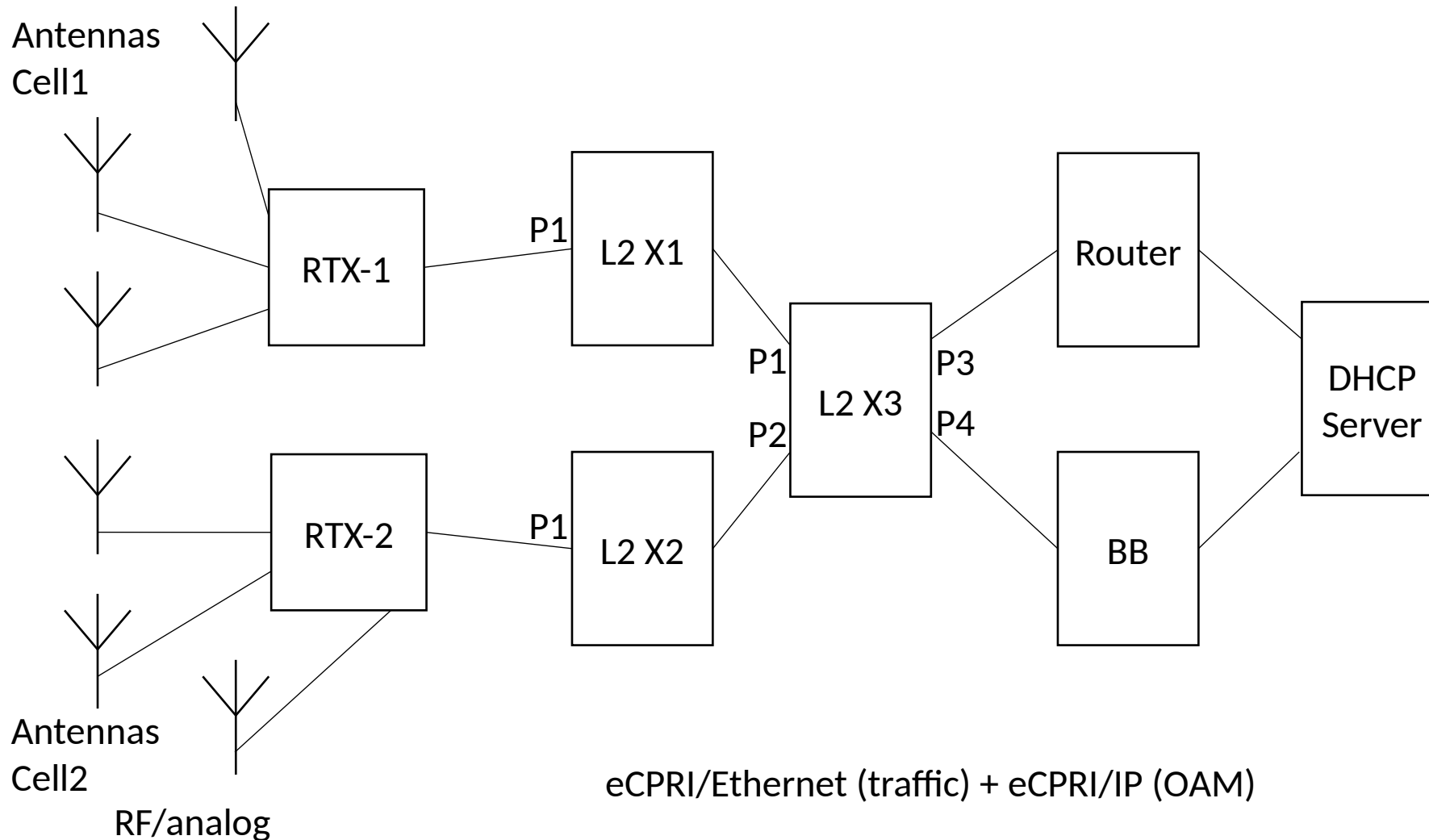

In order to properly configure the RTX, BB needs to know the MAC address and what Antennas are connected as each antenna is related to a cell and sector.

On IPv6 the L2 topology is known by the server because of LDRA.

On IPv4 this is not possible as LDRA doesn't exist and DHCP4 doesn't allow multiple RAIO.

Limits of DHCPv4 and goal

- Specifically, in DHCPv4 lacks the following capabilities:
 - There is no support for hierarchy of Relay Agents.
 - It is not clear if there is an attribute that could carry interface or port related information, like DHCPv6's Interface-ID [RFC3315] [RFC6221].
 - There is no specification for how to employ Relay Agents in a Layer 2 device.
- Objective of the draft is
 - Introduce the hierarchy of Relay Agents
 - Specify how a Relay Agents in a Layer 2 device has to be implemented.