

Optimizing Traffic Distribution in Multicast Snooping LANs

Joseph Huang
David Vandewalle
Nate Karstens

Garmin

IETF 121 mboned Working Group

First Problem

- Coexistence of devices with varying link speeds

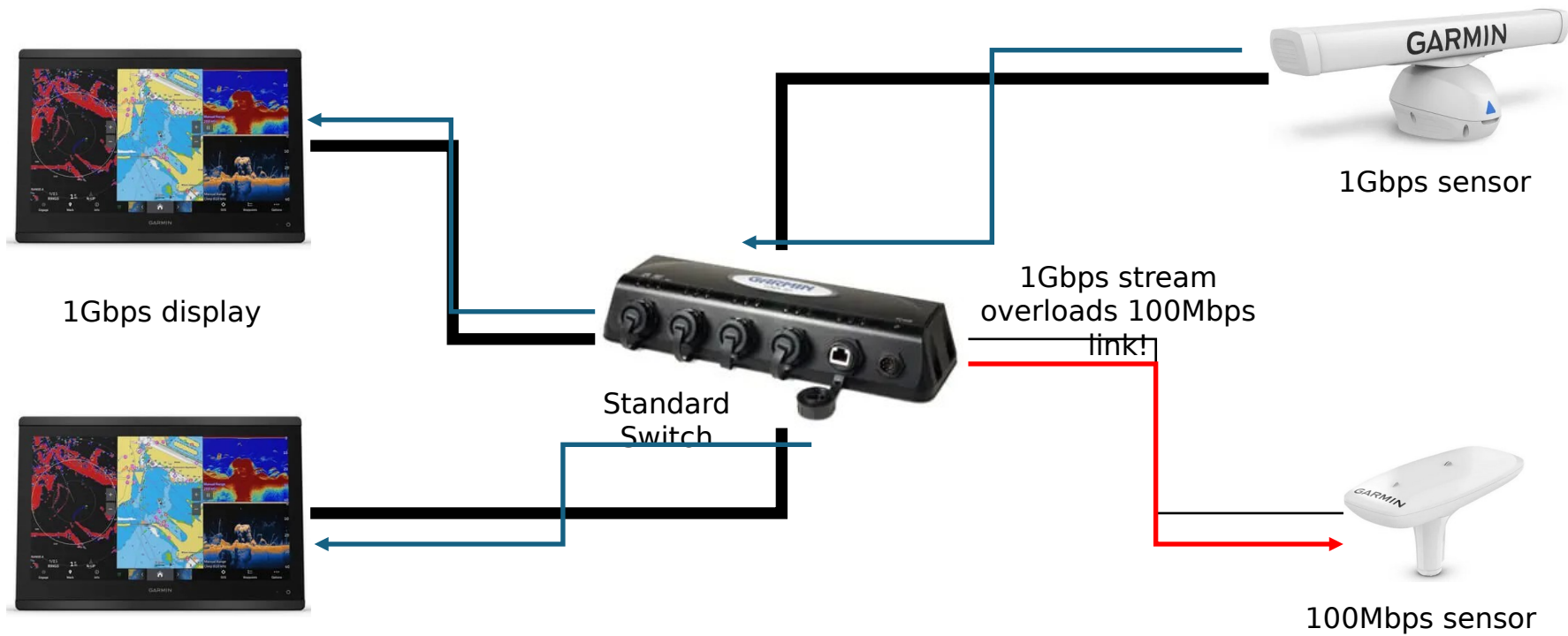

The Solution

- Each data stream assigned a different multicast address
- Devices only request streams they are interested in or can handle
- Multicast snooping forwards packets only to interested ports (default block mode)

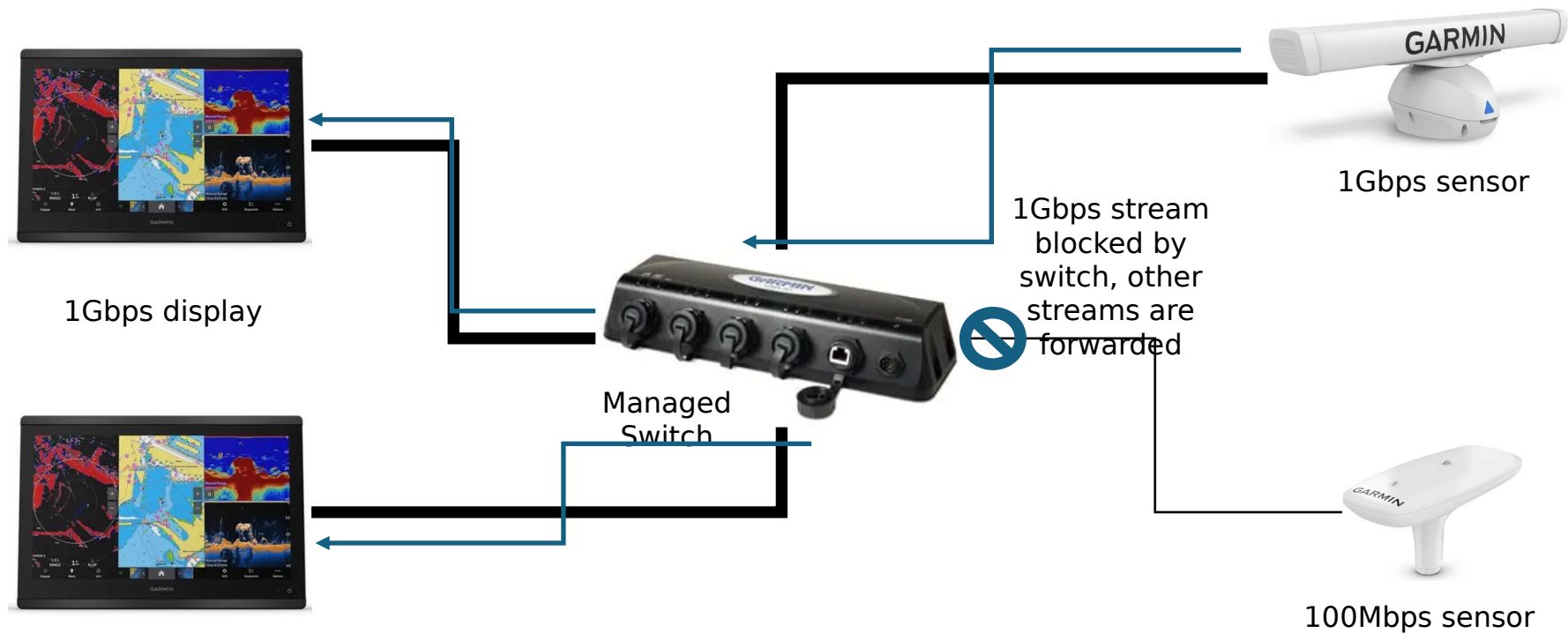

IGMP/MLD

- Used by hosts to report multicast group membership to neighboring multicast routers
- Messages
 - Query (General and Group-Specific)
 - Used by multicast routers to solicit updates for multicast group membership
 - “There is normally only one Querier per physical network”
 - There is an algorithm to negotiate the Querier
 - Intercepted by multicast snooping switches and used to mark mrouter port
 - Report
 - Indicates group membership
 - IGMPv2/MLDv1 report suppression
 - Intercepted by multicast snooping switches and used to update port membership bit-field in ATU table

The Problem – RFC 4541 Forwarding Rules

- §2.1.1 (Control Path) – A snooping switch should forward IGMP Membership Reports **only to those ports where multicast routers are attached.**
- §2.1.2 (Data Path) – Packets with a destination IP address outside 224.0.0.X which are not IGMP should be forwarded according to group-based port membership tables and **must also be forwarded on router ports.**

Problem Network

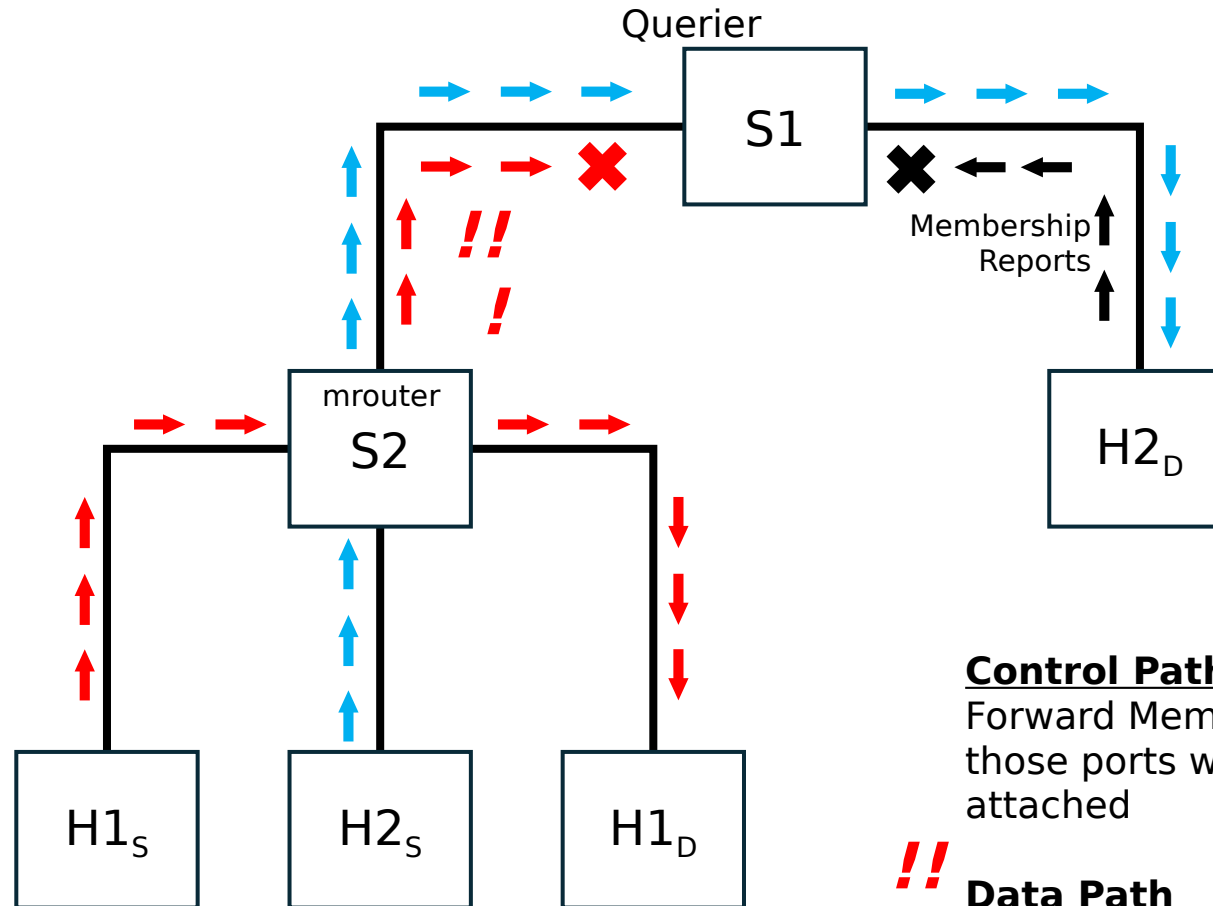

Control Path

Forward Membership Reports only to those ports where multicast routers are attached



Data Path

Packets must also be forwarded on router ports

Fix #1

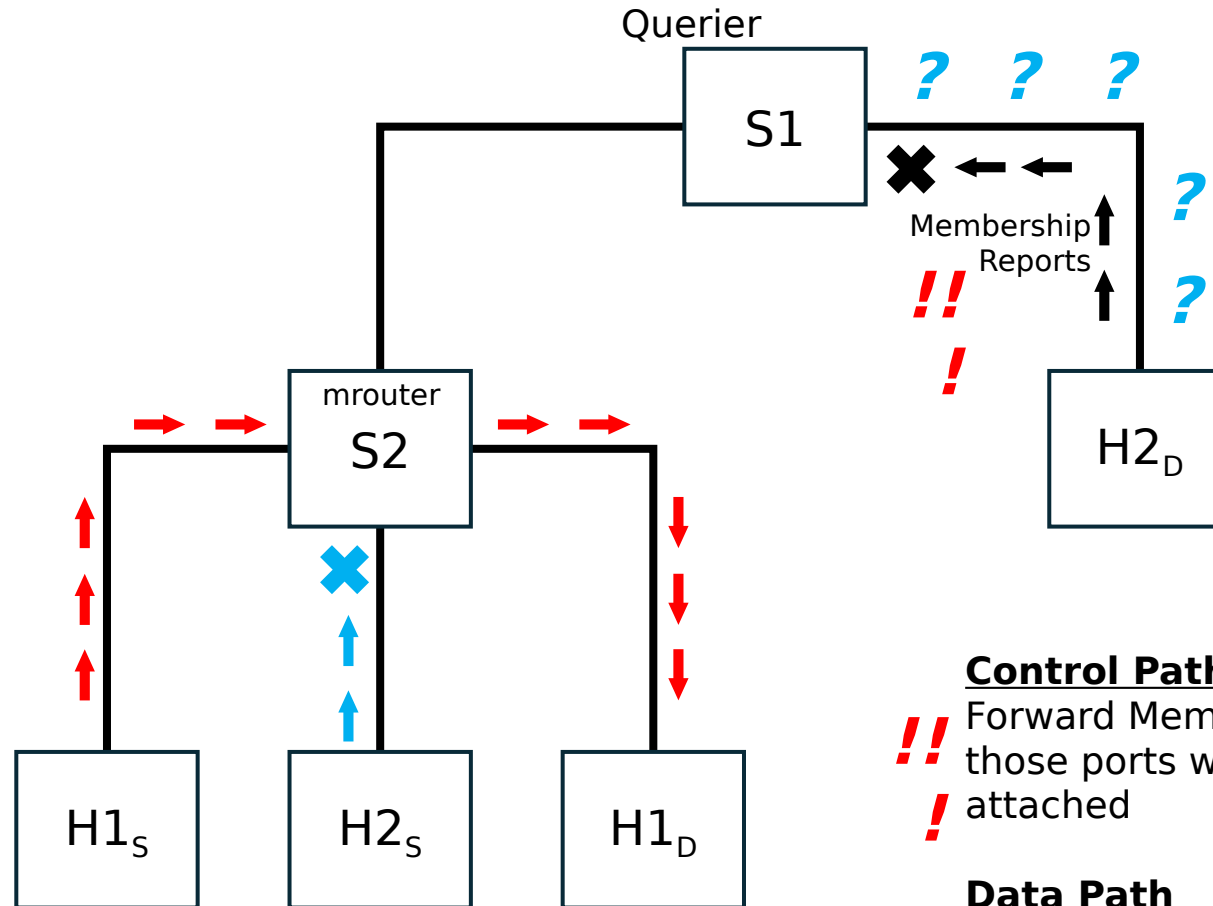

Control Path

!! Forward Membership Reports only to those ports where multicast routers are attached
!

Data Path

Packets must also be forwarded on router ports

Fix #2

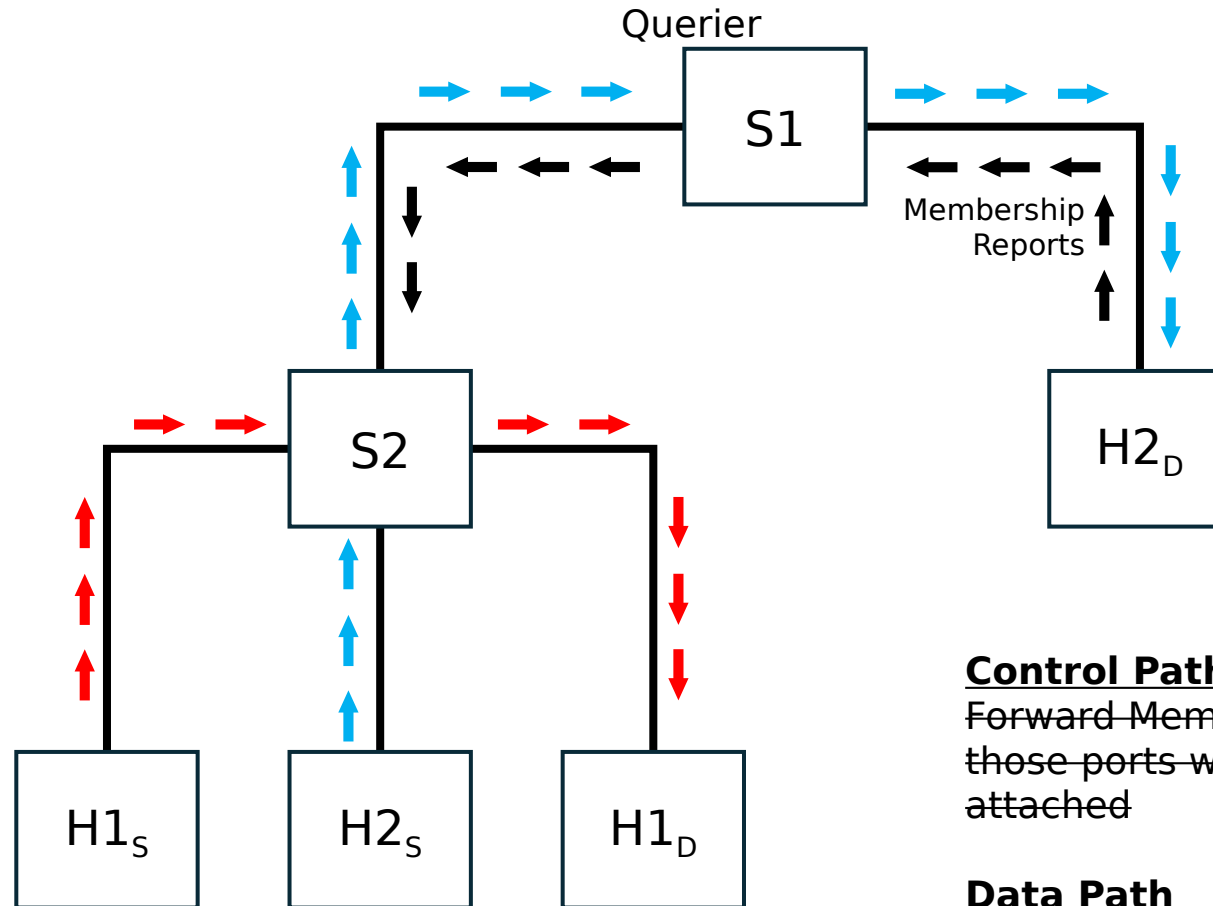

Control Path

Forward Membership Reports only to those ports where multicast routers are attached

Data Path

Packets must also be forwarded on router ports

Come to pim!