

An Autonomic Control Loop with AI-planning and NLP for achieving self-reconfiguration in an sliced network

Angela María Rodríguez Vivas^{1,2}

Oscar Mauricio Caicedo¹

Jéferson Campos Nobre³

NMRG 78th meeting

IETF 121, Dublin + Online

November 7th, 2024

¹University of Cauca, Colombia

²Comfacauca University Corporation, Colombia

³Federal University of Rio Grande do Sul, Brazil



Universidad
del Cauca



AGENDA

- Problem
- Proposal
- Evaluation
- Conclusions

PROBLEM

Configuring and Reconfiguring Network Slices

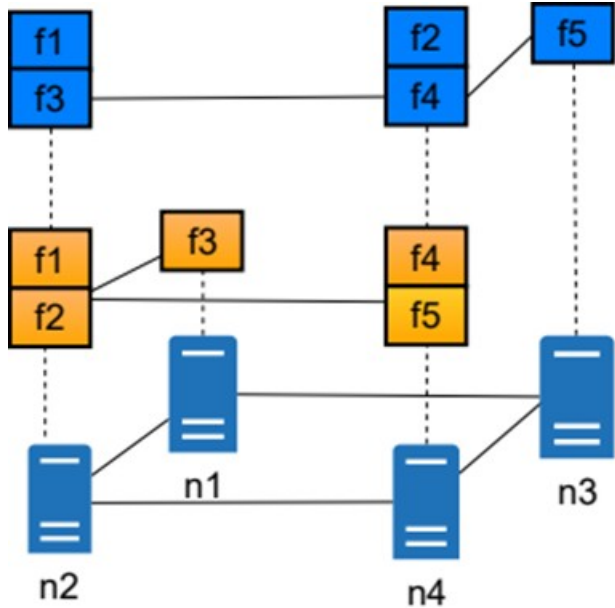

Configuring a network slice:

→ map its VNFs and virtual links onto the substrate network (SN).

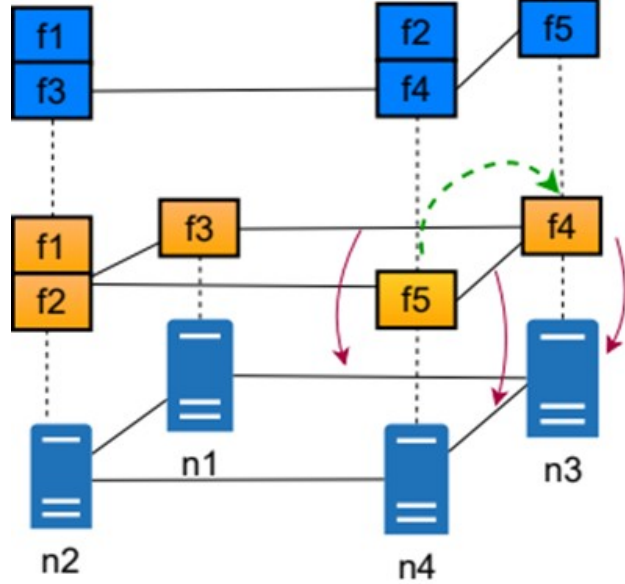

Reconfiguring a network slice:

→ migrate its VNFs and virtual links from current to destination host nodes and physical links.

→ turn the network from an initial undesired-configuration into a goal-desired-configuration.

PROBLEM

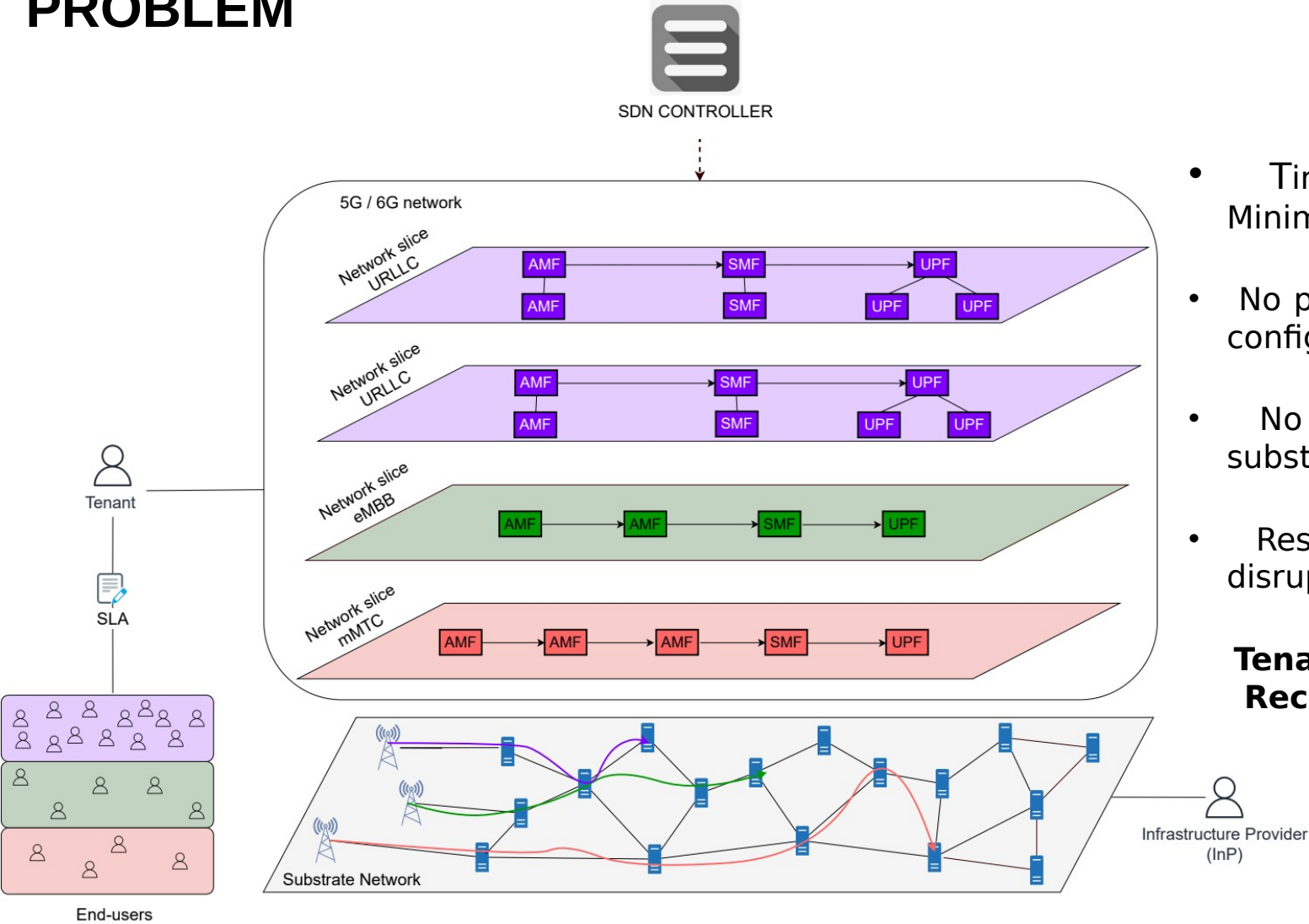

- Timely reconfigurations → Minimal dependence on InP
- No prior knowledge on network configurations commands
- No in-depth knowledge on substrate network
- Respect SLAs → Avoid service disruption

Tenant-side Network Slice Reconfiguration Problem (TsNSRP)

PROBLEM

Given an *undesired* network configuration, how to compute reconfiguration actions (VNF migrations) on-the-fly to turn SDN into a *desired* configuration?

PROBLEM

Hypothesis

- An Autonomic Control Loop (ACL) shaped with Automated Planning (AP) and NLP could compute reconfiguration plans (sets of ordered VNF-migration actions) on-the-fly to turn the network from an *undesired* into a *desired* configuration.
- How to include the AP technique as decision maker in the ACL?
- How ACL decisions can be guided by high-level network management policies?

PROPOSAL Architecture

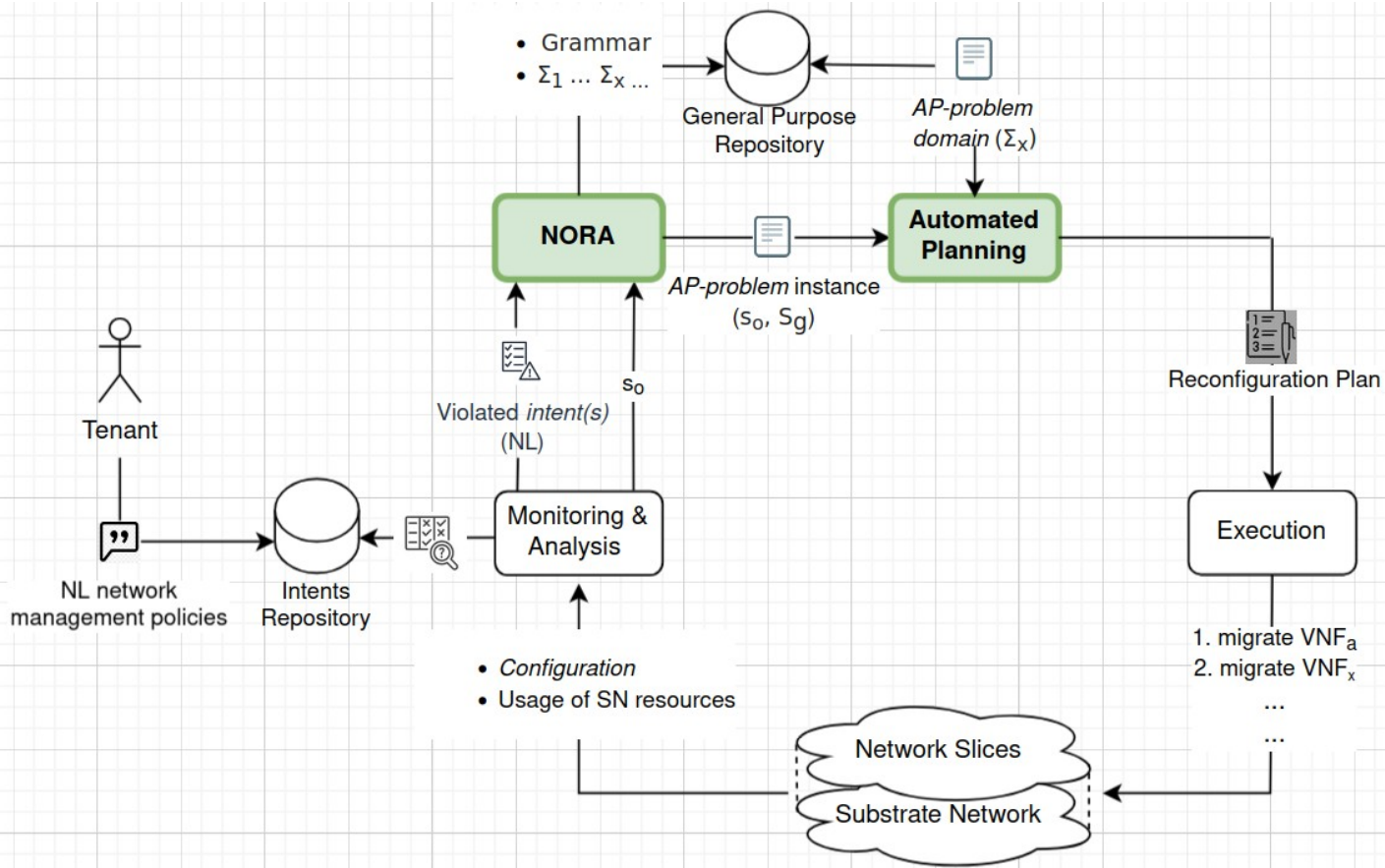

- Monitoring & Analysis observes the managed network.
- NORA transforms high-level network management policies into an AP notation.
- AP decides which of the possible VNF migrations (from Σ_x) will take place.
- Execution enforces the reconfiguration plan
- The managed network is turned from an *undesired* configuration (s_o) into a *desired* configuration (S_g)

PROPOSAL

Automated Planning Model

- AP explores how to use autonomous techniques (e.g., heuristics) to solve complex planning and scheduling problems [Ghallab, Nau and Traverso, 2016].

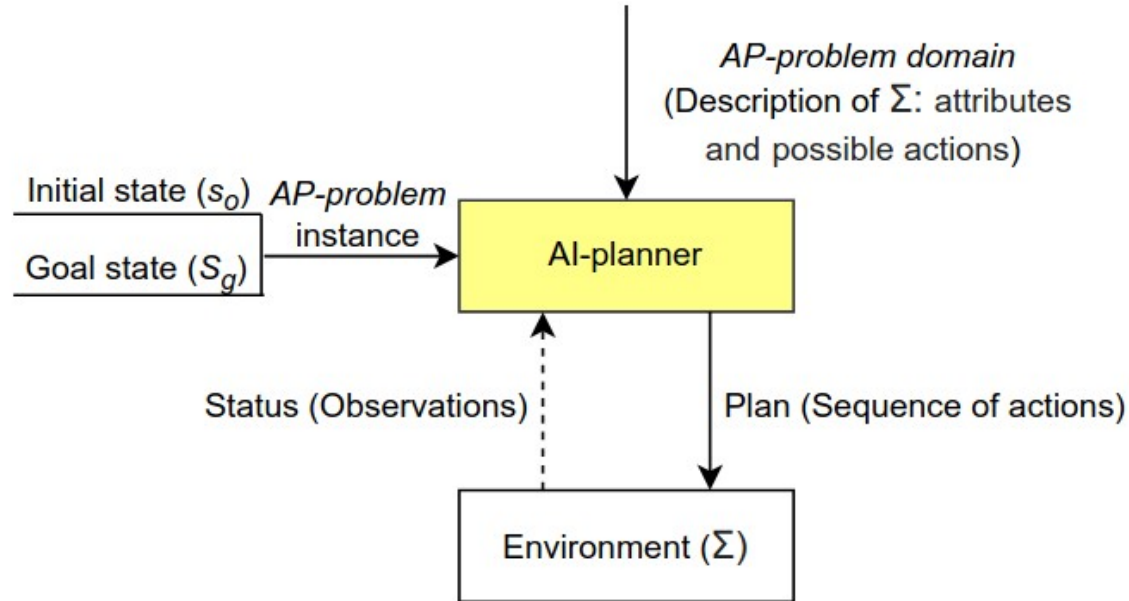

State-Transition System $\Sigma = (S, A, \gamma)$

$S = \{s_1, s_2, s_3, \dots\}$ finite set of states

$A = \{a_1, a_2, \dots\}$ finite set of actions

$\gamma : S \times A \rightarrow 2^S$ State Transition Function

AP-problem: (Σ, s_0, S_g) , $s_0 \in S$ and $S_g \subseteq S$

→ States Graph!

Plan: $[a_0, a_1, \dots, a_p]$, $a_x \in A$

$[s_0, s_1, \dots, s_p]$, $s_p \in S_g$

→ Path in the states graph from s_0 to s_p

PROPOSAL

System Model

Symbol	Description
SUBSTRATE NETWORK	
$SN = \{N, P\}$	Set of computing nodes and physical links on the SN.
n_i	i -th node on SN , $n_i \in N$.
(n_i, n_j)	Physical link whose path communicates n_i and n_j , $(n_i, n_j) \in P$
m	Size of N , <i>i.e.</i> , number of computing nodes in SN .
z	Size of P , <i>i.e.</i> , number of physical links in SN .
CPU_{n_i}	Processing capacity of n_i .
$BW_{(n_i, n_j)}$	Bandwidth capacity of (n_i, n_j) .

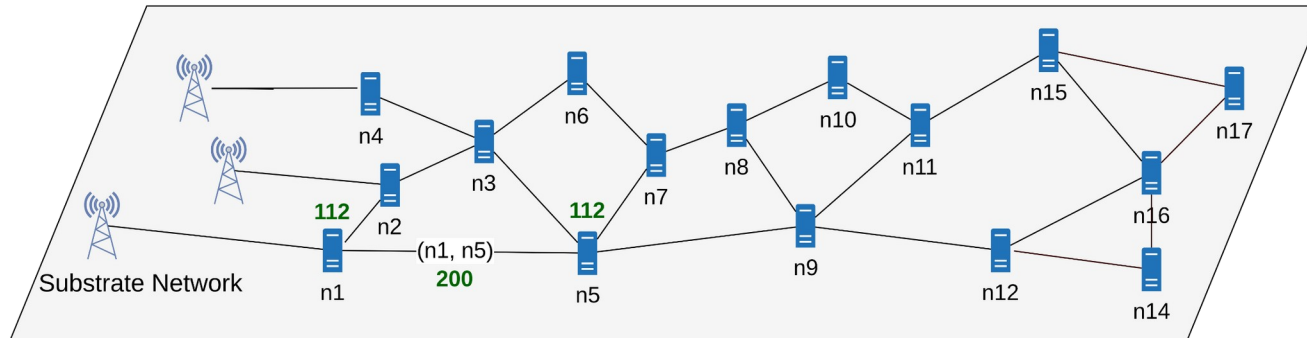

PROPOSAL

System Model

Symbol	Description
VIRTUALIZED/SLICED NETWORK	
$G = \{F, V\}$	Set of VNFs and virtual links across the virtualized network G .
C_j	j -th network slice composing G .
k	Number of network slices in G .
$f_i^{C_j}$	i -th VNF of C_j , $f_i^{C_j} \in F$
$(f_{i-1}, f_i)^{C_j}$	Virtual link chaining $f_{i-1}^{C_j}$ and $f_i^{C_j}$, $(f_{i-1}, f_i)^{C_j} \in V$
h_{C_j}	Number of VNFs contained in C_j .
$(h-1)_{C_j}$	Number of virtual links contained in C_j .
q	Size of F , <i>i.e.</i> , number of VNFs in G
r	Size of V , <i>i.e.</i> , number of virtual links in G
$\Delta CPU_{f_i^{C_j}}$	Processing demand of $f_i^{C_j}$.
$\Delta BW_{(f_{i-1}, f_i)^{C_j}}$	Bandwidth demand of $(f_{i-1}, f_i)^{C_j}$
$\epsilon(f_i^{C_j})$	Scaling factor of $f_i^{C_j}$.

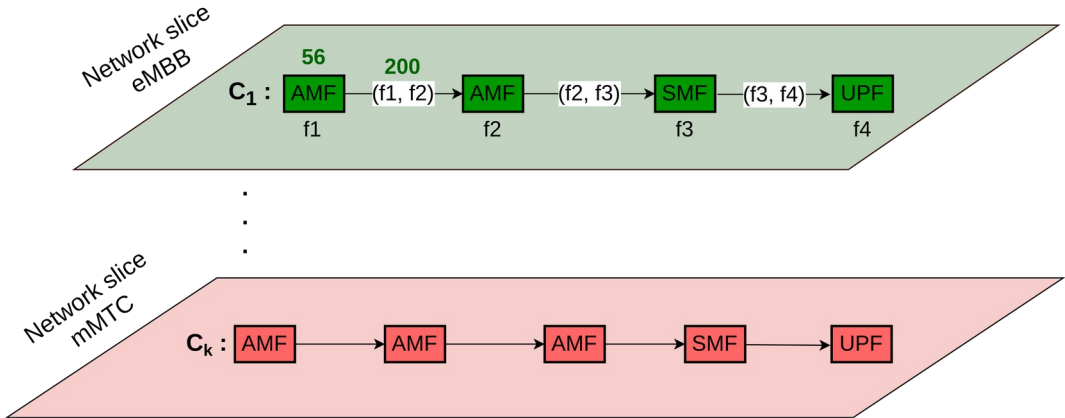

PROPOSAL

System Model

Symbol	Description
<i>CONFIGURATION AT TIME STEP t</i>	
$M(t)$	Configuration of the 5G network slicing (at time step t).
$M_{C_j}(t)$	Configuration of C_j
$f_i^{C_j} \rightarrow n_i$	Mapping of $f_i^{C_j}$ onto n_i
$(f_{i-1}, f_i)^{C_j} \rightarrow (n_i, n_j)$	Mapping of $(f_{i-1}, f_i)^{C_j}$ onto (n_i, n_j)
$EP_{n_i}(t)$	Residual processing capacity of n_i .
$EP_{(n_i, n_j)}(t)$	Residual bandwidth capacity of (n_i, n_j) .
T	Number of all possible VNF migrations.

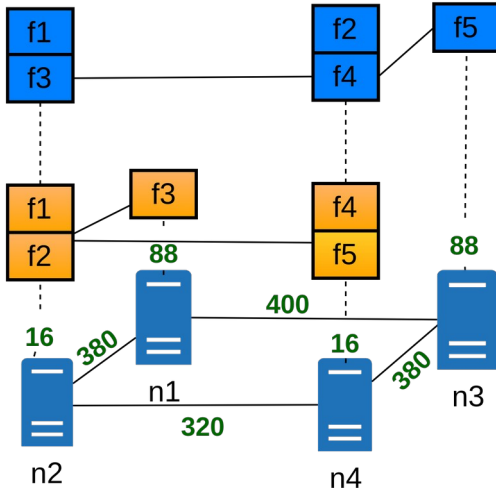

$$M_{C_j}(t) : \begin{cases} M_{f_i^{C_j}}(t) : f_i^{C_j} \rightarrow n_x, \dots, f_h^{C_j} \rightarrow n_z \\ M_{(f_{i-1}, f_i)^{C_j}}(t) : (f_{i-1}, f_i)^{C_j} \rightarrow (n_x, n_y), \dots, (f_{h-1}, f_h)^{C_j} \rightarrow (n_w, n_z) \end{cases}$$

$$EP_{n_i}(t) = CPU_{n_i} - \sum_{b=1}^{h_{C_a}} \sum_{a=1}^k \Delta CPU_{f_b^{C_a}} \times \epsilon(f_b^{C_a}),$$

$$\Leftrightarrow M_{f_b^{C_a}}(t) : f_b^{C_a} \rightarrow n_i, EP_{n_i}(t) \geq 0$$

$$EP_{(n_i, n_j)}(t) = BW_{(n_i, n_j)} - \sum_{b=1}^{h_{C_a}} \sum_{a=1}^k \Delta BW_{(f_{b-1}, f_b)^{C_a}},$$

$$\Leftrightarrow M_{(f_{b-1}, f_b)^{C_a}}(t) : (f_{b-1}, f_b)^{C_a} \rightarrow (n_i, n_j), EP_{(n_i, n_j)}(t) \geq 0$$

PROPOSAL

AP-Problem Domain in PDDL

Planning Domain Definition Language

$$\frac{EP_{n_d}(t)}{\Delta CPU_{f_i^{C_j}} \times \epsilon(f_i^{C_j})} \geq 1$$

$$\frac{EP_{(n_x, n_d)}(t)}{\Delta BW_{(f_{i-1}, f_i)^{C_j}}} \geq 1$$

$$\frac{EP_{(n_d, n_y)}(t)}{\Delta BW_{(f_i, f_{i+1})^{C_j}}} \geq 1$$

(:action migrate-vnf

:parameters(
)

```
?vnf-to-migrate - vnf
?from-node ?to-node - host-node
; PREVIOUS VNF ON SFC
?prev-vnf - vnf
?prev-vnf-node - host-node
?v-link1-to-migrate - virtual-link
?from-p-link1 ?to-p-link1 - physical-link
; NEXT VNF ON SFC
?next-vnf - vnf
?next-vnf-node - host-node
?v-link2-to-migrate - virtual-link
?from-p-link2 ?to-p-link2 - physical-link
```

```
:precondition(and
; VNF TO MIGRATE
(vnf-mapped-to ?vnf-to-migrate ?from-node)
(not(= ?from-node ?to-node))
(>= (/ (embedding-cpu ?to-node)
(* (scaling-factor) (required-cpu
?vnf-to-migrate)))) 1)
; PREVIOUS LINK TO MIGRATE
(v-link-mapped-to ?v-link1-to-migrate
?from-p-link1)
(not(= ?from-p-link1 ?to-p-link1))
(next-vnf ?prev-vnf ?vnf-to-migrate)
(vnf-mapped-to ?prev-vnf ?prev-vnf-node)
(adjacent-nodes-i-j ?to-p-link1 ?prev-vnf-node
?to-node)
```

PROPOSAL

AP-Problem instance in PDDL

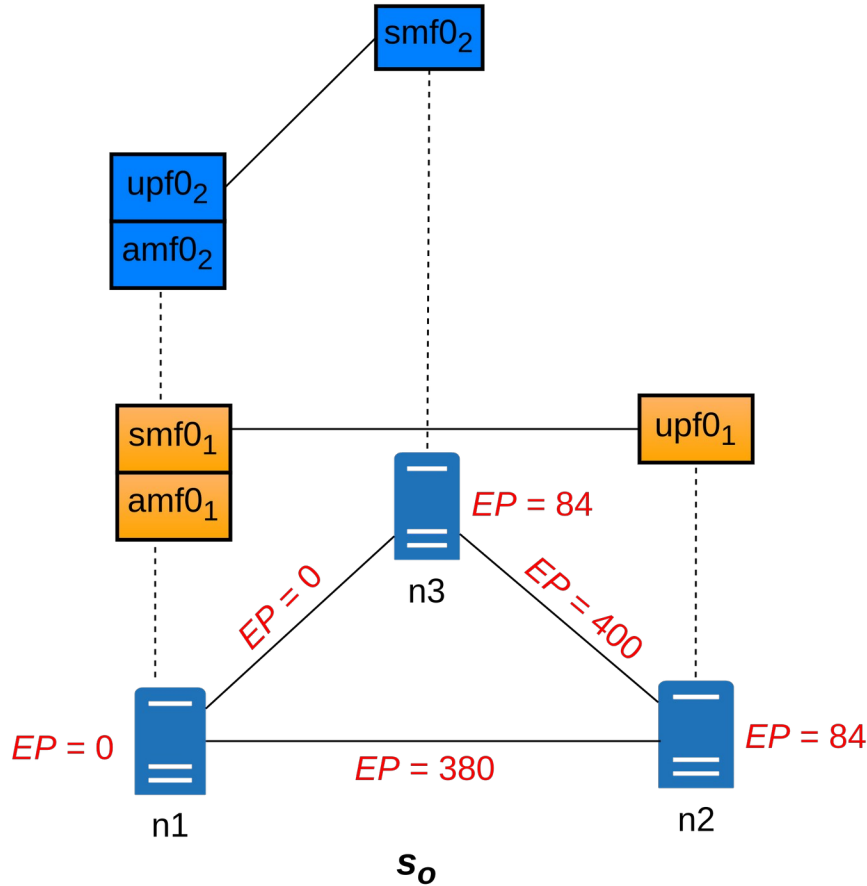

(: init

```
;SUBSTRATE NETWORK
(adjacent-nodes-i-j n1-n2 n1 n2)
(adjacent-nodes-j-i n1-n2 n2 n1)
;SLICED NETWORK
;NETWORK SLICE 1->URLLC(SERVICE FUNCTION CHAIN)
(next-vnf amf0-ns1 smf0-ns1)
(next-vnf smf0-ns1 upf0-ns1)
;vnfs mappings
(vnf-mapped-to amf0-ns1 n1)
(vnf-mapped-to smf0-ns1 n1)
(vnf-mapped-to upf0-ns1 n2)
;virtual links mappings
(v-link-mapped-to amf0-smf0-ns1 inner-path-n1)
(v-link-mapped-to smf0-upf0-ns1 n1-n2)
;SN AND SLICES ATTRIBUTES
(=(cpu-capacity n1) 112) ; 4 CPUs x 28 cores
(=(bandwidth-capacity n1-n2) 400) ; Gbps
(=(required-cpu amf0-ns1) 4.0)
(=(required-bandwidth amf0-smf0-ns1) 20);Gbps
(=(required-bandwidth amf0-smf0-ns2) 200);Gbps
(=(scaling-factor amf0-ns1) 7)
;AVAILABILITY OF RESOURCES IN SUBSTRATE NETWORK (EP)
(=(embedding-cpu n1) 0)
(=(embedding-cpu n2) 84)
(=(embedding-cpu n3) 84)
(=(embedding-bandwidth n1-n2) 380)
(=(embedding-bandwidth n1-n3) 0)
(=(embedding-bandwidth n2-n3) 400)
(=(embedding-bandwidth inner-path-n1)40000000)
(=(embedding-bandwidth inner-path-n2)40000000)
(=(embedding-bandwidth inner-path-n3)40000000)
```

)

PROPOSAL

Reconfiguration Plan

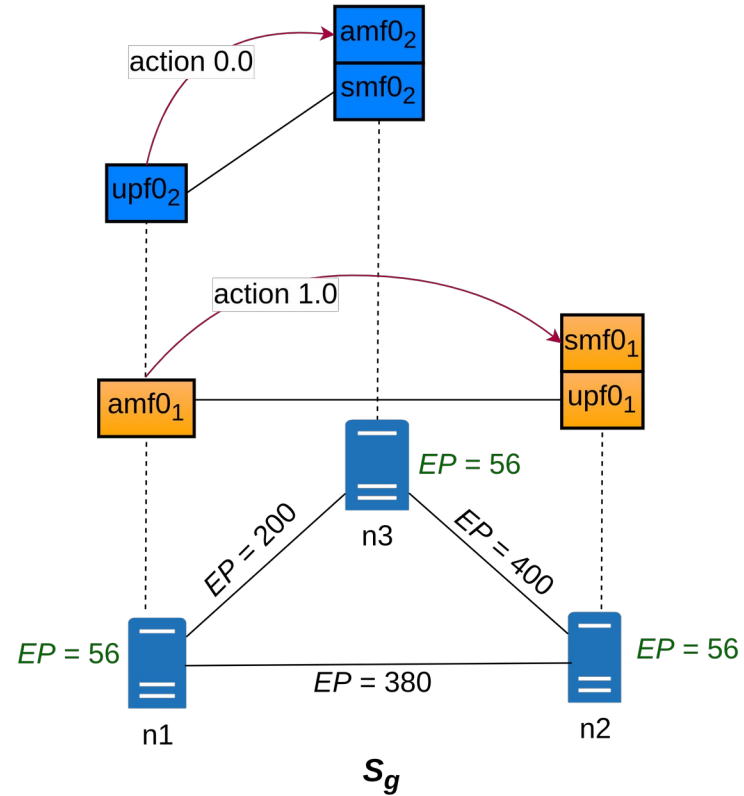
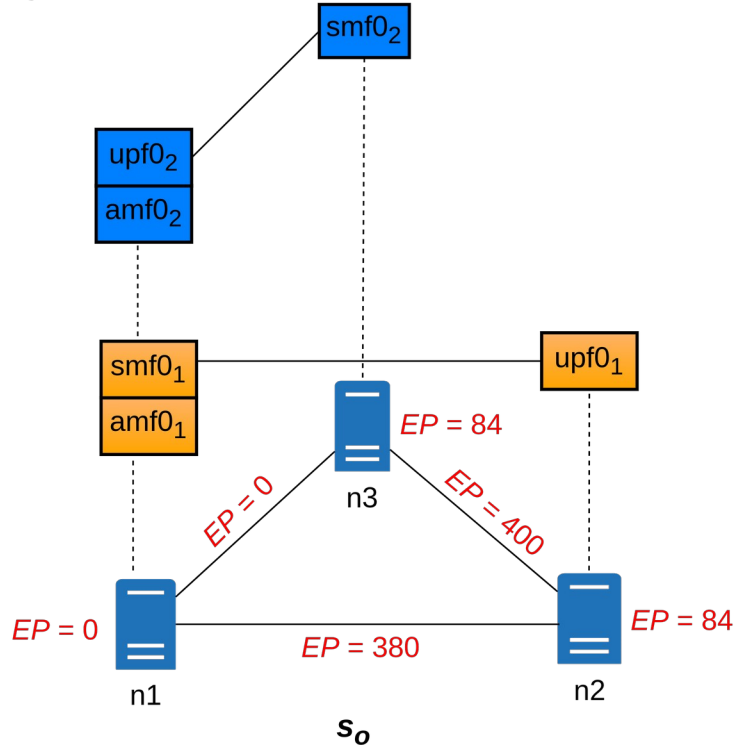

0.0: (migrate-vnf amf0-ns2 n1 n3 smf0-ns2 n3 amf0-smf0-ns2 n1-n3 inner-path-n3)

1.0: (migrate-vnf smf0-ns1 n1 n2 amf0-ns1 n1 amf0-smf0-ns1 inner-path-n1 n1-n2
upf0-ns1 n2 smf0-upf0-ns1 n1-n2 inner-path-n2)

PROPOSAL

AP-Problem instance in PDDL

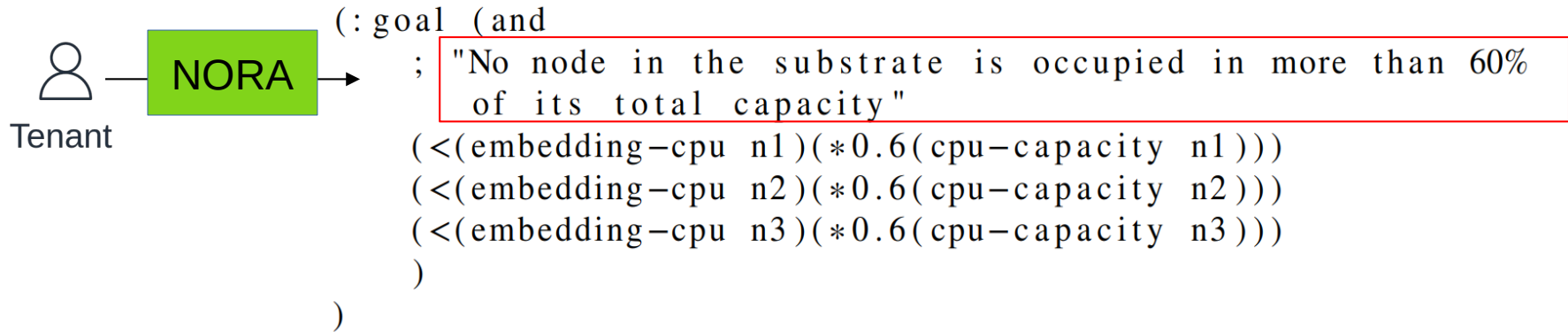

PROPOSAL Architecture

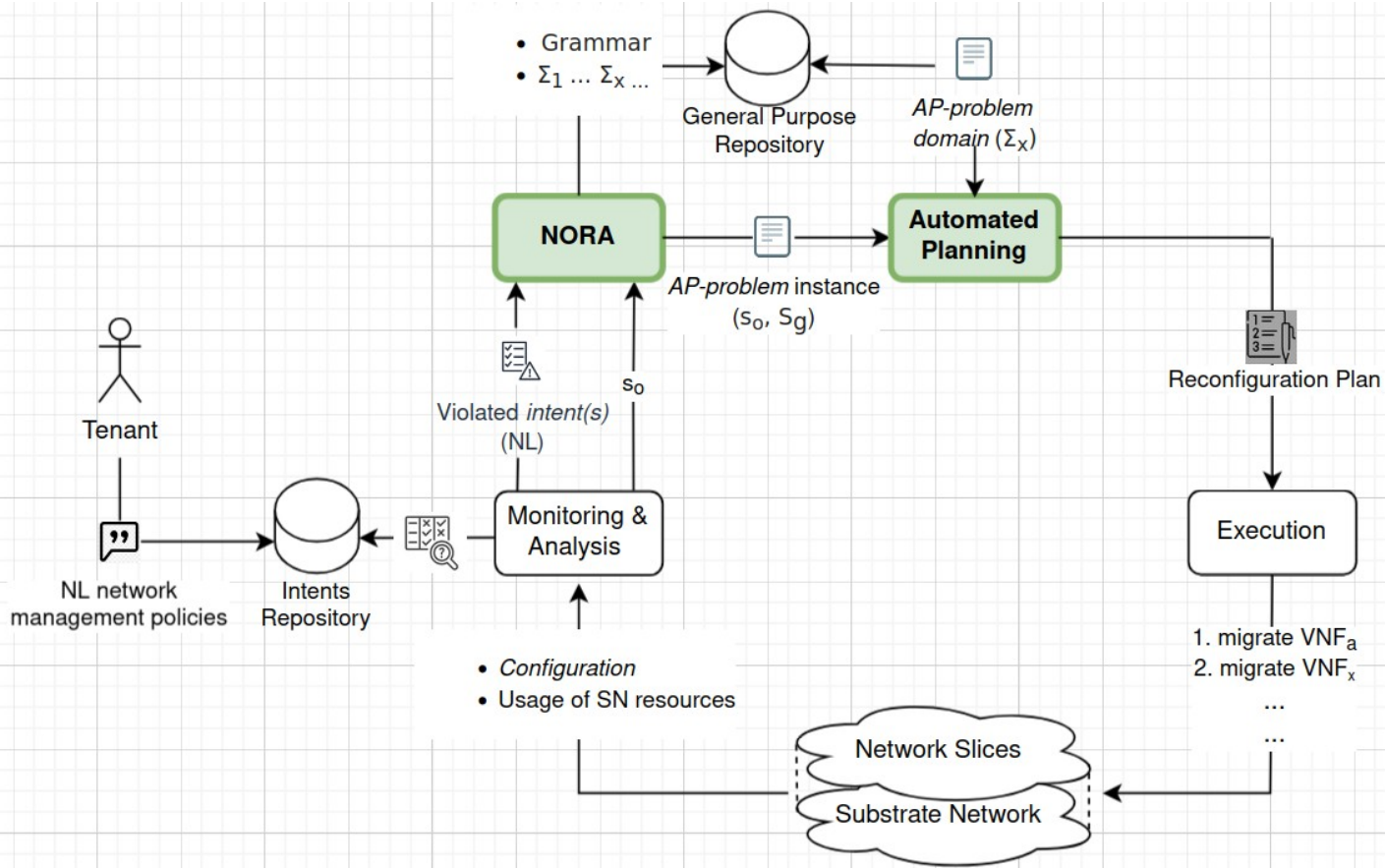

- Monitoring & Analysis observes the managed network.
- NORA transforms high-level network management policies into an AP notation.
- AP decides which of the possible VNF migrations (from Σ_x) will take place.
- Execution enforces the reconfiguration plan
- The managed network is turned from an *undesired* configuration (s_o) into a *desired* configuration (S_g)

PROPOSAL

NORA Overview

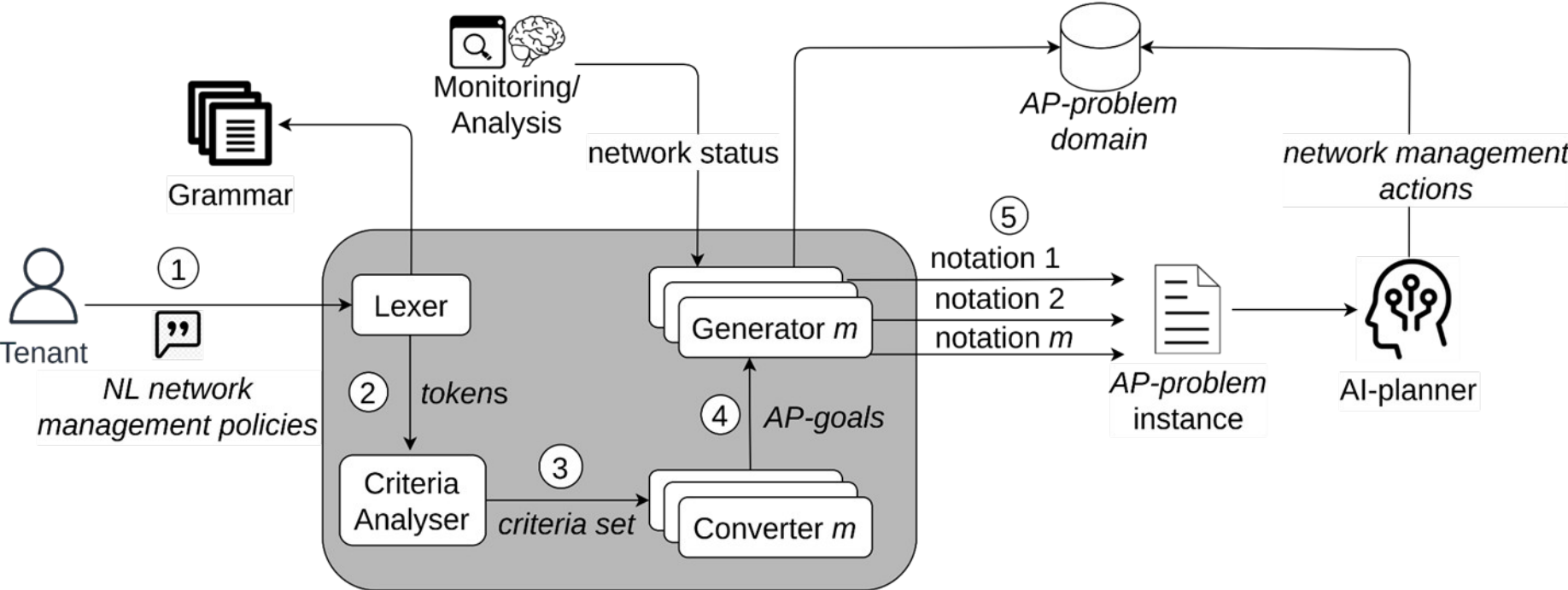

Angela Rodriguez-Vivas, Oscar Mauricio Caicedo, Armando Ordoñez, Lisandro Z. Graville and Jéferson Campos Nobre, "NORA: An Approach for Transforming Network Management Policies into Automated Planning Problems", Sensors MDPI.

PROPOSAL

NORA Grammar

Entity	Expression
Service	VoIP, Streaming, HTTP, FTP, SMTP, P2P...
Endpoint	network slice, host node, gateway, database, VM, client, user...
Metric	bandwidth, CPU, delay, packet loss, throughput, jitter, load, latency...
Condition	more, high, higher, up, over, exceed, not under,...
	equal, like, even, same, similar...
	less, lower, not exceed, down, below, under...
Threshold-unit	ms, s, kbps, GB, GHz, %...
Connection	and, also, as well as, or...

PROPOSAL

NORA Operation

"A network slice must all the time meet latency lower than 5 ms and packet loss rate under 10^{-4} "

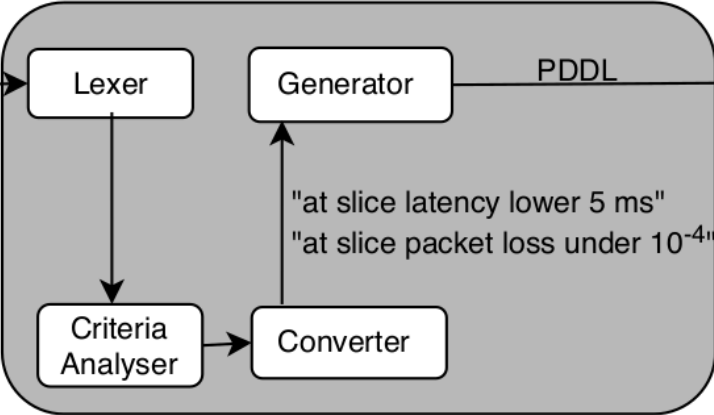

```
(define (network policy violation)
  (:domain remote surgery self-driving network)
  (:init (video streaming quality degraded))
  (:goal
    (and (at slice latency lower 5 ms)
          (at slice packet loss under 10-4))
  )))
```

EVALUATION

Test Environment: ATRAP

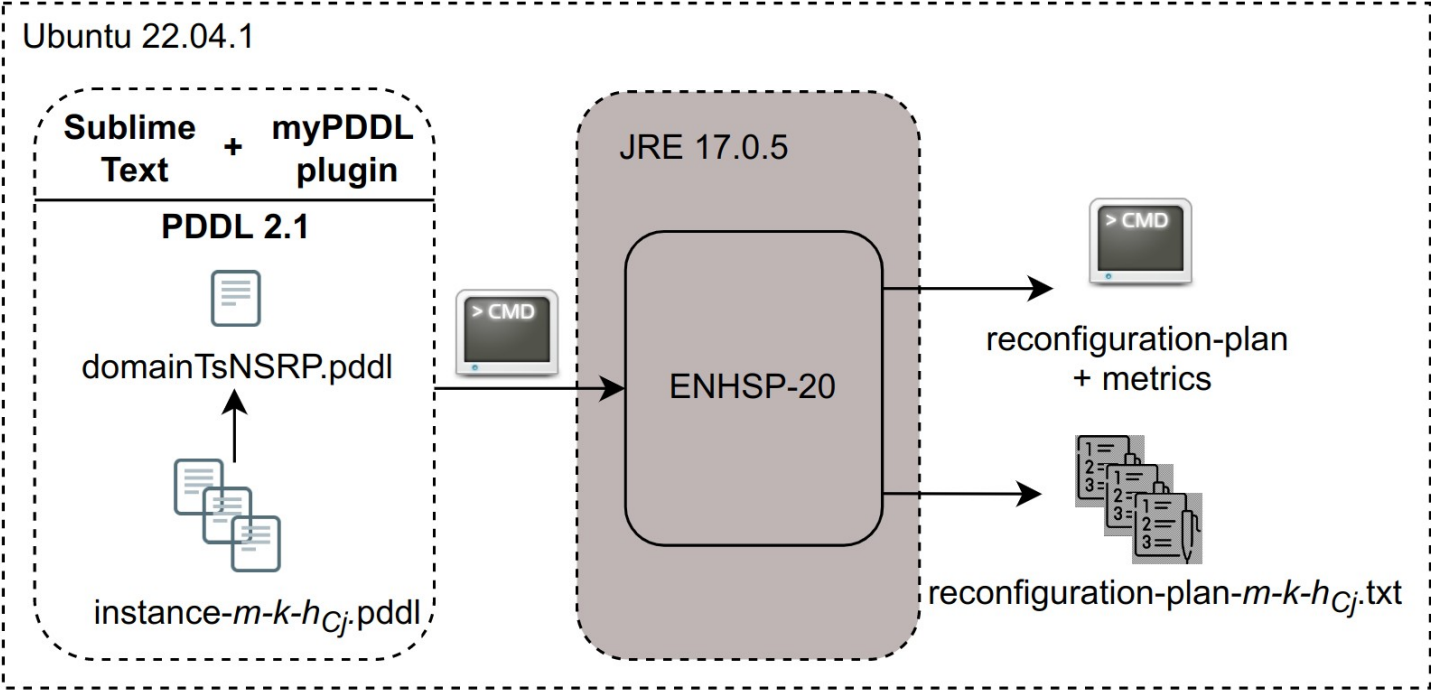

EVALUATION

ATRAP: *Plan-length*

3-node SN ($m=3$)

Network slices (k)	VNF migrations	
	Plan-length	<i>AP-problem domain actions</i> (T)
2	2	24
	1	40
4	1	48
	2	80
6	2	72
	1	120

4-node SN ($m=4$)

Network slices (k)	VNF migrations	
	Plan-length	<i>AP-problem domain actions</i> (T)
2	4	36
	4	60
4	2	72
	6	120
6	3	108
	1	180

Goal= CPU

Goal condition	VNF migrations	
	Plan-length	<i>AP-problem domain actions</i> (T)
CPU	2	72
	1	120
Bandwidth	2	72
	1	120
CPU + Bandwidth	1	72
	4	120

Goal condition	VNF migrations	
	Plan-length	<i>AP-problem domain actions</i> (T)
CPU	3	108
	1	180
Bandwidth	3	108
	4	180
CPU + Bandwidth	6	108
	10	180

$k = 6$

- 3 VNFs x network slice
- 5 VNFs x network slice

EVALUATION

ATRAP: *Planning Time*

3-node SN ($m=3$)

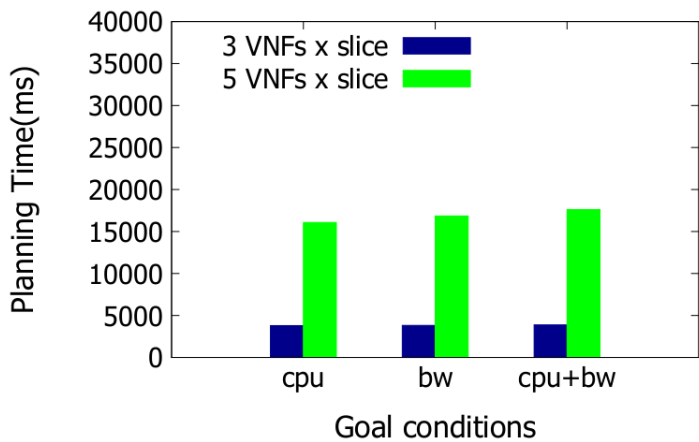
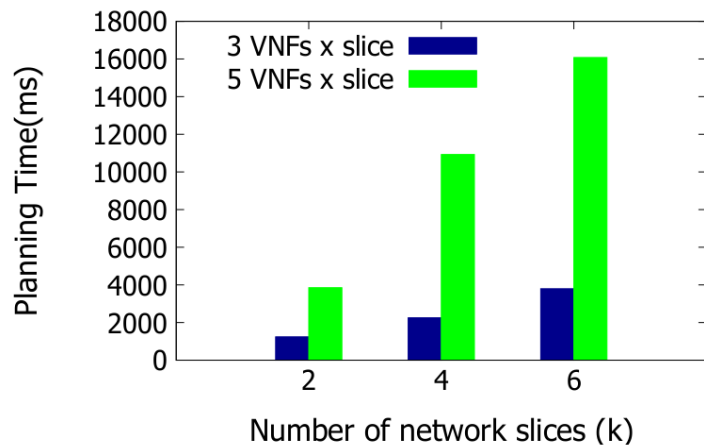

4-node SN ($m=4$)

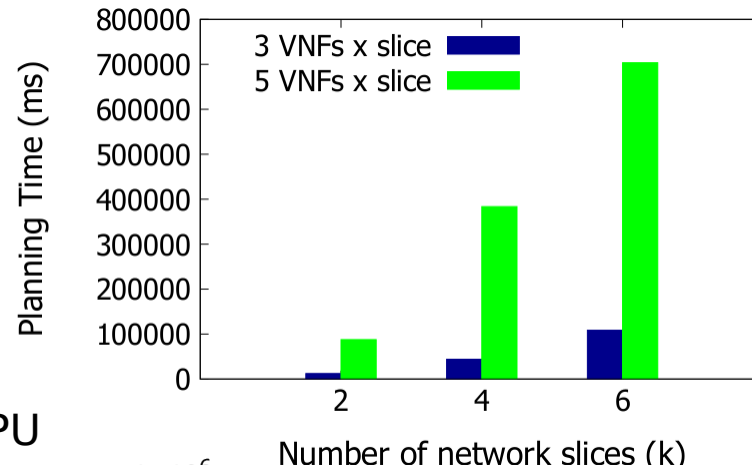

Goal= CPU

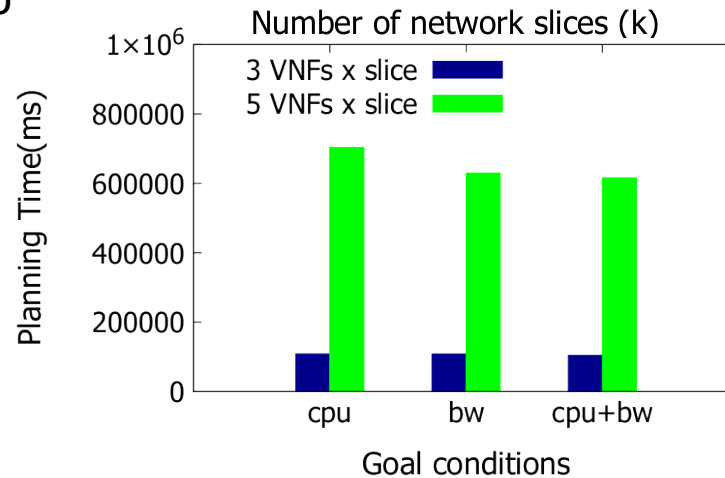

$k = 6$

EVALUATION

Test Environment: NORA

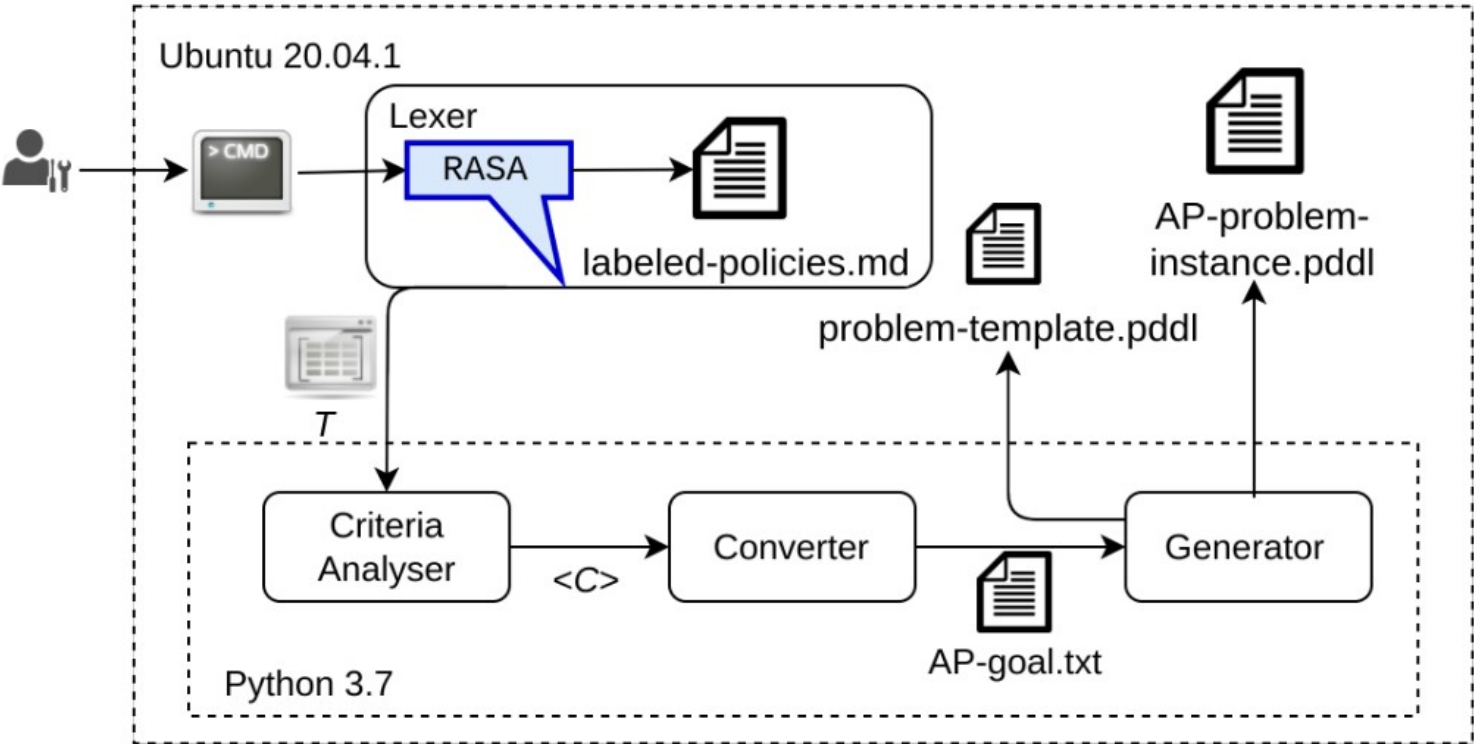

EVALUATION

NORA: *Precision and Processing Time*

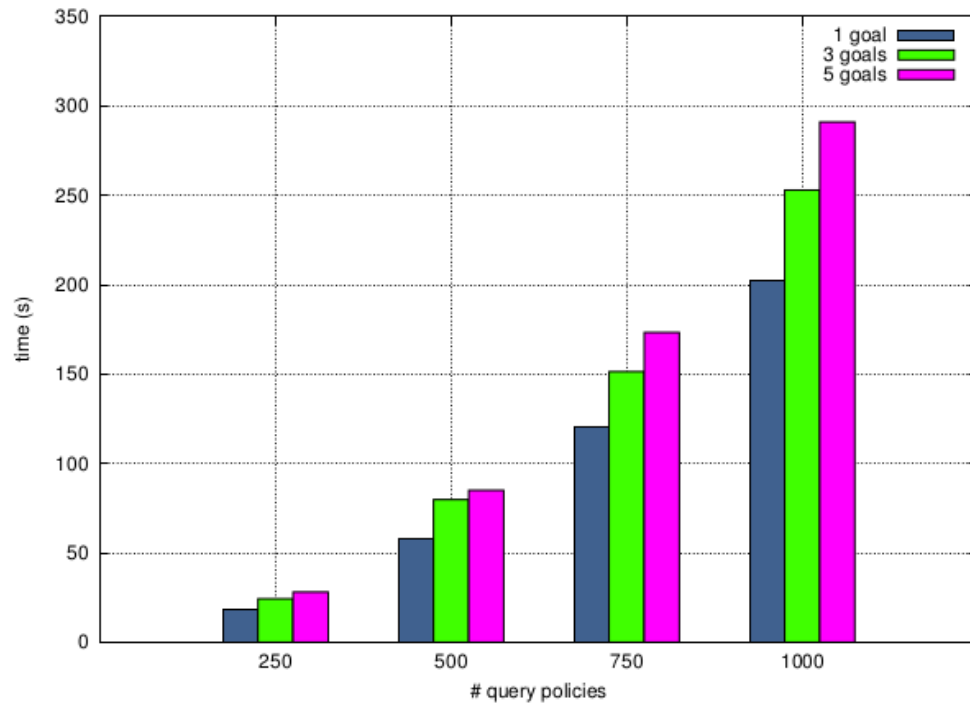
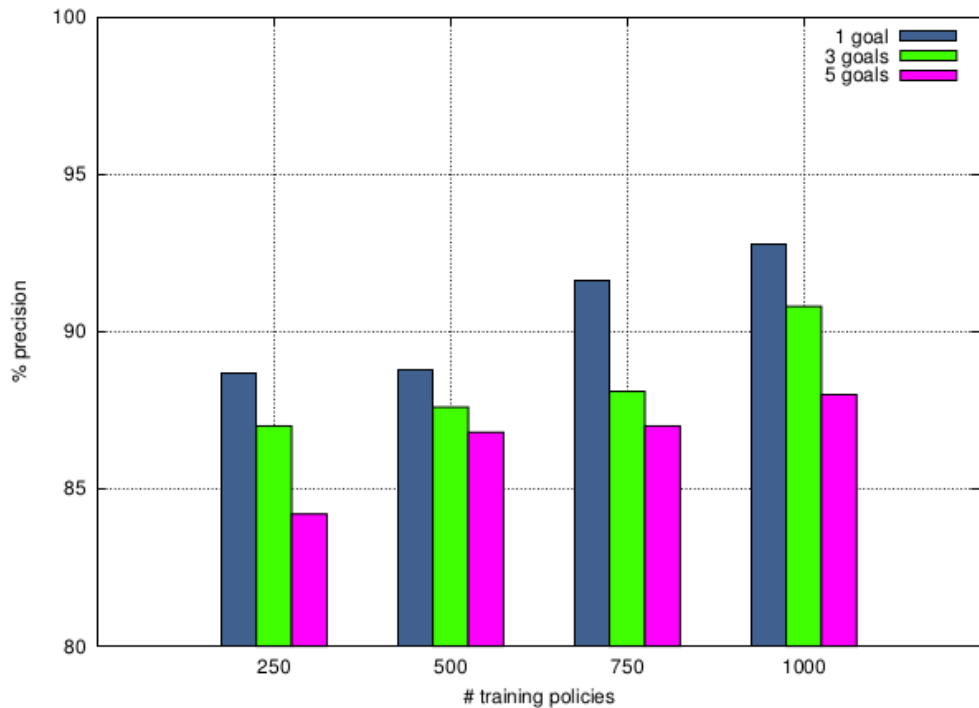

CONCLUSIONS

Given an *undesired* network configuration, how to compute reconfiguration actions (VNF migrations) on-the-fly to turn SDN into a *desired* configuration?

- AP is a feasible technique for computing network reconfiguration actions under a closed ACL.
- ATRAP effectively closes the MAPE-K based ACL coping with the main ANM goal: limit human intervention to the definition of high-level business policies.
- The road towards self-reconfigurable networks by exploiting the benefits of AP under the Autonomic Network Management paradigm is promising.

CONCLUSIONS

How to include the AP technique as decision maker in the ACL?

- MAPE-K paradigm was an adequate approach for setting up ATRAP's architecture, realizing decision-making with AP, i.e., with embedded intelligence.

CONCLUSIONS

How ACL decisions can be guided by high-level network management policies?

- AP operation is guided by the AP-goals (search in the state space), in turn represented as conditions.
- With NORA, we were able to obtain AP-goals from high-level network management policies expressed by the sliced network tenant in natural language.

REFERENCES

M. Pozza, P. K. Nicholson, D. F. Lugones, A. Rao, H. Flinck, S. Tarkoma, On reconfiguring 5g network slices, IEEE Journal on Selected Areas in Communications 38 (2020) 1542-1554.

M. Ghallab, D. Nau, P. Traverso, Automated planning and acting, Cambridge University Press, 2016.

M. Ghallab, A. Howe, C. Knoblock, D. McDermott, A. Ram, M. Veloso, D. Weld, D. Wilkins, Pddl: The planning domain definition language, version 1.2, Yale Center for Computational Vision and Control, Tech Report CVC TR98003/DCS TR1165 (1998).

Tuncer, D.; Charalambides, M.; Tangari, G.; Pavlou, G. A Northbound Interface for Software-based Networks. In Proceedings of the 2018 14th International Conference on Network and Service Management (CNSM), Rome, Italy, 5-9 November 2018; pp. 99-107.

Jacobs, A.S.; Pfitscher, R.J.; Ferreira, R.A.; Granville, L.Z. Refining Network Intents for Self-Driving Networks. In Proceedings of the Afternoon Workshop on Self-Driving Networks (SelfDN 2018), Budapest, Hungary, 24 August 2018; ACM: New York, NY, USA, 2018; pp. 15-21.

THANK YOU!

arodriguez@unicomfacauca.edu.co

<https://www.linkedin.com/in/angela-rodriguez-vivas-phd/>